

GLA-300/H

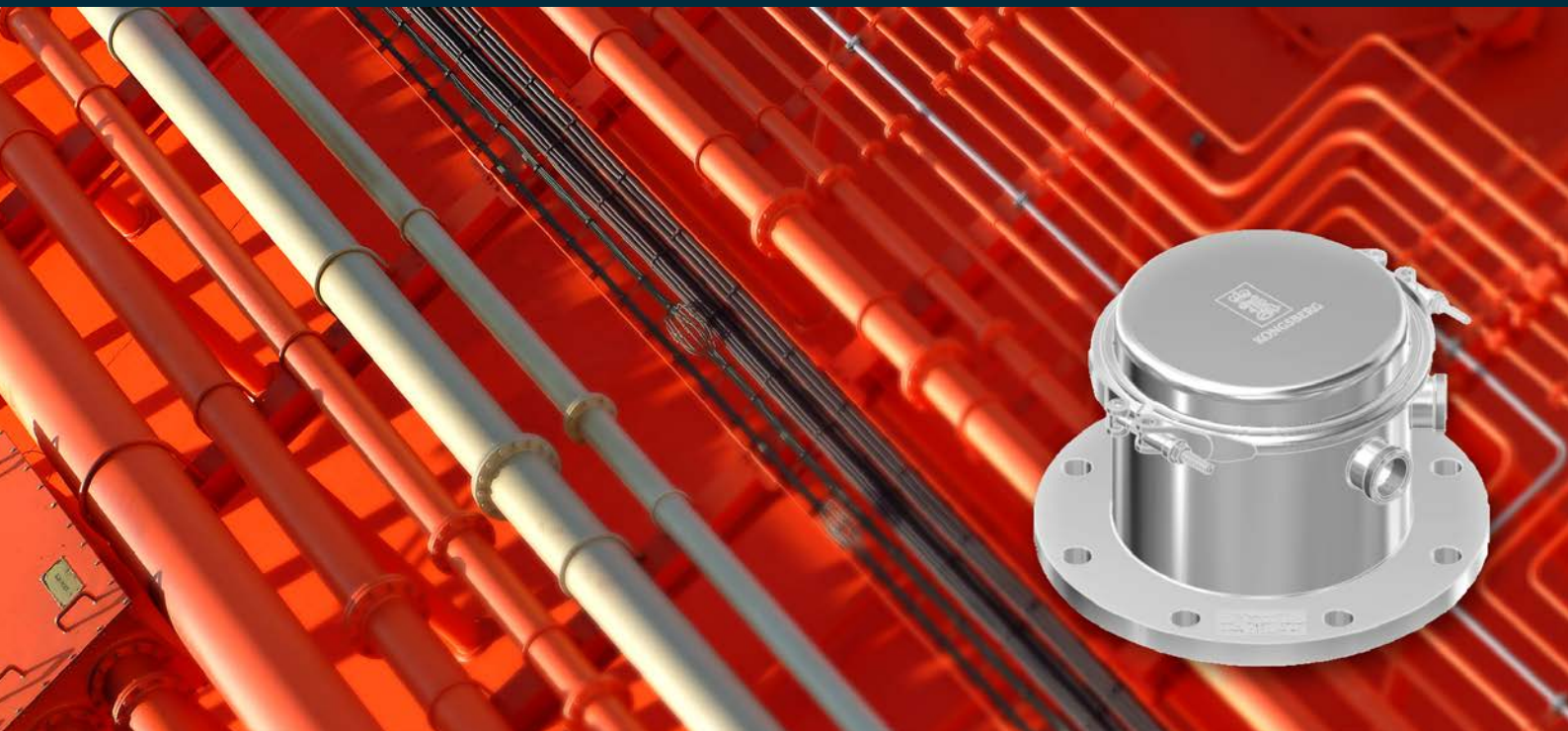

KONGSBERG



RADAR TANK GAUGE FOR CHEMICAL, ASPHALT AND BITUMEN TANKERS

The KONGSBERG GLA-300/H Radar Tank Gauge (RTG) is part of the GL-300 Tank Monitoring System. Together with the GC-300 Cargo Temperature Unit (CTU) and the GLK-300 Signal Processing Unit (SPU), the RTG introduces modern and flexible arrangements for simpler installation. The radar technology provides accurate measurement regardless of the atmospheric conditions inside the tank. The tank pressure transmitter is fully integrated by means of both mechanics, electronics and cabling.

Principle of operation

The RTG employs the Frequency Modulated Continuous Wave (FMCW) principle with dual sweep technology to eliminate Doppler-effect caused by cargo movement. The distance (i.e. ullage) is derived from the time delay of the reflected signal. The electronic unit in the RTG includes a patented signal detection method that ensures optimum performance.

A frequency sweeping microwave signal is emitted by the RTG, and by aid of the horn antenna directed vertically down the tank either directly or by an angular adapter. The high frequency combined with the antenna design gives a very narrow beam width of $\pm 4^\circ$.

The GLA-300/H is designed with a PTFE lense isolating the radar electronics from the tanks atmosphere and provide a clean surface toward the tank contents. The clean surface ensures easy cleaning of radar, which is regarded critical in the transport of hazardous chemicals.

The radar are connected to a dedicated GLK-300 SPU by a RS-485 communication link (2-pair cable).

Tank pressure transmitter

The GT450 tank pressure transmitter is fully integrated in the RTG. The transmitter comes ready installed from the factory.

The GT450 pressure transmitter is built around a dry, robust ceramic measurement capsule with internal capacitive sensing element and with a ratiometric output.

The pressure transmitter is connected to the GLK-300 SPU by a HART bus link (1-pair cable).

Tank installation

The RTG adapts to a gauge socket with a minimum inner diameter of 200 mm (larger sockets can be used if straight type). The gauge socket shall be welded to the top of the tank, preferably as close to the center of gravity of the tank as possible.

In high temperature applications, using a specially designed angular gauge socket, the radar tank gauge avoids direct heat radiation from the cargo. This reduces the exposure of the high temperature and increases the lifetime of the electronics inside the GLA-300/H housing.

The RTG housing includes a cable gland for cable connection to the GC-300 Cargo Temperature Unit (1-pair cable).

FEATURES

ORDER CODE

- Radar RMS accuracy 2 mm
- Measuring range 0 to 50 m
- Half power beam width¹ 8° (±4°)
- Operating temperature -45 to +85 °C
- Ingress protection IP 66/67
- Intrinsically safe Ex ia IIC T4 Ga
- Stainless steel AISI 316 L
- Integrated tank pressure transmitter

¹For details about free space requirements, ref. Installation Manual.

TECHNICAL SPECIFICATIONS

Radar Tank Gauge

Measuring range: 0 to 50 meter
 RMS accuracy*: 2 mm
 Frequency: K-band (24 GHz)
 Beam width: ± 4°
 Material: AISI 316L and PTFE

Tank Pressure Transmitter

Measuring range: 0.8 to 1.4 bar
 (optional 0.8 to 1.8 bar)
 Accuracy: ±1.0 % of FRO** (+20 °C to +85 °C)
 ±2.5 % of FRO** (-45 °C to +20 °C)
 Material: AISI 316 and Titanium

Common specification

Cable specification: 3 x twisted pair common screen
 Operating temperature: -45 °C to +85 °C
 Protection grade: IP66/67
 Weight: 17 kg

Ex-classification:  II 1 G Ex ia IIC T4 Ga
 Ex-certification: Sira 14ATEX2056X
 IECEx SIR 14.0025X

Environmental standards: IACS E10
 CISPR 22

Safety data

Max. input voltage: $U_i = 14,3 \text{ VDC}$
 Max. input power: $P_i = 2,1 \text{ W}$
 Max. input current: $I_i = 560 \text{ mA}$
 Max. internal capacitance: $C_i = 347 \text{ nF}$
 Max. internal inductance: $L_i = \text{negligible}$

Type approvals: ABS, BV, CCS, DNV-GL, KRS,
 LRS, NK, Rina

* RMS sensor accuracy at controlled environment

**FRO = Full Range Output

Specifications subject to change without any further notice.

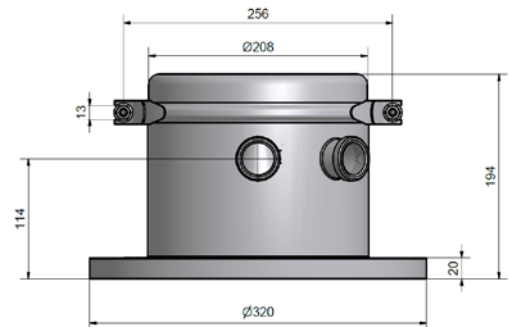
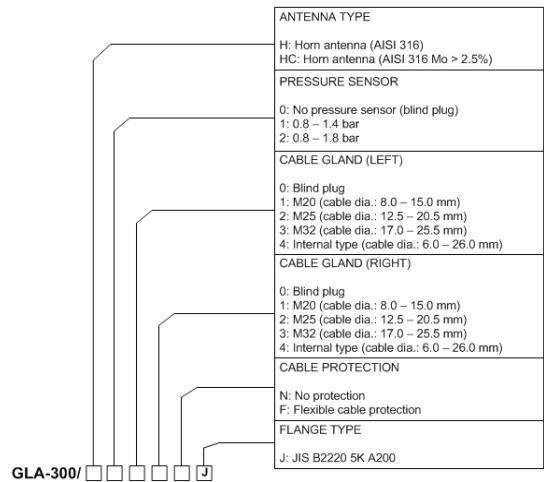

Figure 1: Dimensional drawing GLA-300/H

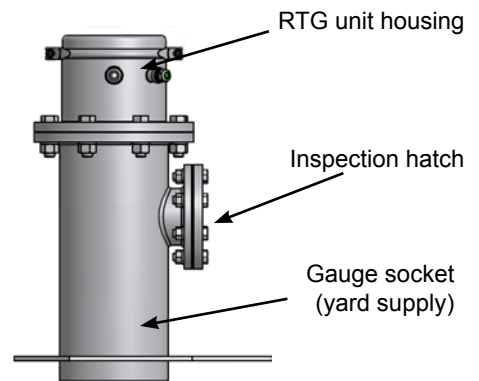

Figure 2: GLA-300/H installed on a 200 mm straight socket. Inspection hatch mounted on the gauge socket.

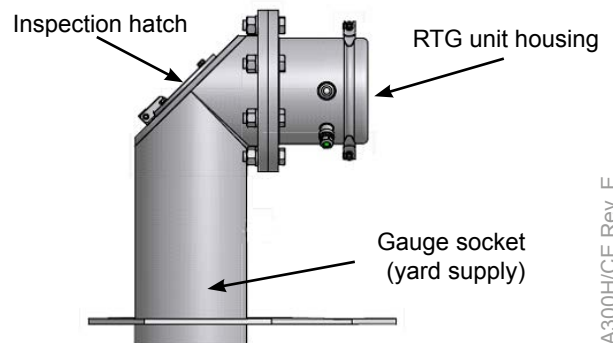

Figure 3: GLA-300/H installed on a 200 mm angular socket. Inspection hatch mounted on the gauge socket.

P-GLA300H/CE Rev. E

