

Material, sensor pipe: AISI 304
 Protection grade : IP67
 Weight (MN3294S125U15): 250 g

ORDERING EXAMPLE : MN3294 S 125U 15

Mechanical design
 Single element(Letter no. 1)
 Length of temp.sensor (L),in mm
 Element type Pt100(Letter no. 2)
 Cable length (CL) in dm

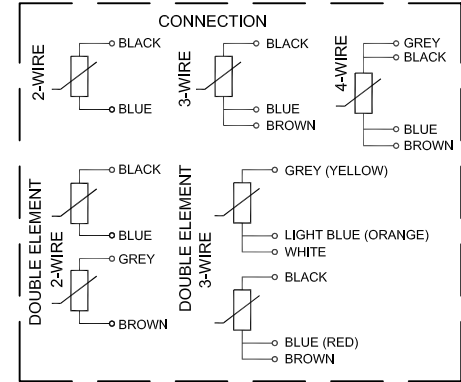

LETTER NO. 1	EXPLANATION
S	Single element, 2-wire
T	3-wire connection

LETTER NO. 2	ELEMENT TYPE	RANGE
M	Pt100ohm/0°C	-50 to 150 °C
U	Pt100 ohm/0°C	-50 to 150 °C

Date 01-11-91	Dsgn/Dwn AJK/RT	Trac	Scale/Format 1:1 [A3]
Checked	Spec Ctrf.	Approved	

Kongsberg Maritime AS
 Automation
 Trondheim

Temperature sensor type MN3294-

DIMENSIONAL SKETCH

Repl. for	Repl. by	Next sheet
Dwg no. MN-3294	Sh.no.	Rev. Lang. A