



KONGSBERG

Instruction Manual

TTC 400

Transponder Test and Configuration Unit



(Cd6925)

This manual is valid for TTC 400 v 2.0 and later.

TTC 400

Transponder Test and Configuration Unit

Instruction Manual

Note

Kongsberg Maritime AS makes every effort to ensure that the information contained within this document is correct. However, our equipment is continuously being improved and updated, so we cannot assume liability for any errors which may occur.

Warning

The equipment to which this manual applies must only be used for the purpose for which it was designed. Improper use or maintenance may cause damage to the equipment or injury to personnel. The user must be familiar with the contents of the appropriate manuals before attempting to install, operate or maintain the equipment.

Kongsberg Maritime AS disclaims any responsibility for damage or injury caused by improper installation, use or maintenance of the equipment.

Copyright

© 2004 Kongsberg Maritime AS

The information contained within this document remains the sole property of Kongsberg Maritime AS. No part of this document may be copied or reproduced in any form or by any means, and the information contained within is not to be communicated to a third party, without the prior written consent of Kongsberg Maritime AS.

Contact information

Support: ui@kongsberg.com

Sales: subsea@kongsberg.com

Kongsberg Maritime AS

Strandpromenaden 50
P.O.Box 111
N-3191 Horten,
Norway

Telephone: +47 33 02 38 00
Telefax: +47 33 04 47 53
www.kongsberg.com
E-mail: subsea@kongsberg.com



KONGSBERG

Contents

SYSTEM DESCRIPTION	1
Manual contents	1
List of abbreviations	1
TTC 400 unit	2
Transponders	3
Frequency bands	3
Channels	3
TECHNICAL SPECIFICATIONS	4
Environment	4
TTC 400 unit dimensions	4
Power supply	4
Test transducer	4
Battery specifications	4
Source level and receiver sensitivity	4
TTC 400 FRONT PANEL	5
Introduction	5
LCD display	5
Pushbuttons	5
Pushbutton functions	6
Connectors	7
OPERATION	8
Introduction	8
How to use the TTC 400 with transducer	9
Page contents	10
Active function / command	11
MENU DESCRIPTION	12
Introduction	12
Menu presentation	12
Menu overview	13
Submenus description	14
TTC parameters submenu	14
Reset to factory set	14
TTC setup	15
About	16
Transponder submenu	17
New transponder	17
Select transponder	18
Interrogate (TP / RESP. / Beacon)	19
Read battery status	20
Set parameters	21
Read parameters	22

TP function submenu	23
Scan for Ch w/Reset	23
Switch channel	24
Set TP mode	25
Reset	26
Release	27
Read TP sensor	28
Inclinometer	28
Depth & Temp	29
Compass	30
Power off	30
MAINTENANCE	31
Introduction	31
TTC 400 reset	31
Charging the battery	32
Opening the TTC 400 unit	33
Remove the rack	33
Replace the rack	33
Battery replacement	33
Replacing the circuit boards	34
General procedure	34
MAIN PARTS	35
Battery	36
General	36
Battery lifetime	36
Option	37
AC power supply	38
Description	38
Specifications	38
AC power supply connector	39
Front panel unit	40
Front panel connectors	40
Flylead connectors	41
Transmitter board (Tx)	45
Receiver board (Rx)	47
Microcontroller board	49
Switches	49
Battery charger board (Charger-2)	51

- Charger 51
- Display Power 52
- Power control 52
- Responder Trig 52
- Motherboard 54
 - Description 54
 - Connectors 55
 - Fuses 55
 - Switches 55
- SPARE PARTS 56**
 - Introduction 56
 - TTC 400 unit 56
 - Complete unit 56
 - Main modules 56
 - Options 56
- HELP FUNCTION 57**
 - TTC 400 help 57
- INDEX 58**

Document logistics

Rev	Date	Written by	Checked by	Approved by
A	22.04.03	GM	SER	JEF
B	08.10.03	GM	SER	JEF
C	07.01.04	GM	JO	JEF
D	23.06.04	GM	JO	JEF

(The original signatures are recorded in the company's logistic database)

Rev	Comments
A	Original issue.
B	Company information updated. Minor corrections in the text. Updated spare parts. EM 857-164788B.
C	Updated according to software update. Minor corrections in the text. Updated spare parts. EM 857-164788C.
D	Implemented new battery. Minor corrections in the text. EM 857-164788D.

SYSTEM DESCRIPTION

Manual contents

This is the Instruction manual for the TTC 400, Transponder Test and Configuration Unit.

It provides unit description, technical specifications, operating instructions and maintenance procedures.

List of abbreviations

HiPAP	High Precision Acoustic Positioning
HPR	Hydroacoustic Position Reference
LCD	Liquid Crystal Display
LF	Low frequency
MF	Medium frequency
MPT	Multifunction Positioning Transponder
MST	Mini SSBL Transponder
PCB	Printed Circuit Board
RSP	Responder
RPT	ROV Positioning Transponder
Rx	Receive
SPT	SSBL Positioning Transponder
TD	Transducer
TEL	Telemetry
TP	Transponder
Tx	Transmit

TTC 400 unit

The TTC 400 contains all necessary functions for testing and configuration of a transducer, both on deck and at sea.

The TTC 400 is based around a splash-proof, small «all in one» and portable unit with carrying-handles and internal battery supply.

The transducer with cable connects to the front of the unit, and this is all what is required to perform a test / configuring of a transducer.



Figure 2 TTC 400 unit and test and configuration transducer

Transponders

- The TTC 400 is to be used for test and configuration of the Kongsberg Maritime Multifunction Positioning Transponder (MPT) and SSBL Positioning Transponder (SPT) transponders.
- An overview of available transponders, refer to the respective transponder Instruction manual.

Note

The ROV Positioning Transponder (RPT) and the Mini SSBL Transponders (MST), can be checked by INTERROGATE the TP channel. No other function or command can be used against the RPT / MST because these transponders have no telemetry interface.

Frequency bands

The TTC 400 can test and configure transponders using the 30 kHz frequency band (MF).

Channels

The TTC 400 applies for:

- The 56 (B12 - B87) High Precision Acoustic Positioning (HiPAP) channels.
- The 56 (B12 - B87) Hydroacoustic Position Reference (HPR 400) channels.
- The Hydroacoustic Position Reference (HPR 300) channels. These are: (B01 - B09), B11, B22, B33, B44 and B55.

TECHNICAL SPECIFICATIONS

Environment

Operation temperature	0 to +55°C
Splash proof	IP64

TTC 400 unit dimensions

Material	Aluminium
Height x width x depth	173 x 297 x 250 mm
Depth including handles	290 mm
Weight	6.8 kg

Power supply

Internal rechargeable battery	Lead / Acid
External	100-240 Vac

Test transducer

Height / Diameter	80 mm / 55 mm
Weight in air	0.7 kg
Cable length	2.5 m

Battery specifications

 Refer to page 36

Source level and receiver sensitivity

Model series	Source level - max (4 steps of 3 dB)	Receiver sensitivity HIGH / LOW (2 steps)
TTC 400 test and configuration TD	175	125 / 135

TTC 400 FRONT PANEL

Introduction

The TTC 400 front panel includes:

- LCD display
- Pushbuttons
- Connectors for external connections



Figure 3 TTC 400 unit front panel

LCD display

The LCD display is used for menu presentation, selection and activation of menu functions. The window presentation exists of 13 lines, each with maximum 30 characters.

☞ *Menu and menu operation, refer to page 12.*

Pushbuttons

The unit has pushbuttons for selecting and entering commands from a displayed menu.

Pushbutton functions

↑	<ul style="list-style-type: none"> • Move the cursor upwards in the menu • Increase the required selection <ul style="list-style-type: none"> - Press the button: one step at a time - Press and hold the button: fast count • SELECT the required menu input
↓	<ul style="list-style-type: none"> • Move the cursor downwards in the menu • Reduce the required selection <ul style="list-style-type: none"> - Press the button: one step at a time - Press and hold the button: fast count • SELECT the required menu input
→	<ul style="list-style-type: none"> • Select the Main Menu states • Move the cursor to the right • ENTER, next menu level appear
←	<ul style="list-style-type: none"> • CLOSE, go back one menu level • Returns the control to previous state level
POWER	Switch ON the system (TTC 400) NOTE: To switch OFF the system you must use the menu function POWER OFF. If POWER OFF is not activated, the system will be switched off automatically after 10 minutes.
LIGHT	Background light, toggle ON/OFF. The background light will automatically switch OFF after 1 minute if no operation. Press LIGHT to toggle the light ON.
HELP	Short information on how to use the TTC 400.

☞ Refer to page 57.

Example:

By pressing the up/down arrow the operator selects the main menu, and then pressing the right arrow the TTC 400 will ENTER the main menu's submenu.

A second level menu will appear on the display and the TTC 400 operator can SELECT the submenu. When pressing the LEFT button the TTC 400 will CLOSE or "Abort" the prepared command.

Connectors

The following connections are implemented:

- TD - Transducer for transponder test and configuration
- AC IN:
 - TTC 400 power (100 -240) Vac
 - Ac power for battery charging
- RSP - for responder cable (responder trigger signal) for responder function test.

OPERATION

Introduction

The TTC 400 is normally used for test and configuration of a transponder on deck.

Note

The TTC 400 can also be used while connected to the mains.

Optionally the TTC 400 may be used for:

- Responder function
 - TTC 400 can be used to test responders, the dedicated responder cable must be used.
- Dunking transducer
 - TTC 400 can be used together with a Kongsberg Maritime dunking transducer for test and operation at sea.

The optional cable and dunking transducer w/cable are not a part of the standard TTC 400 delivery. These items must be ordered separately. Order number for available transponder cables:

☞ *Refer to page 56.*

☞ *For dunking transducers, refer to the HPR 400 portable system documentation.*

How to use the TTC 400 with transducer

- 1 Connect the transducer cable to the TTC 400 unit.
 *Connector, refer to the figure on page 2.*
- 2 Place the transducer face to face with the transponder transducer, as illustrated on the figure below.

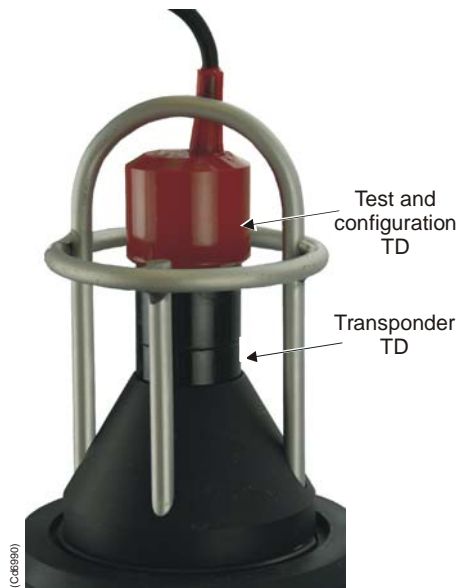

Figure 4 Transponder top with test and configuration transducer

WARNING

Due to safety rules, the transponder must be handle with care. Refer to:

- **Safety information for transponder and transponder battery chapter in the respective transponder manual.**

- 3 Press the **POWER** button on the front panel.
 - The MAIN MENU page is displayed.
 - Only three menu selections will be presented in LCD window at the same time.

- 4 Select the required menu. The selection is displayed in inverse video.

 *Pushbutton functions, refer to page 6.*

Note

The unit will automatically power off after 10 minutes.

```

TTC 400 MF                               Bat% 100
-----
TRANSPONDER
TP FUNCTION                               <status field>
READ TP SENSOR

TP SNo:  2000  Ch:  B12  Org:  B12
          TTC          TP    v65
Tx Power:  HIGH          HIGH
Rx Gain :  HIGH          HIGH

CLOSE ←          SELECT ↑↓          ENTER →

```

Page contents

- Bat%** = Indicates *remaining battery capacity* for the TTC 400 unit 100-0 %
- SNo** = Serial number -
the default serial number is 2000
- Ch** = Channel -
the default frequency channel is B12.
☞ *Channels available, refer to page 3.*
- Org** = Original channel, ref channel
- TP** = Transponder
- TTC** = The TTC 400 unit
- vXX** = Transponder software version
- Tx Power** = Transmit power
- Rx Gain** = Receive gain

Acoustic status field

The acoustic status field will be used for presentation of information during and after an acoustic operation.

Status Field	=	State of status
ACK OK	=	Acknowledge / Ok
NO ACK	=	No Acknowledge / No replay
XX	=	“Count down ” while waiting for transponder reply.

Active function / command

In this manual, some of the selections (inverse video) are shown in bold text.

The following applies when a function / command is executed:

- The system counts down **XX** in the status field, while waiting for reply.
- When the reply from the transponder / responder is received, **ACK OK** is written in the status field.
- If there is no reply from the transponder / responder, **NO ACK** will be written in the status field.

The TTC 400 menu operation is described on the following pages.

MENU DESCRIPTION

Introduction

This section provides a detailed description of the complete menu system for the TTC 400.

The menu system has two levels:

- 1 Top level (Main menu) - this will appear when the system is switched ON.
- 2 Level of commands (submenu), for operator selection.

Menu presentation

Note

Only three menu lines are presented in the window at a time! This applies for both the main menu and the submenus. The selected command is always presented at the same menu line (the middle line) as indicated below. The example presents main menu selections, but only part of the window is shown.

```

TTC 400 MF                               Bat% 100
-----
TTC PARAMETERS
TRANSPONDER
TP FUNCTION
  
```

If the top main menu / submenu command is selected, the top line is blank.

```

TTC 400 MF                               Bat% 100
-----
TTC PARAMETERS
TRANSPONDER
  
```

If the last main menu / submenu command is selected, the bottom line is blank.

```

TTC 400 MF                               Bat% 100
-----
READ TP SENSOR
TPOWER OFF
  
```

Menu overview

The menu system includes the following:

(Each menu / submenu is described on the page indicated below.)

MAIN MENU	SUB MENU
TTC PARAMETERS This menu includes reset / setup and information about of the TTC 400	<ul style="list-style-type: none"> • RESET TO FACTORY SET, <i>page 14</i> • TTC SETUP, <i>page 15</i> • ABOUT, <i>page 16</i>
TRANSPONDER This menu includes various TP functions.	<ul style="list-style-type: none"> • NEW TRANSPONDER, <i>page 17</i> • SELECT TRANSPONDER, <i>page 18</i> • INTERROGATE (TP / Responder / Beacon), <i>page 19</i> • READ BATTERY STATUS, <i>page 20</i> • SET PARAMETERS, <i>page 21</i> • READ PARAMETERS, <i>page 22</i>
TP FUNCTION This menu includes transponder commands.	<ul style="list-style-type: none"> • SCAN FOR CH. W/ RESET, <i>page 23</i> • SWITCH CHANNEL, <i>page 24</i> • SET TP MODE (Enable SSBL TP / Disable TP / Enable Responder / Enable Beacon), <i>page 25</i> • RESET (<i>Normal / Factory</i>), <i>page 26</i> • RELEASE, <i>page 27</i>
READ TP SENSOR This menu includes reading of various sensors.	<ul style="list-style-type: none"> • INCLINOMETER (Internal / External / Differential), <i>page 28</i> • DEPTH AND TEMP, <i>page 29</i> • COMPASS, <i>page 30</i>
POWER OFF Switch off the TTC 400.	<ul style="list-style-type: none"> • <i>No submenu, refer to page 30</i>

Submenus description

This chapter describes all the submenus and commands accessed from the TTC 400 Main menu.

TTC parameters submenu

The TTC PARAMETERS is the menu for setup of the TTC 400 operator unit, and it also contains the "ABOUT" which includes the TTC 400 software version.

Reset to factory set

This command makes a complete reset of the TTC 400. All entered parameters will be deleted, and the TTC 400 will be set up to the initial mode.

TTC PARAMETERS	Bat% 100

RESET TO FACTORY SET	XX
PRESS: ENTER → FOR 3 SEC	
TP SNo: 2000	Ch: B12 Org: B12
	TTC TP
Tx Power:	HIGH HIGH
Rx Gain :	HIGH HIGH
CLOSE ←	SELECT ↑↓ ENTER →

TTC setup

This command enables you to set the TTC 400 **Tx power** and **Rx gain**. The available parameters are:

Tx Power	Rx Gain
- MAX	- HIGH
- HIGH	- LOW
- LOW	
- MIN	

- 1 Select **TTC 400 SETUP** and press **ENTER** →.
 - The system moves to the Tx Power input field.
- 2 Select the required Tx power and press **ENTER** →.
 - The system moves to the Rx Gain input field.
- 3 Select the required Rx gain and press **ENTER** →.

☞ *Function / command activated, refer to page 11.*

TTC PARAMETERS		Bat% 100

TTC SETUP		XX
TP SNo: 2000	Ch: B12	Org: B12
	TTC	TP
Tx Power:	HIGH	HIGH
Rx Gain :	HIGH	HIGH
CLOSE ←	SELECT ↑↓	ENTER →

About

```
TTC PARAMETERS                               Bat% 100
-----
ABOUT
TTC 400  11. 12. 03 v2.0

TP SNo: 2000    Ch: B12    Org: B12
              TTC          TP
Tx Power:    HIGH        HIGH
Rx Gain :    HIGH        HIGH

CLOSE ←      SELECT ↑↓    ENTER →
```

Transponder submenu

When the operation has been performed, the system will return to the transponder menu page with submenu. This only applies for the Transponder menu.

New transponder

Before any command can be given to the transponder, the **serial number** and **channel** must be selected.

Note

If the transponder you are going to test / configure has been configured in the system (used before), you can use the "Select transponder" command. You just select the transponder from a list.

This command enables you to set the transponder serial number and channel.

 *Default settings, refer to page 10.*

- 1** Select **NEW TRANSPONDER** and press **ENTER →**.
 - The system moves to the serial number input field.
- 2** Select the required serial number **TP SNo <xxxx>** and press **ENTER →**.
 - The system moves to the channel input field.
- 3** Select the required channel **Ch B: <xx>** and press **ENTER →**.
 - The **Org** (original channel) will be updated accordingly.

 *Function / command activated, refer to page 11.*

TRANSPONDER	Bat% 100

NEW TRANSPONDER	
TP SNo: 2000	Ch: B12 Org: B12
	TTC TP
Tx Power: HIGH	HIGH
Rx Gain : HIGH	HIGH
CLOSE ←	SELECT ↑↓ ENTER →

Select transponder

From this page you can select one of the 20 latest used transponders.

Note

The last used or selected transponder will be shown.

- 1 Select **SELECT TRANSPONDER** and press **ENTER** →.
 - The system moves to the serial number input field.
- 2 Select the required transponder serial number **TP SNo** <xxxx> from the list and press **ENTER** →.
 - The channel and original channel for the selected transponder is displayed.

☞ *Function / command activated, refer to page 11.*

TRANSPONDER	Bat% 100

SELECT TRANSPONDER	
TP SNo: 2000 Ch: B12 Org: B12	
	TTC TP
Tx Power:	HIGH HIGH
Rx Gain :	HIGH HIGH
CLOSE ←	SELECT ↑↓ ENTER →

The selected transponder is now active.

Interrogate (TP / RESP. / Beacon)

When you activate this command, the TTC 400 will start interrogating (testing) the TP. The range to the transponder will be measured and calculated based on the default parameters. The following are available:

- TP (Transponder)
- BEACON
- RESP. (Responder)

- 1 Select the type to be interrogated and press **ENTER** →.
 - The transponder test interrogation rate is 2 seconds for TP. The replay timeout is set to 4 seconds and the sound velocity is set to 1500 m/s.

 *Function / command activated, refer to page 11.*

The replay will be REPLAY OK / NO REPLAY accordingly.

TRANSPONDER	Bat% 100						
INTERROGATE	TP xx						
Range: xxxx.xx m	REPLAY OK						
TP SNo: 2000 Ch: B12 Org: B12							
	<table style="width: 100%; border: none;"> <tr> <td style="width: 50%; text-align: center;">TTC</td> <td style="width: 50%; text-align: center;">TP</td> </tr> <tr> <td style="text-align: center;">Tx Power: HIGH</td> <td style="text-align: center;">HIGH</td> </tr> <tr> <td style="text-align: center;">Rx Gain : HIGH</td> <td style="text-align: center;">HIGH</td> </tr> </table>	TTC	TP	Tx Power: HIGH	HIGH	Rx Gain : HIGH	HIGH
TTC	TP						
Tx Power: HIGH	HIGH						
Rx Gain : HIGH	HIGH						
CLOSE ←	SELECT ↑↓	ENTER →					

xxxx.xx = Range in meters

Read battery status

When you activate this command, the *remaining battery capacity* for the selected transponder will be calculated.

Note

The selected transponder has to be a MPT or a SPT type.

The selections on the TTC 400 are:

- 316 - 163
- 331 - 139 / 339
- 319/L - 319 / 314 / 313

☞ *For description of the transponders, refer to the respective transponder Instruction manual.*

1 Select the required transponder model and press **ENTER** →.

☞ *Function / command activated, refer to page 11.*

2 When executed, the following page is displayed.

READ BATTERY STATUS		Bat% 100

TP Model:	331	
Used in %	Rx: 0	Tx: 0
TP SNo: 2000	Ch: B12	Org: B12
	TTC	TP
Tx Power:	HIGH	HIGH
Rx Gain :	HIGH	HIGH
CLOSE ←	SELECT ↑↓	ENTER →

Set parameters

This command enables you to set the transponder **TX power** and **RX gain**. The available parameters are:

Tx Power	Rx Gain
- MAX	- HIGH
- HIGH	- LOW
- LOW	- MIN
- MIN	

- 1 Select **TRANSPONDER SETUP** and press **ENTER** →.
 - The system moves to the Tx Power input field.
- 2 Select the required Rx power and press **ENTER** →.
 - The system moves to the Rx Gain input field.
- 3 Select the required Rx gain and press **ENTER** →.

☞ *Function / command activated, refer to page 11.*

TRANSPONDER	Bat% 100

SET PARAMETERS	XX
TP SNo: 2000	Ch: B12 Org: B12
	TTC TP
Tx Power: HIGH	HIGH
Rx Gain : HIGH	HIGH
CLOSE ←	SELECT ↑↓
	ENTER →

Read parameters

When you activate this command, a short status from the specified transponder will be performed.

- 1 Select **READ PARAMETERS** and press **ENTER** →.
 - If the reading is **OK**, the status included the transponder software version is presented as shown below.

 *Function / command activated, refer to page 11.*

- 2 When executed, the following page is displayed.

READ PARAMETERS	Bat% 100

Mode: TP ENABLE	
LIC Ch:	TAD: 60 ms
Beam: N/W	Pulse L: 10 ms
TP SNo: 2000	Ch: B12 Org: B12
	TTC TP v65
Tx Power:	HIGH HIGH
Rx Gain :	HIGH HIGH
CLOSE ←	SELECT ↑↓
	ENTER →

LIC Ch = Long Baseline interrogation Channel

TAD = Turn Around Delay (ms)

Beam = Selections:
 N = Narrow
 W = Wide

Pulse L = Pulse length (ms)

vxx = Transponder software version

 *Tx Power / Rx Gain refer to page 21.*

TP function submenu

Scan for Ch w/Reset

This command can be used if you know the transponder serial number., but have lost the track of the transponder channel.

- 1 Select, and the scan test starts automatically.
- 2 The TTC 400 starts to interrogate each HiPAP / HPR 400 channel, and then the HPR 300 channels one time.
- 3 A RESET (NORMAL) is sent to the transponder (by using the selected transponder's Serial No. for example 2000), and if it matches:
 - the TTC 400 will update the channel no. and write the TP program version (example: v6.5).
- 4 If No replay is received, repeat the command.

 *Function / command activated, refer to page 11.*

TP FUNCTION	Bat% 100

SCAN FOR Ch. W/RESET	xx
TP SNo: 2000	Ch: B12 Org: B12
	TTC TP v65
Tx Power: HIGH	HIGH
Rx Gain : HIGH	HIGH
CLOSE ←	SELECT ↑↓ ENTER →

Switch channel

This command enables you to switch the transponder channel.

☞ *Default settings, refer to page 10.*

- 1 Select **SWITCH CHANNEL** and press **ENTER →**.
 - The system moves to the channel number input field.
- 2 Select the required channel and press **ENTER →**.
 - The TTC 400 will transmit the new channel number to the transponder, and the transponder will automatically switch to the new channel.

☞ *Function / command activated, refer to page 11.*

TP FUNCTION	Bat% 100

SWITCh ChANNEL	xx
TP SNo: 2000	Ch: B12 Org: B12
	TTC TP v65
Tx Power: HIGH	HIGH
Rx Gain : HIGH	HIGH
CLOSE ←	SELECT ↑↓ ENTER →

Set TP mode

This command enables you to set the transponder mode. The following modes are available:

- **ENABLE SSBL TP** - sets the transponder into SSBL navigation mode.
- **ENABLE BEACON** - sets the transponder into beacon mode.
- **ENABLE RESP.** (responder) - change the transponder to initial setting.
- **DISABLE** - sets the transponder into disable mode. This means that the transponder will not be active and only respond to the Enable function.

This command sets the transponder into required navigation mode.

- 1 Select the required mode and press **ENTER** →.
 - The TTC 400 will transmit the new channel number to the transponder, and the transponder will automatically switch to the selected mode.

 *Function / command activated, refer to page 11.*

TP FUNCTION	Bat% 100

SET TP MODE <selected mode>	XX
TP SNo: 2000	Ch: B12 Org: B12
	TTC TP v65
Tx Power: HIGH	HIGH
Rx Gain : HIGH	HIGH
CLOSE ←	SELECT ↑↓ ENTER →

Reset

This command has the following options:

- **NORMAL** - This command will **RESET** the transponder to initial channel and power settings, and the reply show the channel and the software version of the transponder.
- **FACTORY** - This command will **RESET** clear up all the transponder memory, including the battery status.

1 Select the required reset function and press **ENTER** →.

☞ *Function / command activated, refer to page 11.*

TP FUNCTION	Bat% 100	

RESET	NORMAL	
PRESS: ENTER → FOR 3 SEC		
TP SNo: 2000	Ch: B12	Org: B12
	TTC	TP v65
Tx Power:	HIGH	HIGH
Rx Gain :	HIGH	HIGH
CLOSE ←	SELECT ↑↓	ENTER →

Release

This command will activate the transponder release mechanism.

1 Select **RELEASE** and press **ENTER →**.

 *Function / command activated, refer to page 11.*

TP FUNCTION	Bat% 100

RELEASE	
PRESS: ENTER → FOR 3 SEC	
TP SNo: 2000	Ch: B12 Org: B12
	TTC TP v65
Tx Power: HIGH	HIGH
Rx Gain : HIGH	HIGH
CLOSE ←	SELECT ↑↓ ENTER →

Read TP sensor

Inclinometer

This command select type of transponder inclinometer. The following inclinometers are available:

- INTERNAL
- EXTERNAL
- DIFF (Differential)

1 Select the inclinometer type to be Interrogated and press **ENTER** →.

 *Function / command activated, refer to page 11.*

2 When executed, the following page is displayed.

```

READ TP SENSOR                               Bat% 100
-----
INCLINOMETER  INTERNAL

  Incl X: xx.x  Incl Y: yy.y

TP SNo: 2000      Ch: B12   Org: B12
                TTC        TP   v65
Tx Power:   HIGH      HIGH
Rx Gain :   HIGH      HIGH

CLOSE ←          SELECT ↑↓          ENTER →
  
```

xx.x = Inclinometer x-axis, ± degrees
(example 15.6 °)

yy.y = Inclinometer y-axis, ± degrees
(example 5.6 °)

Depth & Temp

This command will read the pressure and temperature from the selected transponder.

1 Select and press **ENTER** →.

☞ *Function / command activated, refer to page 11.*

2 When executed, the following page is displayed.

READ TP SENSOR	Bat% 100

DEPTH & TEMP	
Press: ppp.p	Bar dddd.d m
Temp : tt.t	Deg C
TP SNo: 2000	Ch: B12 Org: B12
	TTC TP
Tx Power: HIGH	HIGH
Rx Gain : HIGH	HIGH
CLOSE ←	SELECT ↑↓ ENTER →

ppp.p = Pressure in bar

ddd.d = Depth in meter

ttt.t = Temperature in degrees C

Compass

This command will read the compass sensor status from the selected transponder.

- 1 Select **COMPASS** and press **ENTER** →.
- 2 The reply from the transponder is presented as **HEADING / INCL**.
 - If there is no reply from the transponder, **NO ACK** will be written in the status field.
- 3 When executed, the following page is displayed.

```

READ TP SENSOR                               Bat% 100
-----
COMPASS
    Heading:  hhh.h
    Incl X:xx.x  Incl Y:yy.y

TP SNo: 2000      Ch: B12   Org: B12
                TTC           TP
Tx Power:   HIGH      HIGH
Rx Gain :   HIGH      HIGH

CLOSE ←          SELECT ↑↓          ENTER →
  
```

hhh.h = 0.0 - 360.0 °

xx.x = Inclinator x-axis, ± degrees
(example 15.6 °)

yy.y = Inclinator y-axis, ± degrees
(example 5.6 °)

Power off

This menu has no submenu.

When activated, the TTC 400 is switched off.

- 1 Select and press **ENTER** →.
 - If **POWER OFF** is not used, the TTC 400 will be switched off automatically after 10 minutes!

MAINTENANCE

Introduction

The maintenance consists primarily of charging the battery when the system is not in use. To change a circuit board or the battery, the unit must be opened.

TTC 400 reset

The reset command makes a complete reset of the TTC 400. All entered parameters will be deleted, and the TTC 400 will be set up to the initial mode.

A reset of TTC 400 can be done by:

- **Master Reset** - press the **LIGHT** button and the arrow **UP** simultaneously for more than 5 sec.

or

- **Using the Menu** - activate the **RESET TO FACTORY SET** command in the TTC PARAMETERS menu.

Caution

After new software installation, the master reset must always be executed.

Charging the battery

The TTC 400 is designed to remain on charge at all times while not in use.

To start the charging:

Note

Use only the mains cable supplied with the system.

- 1 Connect the cable to the AC IN connector on the front of the TTC 400 unit.



Figure 5 Mains cable

- 2 Connect the other end of the cable into a 230 Vac mains supply.
 - The green LED above the AC IN connector will change colour from yellow to green when the battery capacity is higher than 90 percent of full capacity.

If the battery is completely discharged, a complete recharge will take approx. 14 hours.

If the TTC 400 is stored away, it is important that the battery is fully charged. It must be recharged at least every 12 months.

Opening the TTC 400 unit

To gain access to the circuit boards, the electronic rack must first be removed from the housing.

Remove the rack

- 1 Place the TTC 400 unit on a stable work bench.
- 2 Remove the twelve hex screws using a 2.5 mm socket screw driver, and lift up the clamp ring and the gasket.

 Refer to figure on page 2.

- 3 Place the unit on the work bench.
- 4 Gently pull up the rack and place it on the work bench.
- 5 Remove the back cover of the rack (6 screws).

The circuit boards can now be removed from the rack.

Replace the rack

- 1 To replace the rack into the housing, follow the procedure above in reverse order.
- 2 Place the housing on the floor or on the work bench with the opening upwards, and support it so it cannot fall over.

Note

It is a support-pin on the right hand side at the rear of the housing. Ensure that it is entering the hole at the rear of the rack when the rack is gently lowered down into the housing.

- 3 Replace the gasket, clamp ring and the twelve screws.

Battery replacement

The battery is not a field replaceable part.

Replacing the circuit boards

General procedure

To remove one of the circuit boards, proceed as follows:

- 1 Remove the rack unit from the housing.

☞ *Refer to page 33.*

Note

*Remember to set the On/Off switch to **Off** before removing the battery.*

☞ *On /off switch, refer to the figure on page 35.*

- The circuit boards are now accessible.

- 2 If the faulty board is connected to another board (CPU / Receiver), remove the cable from the faulty board.

To replace a board, proceed as follows:

- 1 Find the appropriate slot for the board, and locate the board carefully into the rails.
- 2 Slide the board into the rack till the edge connector on the back of the board begins to mate with the connector on the backplane.
- 3 Replace the cable connector as appropriate.
- 4 Replace the back cover of the rack (6 screws).
- 5 Replace the rack unit into the housing.

☞ *Refer to page 33.*

MAIN PARTS

The TTC 400 rack is constructed of extruded aluminium strips and plates. It contains the following units and boards:

Units

- Battery
- Power supply
- Front Panel Unit

Circuit boards

- Transmitter board (Tx)
- Receiver board (Rx)
- Microcontroller board
- Battery charger board (Charger-2)
- Motherboard

The placement of the units and boards are shown in the figure below.

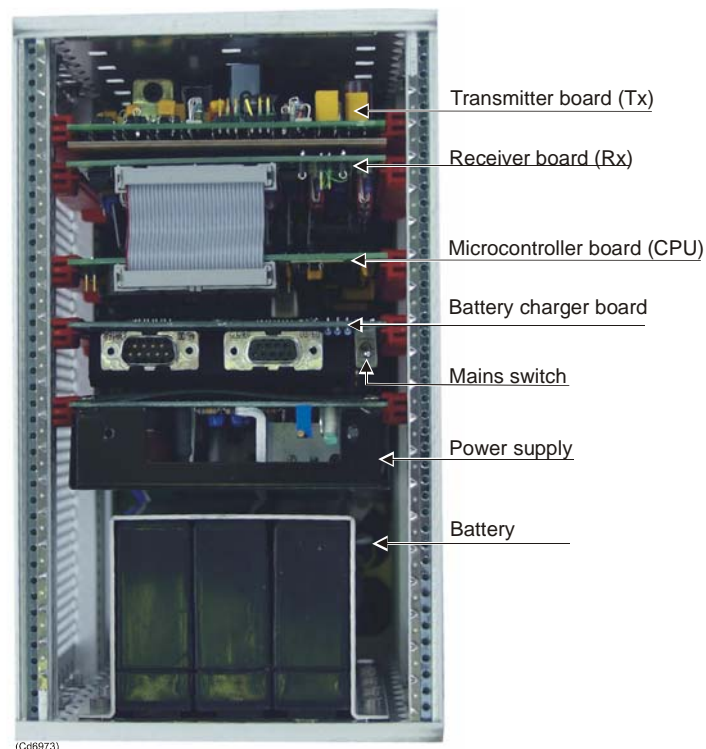

Figure 6 TTC 400 - internal layout

Battery

General

The battery is a rechargeable Lead / Acid battery. It is mounted at the right side of the rack.

Battery lifetime

The battery may be stored for up to two years (if fully charged), though it will require charging before use.

- A fully charged battery will last for approximately 5 hours operation.
- A discharged battery will require approximately 14 hours charging to be fully charged.

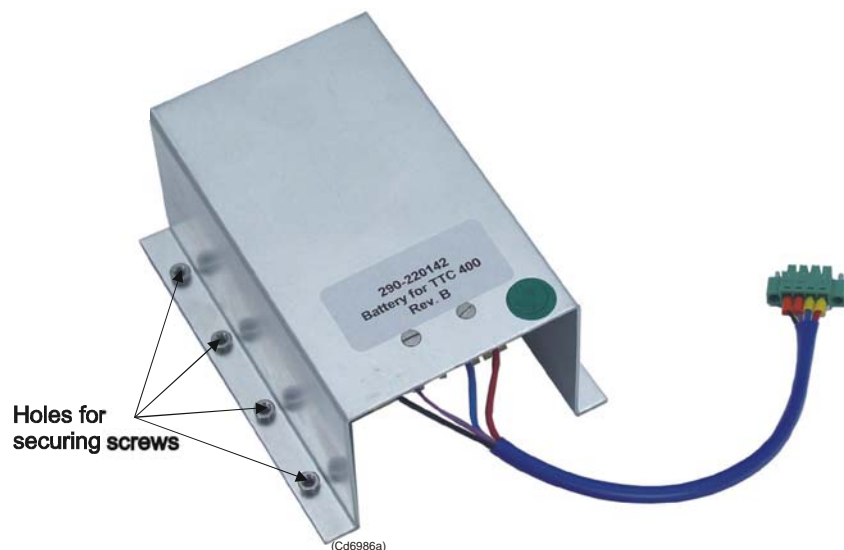

Figure 7 TTC 400 internal battery

Battery plug (P7)

4 pin Phoenix_3.81 plug		
<i>Pin</i>	<i>Signal</i>	<i>Description</i>
1	+36 V	+36 V battery output
2	0 V	0 V (GND)
3	Sense_1	Temperature sense (+)
4	Sense_2	Temperature sense (-)

The battery includes:

- Eighteen (18) rechargeable sealed lead/acid cells of 0.7 Ah
These cells are connected in one serial string, giving an operation voltage of 35 to 40 volt.
- A silicone fuse of 1.6 amps to prevent fire hazards.
- A temperature transducer that will generate a current output of 1 μ A per Kelvin. This is used by the battery charger board (Charger-2) to interrupt the charging due to high temperature.
- A cable that leads from the battery to the battery connector (P7) on the left side to the Motherboard.

Option

- The Microcontroller board can monitor the temperature inside the battery.

AC power supply

Description

The AC power is a 45 watts single Euro-size switching power supply. It is connected to the Motherboard via a 15 pin (DIN 41612) connector.

This power supply is a sealed unit. In the event of malfunction, replace the unit.



Figure 8 AC power supply

Specifications

Input voltage	100 - 240 Vac
Input frequency	47 - 63 Hz
Inrush current	25 - 30 A / 230 Vac
Output voltage	48 Vdc
Switching frequency	45 kHz

AC power supply connector

15 pin power plug		
<i>Pin</i>	<i>Signal</i>	<i>Description</i>
Z4	+48 V	+48 Vdc output
D6	+48 V	+48 Vdc output
Z8	+sense	Pos. voltage feedback signal
D10	-sense	Neg. voltage feedback signal
Z12	0 V	0 V (GND)
D14	0 V	0 V (GND)
Z28	230 Vac	230 Vac Line
D30	230 Vac	230 Vac Neutral
Z32	GND	GND

Front panel unit

The Front panel unit holds:

- A front plate containing all function switches and indicator LEDs.
 - All switches are membrane-type switches, which will ensure reliable functionality in all type of weather. All connectors used are equipped with protection caps which will prohibit water ingression.
- A LCD display with an integrated display driver / controller.
 - The display unit is a 240 x 128 dots transfective LCD graphic display with a LED04 back-light and a Toshiba T6963C controller.
- Panel connectors for ac power input, transducer signals and responder trig signals.
- Connectors for Motherboard interconnection.

Front panel connectors

 *Front panel unit - front side, refer to page 5*

AC IN - is the ac power connector (RECEPT 62GB-57A-08-4P)

Pin/	Signal
a	L
b	AGND
c	N
d	(not connected)

TD - is the transducer connector (RECEPT 62GB-57A-08-3S)

Pin	Signal
a	Signal
b	Signal (return)
c	Screen

RSP - is the transducer connector (D-SUB 9p, IP67 w/filter)

Pin	Signal
2	RS-232 Rx (optional)
3	RS-232 Tx (optional)
5	GND (common)
9	RES_TRIG signal

Flylead connectors

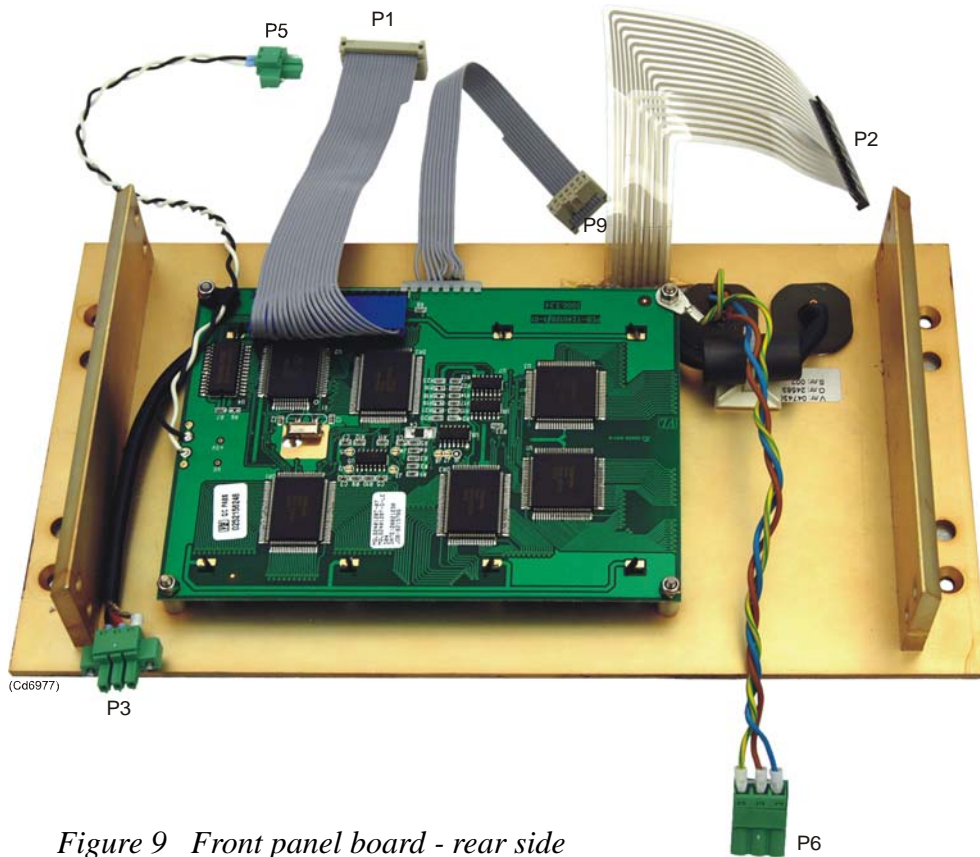

Figure 9 Front panel board - rear side

Display back-light plug (P5)

2 pin Phoenix_3.81 plug		
<i>Pin</i>	<i>Signal</i>	<i>Description</i>
1	BL+	Led Back Light power (+3.5 Vdc)
2	BL-	Led Back Light power (0 V)

LCD display plug (P1)

20 pin 3M female plug		
<i>Pin</i>	<i>Signal</i>	<i>Description</i>
1	FG	Frame Ground
2	VSS	System ground (GND)
3	VDD	Power supply for logic (+5 V)
4	Vo	Power supply for LDC (-15 V)
5	/WR	Data write
6	/RD	Data read
7	/CE	Chip enable
8	C/D	Command read/write
9	/RST	Reset
10	DB0	Data input / output (LSB)
11	DB1	
12	DB2	
13	DB3	
14	DB4	
15	DB5	
16	DB5	
17	DB7	Data input / output (MSB)
18	FS	Font select
19		
20		

Front panel plug (P2)

16 pin Single-In-Line female plug		
<i>Pin</i>	<i>Signal</i>	<i>Description</i>
1	LIFHT_IN	Signal from LIGHT switch
2	HELP	Signal from HELP switch
3	PWRSW_RET	Signal from POWER switch
4	PWRSW	Signal from POWER switch
5	EXE_LEFT	Signal from LEFT EXECUTE switch
6	EXE_RIGHT	Signal from RIGHT EXECUTE switch
7	UP	Signal from UP ARROW switch
8	RIGHT	Signal from RIGHT ARROW switch
9	LEFT	Signal from LEFT ARROW switch
10	DOWN	Signal from DOWN ARROW switch
11	VCC	System logic voltage (+5 V)
12	LED_PWR	+5 Vdc supply to charger
13	LED_GN	Charger indicator Standby LED (green)
14	LED_YE	Charger indicator Charging LED (yellow)
15	TX_LED	Transmit pulse indicator LED (yellow)
16	PWR_VCC	Power for TX_LED

Transducer plug (P3)

3 pin Phoenix_3.81 plug		
<i>Pin</i>	<i>Signal</i>	<i>Description</i>
1	TD	Transducer signal from the TX_pcb
2	TD_RET	Transducer signal from the TX_pcb
3	GND	System ground

220 Vac power plug (P6)

3 pin Phoenix_5.04 plug		
<i>Pin</i>	<i>Signal</i>	<i>Description</i>
1	230 Vac	230 Vac line
2	230 Vac	230 Vac line
3	AGND2	Protective ground (chassis)

Responder trig plug (P9)

10 pin 3M female plug		
<i>Pin</i>	<i>Signal</i>	<i>Description</i>
1	232_RX	RS-232 receive line
2	232_TX	RS-232 transmit line
3		
4		
5	GND	System ground
6		
7		
8		
9	R_TRIG	Responder trigger signal (+10 V)
10		

Transmitter board (Tx)

The Transmitter board is a general purpose transmitter, containing its own frequency generator, power control and power supply circuits, (the board feeds both the receiver and microcontroller circuit boards).

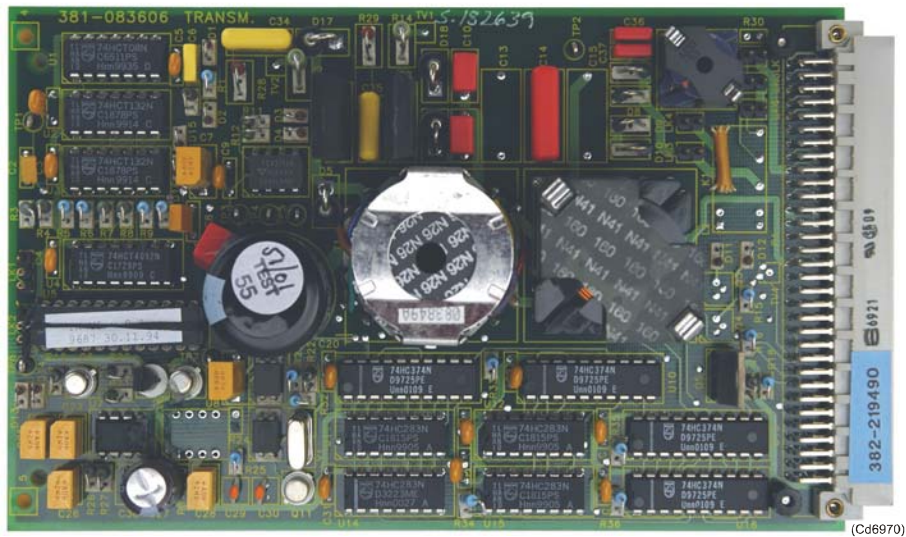

Figure 10 Transmitter circuit board

☞ Refer to figure on page 46 for the block diagram.

The board holds two voltage regulators which output the voltages required by the other boards. It also has a crystal oscillator which is used as the Tx frequency source, and a direct numerical synthesizer for generating the correct Tx frequency. Driver stages with power control, an output stage with over-current protection, and transducer matching circuits, complete the board.

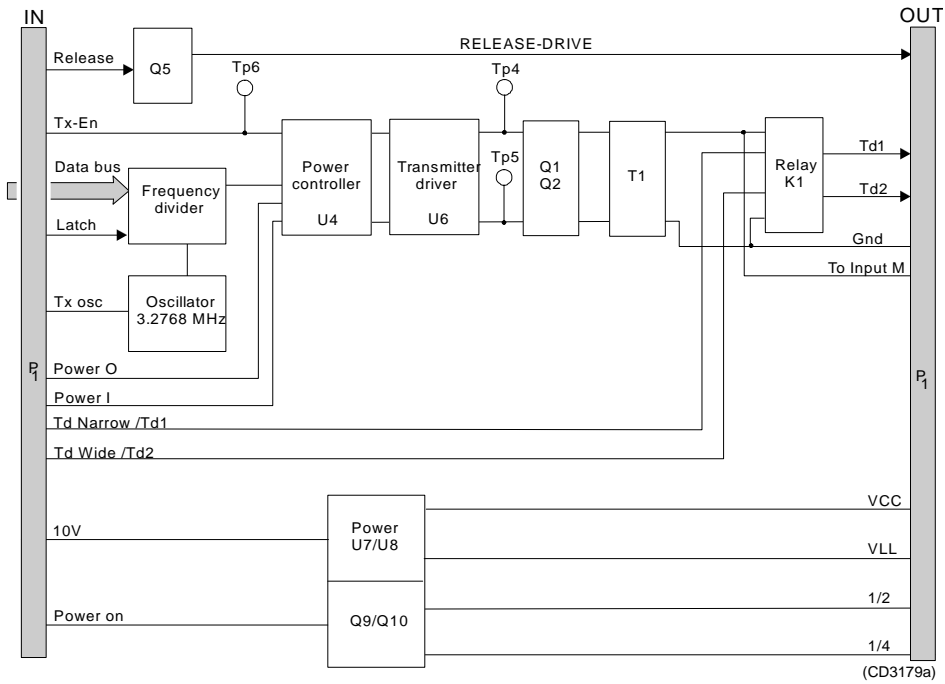

Figure 11 Transmitter circuit board - block diagram

Receiver board (Rx)

The receiver board is designed to receive transponder interrogation signals and telemetry signals. It contains nine narrow-band channel receivers, and a WIDE-detector and phase-locked loops for generating the right modulation frequencies to the channel receivers.



Figure 12 Receiver circuit board

☞ Refer to figure on page 48 for the block diagram.

The board consists of a two stage amplifier with signal limitation and an anti-aliasing filter, two channel receiver stages for wake-up, and seven channel receiver stages for telemetry, all constructed as ceramic hybrid circuits. The channel receivers perform mixing, low-pass filtering, summing and envelope detection. The outputs from the channel receivers are fed to the microcontroller.

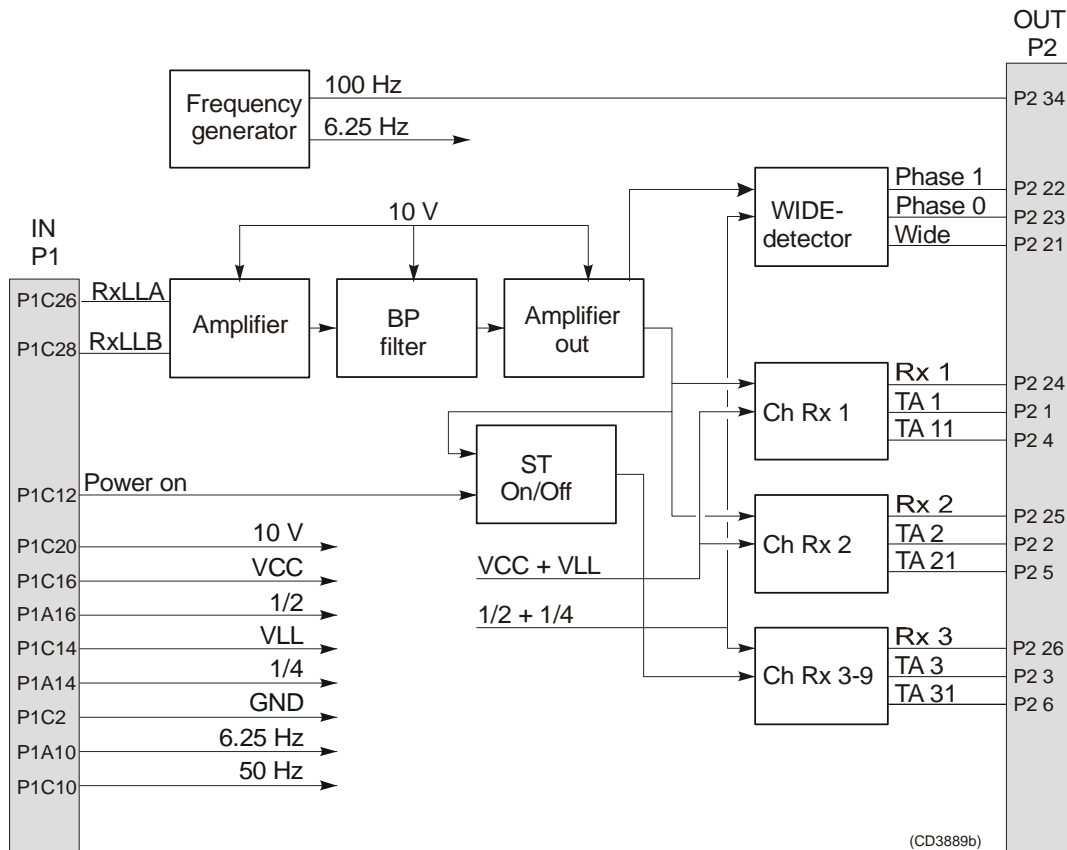

Figure 13 Receiver circuit board - block diagram

Microcontroller board

The Microcontroller board is a general purpose single microcontroller board, with the main task of performing calculations and digital signal control. It uses the *87C196KC/KD Microcontroller* manufactured by Intel, and is also equipped with a number of timers, inputs and outputs.

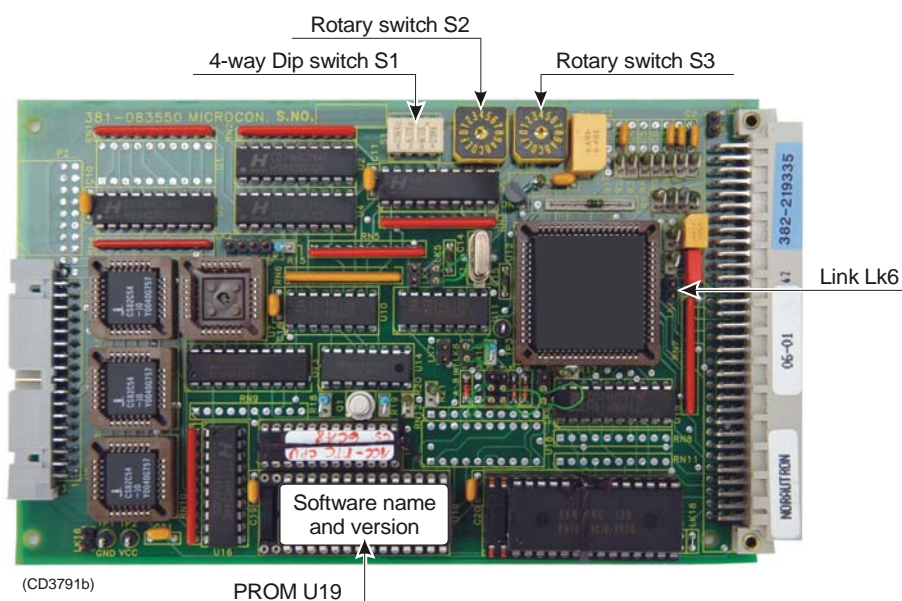

Figure 14 Microcontroller circuit board - switch locations

☞ Refer to figure 15 for the block diagram.

The 87C196 microcontroller is the main component on the board. It can be run in different modes such as active, idle and power down, the inactive modes being used to save power. The microcontroller performs all the calculations and controls all the board's inputs and outputs. The timers on the board are used for dividing down the off-board Phase-Locked-Loop frequencies, controlling the receiver frequency channels.

Switches

The board carries one 4-way Dip-switch block and two 10-position rotary switches:

- The Dip-switch block is used to set the system's operating frequency band.
 - **SI:** 1 = ON 2 = OFF 3 = OFF 4 = ON
 - **For small battery size (TTC 400 battery) -**
 - SI:** 1 = ON 2 = OFF 3 = OFF 4 = OFF

- Rotary switches
 - S2 can be set to 1
 - S3 can be set to 2

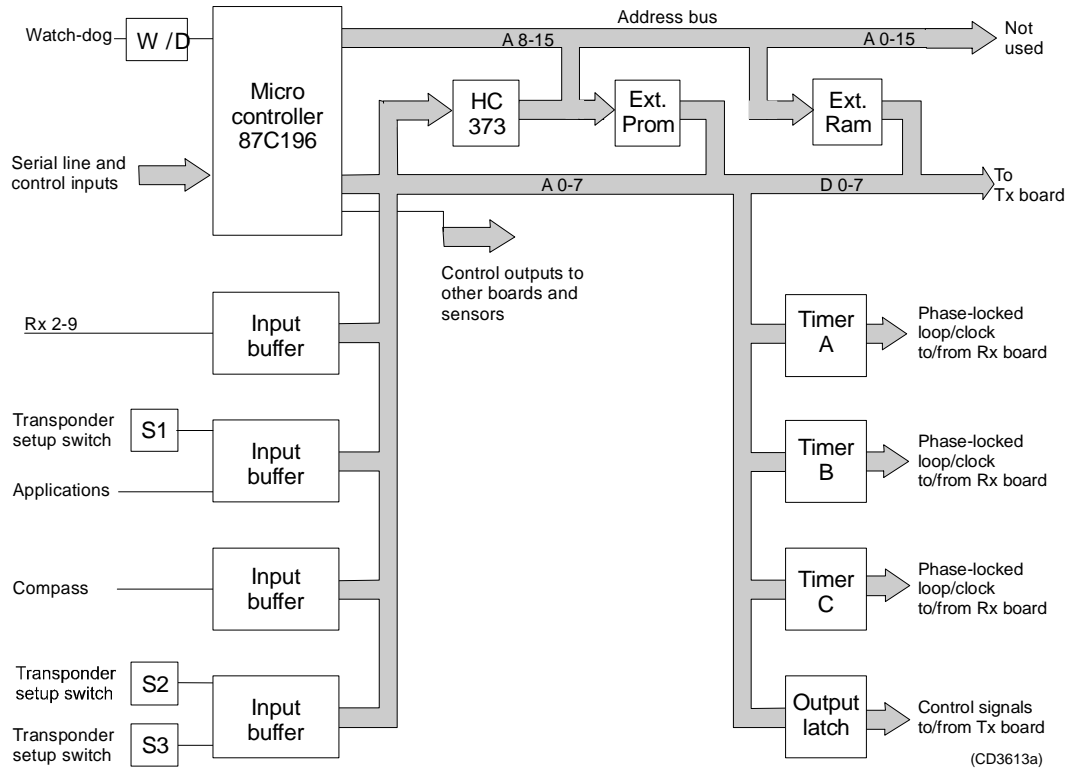

Figure 15 Microcontroller circuit board - block diagram

Battery charger board (Charger-2)

Charger

The charger is a Constant-Current / Constant-Voltage type charger with a temperature compensated output voltage.

The charger board consists of:

- A constant current source (U8) with a current sense (U7) which is used to control the charge indicator LED's.
- An adjustable constant voltage source (U5) with a shut-down transistor (Q1).
- External temperature sense input (BAT_PTC).



(Cd6988)

Figure 16 Battery charger board

The charger board should be supplied with 48 Vdc power. Initially the output voltage will be adjusted to 41.5 volt (in room temperature) with the adjustable resistor R1. The temperature correction will be approximately $-40 \text{ mV}/^\circ\text{C}$. The charger shut-down is activated from an external temperature sensor via an amplifier (U1) and a comparator (U3).

The shut-down will also be activated if a pos. signal is applied to the CHARGE_OFF input line. The verification of a shut-down status is that both charger LED's are switched off.

Note

When a shut-down has occurred, the input supply power must be removed in order to reset the shut-down mode.

Display Power

Logic power, 5V_LCD is generated with a linear voltage regulator (U12). This supply is also used to supply the back-light diodes (BL) and different circuits on the board, when the board is powered only from the battery terminals.

Display power (-15 V) is generated from a dc/dc converter built up around U10. This power supply have a 50 msec. start-up delay. The output voltage is temperature corrected with 50 mV/ °C (nominal output is -15 V at 25°C)

Power control

To power up the board:

- 1 SW1 must be switched on.
- 2 An external POWER_SWITCH must be switched on, or
- 3 link ST8 must be connected.

An external 5 V signal applied to the POWER_HOLD input line will also switch the power on.

If power-on should be inhibited while charging is in progress, link ST7 must be installed.

Responder Trig

A 10 Vdc signal with an output impedance of 1 kohm will be available at the RES_TRIG output when a logic signal is applied to the TX_EN input signal line. Signal delay from input to output is less than 1µs.

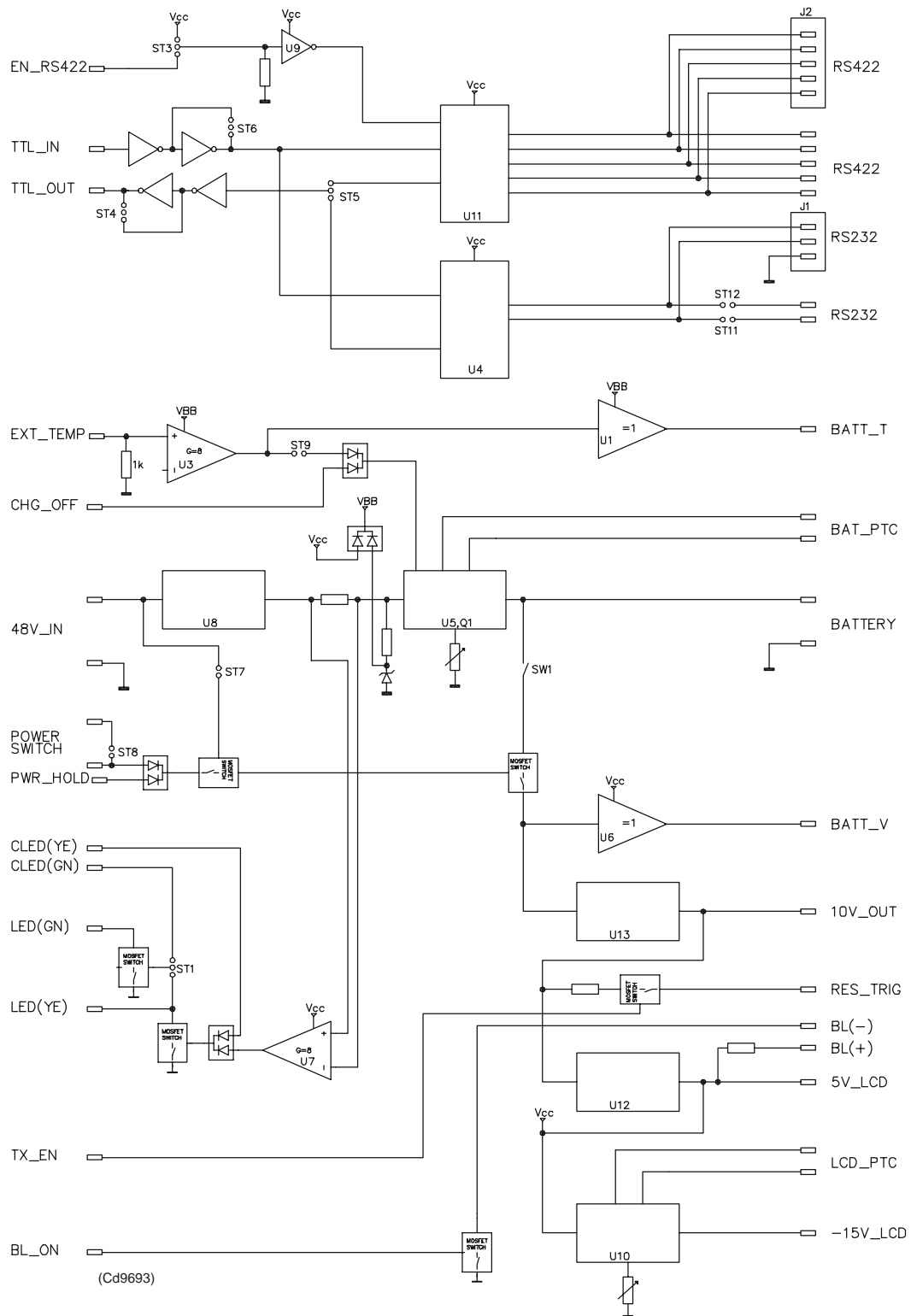

Motherboard

Description

The Motherboard contains all the interconnections between the:

- Microcontroller board
- Transmitter board
- Receiver board
- Battery charger board (Charger-2)
- AC power supply
- All signals and power to and from the Front panel unit and battery unit will also be connected to the TTC 400 Motherboard.

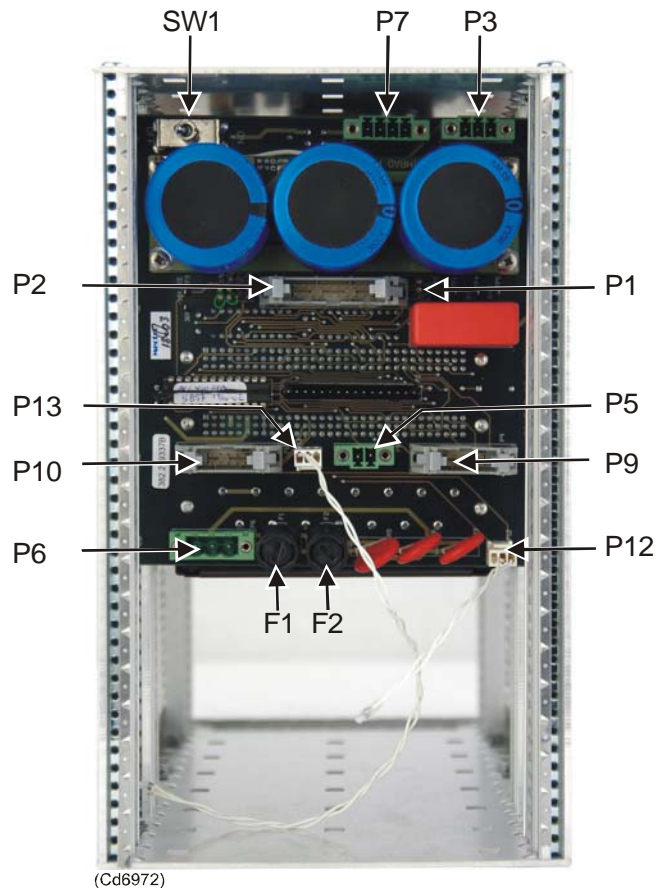

*Figure 17 Motherboard (solder side)
fitted in the cabinet*

The TX - CAP board is mounted piggy-back to the Motherboard. All the signals used by the display unit are buffered on the TTC 400 Motherboard (U2, U4). A DATA DIRECTION signal and a DATA READY signal are generated in PAL (U3) using the CLK, CE, RD, WR and ALE signals from the Microcontroller board.

Connectors

No.	Type	Connect to
J1	96 pins Euro-con	Transmitter board
J2	96 pins Euro-con	Receiver board
J3	96 pins Euro-con	Microcontroller board
J4	96 pins Euro-con	Battery charger board (Charger-2)
J5	32 pins Power-con	Ac Power

- Connectors J1 to J5 are placed on the component side, facing the rear of the cabinet. (Not shown in the figure on page 54.)

P1	20 pins 3M-con	LCD display unit
P2	16 pins SIL-con	Front panel
P3	3 pins Phoenix-con	Transducer
P5	2 pins Phoenix-con	Display back-light
P6	3 pins Phoenix-con	230 Vac
P7	4 pins Phoenix-con	Battery
P9	10 pins 3M-con	Non-isolated SL and Responder trig
P10	10 pins 3M-con	Optional isolated SL
P12	3 pins SIL-con	Battery thermistor
P13	3 pins SIL-con	LCD thermistor

- The connectors P1 to P13 are located on the solder side, facing the front of the cabinet. (See figure on page 54.)

Fuses

The Motherboard holds two ac mains fuses, F1 and F2. The fuses are located on the solder side.

Switches

The Motherboard holds one switch, SW1. The switch is located on the solder side.

Caution

Make sure that the switch SW1 is switched off before the battery plug is disconnected, and then switched on again when the battery plug is connected.

SPARE PARTS

Introduction

This section lists the parts and modules defined by Kongsberg Maritime as *Line Replaceable Units (LRUs)*. The required mounting components (such as nuts, bolts, washers etc.) have not been allocated order numbers as we regard these items as standard commercial parts available from retail outlets around the world.

TTC 400 unit

Complete unit

Part no.	Item name
125-217500	TTC 400 unit

Main modules

Part no.	Item name
382-219490	TX(MF) Transmitter board
382-083602	RX Receiver board MUTRAN
382-219335	Microcontroller board 16 MHz
499-217506	Front panel board
382-098602	Power supply
382-219052	Battery charger board
382-219337	Motherboard
380-219476	TTC 400 Mains Cable
290-220142	Battery pack

Options

Part no.	Item name
312-219494	Test and configuration TD with cable
380-219498	MPT responder cable, TTC 400
380-219496	MST responder cable, TTC 400

HELP FUNCTION

This pages presents the TTC 400 help function.

TTC 400 help

The TTC 400 includes a short help function. To activate the function, press the HELP button. (The Power must be switched on.)

Use the up / down arrows to scroll the text. To close the help text, use the left arrow. When you press the help button once more, the same lines of text as when you closed it, will be displayed.

Help text:

Use Arrows to operate the TTC.

UP/DOWN: Select a menu command

LEFT: CLOSE/Abort a command

RIGHT: Enter a Value or Start
a command.

POWER OFF: is the menu for
switching the TTC OFF,
otherwise the TTC will auto-
matically power OFF after
10 minutes.

Example, Test of TP 2001/B23:
Enter menu: TRANSPONDER
Select: NEW TRANSPONDER
Select TP SNo: 2001
Select Channel: B23

Press the Test TD against the
TP face and start the
command: INTERROGATE (TP)
Check if: REPLY OK or NO REPLY

For more information see
the Quick Reference Guide
or
the TTC 400 Instruction Manual

INDEX

The next pages presents the index of this manual.

A

About: *OPM Menus* 16
 AC power supply: *Main parts* 38
 AC power supply connector: *Main parts* 39
 Active function / command: *OPM Operation* 11
 Available transponders: *OPM SysDesc* 3

B

Bat: *OPM Operation* 10
 Battery: *Technical specifications* 4; *Main parts* 35, 36
 Battery charger board: *Main parts* 35, 51; *Spare parts* 56
 Battery lifetime: *Main parts* 36
 Battery pack: *Spare parts* 56
 Battery plug: *Main parts* 36
 Battery replacement: *Maintenance* 33
 Beam: *OPM Menus* 22

C

Ch: *OPM Operation* 10
 Channels: *OPM SysDesc* 3
 Charger–2: *Main parts* 35, 51
 Charging the battery: *Maintenance* 32
 Circuit boards: *Main parts* 35
 Compass: *OPM Menus* 30
 Connectors: *OPM SOP* 7

D

Depth & Temp: *OPM Menus* 29
 Disable: *OPM Menus* 25
 Display back–light plug: *Main parts* 41

E

Enable beacon: *OPM Menus* 25
 Enable RESP.: *OPM Menus* 25

Enable responder: *OPM Menus* 25
 Enable SSBL TP: *OPM Menus* 25
 Environment: *Technical specifications* 4

F

Frequency bands: *OPM SysDesc* 3
 Front panel board: *Spare parts* 56
 Front panel connector: *Main parts* 40
 Front panel plug: *Main parts* 43
 Front Panel Unit: *Main parts* 35
 Front panel unit: *Main parts* 40

H

HELP: *OPM SOP* 6
 HiPAP: *OPM SysDesc* 1, 3
 How to use the TTC 400: *OPM Operation* 9
 HPR: *OPM SysDesc* 1
 HPR 300: *OPM SysDesc* 3
 HPR 400: *OPM SysDesc* 3

I

Illustrations:
 Transponder top with test and configuration transducer: *OPM Operation* 9
 AC power supply: *Main parts* 38
 Battery charger board: *Main parts* 51
 Front panel board – rear side: *Main parts* 41
 Mains cable: *Maintenance* 32
 Microcontroller board (CPU): *Main parts* 50
 Microcontroller circuit board – switch locations: *Main parts* 49
 Motherboard: *Main parts* 54
 Receiver board (Rx): *Main parts* 47
 Receiver board (Rx) – block diagram: *Main parts* 48
 Transmitter circuit board: *Main parts* 45
 Transmitter circuit board – block diagram: *Main parts* 46
 TTC 400 – internal layout: *Main parts* 35
 TTC 400 internal battery: *Main parts* 36
 TTC 400 unit: *OPM SOP* 5
 TTC 400 unit and test and configuration transducer: *OPM SysDesc* 2

TTC 400 unit front panel: *OPM SOP 5*
 Inclinator: *OPM Menus 28*
 Interrogate: *OPM Menus 19*

L

LCD: *OPM SysDesc 1*
 LCD display: *OPM SOP 5*
 LCD display plug: *Main parts 42*
 LF: *OPM SysDesc 1*
 LIC Ch: *OPM Menus 22*
 LIGHT: *OPM SOP 6*
 Line Replaceable Units: *Spare parts 56*
 List of abbreviations: *OPM SysDesc 1*

M

Main parts: *Main parts 35*
 Mains Cable: *Spare parts 56*
 MAINTENANCE: *Maintenance 31*
 Manual contents: *OPM SysDesc 1*
 Master reset: *Maintenance 31*
 Menu description: *OPM Menus 12*
 MF: *OPM SysDesc 1*
 Microcontroller board: *Main parts 35, 49; Spare parts 56*
 Microcontroller board (CPU), Purpose: *Main parts 49*
 Motherboard: *Main parts 35, 54; Spare parts 56*
 MPT responder cable: *Spare parts 56*
 MST: *OPM SysDesc 1, 3*
 MST responder cable: *Spare parts 56*

N

NACK: *OPM Operation 11*
 New transponder: *OPM Menus 17*

O

OK: *OPM Operation 11*
 Opening the TTC 400 unit: *Maintenance 33*
 Operation: *OPM Operation 8*
 Options: *Spare parts 56*
 Org: *OPM Operation 10*

P

Page contents: *OPM Operation 10*
 PCB: *OPM SysDesc 1*
 POWER: *OPM SOP 6*
 Power off: *OPM Menus 30*
 Power supply: *Technical specifications 4; Main parts 35; Spare parts 56*
 Pulse L: *OPM Menus 22*
 Pushbutton functions: *OPM SOP 6*
 Pushbuttons: *OPM SOP 5*

R

Read battery status: *OPM Menus 20*
 Read parameters: *OPM Menus 22*
 Read TP sensor: *OPM Menus 28*
 Receiver board: *Main parts 47*
 Receiver board (Rx): *Main parts 35 Purpose: Main parts 47*
 Receiver sensitivity: *Technical specifications 4*
 Release: *OPM Menus 27*
 Remove the rack: *Maintenance 33*
 Replace the rack: *Maintenance 33*
 Replacing the circuit boards: *Maintenance 34*
 Reset: *OPM Menus 26*
 Reset to factory set: *OPM Menus 14*
 Responder trig plug: *Main parts 44*
 RPT: *OPM SysDesc 1, 3*
 RSP: *OPM SysDesc 1*
 Rx: *OPM SysDesc 1; Main parts 47*
 Rx Gain: *OPM Operation 10*

RX Receiver board : *Spare parts 56*

S

Scan for CH w/Reset: *OPM Menus 23*

Select transponder: *OPM Menus 18*

Set parameters: *OPM Menus 21*

Set TP mode: *OPM Menus 25*

SNo: *OPM Operation 10*

Source level: *Technical specifications 4*

Spare parts: *Spare parts 56*

Submenus description: *OPM Menus 14*

Switch channel: *OPM Menus 24*

SYSTEM DESCRIPTION: *OPM SysDesc 1*

T

TAD: *OPM Menus 22*

TD: *OPM SysDesc 1*

TD with cable: *Spare parts 56*

TECHNICAL SPECIFICATIONS: *Technical specifications 4*

Test and configuration TD with cable: *Spare parts 56*

Test transducer: *Technical specifications 4*

TP: *OPM SysDesc 1; OPM Operation 10*

TP function submenu: *OPM Menus 23*

Transducer plug: *Main parts 43*

Transmitter board : *Main parts 45*

Transmitter board (Tx): *Main parts 35*

Transponder submenu: *OPM Menus 17*

Transponders: *OPM SysDesc 3*

TTC: *OPM Operation 10*

TTC 400 front Panel: *OPM SOP 5*

TTC 400 front panel: *OPM SOP 5*

TTC 400 unit: *OPM SysDesc 2; Spare parts 56*

TTC parameters submenu: *OPM Menus 14*

TTC setup: *OPM Menus 15*

Tx: *OPM SysDesc 1; Main parts 45*

Tx Power: *OPM Operation 10*

TX(MF) Transmitter board: *Spare parts 56*

U

Units: *Main parts 35*

Units dimensions: *Technical specifications 4*

V

v: *OPM Operation 10*

Vac power plug: *Main parts 43*

vxx: *OPM Menus 22*

Blank page