



KONGSBERG

# Installation manual

## EM 2000

Multibeam echo sounder

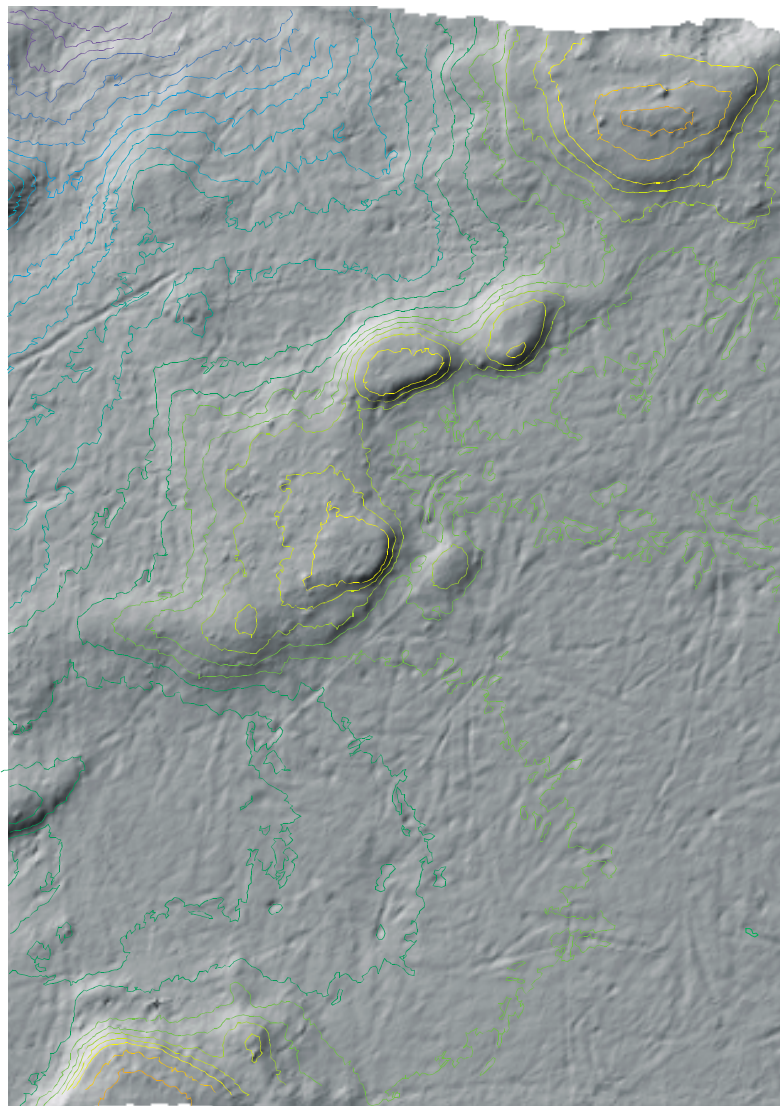



851-164261

***EM 2000***  
***Installation manual***

## About this document

Rev	Date	Written by	Checked by	Approved by
D	25.11.05	ASM	GFS	GFS
Updated layout, minor corrections in the text.				

© 2005 Kongsberg Maritime AS. All rights reserved.

No part of this work covered by the copyright hereon may be reproduced or otherwise copied without prior permission from Kongsberg Maritime AS.

The information contained in this document is subject to change without prior notice. Kongsberg Maritime AS shall not be liable for errors contained herein, or for incidental or consequential damages in connection with the furnishing, performance, or use of this document.

### **Kongsberg Maritime AS**

Strandpromenaden 50  
P.O.Box 111  
N-3191 Horten,  
Norway

Telephone: +47 33 02 38 00  
Telefax: +47 33 04 47 53  
**www.kongsberg.com**  
E-mail: subsea@kongsberg.com



**KONGSBERG**

## Remarks

### References

Further information about the EM 2000 system supplied to Base version may be found in the following manuals:

- EM 2000 Operator manual
- EM 2000 Maintenance manual

### The reader

This Installation manual is intended for the design and installation engineers at the shipyard performing the installation. The information is supplied as the basis for the shipyard's own installation drawings applicable to the vessel. On completion of the installation, this manual must be kept on the vessel for reference purposes during system maintenance.

### Note

This manual is issued according to a registered distribution list. In the event of changes to this manual, only authorized copies with copy numbers will be updated.

<b>1</b>	<b>PURPOSE AND DESCRIPTION</b>	<b>1</b>
1.1	General	1
1.2	System overview	2
1.3	General safety rules	5
1.4	Supply conditions	6
	Equipment responsibility	6
	Installation guidelines	6
	Assistance from Kongsberg Maritime	6
	Terms and conditions	6
1.5	Installation requirements	8
	Supply power	8
	Environmental requirements	8
	Noise sources	8
	Dry docking	9
	Wiring	9
1.6	Equipment handling	10
	Introduction	10
	Transportation	10
	Initial preservation	11
	Inspection and unpacking	13
	Storage	16
	After use storage	17
	Re-packing	19
	ESD precautions	19
	Temperature protection	20
<b>2</b>	<b>TECHNICAL SPECIFICATIONS</b>	<b>21</b>
	Interfaces	21
	Physical specifications	22
	Environmental specifications	23
<b>3</b>	<b>OPERATOR STATION</b>	<b>24</b>
3.1	Description and main functions	24
	Introduction	24
3.2	Theory	25
	Overview	25
	Software	25
	Data storage	25
3.3	Installation	26
<b>4</b>	<b>PROCESSING UNIT</b>	<b>27</b>
4.1	Introduction	27
4.2	Processing Unit Installation	28
	Description	28
	Location	28
	Installation	28

<b>5</b>	<b>SONAR HEAD &amp; TRANSMIT TRANSDUCER</b>	<b>29</b>
5.1	Introduction	29
5.2	General requirements	30
5.3	Locating the sonar heads	32
	General	32
	The boundary water layer	32
	Propeller noise	33
	Noise from protruding objects on the hull	34
	Bulbous bow	34
	Summary	34
5.4	Installation	36
	Introduction	36
	External mounting	36
	Keel mounting	37
	Retractable hull unit mounting	37
	Flush mounting	37
	Preliminary mounting	38
	Mounting on subsea vehicle	39
	Cabling	39
<b>6</b>	<b>SUBSEA VEHICLE INSTALLATION</b>	<b>40</b>
6.1	Introduction	40
6.2	Principal solutions	41
6.3	Processing Unit on the mother vessel	43
6.4	Processing Unit on the subsea vehicle	47
	Standard Processing Unit	47
	AUV Processing Unit	47
<b>7</b>	<b>EXTERNAL INTERFACES</b>	<b>48</b>
7.1	Introduction	48
7.2	External synchronization	49
7.3	1PPS	51
<b>8</b>	<b>CABLE LAYOUT</b>	<b>52</b>
8.1	Introduction	52
8.2	System cabling	53
	Cable layout	53
	System and shipyard cables	53
8.3	Cable plan	54
8.4	Cable specifications	57
	Operator Station cables	57
	Processing Unit cables	59
	AUV Unit Cables	60

8.5	Cable drawing list	62
	Generic RS-232 Serial line	63
	Generic coax cable	64
	Generic RS-232 with CTS and RTS	65
	Sound speed probe interface	66
	RS-232 Serial line with Trigger signals	67
	RS-485 Serial line and power	68
	Mini Coax	69
	Standard AC power cable	70
	EMC ground	71
	Ethernet with RJ45 plugs (screened)	72
	Ethernet with IEEE 802.3	73
	Standard USB cable	74
	Keyboard cable	75
	Mouse or pointing device cable	76
	Printer cable	77
	Digital Video Interface (DVI) display cable	78
	W600 - Remote synchronization	79
	W807 - Sonar Head cable	80
8.6	Sonar Head cable drawings	81
	Standard Sonar Head cable	82
	AUV Sonar Head cable	83
8.7	Sonar Head Connection	84
	Sonar Head cable	84
	Internal wiring inside the bottle	84
	Serial Line Board (CI-104JS)	85
	4-Ports Serial Line Board (C114P)	87
8.8	Basic cabling requirements	89
<b>9</b>	<b>ALIGNMENT</b>	<b>92</b>
9.1	Introduction	92
9.2	Measurements	93
	Objectives	93
	Vessel coordinate system	94
	Sensor location	94
	Measurement accuracy	96
9.3	Heading sensor calibration	99
9.4	Summary	100



<b>10</b>	<b>INSTALLATION CHECKS</b> .....	<b>101</b>
10.1	Visual inspection of units .....	101
	Scope .....	101
	Inspections .....	101
10.2	Electrical checks .....	102
	Scope .....	102
	Cabling .....	102
	Operational voltages .....	103
10.3	Final checks .....	104
<b>11</b>	<b>DRAWING FILE</b> .....	<b>105</b>
11.1	Overview .....	105
	Standard Processing Unit drawing .....	110
<b>12</b>	<b>INDEX</b> .....	<b>114</b>



## High voltage safety warning

The voltages used to power this equipment are potentially lethal. Even 110 volts can kill.

Whenever possible, the following precautionary measures should be taken before any work is carried out inside the equipment:

- Switch off all high-voltage power supplies.
- Check the operation of any door interlocks and any other safety devices.
- Completely discharge all high-voltage capacitors.

It should be noted that interlocks and safety devices are normally located only at regular access points, and high voltages may be exposed during dismantling.

### NEVER WORK ALONE ON HIGH-VOLTAGE EQUIPMENT!

### FIRST AID IN THE EVENT OF ELECTRIC SHOCK

Normally, even a high voltage electric shock will not kill instantly. The victim can still be revived even when his breathing and heart-beat have ceased.

Could **YOU** save someone's life? In the event of electric shock, the correct actions, performed quickly may well save the victim's life. **Make sure you know what to do!**

#### Immediate action

While shouting for help, remove the source of power from the victim. Switch off the supply if possible, or using a dry, non-conductive material (rubber gloves, broom handle etc.) to insulate yourself, separate the victim from the source. If the voltage exceeds 1000 volts, switch off the supply and be ready to catch the victim. Take care- do not become a victim yourself.

Commence first aid on the spot. Continue to shout for assistance till someone arrives.

- 1 Lay the victim flat on his back and loosen any tight clothing (collar, tie, belt etc.).
- 2 Open his mouth and check for and remove any false teeth, chewing gum etc.
- 3 Check if the victim is breathing. If not, check if his heart is beating. The pulse is normally easily found in the main arteries of the neck, either side of the throat, up under the chin.

If his heart is beating but he is not breathing, commence **ARTIFICIAL RESPIRATION**. If the victim's heart is not beating, commence **EXTERNAL CARDIAC MASSAGE (ECM)**. Continue to shout for assistance till someone arrives.

### EXTERNAL CARDIAC MASSAGE

- 1 Kneel beside the victim. Place the heel of one hand in the centre of his chest, at a position half way between the notch between the collar-bones at the top of his chest, and the dip in the breast-bone at the base of his rib cage. Place the other hand on top of the first.
- 2 Keeping the arms straight and using your entire weight, press down rapidly so that the breast bone is depressed four- five cm, then release the pressure. Repeat rhythmically at a rate of one cycle per second. This will be hard work, but keep going. His life depends on **YOU**. Do not worry about breaking his ribs - these will heal if he survives.



### ARTIFICIAL RESPIRATION

- 1 Kneel beside the victim's head. Place one hand under his neck and lift, allowing his head to fall back. This will lift his tongue and open the air passage in his throat.
- 2 Place the palm of the hand on his forehead to maintain the "chin-up" position.
- 3 Using the index finger and thumb of the same hand, pinch the victim's nostrils closed. Open his mouth.
- 4 Take a deep breath and cover his mouth with yours. Blow steadily into his lungs to expand his chest. Remove your mouth from his to allow the air to escape from his chest. You should be able to see his chest deflate.
- 5 Repeat the "inflation-deflation" cycle at a rate of about 12 cycles per minute till the victim begins to breath normally again.

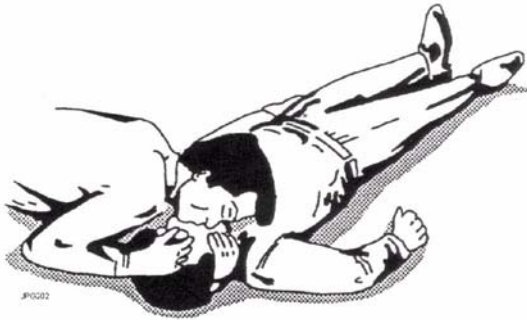

### COMBINING EMC AND ARTIFICIAL RESPIRATION

If you are alone, perform **ONE** cycle of artificial respiration for every **FIVE** cycles of EMC. This will be hard work, but keep going. His life depends on **YOU!**

If there are other people available to help, one should perform the EMC while one performs the artificial respiration for every five cycles of EMC. It will be much more efficient with two people.

Once the victim's heart is beating and he is breathing, roll him onto his side and support him in that position. As consciousness returns he may vomit, and this will allow any liquid to drain out of his mouth.

Remove the victim to a hospital as soon as possible, but do not interrupt the artificial respiration and EMC cycles till his heart beat and breathing returns.

If started quickly and performed correctly, the resuscitation methods described will keep a sufficient volume of oxygenated blood flowing through the victim's body to allow full recovery.

Proficiency in the resuscitation methods can only be achieved through training. All personnel concerned should attend courses on a regular basis. Remember, someone's life could depend on you.



**DO YOU KNOW WHAT TO DO?**

# 1 PURPOSE AND DESCRIPTION

## 1.1 General

The purpose of this installation manual is to present the descriptions and drawings required to install the EM 2000 multibeam echo sounder system.

This manual is common for the AUV Processing Unit and the Standard Processing Unit.

---

Note

*Detailed vessel specific mechanical drawings for the installation must be provided by the customer, or any shipyard contracted to perform the installation. Kongsberg Maritime AS may, on special order, supply these drawings. Drawings must be approved by the appropriate vessel certification authority prior to installation of the system.*

---

The manual also defines the equipment responsibility, and provides instructions for unpacking and storage.

---

Note

*The installation instructions given in this document must be adhered to. Failure to do so may render the guarantee void.*

---

No special tools are generally required to perform installation, removal and replacement of modules and parts. When special tools are required, these are listed in the installation procedure.

### Topics

- *System overview, page 2*
- *System diagram, page 3*
- *General safety rules, page 5*
- *Supply conditions, page 6*
- *Installation requirements, page 8*
- *Equipment handling, page 10*

## 1.2 System overview

The EM 2000 multibeam echo sounder is a shallow water mapping and inspection system with very high accuracy and resolution.

The minimum operating depth is from less than 2.5 m below its transducers, and in typical sea water conditions the system operates to 350 to 400 m depth (less in warm water and more in fresh water). Small dimensions and low weight makes the system portable and easy to install allowing use both on survey launches and subsea vehicles to 6000 m water depth.

The EM 2000 system has a high ping rate of up to 10 Hz. It operates with 111 roll stabilised beams per ping with 1.5° beamwidth along and 1.5° across-track dependent upon sonar head model. With the narrowest across-track beamwidth the system has an angular coverage of more than 120 degrees, and with the widest the angular coverage is more than 150 degrees. The achievable coverage may be more than to 300 m. The beam spacing is operator adjustable to be either equiangular, equidistant or in-between. Angular coverage is also operator adjustable, always retaining the full number of beams within the defined coverage sector.

The system sonar frequency is 200 kHz, allowing small dimensions, good range capability and high tolerance to turbid waters.

Integrated seabed acoustical imaging capability (sidescan) is included as standard. A combination of phase and amplitude detection is used, resulting in a measurement accuracy of 8 cm RMS being achievable practically independent of beam pointing angle.

The EM 2000 is a complete system with all necessary sensor interfaces, real-time compensation for vessel motion and ray-bending, data displays for quality control including sensor calibration, and data logging included as standard.

Postprocessing software for the EM 2000 is available from both Kongsberg Maritime and third-party suppliers. A world-wide marketing and service organization having many years of multibeam experience is available for supporting the EM 2000.

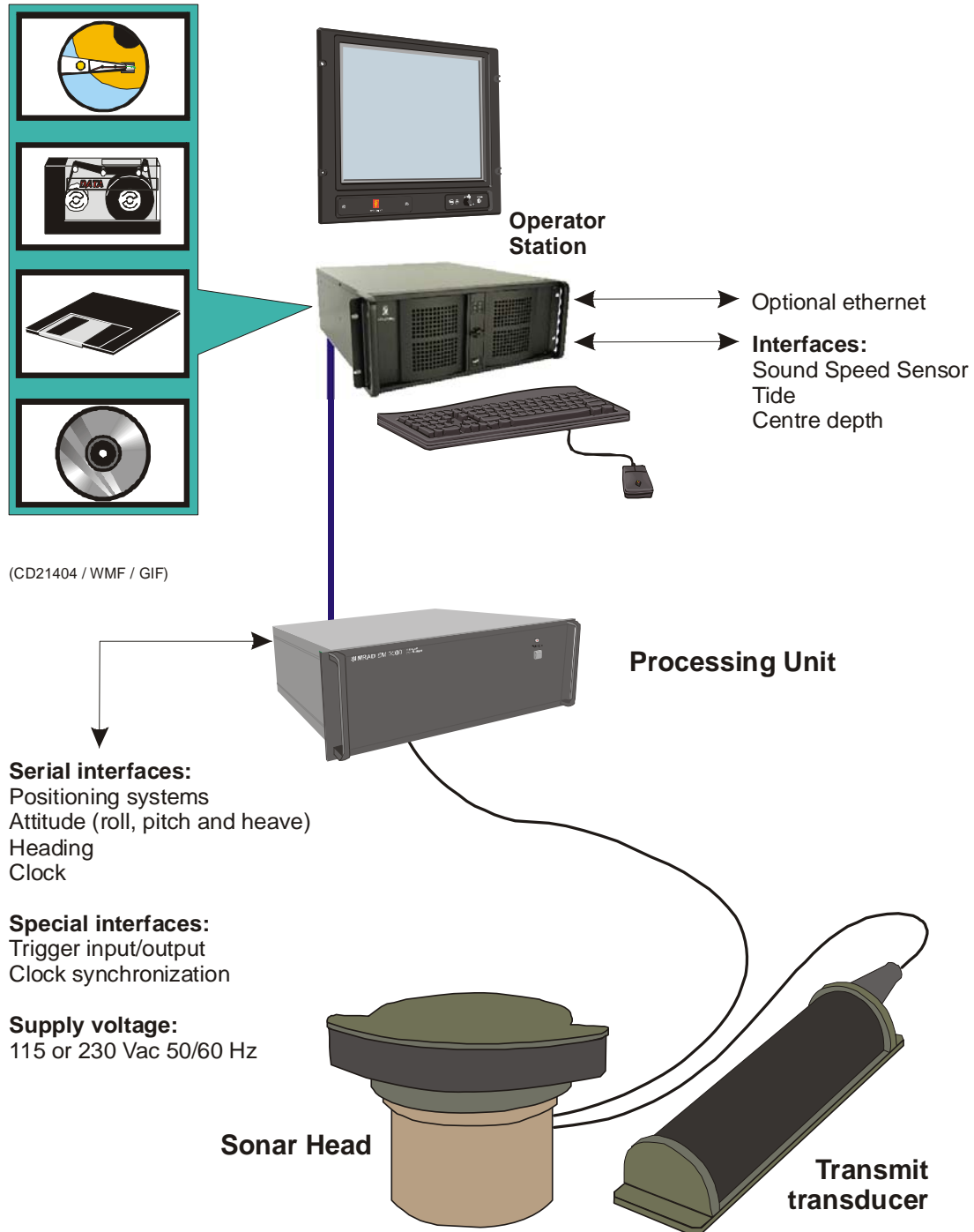
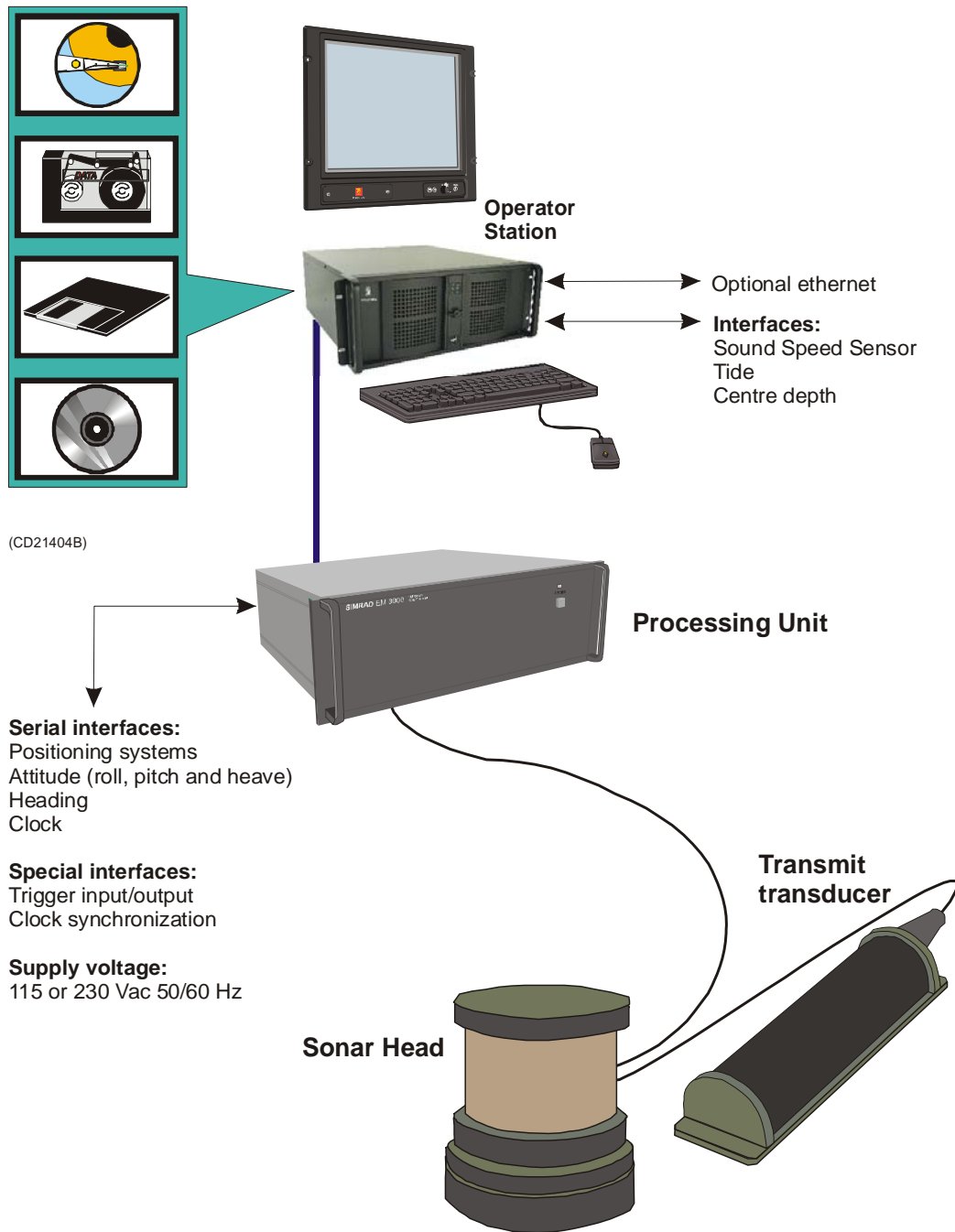

Figure 1 EM 2000 system units and interfaces, 120 degrees sonar head



(CD21404B)

Figure 2 EM 2000 system units and interfaces, 150 degrees sonar head



## 1.3 General safety rules

The system operates on 115 and/or 230 Vac, 50/60 Hz without any need for wiring changes.

### **Warning**

***This voltage can be lethal.***

The following safety precautions must be followed at all times during installation and maintenance work:

- Always switch off all power before installation or maintenance. Use the main circuit breaker, and label the breaker with a warning sign that informs others that maintenance or installation work is being carried out on the system.
- Read and understand the first aid instructions for electric shock.
- For safety reasons during troubleshooting on the equipment with power ON, two persons should always be present.
- Whenever maintenance is carried out, it is essential that a first aid kit is available, and that the maintenance personnel are familiar with the first aid instructions for electrical shock.
- The various parts of the system are heavy. Make sure that the appropriate tools and certified lifting equipment are available, and that the personnel are trained in installation and maintenance work.

## **1.4 Supply conditions**

### **Equipment responsibility**

Upon receipt of the EM 2000 system units the installation shipyard automatically becomes fully responsible for the equipment. This responsibility covers the storage period before installation, the actual installation, and the period between the completion of the installation and the acceptance of the equipment by the end user or owner.

### **Installation guidelines**

During the installation period the equipment must be covered in such a way that it is protected from dust, paint spray/splashes and welding/cutting sparks. Precautions must be taken to ensure that no part of the equipment is used as a work platform, or for any other purpose for which it was not designed.

Any damage incurred during the installation period, even with a Kongsberg Maritime AS representative present, is the installation shipyard's responsibility unless it can be proven that the damage was due to production or material defects in the equipment delivered by Kongsberg Maritime AS, or irresponsibility by Kongsberg Maritime AS personnel.

### **Assistance from Kongsberg Maritime**

Kongsberg Maritime AS may assist during the installation if specified in the contract or requested by the installation shipyard or customer. Kongsberg Maritime AS may also assist with installation drawings. All such assistance is charged to the customer at the current rates.

If required during a contractual test period, the shipyard must provide assistance necessary for the rapid and efficient completion of the work even when the work is to be performed outside normal working hours. This requirement includes assistance from subcontractors when applicable. Excessive waiting time resulting from delays caused by the shipyard will be charged to the shipyard.

### **Terms and conditions**

Kongsberg Maritime' Conditions of Sale shall apply, unless otherwise specifically stated in the quotation and in the below terms and conditions.

The warranty period, for hydrographic echo sounders and sonars as well as software for these instruments, is 24 months from date when the equipment is sent from the factory. For all other equipment and systems which are delivered, the respective manufacturers warranty terms are applied.

Kongsberg Maritime offers **maintenance contracts** that may extend the warranty period for a period as defined in the contract.

Kongsberg Maritime will take full system responsibility for the system as delivered by Kongsberg Maritime. The equipment is to be delivered FCA, Horten, Norway. Incoterms 2000.

## 1.5 Installation requirements

### Supply power

The supply voltage to the equipment is to be kept within  $\pm 10\%$  of the installation's nominal voltage. Maximum transient voltage variations on the main switchboard's bus-bars are not to exceed  $-15\%$  to  $+20\%$  of the nominal voltage (except under fault conditions).

Kongsberg Maritime strongly recommends that the EM 2000 Operator Station is powered through an Uninterruptible Power Supply (UPS). The UPS should have the capacity to independently maintain power for a minimum of 10 minutes. This ensures that the system can be switched off in a controlled manner in the event of a power failure.

### Environmental requirements

#### Vibrations

If the equipment is expected to be exposed to excessive vibration for extended periods, special dampening precautions must be taken.

#### Temperature and humidity

All equipment, unless otherwise specified, must be protected from temperature extremes and excessive humidity.

→ Refer to "Ambient temperature and humidity" on page 12 for more information.

#### Noise sources

The vessel's hull, rudder(s) and propeller(s) should be thoroughly inspected in dry dock prior to installation. Roughness below the water-line deformities in the shell plating and protruding obstacles can create underwater noise. These sources of turbulence must be smoothed or removed as best as possible. It is especially important that the propeller(s) is not pitted or damaged.

### **Dry docking**

Make sure that ample clearance under the sonar trunk and/or protection blister is provided when dry docking the vessel. Avoid locating supporting blocks or structures in the vicinity of this equipment.

---

Note

*The location of the sonar trunk and/or protection blister must be noted on the vessel's docking plan for future reference.*

---

### **Wiring**

The cables between the bridge, the various operation rooms and equipment rooms must be supported and protected along their entire lengths using conduits or cable trays. Note that the cables must not be installed in the vicinity of high-power supplies and cables, antenna cables or other possible sources of interferences.

## 1.6 Equipment handling

### Introduction

This section describes how to transport, pack and unpack, clean, preserve and store electronic, electro-mechanical and mechanical units supplied by Kongsberg Maritime AS.

The units may be supplied as spare parts, or as parts of a delivery.

### Transportation

#### General specifications

Unless otherwise stated in the accompanying documentation, electronic, electro-mechanical and mechanical units supplied by Kongsberg Maritime can be transported using all methods approved for delicate equipment; (by road, rail, air or sea). The units are to be transported in accordance with general or specific instructions for the appropriate unit(s), using pallets, transport cases, or carton boxes as appropriate.

---

#### Note

*Special local restrictions concerning air transportation may be applied to units containing certain types of batteries. The units should be checked and the regulations investigated by the packer/shipper before the unit is dispatched.*

---

#### Local transportation

All local transportation must be carried out according to the same specifications as for the initial delivery. In general, all units must be handled with care. The carton or case containing the equipment must be kept dry at all times, and must be sheltered from the weather. It must not be subjected to shocks, excessive vibration or other rough handling.

The carton or case will normally be marked with text or symbols indicating which way up it is to be placed. Follow any instructions given and ensure the case is always placed with its “top” uppermost.

The carton or case must not be used for any purpose for which it was not intended (step, table, etc.), and in the absence of other information, no other cartons or cases must be stacked on top of it.

## Lifting

A heavy crate will normally be marked with its weight, and the weights of other cartons or crates will normally be entered on the packing list.

- Always check the weight of a crate before attempting to lift it.
- Always use lifting apparatus that is certified for the load.

Heavy units may be equipped with lifting lugs for transportation by crane within the workshop or installation area. Before a crane is used, check:

- The applicable weight certificate for the crane.
- The security of the lifting lugs.

Ensure that all available lifting lugs are used. Ensure the unit remains under control during the operation to avoid damage to the unit, equipment or personnel.

Heavy units may be transported using a fork-lift truck. Special attention must then be paid to the position of the unit's centre of gravity. The units must be properly secured to the truck.

## Initial preservation

### Introduction

When a system, a unit or a spare part has been delivered to the customer, it may be subject to long-time storage prior to installation and use. During this storage period, certain specifications must be met.

The equipment must be preserved and stored in such a way that it does not constitute any danger to health, environment or personal injury.

Specific specifications are presented below.

- *For further information about storage, refer to page 16.*
- *For further information about re-packing, refer to page 19.*
- *For further information about temperature protection, refer to page 20.*

### Original packing crate

- 1 The equipment must be stored in its original transportation crate.
- 2 Ensure that the units are clearly separated in the shelves and that each unit is easily identifiable.
- 3 The crate must not be used for any purpose for which it was not intended (eg. work platform etc.).

- 4 The crates must not be placed on top of each other, unless specific markings permit this.
  - 5 The crates must not be placed directly on a dirt-floor.
  - 6 Do not open the crate for inspection unless special circumstances permit so.
    - “Special circumstances” may be suspected damage to the crate and its content, or inspections by civil authorities.
    - If any units are damaged, prepare an inspection report stating the condition of the unit and actions taken. Describe the damage and collect photographic evidence if possible. Re-preserve the equipment.
    - If the units are not damaged, check the humidity absorbing material. If required, dry or replace the bags, then repack the unit(s) according to the packing instructions.
  - 7 If the crate has been opened, make sure that it is closed and sealed after the inspection.
    - Use the original packing material as far as possible.
- *Refer to information on page 19.*

#### **Ambient temperature and humidity**

- 1 The storage room/area must be dry, with a non-condensing atmosphere. It must be free from corrosive agents.
- 2 The storage area’s mean temperature must not be lower than -30° C, and not warmer than +70° C.
  - If other limitations apply, the crates will be marked accordingly.

Note

---

*Transducers must not be stored in temperatures below -20° C, or higher than +60° C.*

---

- 3 The crate must not be exposed to moisture from fluid leakages.
- 4 The crate must not be exposed to direct sunlight or excessive warmth from heaters.

#### **Shock and vibration**

- 1 The crate must not be subjected to excessive shock and vibration.

#### **ESD precautions**

→ *Refer to the information on page 19.*



## Batteries

If the unit contains normal batteries, these may have been disconnected/isolated before the unit was packed. These must only be reconnected before the installation starts. Units containing batteries are marked.

---

### Caution

*Units containing lithium or alkaline batteries must be handled separately and with care. Such units are marked accordingly. Do not attempt to recharge such batteries, open them or dispose of them by incineration. Refer to the applicable product data sheets.*

---

## Inspection and unpacking

### Inspection

An inspection must be carried out immediately after the unit(s) have arrived at their destination.

- Check all wooden or cardboard boxes, plastic bags and pallets for physical damage. Look for signs of dropping, immersion in water or other mishandling.
- If damage is detected externally, you will have to open the packaging to check the contents.
  - Request a representative of the carrier to be present while the carton is opened, so any transportation damage can be identified.
- If any units are damaged, prepare an inspection report stating the condition of the unit and actions taken. Describe the damage and collect photographic evidence if possible. Send the inspection report to Kongsberg Maritime as soon as possible.
- If the units are not damaged, check the humidity absorbing material. If required, dry or replace the bags, then repack the unit(s) according to the packing instructions.

### General unpacking procedure

Normal precautions for the handling, transportation and storage of fragile electronic equipment must be undertaken.

---

#### Note

*If the unit is not to be prepared for immediate use, you may consider storing it unopened in its original packing material. However, it may be useful to open the case to check its contents for damage and retrieve any accompanying documentation.*

---

- Check the carton before opening it to ensure it shows no signs of dropping, immersion in water or other mishandling.
    - If the carton shows signs of such damage, refer to the paragraph covering Inspection on receipt.
  - Place the carton on a stable work bench or on the floor with the top of the carton uppermost.
  - In the absence of other instructions, always open the top of the carton first. The contents will normally have been lowered into the carton from above, so this will usually be the easiest route to follow.
    - Care must be used when opening the carton to ensure the contents are not damaged.
- 

#### Caution

*Do not use a knife to open cardboard cartons - the contents may lie close to the surface, and may be damaged by the blade.*

---

- If the carton has been closed using staples, remove the staples from the carton as you open it. This will reduce the possibilities of scratch injury to yourself and damage to the contents.
- If a wooden crate has been closed using screws, always remove them using a screw-driver. Do not attempt to prise the lid off with a crow-bar or similar.
- Once the carton is open, carefully remove all loose packing and insulation material. Check for manuals and other documents that may have been added to the carton during packing, and put these to one side. Check also for special tools, door keys etc.

## Electronic and electro-mechanical units

---

*Caution*

*Beware of the dangers of Electro-Static Discharge (ESD) both to yourself and to the equipment, when handling electronic units and components. Refer to the precautions starting on page 19.*

---

Electronic and electro-mechanical units will normally be wrapped in a clear plastic bag. Lift the unit, in its bag, out of the carton and place it in a stable position on the floor/work bench.

Inspect the unit for damage before opening the plastic bag.

---

*Note*

*Cables must **never** be used as carrying handles or lifting points.*

---

*Note*

*Do not break the seal to open a circuit board package before the board is to be used. If the board package is returned to the manufacturers with the seal broken, the contents will be assumed to have been used and the customer will be billed accordingly.*

---

Assuming all is well, open the bag and remove the unit.

Open the unit and check inside. Remove any packing and desiccant material that may be inside.

### **Mechanical units**

Mechanical units may be heavy. Using a suitably certified lifting apparatus, lift the unit out of the crate and place it in a stable position on the floor/work bench.

Inspect the unit for damage and remove any packing material that may be inside the unit.

### **Transducers**

Transducers may be supplied mounted to a hull unit (if any), or packed separately. Crates are normally identified by the order number and the serial number.

The transducer face must be protected by a rigid, padded cover (e.g. a wooden box lined with foam rubber) all the time it is exposed to the risk of physical damage.

---

Note

*Once the units are unpacked, great care must be taken to ensure that transducers and cabling are not exposed to any mechanical stress.*

---

### **Re-packing**

If the unit is not to be installed immediately, re-pack it in its original packing material to prevent damage in the intervening period.

→ *Refer to the information on page 19.*

### **Storage**

#### **Pre-installation storage**

The equipment should be stored in its original transportation crate until ready for installation. The crate must not be used for any purpose for which it was not intended (eg. work platform etc.).

Once unpacked, the equipment must be kept in a dry, non condensing atmosphere, free from corrosive agents and isolated from sources of vibration.

---

Note

*Do not break the seal to open a circuit board package before the board is to be used. If the board package is returned to the manufacturers with the seal broken, the contents will be assumed to have been used and the customer will be billed accordingly.*

---

The unit must be installed in its intended operating position as soon as possible after unpacking.

If the unit contains normal batteries, these may have been disconnected/isolated before the unit was packed. These must then be reconnected during the installation procedure. Units containing batteries are marked.

**Caution**

*Units containing lithium or alkaline batteries must be handled separately and with care. Such units are marked accordingly. Do not attempt to recharge such batteries, open them or dispose of them by incineration. Refer to the applicable product data sheets.*

---

**After use storage****Introduction**

If a unit is removed from its operating location and placed into storage, it must be properly cleaned and prepared before packing.

**Cleaning cabinets**

If a cabinet has been exposed to salt atmosphere while it was in use, it must be thoroughly cleaned both internally and externally to prevent corrosion.

- Wipe the cabinet externally using a damp cloth and a little detergent. Do not use excessive amounts of water as the unit may not be water tight. On completion, dry the unit thoroughly.
- All surfaces must be inspected for signs of corrosion, eg. flaking/bubbling paint, stains etc. Damaged or suspect areas must be cleaned, prepared and preserved using the correct preservation mediums for the unit. The mediums to be used will usually be defined in the units' maintenance manual.
- Open the unit, and using a vacuum cleaner, remove all dust etc. from the unit. Great care must be taken to ensure the circuit boards and modules are not damaged in the process.

**Mechanical units**

If a mechanical unit may have been exposed to a salt atmosphere while it was in use, it must be thoroughly cleaned both internally and externally to prevent corrosion.

- If the construction materials and type of unit permits, wash the unit using a high-pressure hose and copious amounts of fresh water.

Examples:

- The lower parts of hull units (outside the hull)
- Subsea units

- Ensure that all traces of mud and marine growth are removed. Use a wooden or plastic scraper to remove persistent growth, barnacles etc. On completion, dry the unit thoroughly.
- 

*Caution*

*Do not use a high pressure hose in the vicinity of cables or transducers. Do not use sharp or metal tools on a transducer face.*

---

- If the materials or type of unit prevents the use of a high-pressure hose, wipe the unit using a cloth dampened with water containing a little detergent.  
Examples:
  - The upper parts of hull units (inside the hull)
  - Hydraulic systems
- Do not use excessive amounts of water as some components on the unit may not be water tight. Wipe off the detergent with a damp cloth, then dry the unit thoroughly.
- All surfaces must be inspected for signs of corrosion, eg. flaking/bubbling paint, stains etc. Damaged or suspect areas must be cleaned, prepared and preserved using the correct preservation mediums. The mediums to be used will normally be defined in the unit's maintenance manual.

**Cables**

Wipe clean all exposed cables, and check for damage. If a cable shows signs of wear or ageing, contact Kongsberg Maritime for advice.

**Internal batteries**

If the unit contains batteries, these may discharge slowly during storage. If the unit is to be stored for an extended period, disconnect or remove all internal batteries.

A suitable piece of insulating material can be placed between the battery and the electrical contacts to prevent electrical discharge. The battery can then remain in the unit, reducing the risk of it being misplaced during the storage period.

---

*Caution*

*Units containing lithium or alkaline batteries must be handled separately and with care. Such units are marked accordingly. Do not attempt to recharge such batteries, open them or dispose of them by incineration. Refer to the applicable product data sheets.*

---

**Dehumidifier**

Place a suitably sized bag of desiccant material (silica gel or similar) into the unit to keep the electronic components as dry as possible.

**Coatings**

Spray the unit externally with a corrosion inhibitor (e.g. a light oil) before packing.

**Re-packing**

The unit should be stored and transported in its original packing material and/or crate. In the event that this material is not available, proceed as follows:

- Small units must be protected from damp by being placed within a plastic bag at least 0.15 mm thick. An appropriate quantity of desiccant material should be placed inside this bag, and the bag sealed. The sealed unit must then be placed in an appropriate carton or crate, and supported in the container by appropriate shock-absorbing insulation (polystyrene foam chips etc.).
- Large units must be placed in a suitable cardboard box or wooden crate. The unit must be protected against physical damage by means of shock-absorbing insulation mats. The box must be clearly marked with its contents, and must be stored in a dry and dust-free area.

**ESD precautions****Electrostatic Discharge (ESD)**

Electro-Static Discharge (ESD) is the transfer of an electrostatic charge between two bodies at different electrostatic potentials, caused either by direct contact or induction by an electrostatic field.

The passing of a charge through an electronic device can cause localised overheating, and it can also “puncture” insulating layers within the structure of the device. This may deposit a conductive residue of the vaporised metal on the device, and thus create a short circuit. This may result in a catastrophic failure, or degraded performance of the device.

**ESD Protection during transport and storage**

Sensitive electronic equipment must be transported and stored in protective packing bags, boxes and cabinets. The equipment must NOT be transported or stored close to strong electrostatic, electro-magnetic or radioactive fields.

### **Unpacking and servicing ESD sensitive equipment**

If it is necessary to open and touch the electronics inside the boxes/cabinets, then the following precautions **MUST** be taken:

- The working area must be covered by an approved conductive service mat that has a resistance of between 50k $\Omega$  and 2 M $\Omega$ , and is connected directly to a reliable earth point via its earthing cord.
  - The service personnel involved must wear a wrist-band in direct contact with the skin, connected to the service mat.
  - Printed circuit boards and other components should be placed on the conductive service mat during installation, maintenance etc.
- 

#### *Caution*

*If, for any reason, it is necessary to move the circuit board or components from the conductive service mat, they must be placed in an approved anti-static transportation container (e.g. static shielding bag) before transportation.*

---

- During installation and servicing, all electrical equipment (soldering irons, test equipment etc.) must be earthed.
- 

### **Temperature protection**

If the unit must be protected against extremes of temperature, the carton/crate must be lined on all walls, base and lid with 5 cm thick polyurethane or polystyrene foam.

These units will be identified as delicate in the applicable documentation.

---

The package must then be clearly marked:

#### Note

*Must not be transported or stored in temperatures below -5 degrees Celsius.*

---

Other units can normally be stored in temperatures between -30° C and +70° C, refer to the system's technical specifications for details.

Transducers must not be stored in temperatures below -20°C and above +60°C.



## 2 TECHNICAL SPECIFICATIONS

Note

---

*Kongsberg Maritime is engaged in continuous development of its products and reserves the right to alter specifications without prior notice.*

---

### Interfaces

- Serial lines with operator adjustable baud rate, parity, data length and stop bit length for:
  - Motion sensor (roll, pitch, heave and optionally heading) in format supported by sensors from Applanix, iXSEA, Kongsberg Seatex and VT TSS
  - Heading (gyrocompass) in either NMEA 0183 HDT, SKR82/LR60 or Sperry Mk39 format
  - Position in either Simrad 90, NMEA 0183 GGA or G GK format
  - External clock in NMEA 0183 ZDA format
  - Sound speed at transducer
  - Sea level height (tide)
  - Single beam echo sounder depths
  - Output of depth straight down in NMEA 0183 DPT format
- Interface for a 1PPS (pulse per second) clock synchronisation signal
- SCSI interface intended for tape drive
- Firewire interface for external data storage device (tape or disk)
- USB 2.0 interfaces for data storage, printing or plotting
- Parallel interface for PostScript colour graphics printer/plotter
- Ethernet interface for input of sound speed profile, tide and echo sounder depths, and output of all data normally logged to disk

## Physical specifications

### Transmit transducer

- **Width/diameter:** 114.3 mm
- **Height:** 73.2 mm
- **Length:** 419.1 mm
- **Weight:** Approximately 5 kg
- **Pressure rating:** 3000 m depth

### Sonar Head

- **Diameter:** 228 mm (without “ears”)
- **Height:** 238 mm
- **Weight:** Approximately 16.6 kg
- **Pressure rating:** 3000 m depth
- **Cable diameter:** 17 mm
- **Connector:** Seacon MING-10
- **Power:** +24 Vdc, 1.5 A (available from the Processing Unit)

### Processing Unit

- **Height:** 178 mm (excluding rack fixing brackets)
- **Width:** 448 mm
- **Depth:** 370 mm (excluding handles and connectors)
- **Weight:** 10 kg
- **Power:** 100 to 240 Vac, <100 W, 47 to 53 Hz

### Processing Unit for AUV

An optional external hard disk is not included.

- **Height:** 182 mm (including top cover)
- **Width:** 140 mm
- **Depth:** 421 mm (excluding handles and connectors)
- **Weight:** 4.5 kg
- **Power:** +24 Vdc, 29 VA and +5 Vdc, 33 VA
  - Note that these power measurements are for normal operations. Start-up values may be higher. The external power supply must be rated for higher, inrush current.

### HWS 10 Operator Station

**Height:** 127 mm

**Width:** 427 mm (excluding rack fixing brackets)

**Depth:** 480 mm (excluding handles and connectors)

**Weight:** 20 kg

**Power:** 115 Vac (60 Hz) and 230 Vac (50 Hz), < 250 W

**17.4" LCD monitor**

**Height:** 400 mm (excluding mounting bracket)

**Width:** 460 mm (excluding mounting bracket)

**Depth:** 71 mm (excluding mounting bracket)

**Weight:** 9.2 kg

**Power:** 115 Vac (60 Hz) and 230 Vac (50 Hz), < 60 W

**19" LCD monitor**

**Height:** 444 mm (excluding mounting bracket)

**Width:** 483 mm (excluding mounting bracket)

**Depth:** 68 mm (excluding mounting bracket)

**Weight:** 12 kg

**Power:** 115 Vac (60 Hz) and 230 Vac (50 Hz), 100 W (max)

**Environmental specifications**

Operating temperatures:

- Processing Unit: 0 to +45°C
- Operator Station: 0 to +45°C

Storage temperatures:

- Processing Unit: -30 to +70°C
- Operator Station: -30 to +70°C

Note

---

*Processing Unit specifications for both standard and AUV versions.*

---

## 3 OPERATOR STATION

### 3.1 Description and main functions

#### Introduction

The HWS 10 Hydrographic Work Station is the Operator Station normally used by the EM 2000.

#### Topic

→ *Theory, page 25*

→ *Installation, page 26*

## 3.2 Theory

### Overview

The HWS 10 is equipped to handle the heavy processing requirements and high-speed, large volume data storage demands of today's hydrographic systems. It has been specifically designed as the optimal platform for running the Seafloor Information System (SIS) real-time operating software used on the Kongsberg EM multibeam echo sounders. Special features of SIS include real-time:

- Gridding of sounding data.
- Filtering of sounding data.
- 3-D visualization of sounding data.
- Storage and visualization of high resolution backscatter data from the seabed and the water column.

### Software

The partitioned system disk is dual bootable with Linux® and Microsoft Windows XP® respectively. SIS software is factory installed and tested on both operating systems.

### Data storage

The primary task of the HWS 10 is to safeguard the collected data and to visualize it for quality control. All data is initially stored on a pair of high performance SerialATA disks. These disks are run in a RAID1 configuration, thus ensuring against loss of data even if one disk should fail. They are mounted in hot swappable enclosures, so that the collected data may be transported on the disk. A DVD recorder is the standard means for permanent archiving of the collected data. For users having preferences for other storage devices or media, the HWS 10 includes USB 2.0, Firewire (IEEE 1394) and SCSI interfaces. Gigabit Ethernet is available for transfer of the data to another network computer. For temporary storage data may also be backed up to the system drive.

### 3.3 Installation

The HWS 10 is prepared for mounting in a 19" rack. The system's 17.4" Industrial LCD monitor is also rack mountable, and a universal bracket is supplied for tabletop, overhead or bulkhead mounting. Both the workstation and the monitor are IP22 rated. A spill-proof US keyboard and a standard optical mouse is included, but a small IP65 keyboard with integrated track stick is optionally available. A 5.25" externally accessible drive bay is available for customer use. The system supports the use of a second LCD monitor, this may be a 15" unit for use as a helmsman display.

---

#### Note

*The IP22 rating requires that the two front USB ports (of a total of six) are covered. If the IP22 rating is not required, and the two front USB ports are needed, this cover may be removed.*

---

## 4 PROCESSING UNIT

### 4.1 Introduction

The EM 2000 Processing Unit performs the data acquisition, signal processing and function control.

#### Topics

→ *Processing Unit installation, page 28.*

#### Related topics

→ *Processing Unit outline dimension drawing, page 110.*

→ *AUV Processing Unit outline dimension drawing, page 112.*

## 4.2 Processing Unit Installation

### Description

---

Note

*Sometimes the EM 2000 system is delivered with an AUV Processing Unit instead of the standard Processing Unit.*

---

The Standard Processing Unit consists of an instrument case with integrated rack mounting ears for mounting in a 19 inch rack. Ventilation is through slits located on the front and rear and these should not be blocked.

### Location

It is recommended to place the Processing Unit in a room with environmental conditions similar to those required for extended human occupation. The physical location on the vessel should be decided by the cabling required. The main factor may be the length of the cable to the Sonar Head.

A 15 m long Sonar Head cable is normally delivered, but this length can be extended to 45 m. If the cable length allows it, the Processing Unit may be installed in the same room as the Operator Station.

### Installation

No specific installation procedures exist for the Processing Unit. However, you must install the unit so that it is properly physically supported and protected for shock, vibration and rough movements due to sea conditions. The Processing Unit may be installed in a 19" rack.

### Related topics

→ *For more information about recommended environmental conditions, refer to page 12.*



## 5 SONAR HEAD & TRANSMIT TRANSDUCER

### 5.1 Introduction

This chapter describes the installation of the EM 2000 Sonar Head and the Transmit Transducer. Their shape, outline dimensions and installation examples are shown in the figures.

#### Topics

- *General requirements, page 30*
- *Locating the units, page 32*
- *Sonar Head installation, page 36*

#### Related topics

- *Sonar Head, 150 degrees system, outline, page 106*
- *Sonar Head, 120 degrees system, outline, page 107*
- *Transmit Transducer, outline, page 108*

## 5.2 General requirements

The EM 2000 multibeam echo sounder is normally used for seabed mapping. The Transmit Transducer should then be aligned with the vessel keel, and mounted fairly horizontally looking downwards. A forward tilt of a few degrees is recommended as described below, but the amount of forward or sideways tilt is not critical.

---

### Note

*The Sonar Head should be mounted close to the Transmit Transducer. Especially if the minimum operating depth is small. (The receive beam must hit the transmit beam footprint).*

---

To find the front or face of the Sonar Head, you can see a small notch on the surface. You can also feel this notch if you move your finger over it.

Similar requirements are valid for the Transmit Transducer as for the Sonar Head. The two should be aligned with each other to get the best overlap of the transmit and receive beam footprints.

- Maximum difference in pitch:  $\pm 2.5$  degrees
- Maximum difference in heading:  $\pm 2.5$  degrees
- Maximum difference in roll:  $\pm 2.5$  degrees

The actual mounting angles and locations need to be known and entered into the Operator Station. A mounting frame with an acoustic window is available to allow the two to be mounted as a single unit and to give a streamlined configuration.

The curved receive transducer of the EM 2000 makes the system accuracy dependent of variations in sound speed at the transducer depth. It is therefore recommended to install a sensor to allow real-time measurement of this sound speed. The system will take into account the sensor measurements in its calculations of beam pointing angles and raybending. The system is prepared for using an AML Smart Probe directly. Due to possible marine growth, and to ease of cleaning or servicing of the sensor, it would be advisable to mount the sensor in a tank inside the hull, and pump water taken from the transducer depth through the tank on permanent installations.

The angles shown presume that the application is seabed mapping. However, the principles are readily applied to other applications.

Figure 3 Beam overlap

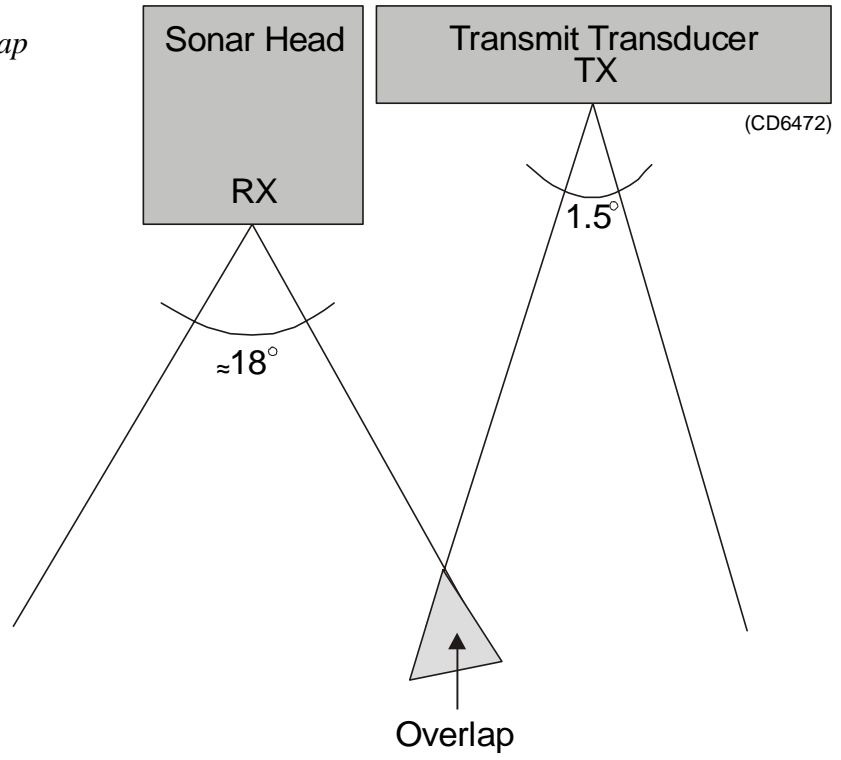

## 5.3 Locating the sonar heads

### General

Correct location of the system's Sonar Head and Transmit Transducer is vital for the operational performance.

A single answer to the question of where to locate the Sonar Head and Transmit Transducer cannot be given. It very much depends on the vessel's construction, and on whether the installation is permanent or not. However, there are some important guidelines which are generally applicable.

### The boundary water layer

The upper water layers of the sea contain a myriad of small air bubbles created by breaking waves. In heavy seas the uppermost 5-10 metres may be air-filled, with the highest concentrations near the surface. Air bubbles absorb and reflect sound waves, and may in the worst conditions block sound transmission totally.

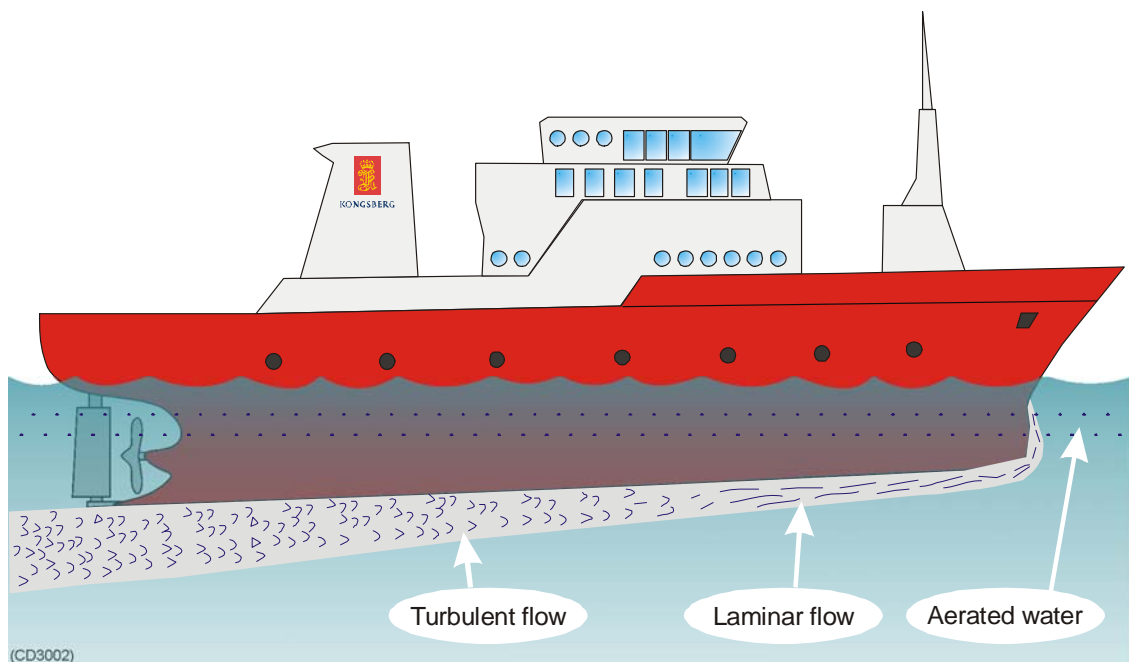

Figure 4 Sketch of boundary layer underneath the vessel

When a vessel moves through the sea, the friction between the hull and the water creates a boundary layer. The thickness of the boundary layer depends on the vessel speed and the roughness of its hull. Any objects protruding from the hull, and any dents in the hull, will disturb the flow and increase the thickness of the boundary layer. The flow in this boundary layer may be laminar or turbulent.

- A laminar flow is a nicely ordered, parallel movement of the water.
- A turbulent flow has a disorderly pattern, full of eddies.

The boundary layer increases in thickness when the flow goes from laminar to turbulent.

Furthermore, air bubbles in the sea water are pushed down below the hull and mixed into the boundary layer. The boundary layer is thin underneath the forward part of the vessel, and increases in thickness as it moves afterwards. If the sides of the hull are steep, some of the air bubbles in the boundary layer may escape to the sea surface along the vessel sides. It is our experience that a wide and flat bottom, with a rising angle less than about 13 degrees athwartship, is prone to cause air problems for a transducer.

The conclusion is that the Sonar Head and Transmit Transducer must be mounted as deep as possible, and in the forward part of the hull.

### **Propeller noise**

The propulsion propeller is the dominant noise source on most vessel types. The noise is transmitted through the sea water, and may in extreme cases reduce the maximum range capability of the EM 2000, despite its high sonar frequency.

Acoustic sensors must therefore be placed far away from the propeller, which means on the fore part of the hull. Positions outside the direct line of sight from the propeller are favourable. On small vessels with short distances it is advisable to mount the sensors on that side of the keel where the propeller blades move upwards. This is because the propeller cavitation is normally strongest on the other side.

When a bow thruster operates, the noise and cavitation bubbles from its propellers may make an echo sounder useless, almost no matter where its transducer is installed. Even when the bow thruster is switched off, its tunnel creates turbulence. If the vessel pitches heavily, the tunnel may be filled with air or aerated water in the upper position. This air or water is then released in the lower position.

For these reasons, the Sonar Head and Transmit Transducer must be placed well away from the bow thruster.

## Noise from protruding objects on the hull

Objects protruding from the hull, such as zinc anodes, sonar transducers or even the vessel's keel, generate turbulence and flow noise. Also holes and pipe outlets are noise sources. They may act as resonant cavities amplifying the flow noise at certain frequencies.

Due to this, the Sonar Head and Transmit Transducer must not be located in the vicinity of such objects, and especially not close behind them.

## Bulbous bow

If the vessel hull has a bulbous bow, this may well be a good location for acoustic sensors. However, also in this case the flow pattern of the aerated water must be taken into consideration. Often the foremost part of the bulb is preferable.

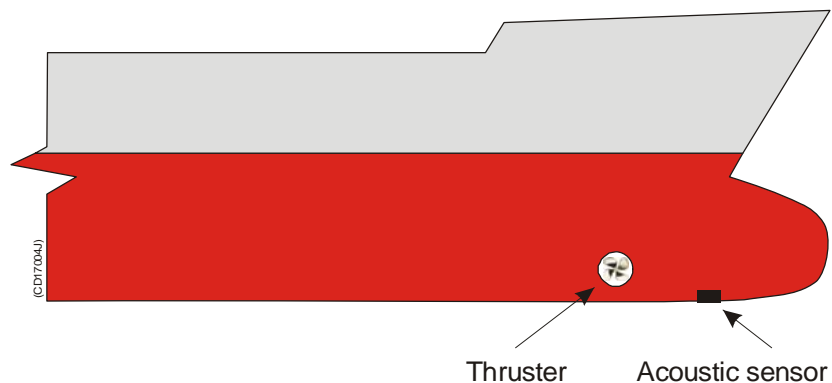

Figure 5 Acoustic sensor on a bulbous bow

## Summary

Some of the above guidelines may be conflicting, and each case has to be treated individually in order to find the best compromise.

In general, the possibility of getting air bubbles in front of the acoustic sensors is the most important factor, and thus the recommended location is in the fore part of the hull, with a maximum distance from the bow equal to one third of the total water line length of the hull.

If a nominal horizontal mounting of the Sonar Head is desired, its face should be tilted approximately  $3^\circ$  forwards, so that the flowing water meets it directly to assure a laminar water flow.



## 5.4 Installation

### Introduction

The EM 2000 consist of a Sonar Head and a Transmit Transducer. They must be installed close to each other.

The Sonar Head is a cylindrical-like container with the transducers located on one end. The cable connector and fastening holes are located on the side of the cylinder. The part with the transducers is the Sonar Head's "face". The area must have a free view of the bottom. Both ends of the head have index holes to assist in measuring the Sonar Head angular orientation, and the face has a forward indicator (the connector is at the forward part on the rear).

The Transmit Transducer is a long cylindrical-like container with a flat top. The transducers are located in the arch formed part of the container. This part must have free view of the bottom.

The Sonar Head is fastened with ten bolts with M8 thread. If access to the rear of the head to fasten these bolts is not possible, a **mounting ring** must be used as part of the mounting structure to allow fastening of the bolts from the front. This mounting ring must have an opening to allow clearance for the connector and cable, for example a hole with a diameter of 250 mm.

---

#### Note

*The risk of galvanic corrosion must be taken into account in the design of the mounting structure. Periodic inspection of the mounting screws and use of sacrificial anodes will be required in a permanent installation.*

---

#### Related topics

- *Sonar Head, 150 degrees system, outline, page 106*
- *Sonar Head, 120 degrees system, outline, page 107*
- *Transmit Transducer, outline, page 108*

### External mounting

The Sonar Head can be installed outside the hull, provided that the maximum vessel speed is not too high.



A fairing, made by the shipyard, may be placed between the Sonar Head and the hull, to adapt for the deadrise angle of the hull, or to achieve the desired mounting angle of the head. The fairing should have the same outline dimensions as the Sonar Head. A location approximately 0.5 m aside from the keel may be adequate for the passage of water between the keel and the transducer.

### **Keel mounting**

Vessels having a box keel may use this for Sonar Heads installation. The box keel is already the deepest part of the vessel. If the box keel is too narrow to accommodate the head, it can be widened, either symmetrically or to one side only. In the last case the installation could also be described as a blister merged into the keel.

### **Retractable hull unit mounting**

Retractable hull units are commonly used for horizontal looking sonars, but may also be utilized for the EM 2000 Sonar Head. The retractable hull unit is more expensive than a blister, but on vessels without a keel and with a wide, flat bottom for example, a retractable hull unit may be the only acceptable method for bringing the Sonar Head below the boundary layer. If a hull unit is already available on the vessel on which the Sonar Head is to be installed, it should definitely be considered.

### **Flush mounting**

Flush mounting may be used on very large vessels with a hull so deep that no air bubbles are found below the hull, and on vessels operating in shallow harbours or waters, where a protruding blister cannot be accepted.

The standard procedure for flush mounting on a steel vessel is to weld a steel tank inside the hull, and mount the Sonar Head into this tank. As for a blister, it is recommended to ensure that the interior of the tank is water filled. This can be accomplished by air release through a steel tube, which is extended either to open air above the water line or to the water outside the hull at a point higher than the tank interior. If the tube is extended to open air, drainage must be provided via a separate hole in the tank bottom.

## Preliminary mounting

The small size and weight of the EM 2000 system units makes the system truly portable. For temporary installations on a vessel the Sonar Head might be deployed through an existing gate valve on the vessel or on a pole fixed to the bow or on small vessels to the side.

The main consideration in such an installation is that the mounting structure is sufficiently rigid, i.e. dynamic displacements of the Sonar Head must be less than 2 cm and  $0.05^\circ$ , that the line of sight from the Sonar Head to the bottom is not blocked, and that aerated water is kept away from the Sonar Head face.

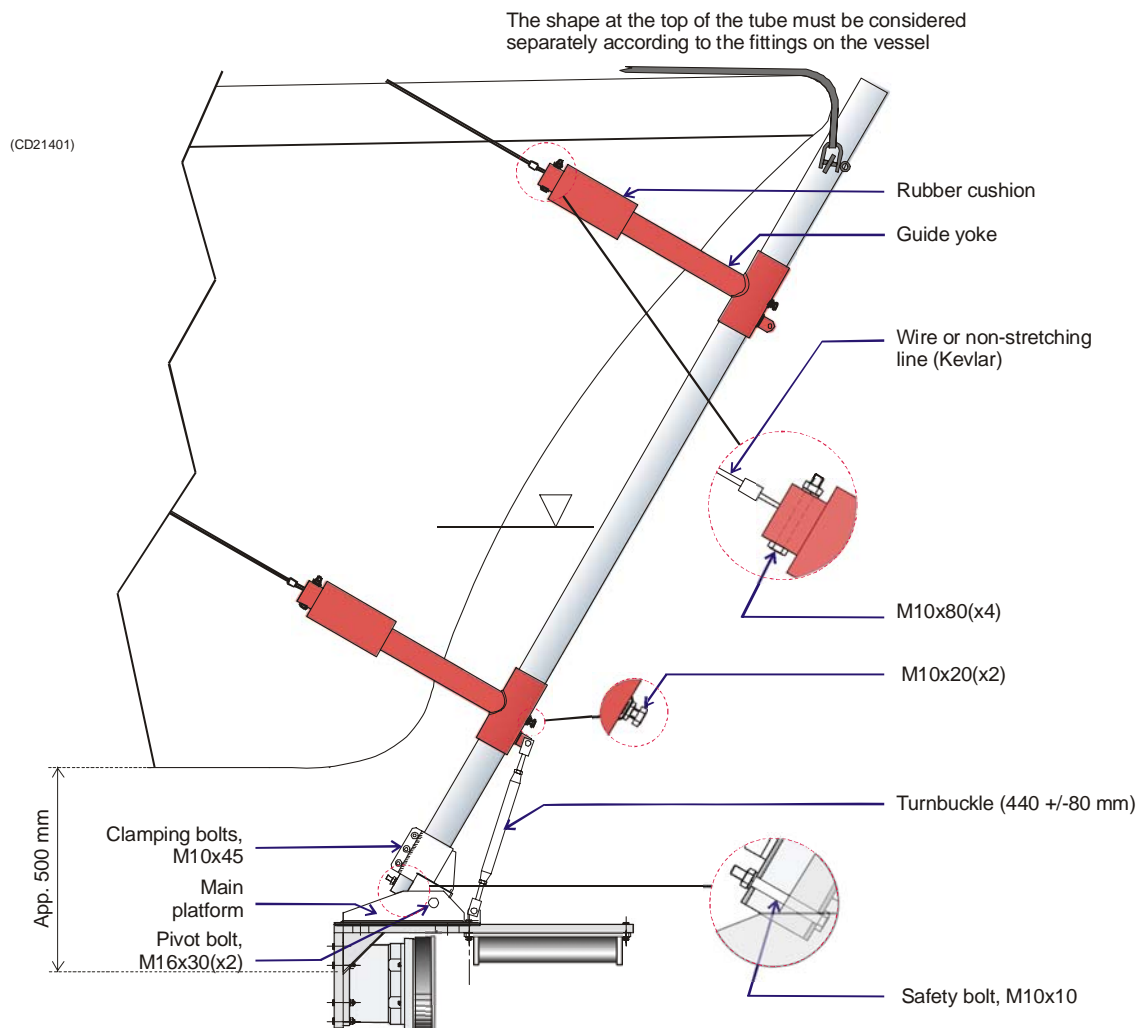

Figure 7 Bow mounting - example

Note

*When installing the system as shown on the previous illustrations, all nuts, bolts and washers must be manufactured of stainless steel (AISI 316). All bolts with lengths less than 30 mm must be fully threaded.*

---

## **Mounting on subsea vehicle**

The Sonar Head may be mounted on a subsea vehicle; ROV, AUV or towed body. The location on the vehicle must be such that the Sonar Head face has a free line of sight to the bottom, that the distance to noise sources such as thrusters is as large as possible, and that turbulent or aerated water from for example thrusters do not cross the face of the transducer during normal operation.

Note that the underwater vehicle must be properly instrumented with motion, heading and depth or pressure sensors.

The Sonar Head will also have to be locally supplied with power (+24 Vdc) and a suitable data communication link must be implemented to the surface. For most vehicles the Sonar Head will communicate with the Processing Unit placed on a surface vessel, while on an AUV the Processing Unit and an integrated local data storage system must be placed on the vehicle due to the lack of a communication cable.

## **Cabling**

It is recommended to lay a tube, preferably made of steel, from the Sonar Head to above the water line, and draw the Sonar Head cable through this tube. This will avoid the need for a watertight feed-through for the cable, and reduces the risk of problems due to noise and interference with other electrical equipment, especially if the steel tube goes all the way to the EM 2000 Processing Unit. Tube dimensions should be minimum 35 mm inner diameter and minimum 6 mm wall thickness (4.5 mm if galvanized). If the standard cable length of 15 m is too short, it is advisable to order a longer cable with the system. A too short cable may be extended with a separate cable, but only if proper connectors are used between them. A watertight feed-through is available from Kongsberg Maritime in case it is not possible to draw the cable through a tube above the water line.

## 6 SUBSEA VEHICLE INSTALLATION

### 6.1 Introduction

This chapter describes the installation of the EM 2000 in a subsea vehicle with practical solutions and considerations.

#### Topics

- *Principal solutions, page 41*
- *Processing Unit on the mother vessel, page 43*
- *Processing Unit on the subsea vehicle, page 47*

## 6.2 Principal solutions

The EM 2000 may just as well be used on a subsea vehicle as on a surface vessel. In principle the only difference is that an additional sensor is required to measure the vehicle's depth. However, there are a number of practical problems regarding the installation that must be resolved, and these may differ depending on the possibilities offered by particular vehicles. The primary question is where data from the external sensors are available. This decides where the Processing Unit is placed, and which data links are required between the vehicle and the mother vessel.

The vehicle must provide +24 Vdc with a current of at least 1 A. The head's position and angular orientation on the vehicle must be measured as on a surface vessel installation.

Power requirements: 24 Vdc, 29 VA and 5 Vdc, 33 VA.

---

### Note

*These power measurements are at normal operation. Startup values may be higher. The external power supply must be rated for higher, inrush current.*

---

On many subsea vehicles all relevant data regarding vehicle attitude and position (including vehicle depth) are available on the mother vessel, and the data quality may be sufficient for use with the EM 2000. The Processing Unit should then be installed on the mother vessel. This assumes that the data can be provided to the Processing Unit in an acceptable format, and that the tether or tow cable can provide the necessary data links between the Sonar Head and the Processing Unit.

The required data links are:

- one optical fibre providing a 110 Mbit/s data rate from the vehicle to the surface
- One bi-directional channel for an RS-485 serial line at 19200 baud.

The latter could either be provided through a spare twisted pair in the cable, or through a spare channel in the vehicle's multiplexing system via RS-232 converters.

Alternatively the Processing Unit could be installed in a pressure container and mounted on the vehicle. This requires interfacing to a motion sensor, heading sensor and depth sensor on the vehicle, and the vehicle's geographic position must be made available on the vehicle in real-time. A special AUV Processing Unit is developed for this purpose.

The data link between the vehicle and vessel required would in this case be:

- A bi-directional Ethernet with at least 10 Mbit/s data rate capacity
- A serial link for transferring the positioning data down to the Processing Unit.

The vehicle would have to provide power to the Processing Unit (about 50 W depending on voltage available) as well as power to the Sonar Head.

On an AUV the Processing Unit would also be mounted on the vehicle, but then together with an onboard data logging system. System control would be possible over a low speed acoustical data link. This alternative is not discussed further here, but Kongsberg Maritime can provide assistance in its implementation if required.

### 6.3 Processing Unit on the mother vessel

The Sonar Head cable provided with the EM 2000 can have a maximum length of 45 m. The length limitation is primarily due to the high speed data up-link. This data link is a so-called TAXI link using devices from AMD.

The signal is carried on the center conductors of two coaxial cables with ECL signal levels. An optical fibre must be provided for this link if the Processing Unit is placed in the mother vessel.

Kongsberg Maritime can deliver a fibre optic converter pair for this purpose. The cable has the following main specifications:

- It is intended for use with 62.5/125  $\mu\text{m}$  multi-mode fibre at a wavelength of 1300 nm.
- The allowed link loss over the fibre is 17.5 dB with these converters.
- The converter house dimensions are 36 x 100 x 150 mm including connectors and mounting flanges.
- The coaxial connectors are SMB towards the Sonar Head and Processing Unit (two on each side) using two 50 ohm coaxial cables, and ST (optionally FC) connectors for the fibre.

The two coaxial cables must have a length difference not exceeding 5 cm. Their maximum length is 45 m with RG/58 type cables, but any discontinuities (or use of thinner cables) will decrease this. Thus any cable discontinuities for example through underwater connectors must be as short and few as possible, otherwise the link may fail.

The converters require +24 Vdc power. The converter on the vehicle must be mounted in a housing with sufficient pressure rating. This could be the housing in which the tether or tow-cable is terminated. Alternatively a separate pressure bottle may be used. This can be supplied from Kongsberg Maritime.

The data from the tether or tow cable are usually taken through a winch with slip rings. Optical slip rings will usually give least problems, and allow mounting of the receive fibre optic converter close to the Processing Unit. With fibre optic slip rings you should be aware of the fact that the loss may vary between the slip rings, and that some of the slip rings may have an unacceptable high loss at some angles (and sooner or later the winch will be stopped at one of those angles).

If only electrical slip rings are available, the receive fibre optic converter must be mounted inside the winch. This requires that there are two 50 or 75 ohm coaxial slip rings available per head, and that they have sufficient communication bandwidth, say in the order of 150 MHz for taxi link use. As on the vehicle, the coaxial cables to the Processing Unit should not differ in length by more than 5 cm, and the maximum length should not be more than 25 m. However, this may be depending of the quality of the electrical slip rings. If longer lengths are required, a second optical fibre link on the vessel has to be employed.

---

Note

*On older installations, it was found that only about a meter of cable between receive fibre optic converter and Processing Unit was allowable. We believe this to be caused by the lack of dc blocking capacitors in the Processing Unit, and that the converter was not powered from the Processing Unit, thus causing dc offsets. On newer systems, the blocking capacitors are included on the BIFB board.*

---

The serial bi-directional link between the Sonar Head and Processing Unit is normally RS-485 at 19200 baud. If a shielded twisted pair is available for this link, it will suffice for lengths of at least up to 4000 feet. This is in accordance with RS-485 specifications, but longer lengths may be possible. If a separate twisted pair is not available for the serial link in the tether or tow cable, the link must be supported in some other way, usually through an existing multiplexing system via an optical fibre link. In this case it will usually be necessary to use RS-485 to RS-232 converters at both ends. The converters must support two-wire communication with automatic direction switching. Suitable converters are the ADAM-4520 RS-485/232 converters from Advantech with the converter switches set to 19200 baud, 10 bits and RTS control off.

---

Note

*It has been found that the use of such converters usually require pull-up and -down resistors being installed on the serial line both in the Sonar Head and in the Processing Unit. While current production systems have such resistors, older systems do not and may thus require retrofitting of such resistors to function with serial line converters.*

---

Note that the RS-485 signal levels must not be higher than 12 V or lower than -7 V with respect to a reference ground, otherwise the interface circuits may be damaged.



Special cables are required both on the vehicle and on the mother vessel. It is possible to cut a standard Sonar Head cable in two and add the required connectors to interface the user's equipment. However, as an underwater cable is not needed on the vessel side, it is probably better to not use the end of a standard cable there. You can then start with a new cable on the vehicle side. This is useful since the standard cable is needed if the system is not permanently deployed on a subsea vehicle, or for test purposes. Kongsberg Maritime will provide any assistance required for the manufacturing of the special cables.

The vehicle cable must have a **MING-10-CCP** connector at the Sonar Head side.

- The centre conductors of the coaxial cables connect to pins 4 and 5.
- The shields are both connected to pin 8.
- The two RS-485 conductors connect to pin 6 (A or data+) and 7 (B or data-) and their reference ground connects to pin 3.
- +24 Vdc is connected to pin 9, and the return to pins 1 and 2.

For cabling to the Processing Unit, the coaxial cables must be terminated in **Lemo FFA.1S.250.CTAC52Z-COMP** type connectors. It is important that the cables are not interchanged.

---

Note

*The center conductor of the cable connected to the connector identified with a red ring on the Processing Unit must end up at pin 1 on the Sonar Head connector when the connections to the fibre optic converters are identical.*

---

The RS-485 signal wires are to be connected to pin 3 (A or data+) and 4 (B or data-) on a **Lemo FGG.2B.306.CNAD99-COMP** type connector. Their reference ground connects to pin 2. +24 Vdc is available on pin 5 with return on pin 1 and 6 for the fibre optic converter. There is no need for two connectors with RS-485 signals when two heads are used.

It may in some cases be difficult to mount the fibre optic converter in an existing pressure housing on a subsea vehicle, thus requiring the use of a separate housing. Kongsberg Maritime has designed a suitable housing for this purpose. It has a diameter of 155 mm and a length of 275 mm excluding connectors, and may be used with both one or two converters.

All connectors are mounted at one end of the housing. The original design used circular Subconn neoprene connectors for electrical connections both to the Sonar Head (one or two 10 pin) and to the ROV (one 6 pin), and a Subconn hybrid connector for the fibre to the ROV (up to 4 fibers). Other connectors may be supplied upon request and Kongsberg Maritime may deliver all cables with a housing if required.

## 6.4 Processing Unit on the subsea vehicle

The solution with the Processing Unit on the ROV together with all necessary external sensors would probably lessen the required interaction between the ROV system and the EM 2000. However, it would increase the payload on the ROV, and a way must be found for transferring the ROV positions to the EM 2000 Processing Unit. The data link requirements would be less, and fibre optic converters for the Ethernet link are “of the shelf” items. Some engineering would be required with respect to connecting the EM 2000 to the telemetry system of the ROV. For operational procedures, refer to SIS Operator manual

### Standard Processing Unit

The circuit boards in the standard Processing Unit may be repackaged into a pressure bottle with a diameter of about 25-30 cm and a length of about 50-60 cm. Underwater connectors must be mounted on the bottle for connection to the Sonar Head, a motion sensor, a heading sensor, a depth sensor and for power and signal transfer to and from the ROV. The latter would need to provide power, a serial link for transfer of positioning data, and an Ethernet link to the Operator Station on the mother vessel.

### AUV Processing Unit

The AUV Processing Unit may be mounted into a pressure bottle with a diameter of about 25-30 cm and a length of about 50-60 cm. Underwater connectors must be mounted on the bottle for connection to the Sonar Head, a motion sensor, a heading sensor, a depth sensor and for power and signal transfer to and from the ROV. The latter would need to provide power, a serial link for transfer of positioning data, and an Ethernet link to the Operator Station on the mother vessel.

Suitable motion sensors are the **TSS DMS-05** and the **Seatex MRU 5** or **6**. Any high quality sub-sea gyrocompass may be utilized provided that it has a serial line output. A magnetic compass (included in the MRU 6) is usually not good enough, unless special post-processing is used to improve its accuracy. A Paroscientific Digiquarz pressure sensor is recommended for depth measurements. Note that the sensors may require separate serial line communication to the surface for setup and quality control, but possibly this is only required when the ROV is on deck. The sensors must of course all be mounted in pressure bottles.

Kongsberg Maritime will provide the Processing Unit in a pressure container if this is required.

## 7 EXTERNAL INTERFACES

### 7.1 Introduction

This chapter describes the signals used for optional external interfaces.

#### Topics

- *External synchronization, page 49*
- *1PPS, page 51*

## 7.2 External synchronization

The serial lines RTS (Request To Send) and CTS (Cleared To Send) signals are used for external synchronization. In addition a Trig out signal is issued by the BIF (Beamformer Interface) board.

Levels	
RTS, CTS = high	+3 to +15 V
RTS, CTS = low	-3 to -15 V
Trig out	TTL level

Outputs from PU	
Trig out = 1	TX is off (high TTL level)
Trig out = 0	TX is active (low TTL level)
RTS = high	PU is ready for a new ping
RTS = low	PU is not ready
RTS is pin 7	

Inputs to PU	
CTS = high	Ping command
CTS = low	Wait
CTS is pin 8	The CTS pulse length must be minimum 30 milliseconds
GND (ground) is pin 5	

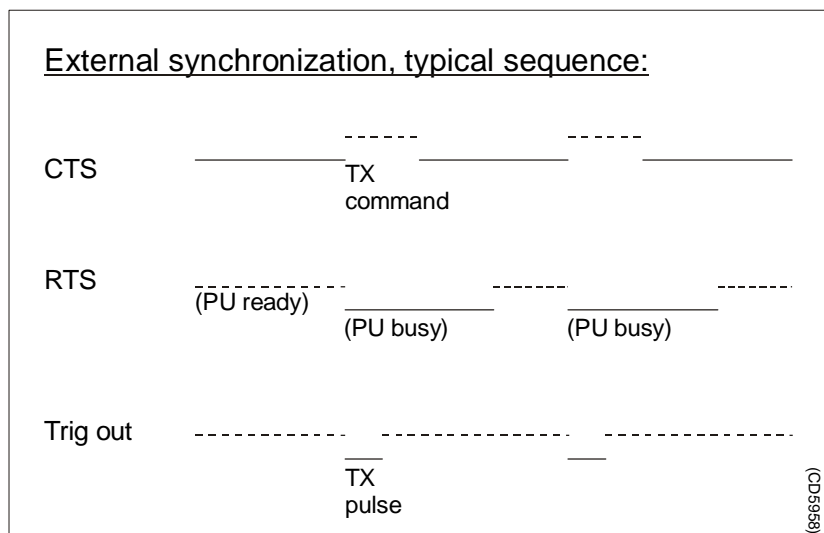

When the Processing Unit is ready for a new ping, RTS is set to high. When the external device is ready for a new ping, CTS is changed into high. The Processing Unit will then start a ping, change RTS to low (busy), and the Trig out will be low for 10 - 30  $\mu$ S, when the transmit pulse starts. After the Trig out is received, the external device should turn CTS to low, or at least keep it high for 30 milliseconds.

When the received period is finished and the Processing Unit is ready for a new ping, the RTS will be changed to high, and the Processing Unit will wait for a new trigger (a high level on CTS).

If CTS is high at all times, or if external synchronization in the installation menu is switched off, the Processing Unit will ping at its maximum rate.

### 7.3 1PPS

The 1PPS input signal is normally “resting” at a high level. Each second, a pulse (100 $\mu$ S-1000 $\mu$ S) adjusts the second counter in the Processing Unit. Since 1PPS is a TTL-signal, a high level at the input connector must be higher than 2,7 Vdc (margin is 0.3 Vdc) and a low level (during the pulse) must not exceed 0.6 Vdc (margin is 0.2 Vdc).

## 8 CABLE LAYOUT

### 8.1 Introduction

This chapter describes the standard cables used between the EM 2000 system units and between the units and their external devices.

---

Note

*All electronic installations and corresponding wiring must be in accordance with the vessel's national registry and corresponding maritime authority end/or classification society.*

---

If no such guidelines exist, Kongsberg Maritime AS recommends that Det norske Veritas (DNV) Report No. 80-P008 «Guidelines for Installation and Proposal for Test of Equipment» be used as a guide.

**Contact information:**

DNV  
Corporate Headquarters  
Veritasveien 1  
1322 Høvik  
Norway  
<http://www.dnv.com>

**Topics**

- *System cabling, page 53*
- *Cable plan - Operator Station, page 54*
- *Cable plan - Processing Unit, page 55*
- *Cable plan - AUV Processing Unit, page 56*
- *Cable specifications, page 57*
- *Sonar Head Connections, page 84*
- *Cable drawing list, page 62*
- *Cable drawings, page 63*
- *Basic cabling requirements, page 89*



## 8.2 System cabling

### Cable layout

Cables are identified according to individual cable numbers (Cxx), and references are made to dedicated cable drawings (Wxxx).

Cable information includes:

- Required specifications
- Equipment they are connected to
- Corresponding terminations

### System and shipyard cables

Cables fall into two categories:

- *System cables* supplied by Kongsberg Maritime with the EM 2000 system delivery.
- *Shipyard cables* provided by the shipyard performing the installation, or the shipowner. Cables to be provided by the installation shipyard are specified in the cable specifications. Note that the cable specifications provided are the *minimum acceptable*. Detailed cable information is provided for the:
  - Connection at each end (including reference to the corresponding: system unit, terminal board identification and plug/socket to be used).
  - Number of cores
  - Recommended type
  - Minimum specifications

---

Note

*Kongsberg Maritime accepts no responsibility for damage to the system or reduced operational performance caused by improper wiring.*

---

### 8.3 Cable plan

Each cable is identified with a cable identifier; Cxx. The notation Wxxx is the type/drawing reference number.

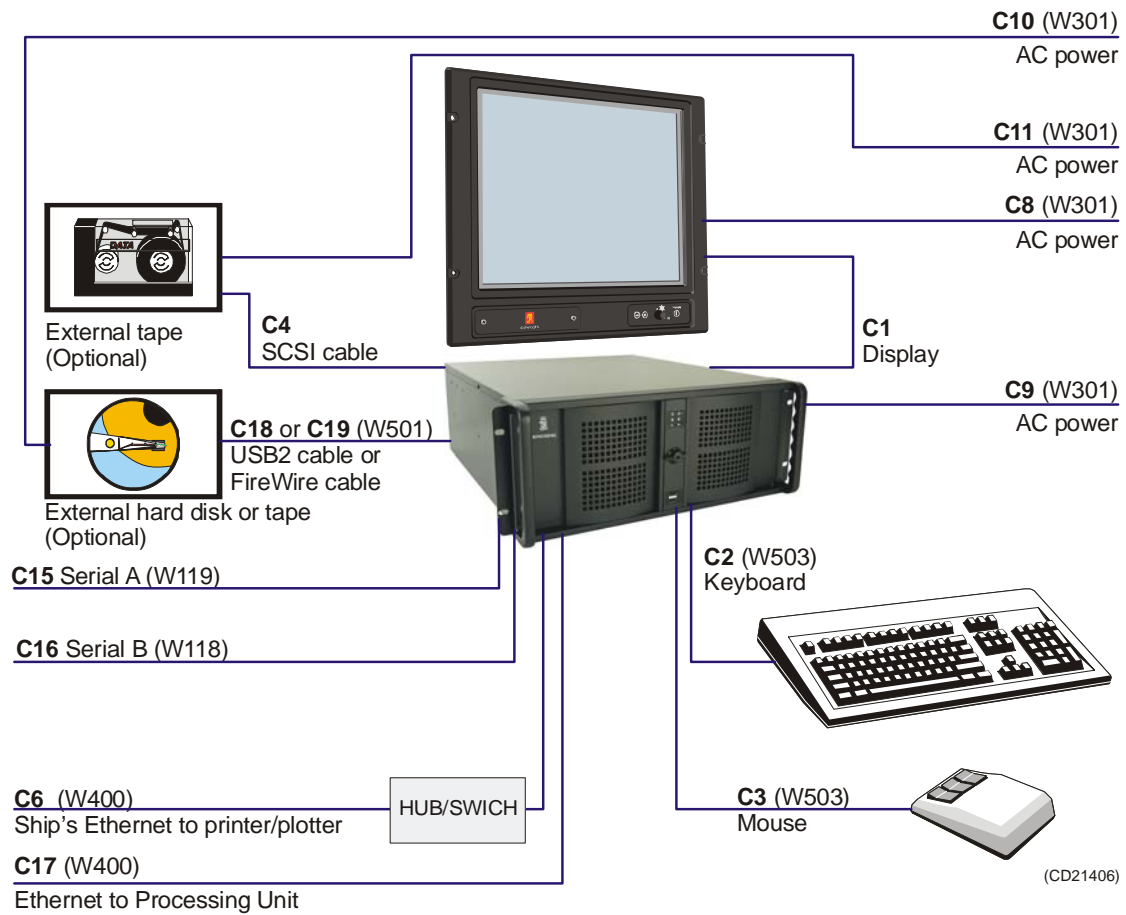

Figure 8 EM 2000 Cable plan - Operator Station.

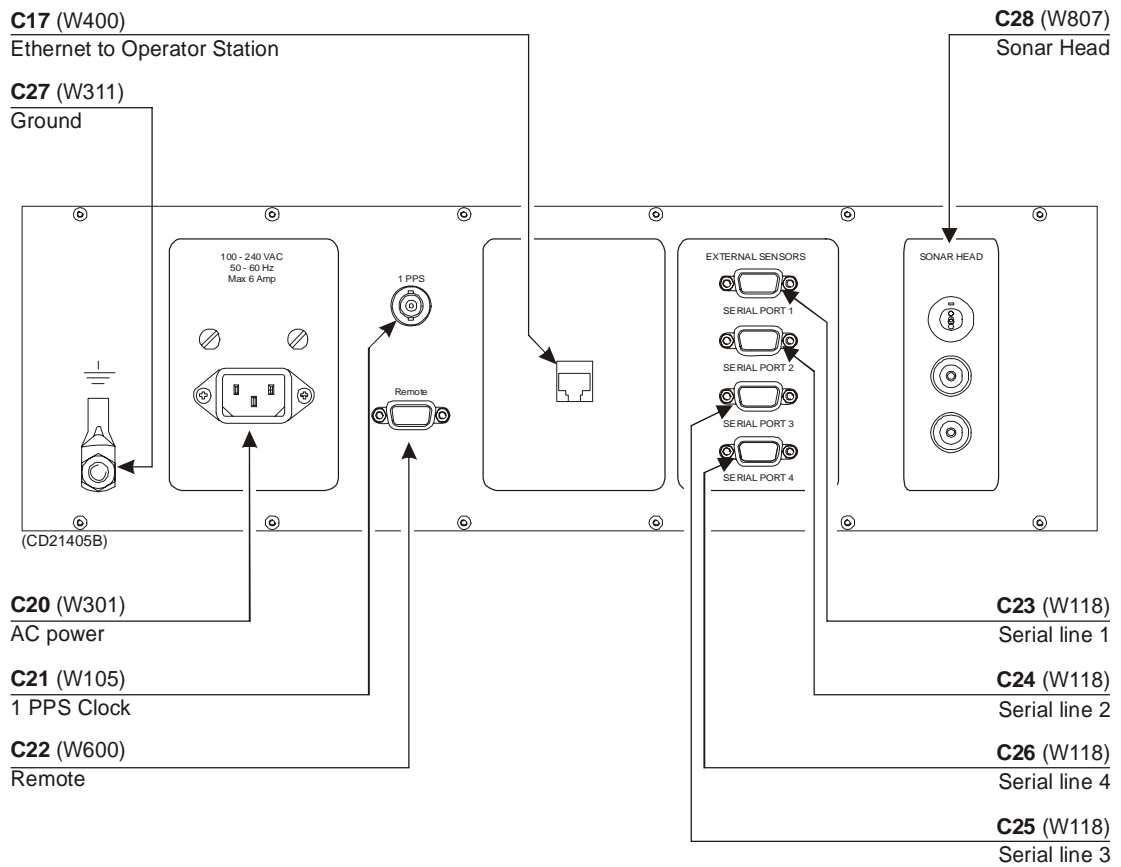

Figure 9 EM 2000 Cable plan - Processing Unit

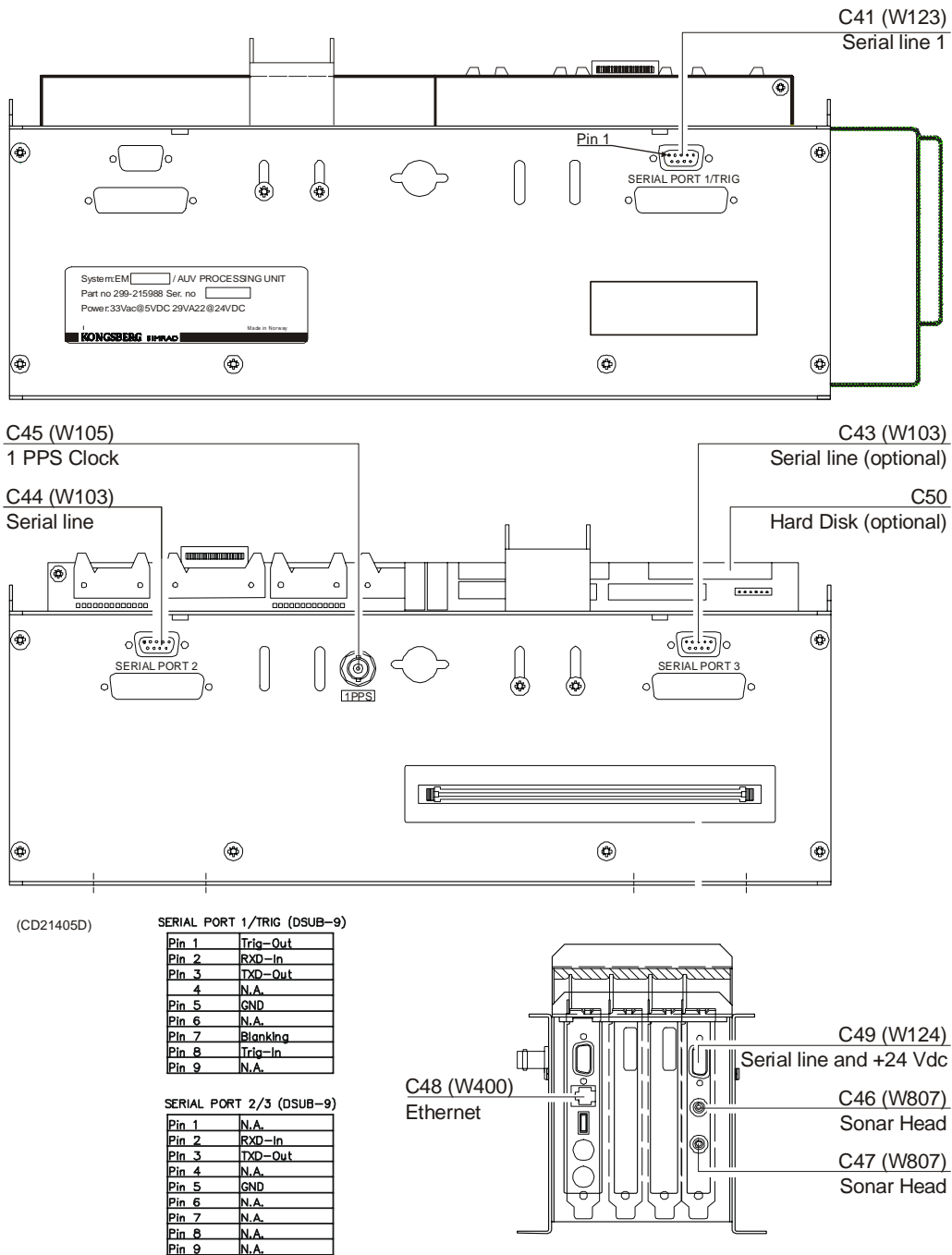

Figure 10 EM 2000 Cable plan - AUV Processing Unit

## 8.4 Cable specifications

Each cable is identified with a cable identifier; Cxx.

The termination of all the cables into plugs or terminal blocks are shown on the referenced pages.

### Operator Station cables

#### C1 Display monitor (video signal)

This is a standard display cable provided with the display. The physical properties of the cable is not specified in this documentation.

→ *Cable details on page 78*

#### C2 Keyboard

This is a standard keyboard cable provided with the keyboard. The physical properties of the cable is not specified in this documentation.

→ *Cable details on page 75*

#### C3 Mouse

This is a standard mouse cable provided with the mouse. The physical properties of the cable is not specified in this documentation.

→ *Cable details on page 76*

#### C4 SCSI external harddisk storage (optional)

This is a standard SCSI cable that can be provided with the Operator Station. The physical properties of the cable is not specified in this documentation.

#### C6 Printer/Plotter (optional)

This is a standard CAT-5 ethernet cable, and must be provided by the installation shipyard.

→ *Cable details on page 72*

#### C8 AC power display

This is a standard AC power cable. The physical properties of the cable is not specified in this documentation.

→ *Cable details on page 70*

**C9 AC power operator station**

This is a standard AC power cable. The physical properties of the cable is not specified in this documentation.

→ *Cable details on page 70*

**C10 AC power external tape storage**

This is a standard AC power cable. The physical properties of the cable is not specified in this documentation.

→ *Cable details on page 70*

**C11 power external harddisk storage**

This is a standard AC power cable. The physical properties of the cable is not specified in this documentation.

→ *Cable details on page 70*

**C15 Sound speed sensor**

Sound speed probe interface

→ *Cable details on page 66*

**C16 Depth/tide**

Generic RS-232 Serial line.

→ *Cable details on page 65*

**C17 Ethernet to Processing Unit**

This is a standard CAT-5 ethernet cable, and must be provided by the installation shipyard.

→ *Cable details on page 72*

**C5, 7, 12,13,14,18 and 19 not in use.**

---

**Note 1** - These are standard computer cables provided with the Operator Station. The physical properties of these cables are not specified in this documentation.

**Note 2** - W400 is a fixed length ethernet cable supplied with the system. If required, the cable can be extended.

**Note 3** - A synchronization system may be used when more than one echo sounder or sonar system are used simultaneously.

---

## **Processing Unit cables**

### **C17 Ethernet to Operator Station**

This is a standard CAT-5 ethernet cable, and must be provided by the installation shipyard.

→ *Cable details on page 72*

### **C20 AC power**

This is a standard AC power cable. The physical properties of the cable is not specified in this dokumentation.

→ *Cable details on page 70*

### **C21 1 PPS Clock**

Generic coax cable.

→ *Cable details on page 64*

### **C22 Remote**

Remote synchronization.79

→ *Cable details on page 79*

### **C23 Serial line 1**

Generic RS-232 with CTS and RTS

→ *Cable details on page 65*

### **C24 Serial line 2**

Generic RS-232 with CTS and RTS

→ *Cable details on page 65*

### **C25 Serial line 3**

Generic RS-232 with CTS and RTS

→ *Cable details on page 65*

### **C26 Serial line 4**

Generic RS-232 with CTS and RTS

→ *Cable details on page 65*

### **C27 Ground**

The physical properites of the cable is not specified in this dokumentation.

→ *Cable details on page 71*

### **C28 Sonar Head**

→ *Cable details on page 80*

### **C29 ... C40 not in use.**

## **AUV Unit Cables**

### **C41 / C43 / C44 - Serial lines**

The AUV Processing Unit is equipped with three RS-232 serial lines. All connectors are 9-pin male D-connectors.

Cable C41 is a serial line with trigger input.

→ *Cable details (C41) on page 67.*

→ *Cable details (C43, C44) on page 63.*

Some sensors may require RTS and CTS.

→ *Refer to the cable description on page 65.*

The cables must be provided by the installation shipyard.

### **C45 - 1PPS**

This is a timing signal terminated in a coax connector.

→ *Cable details on page 64.*

The cable must be provided by the installation shipyard.

### **C46 / C47 - Transducer cable to Sonar Head**

The standard Sonar Head cable delivered by Kongsberg Maritime has three plugs for connection to the standard Processing Unit. These plugs must be substituted by one underwater plug with minimum 10 pins.

A 4 meter cable without connectors in the “Processing Unit end” is available from Kongsberg Simrad.

This can be ordered on registration number:

- 380 - 212985.

#### Internal wiring inside the bottle

Cabling from the underwater plug to the AUV Processing Unit BIFB board:

- Two mini coax cables must be used for the TAXI high speed up-link.
- A multi wire cable must be used to connect 24 V, RS-485 serial line.

Plug and cable specifications (not supplied by Kongsberg Maritime):

- 2 mini coax connectors to plug into the BIFB board.
- 2 mini coax cable for the TAXI link.



- Plug for power and serial link for connection to the BIFB board: standard 9 pins delta plug.
    - Minimums cable dimensions: 0.5 mm<sup>2</sup>.
- *Cable details on page 69.*

#### **C48 - AUV Processing Unit RJ-45 interface**

Refer to the Operator Station cabling.

#### **C49 - Serial line and power**

The AUV Processing Unit is equipped with one RS-485 serial line with +24 Vdc power input. The connector is a 9-pin male D-connector.

→ *Cable details on page 68.*

#### **C50 - Hard disk (optional)**

This is a standard hard disk cable. The physical properties of these cables are not specified in this documentation.

#### **Power cables**

The AUV Processing Unit uses +5 Vdc and +24 Vdc for the Sonar Head. These cables are delivered without connectors.

100 cm cables are supplied by Kongsberg Maritime. They should be shortened as much as possible to minimize voltage drop.

The power cables are brown for +5 V and red for +24 V. Both use black as ground.

The 5 V ground and the 24 V ground must be connected together externally.

Power requirements: 24 Vdc, 29 VA and 5Vdc, 33 VA.

---

#### Note

*The 5 V power measured at the motherboard terminals should be minimum 5.0 Vdc. The 5 V power should be rated for minimum 12 A and 24 V power should be rated for minimum 1.5 A.*

---

## 8.5 Cable drawing list

- *W103 - Generic RS-232 Serial line, page 63*
- *W105 - Generic coax cable, page 64*
- *W118 - Generic RS-232 with CTS and RTS, page 65*
- *W119 - Sound speed probe interface, page 66*
- *W123 - RS-232 Serial line with Trigger signals, page 67*
- *W124 - RS-485 Serial line and power, page 68*
- *W125 - Mini Coax, page 69*
- *W301 - Standard AC power cable, page 70*
- *W311 - EMC ground, page 71*
- *W400 - Ethernet with RJ45 plugs (screened), page 72*
- *W404- Ethernet with IEEE 802.3, page 73*
- *W501 - Standard USB cable, page 74*
- *W503 - Keyboard cable, page 75*
- *W504 - Mouse or pointing device cable, page 76*
- *W505 - Printer cable, page 77*
- *W508 - Digital Video Interface (DVI) display cable, page 78*
- *W600 - Remote synchronization, page 79*
- *W807 - Sonar Head cable, page 80*
- *Sonar Head cable drawings, page 81*

### Generic RS-232 Serial line

This cable comprises a multi-purpose serial line. It provides interface with any peripheral unit. One end of the cable connects to the local unit (DTE) with a 9-pin 'D' connector, while the other connects to the peripheral (DCE) as described in the peripheral unit's documentation.

Note that this cable does not support all the signals in the standard RS-232 specification.

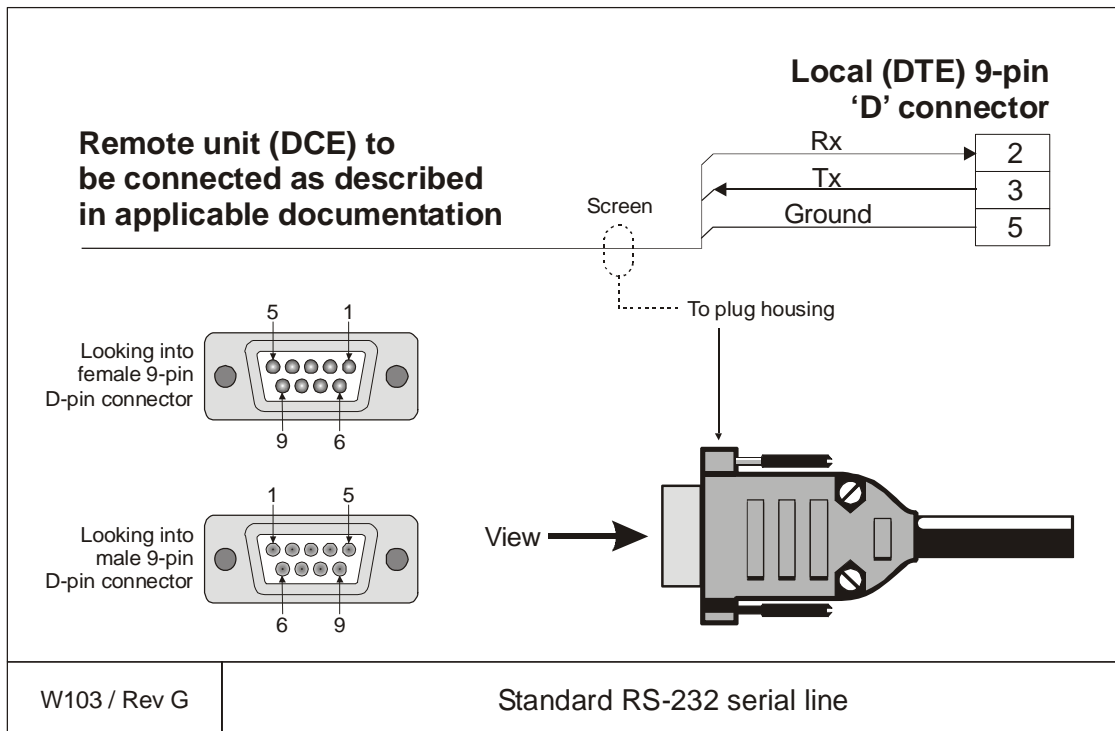

Conductors	3 x 2 x 0.5 mm <sup>2</sup>
Screen	Overall braided
Voltage	60V
Max.diameter	Set by the plugs

### Generic coax cable

This cable is used for connections to peripheral units or networks.

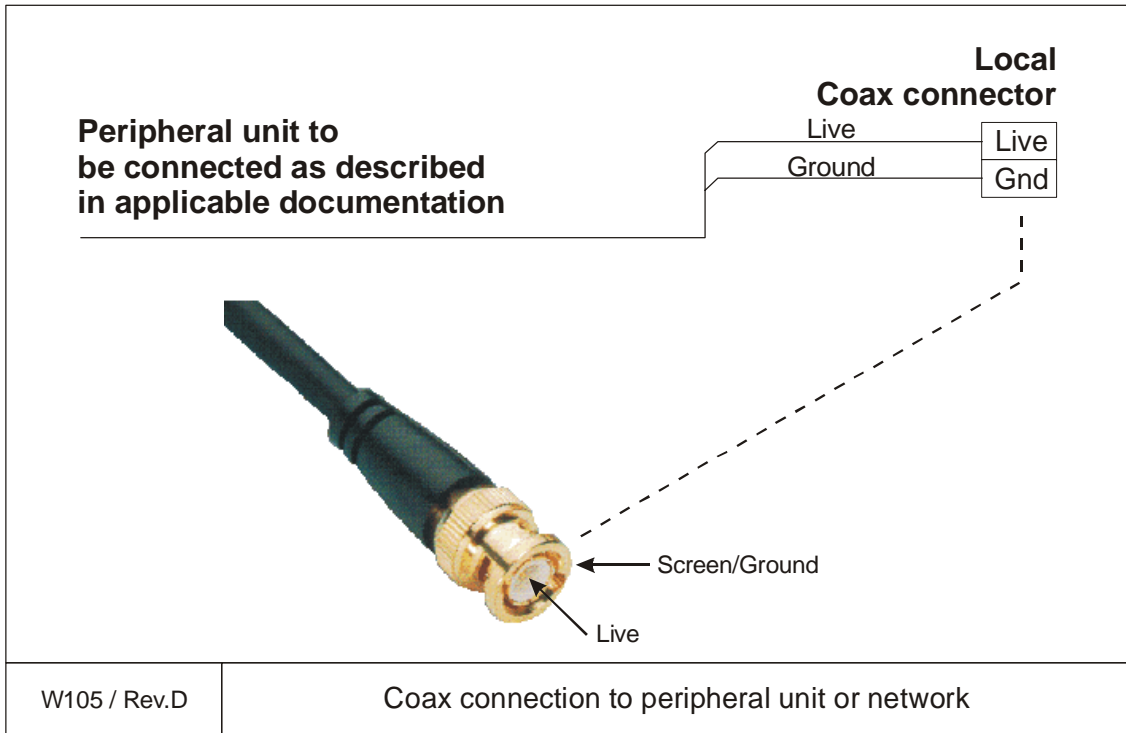

### Generic RS-232 with CTS and RTS

This is a standard serial cable terminated into a 9-pin D-connector.

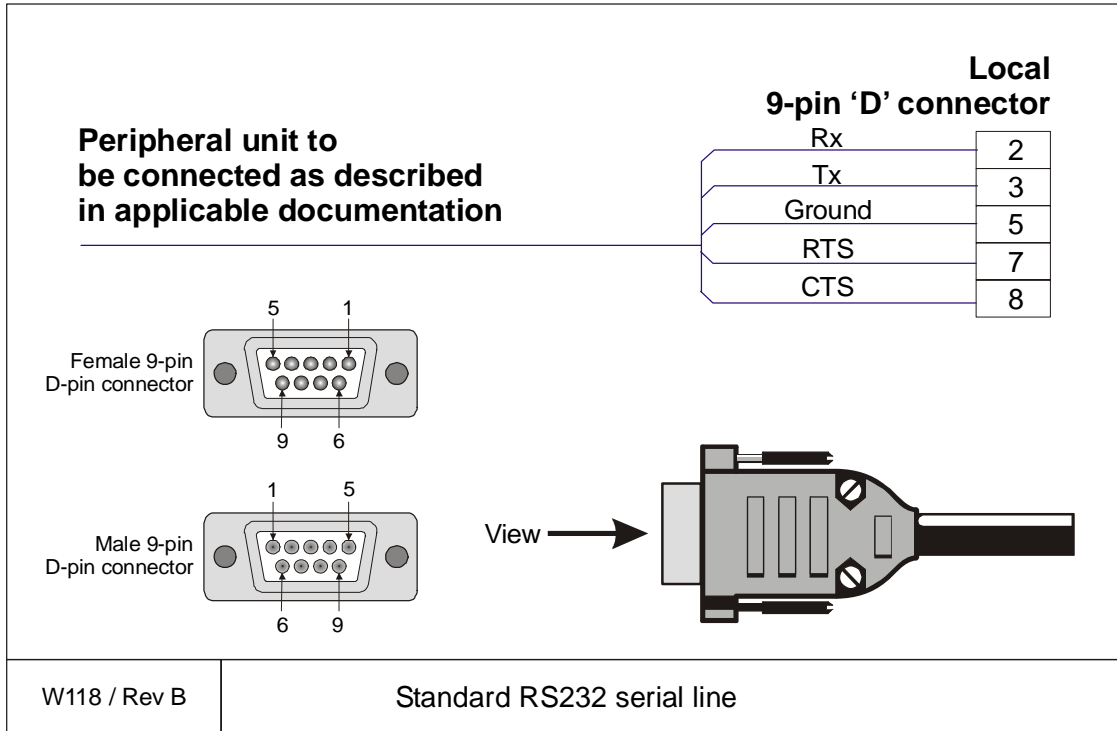

Conductors	6 x 0.5 mm <sup>2</sup>
Screen	Overall braided
Voltage	60 V
Max.diameter	Limited by the plugs

### Sound speed probe interface

This cable provides the interconnection between the Processor Unit work station and the sound speed probe. This connection is normally made through a small junction box and with a power supply as indicated in the drawing.

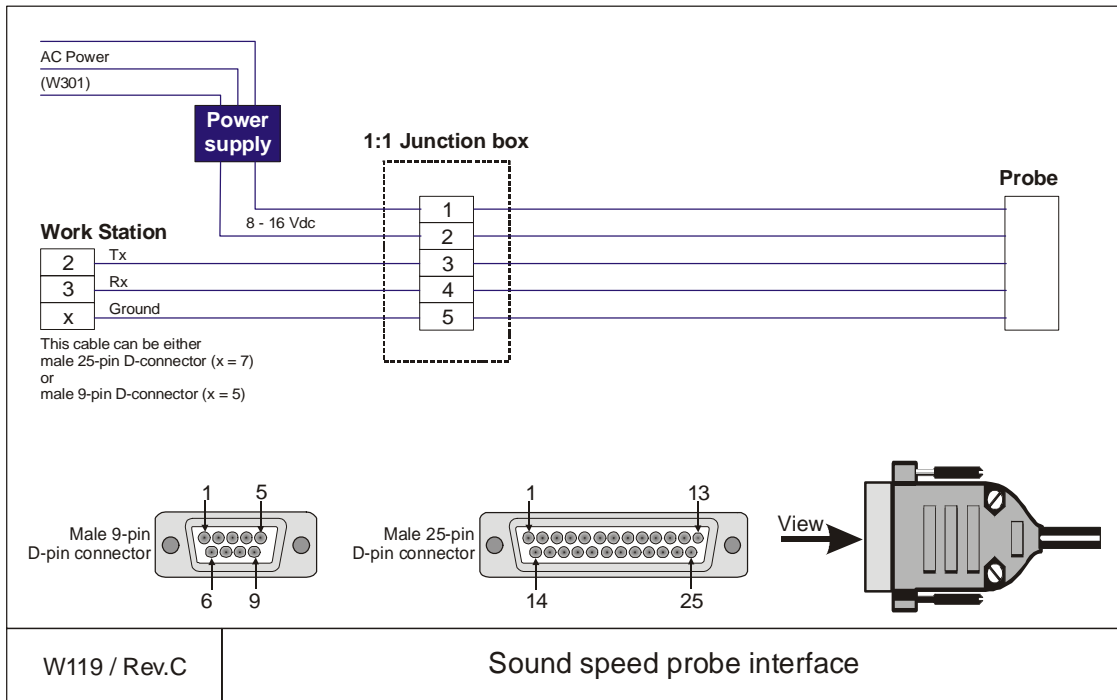

The cable between the junction box and the probe is supplied by the probe manufacturer.

Conductors	2 x 2 x 0.5 mm <sup>2</sup>
Screen	Overall braided
Voltage	60V
Max.diameter	Set by the plugs

## RS-232 Serial line with Trigger signals

This cable is used by the AUV Processing Unit.

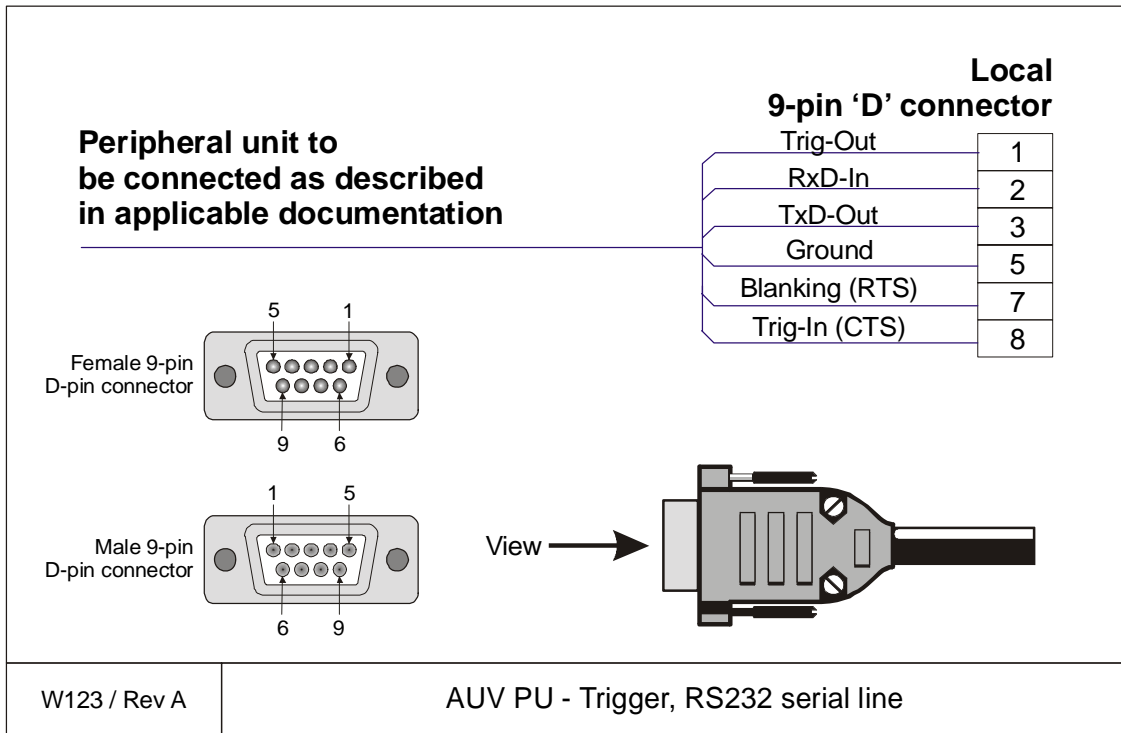

Conductors	6 x 0.5 mm <sup>2</sup>
Screen	Overall braided
Voltage	60 V
Max.diameter	Limited by the plugs

## RS-485 Serial line and power

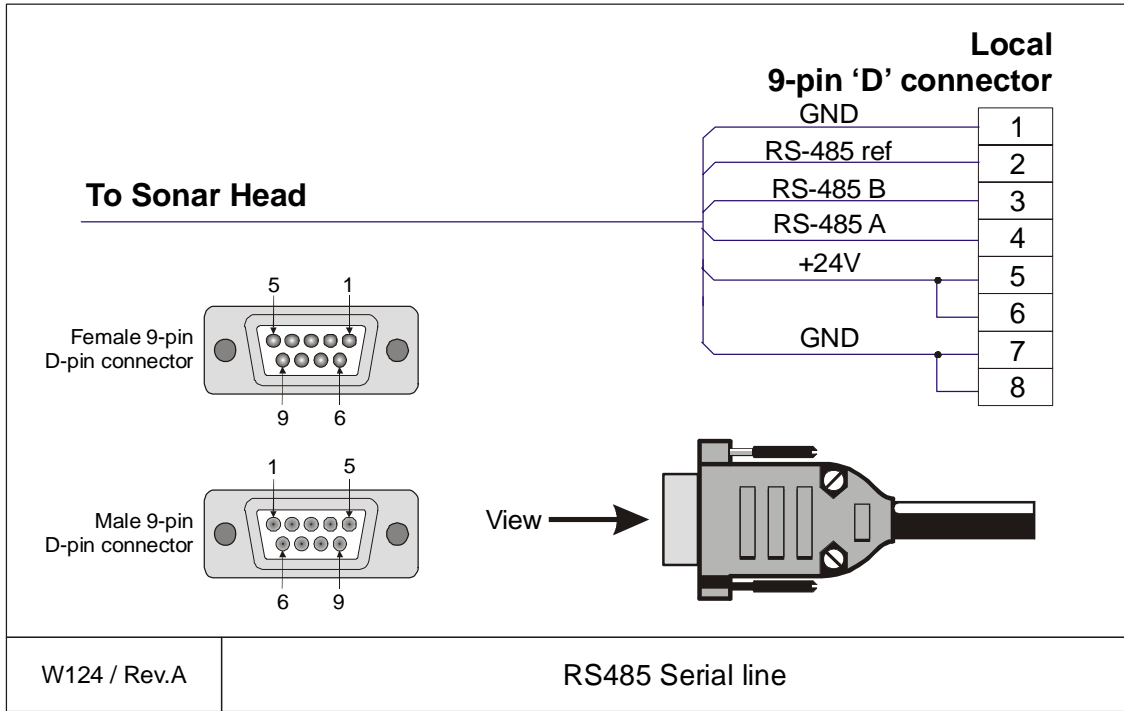

Conductors	6 x 0.5 mm <sup>2</sup>
Voltage	60 V



### Mini Coax

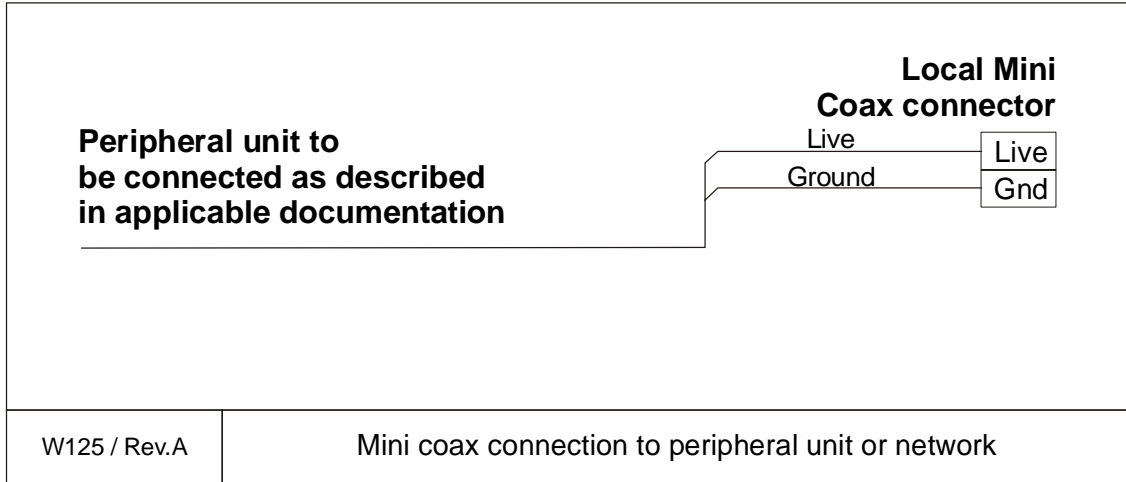

## Standard AC power cable

This cable is a standard three-wire power cable. It is commercially available in standard lengths, or may be produced locally to suit the specific installation needs. The instrument end is terminated in a standard IEC female socket, while the other end is terminated in a plug suitable for the local standard.

### Pin configuration

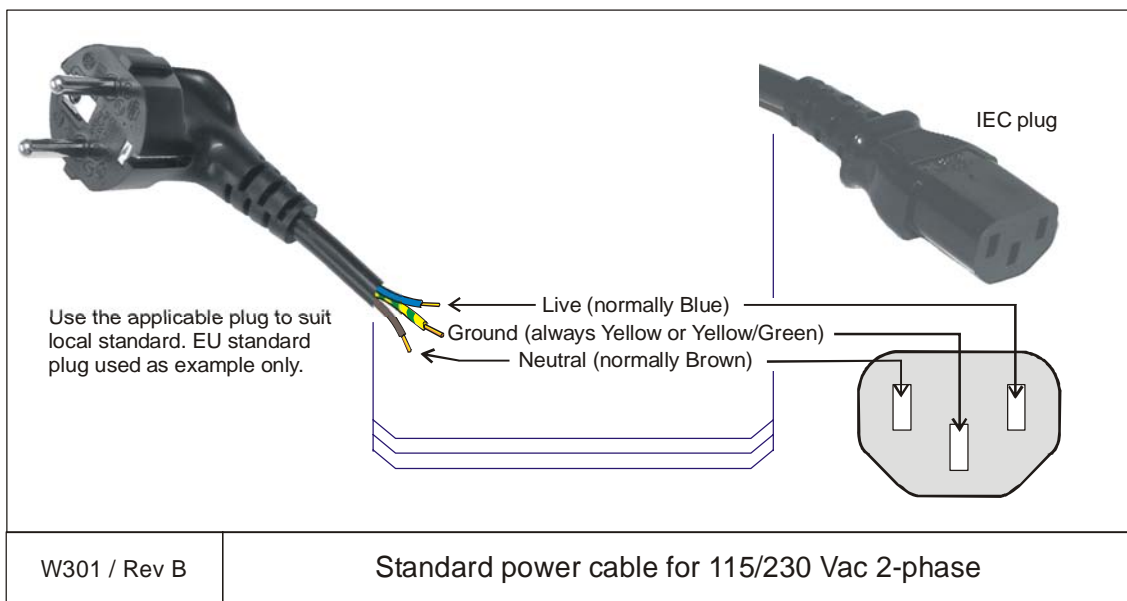

### Note

*Different cable colours may be used for the “live” and “neutral” wires. Ground is however always on green/yellow.*

### Specifications

Conductors	2 x 1.5 mm <sup>2</sup> + GND
Screen	None
Voltage	750 V
Max. diameter	Set by the plugs

### EMC ground

This cable is used to connect the system unit to the ship's ground.

Note that this cable must be as short as possible.

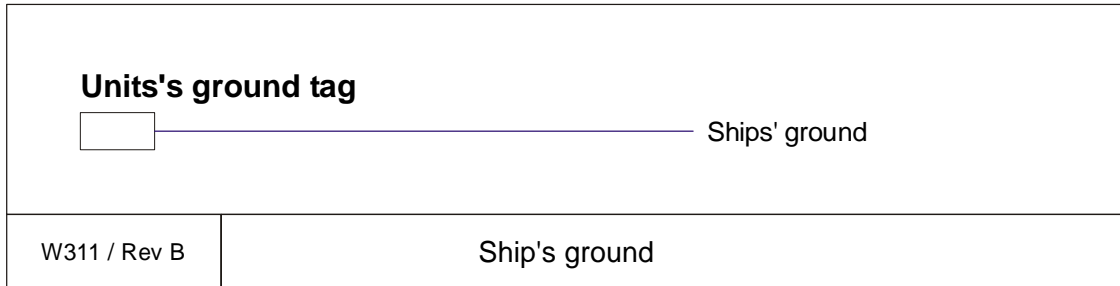

Minimum cable specifications	
Conductors	1 x 6 mm <sup>2</sup>
Screen	None
Voltage	60 V
Max.diameter	N/A

## Ethernet with RJ45 plugs (screened)

This cable contains the Ethernet connection. RJ45 plugs are used to terminate the cable. Note that these plugs must be screened to comply to EC rules.

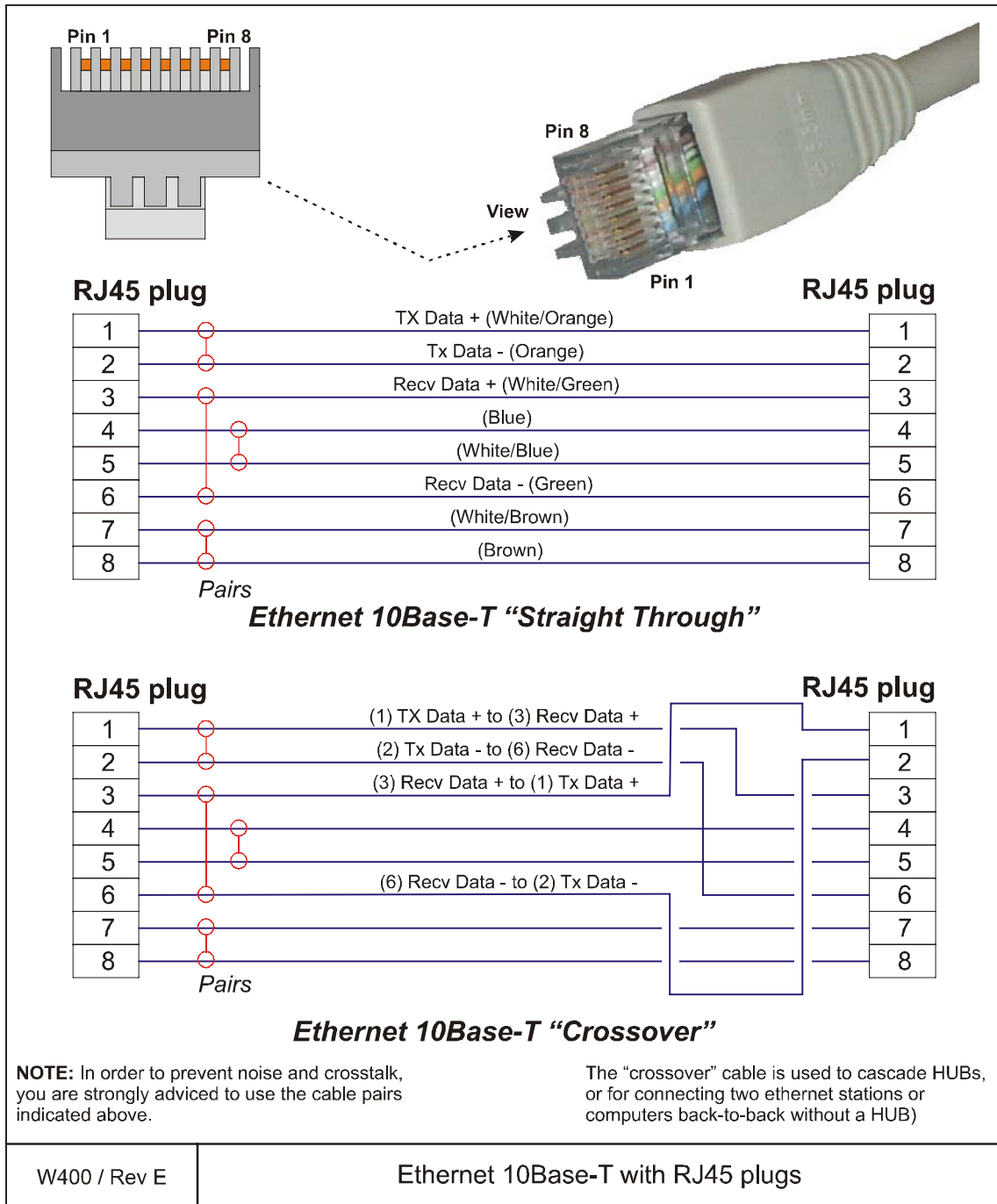

### Ethernet with IEEE 802.3

This is a standard ethernet connection. It complies to IEEE 802.3.

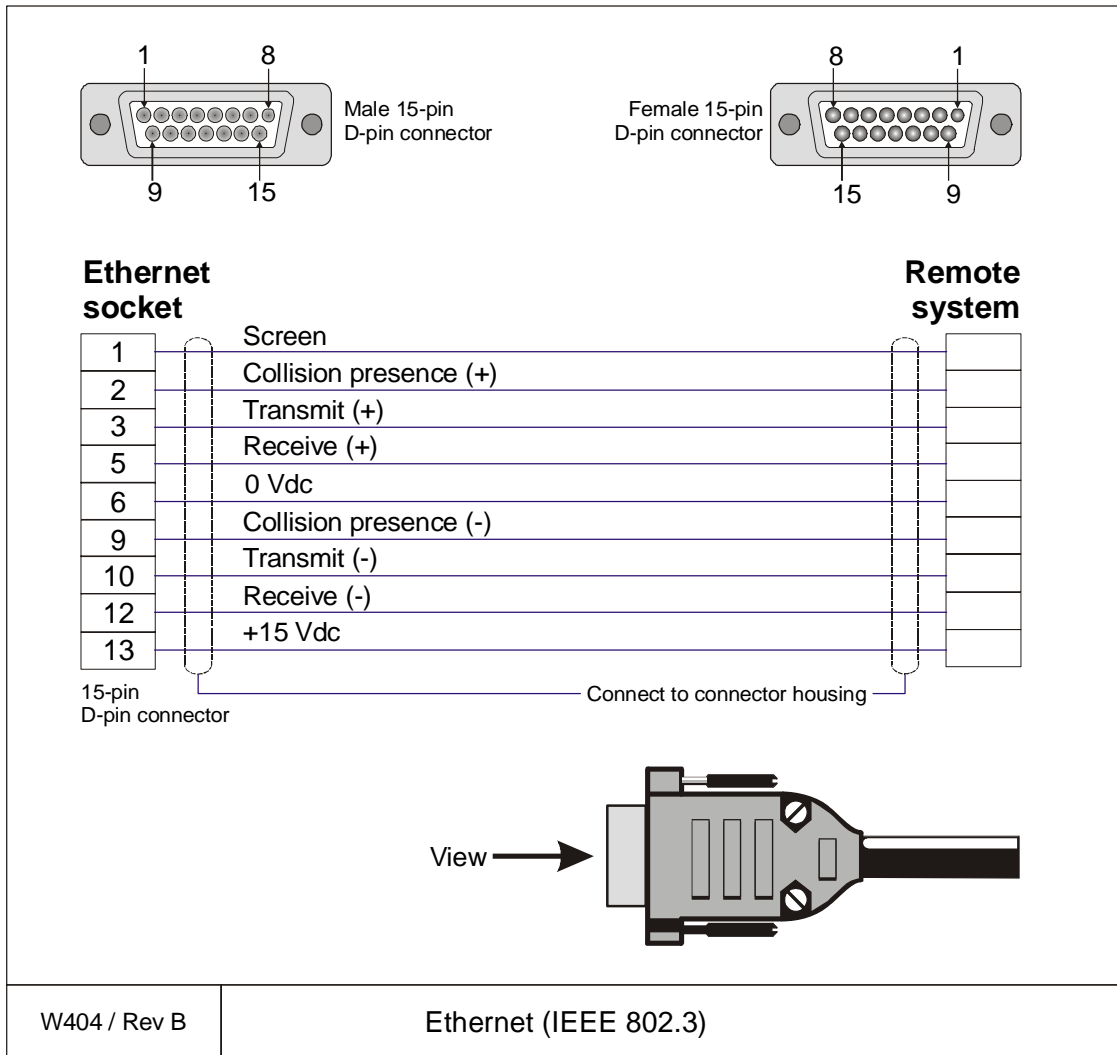

Conductors	6 x 0.5 mm <sup>2</sup>
Screen	Overall braided
Voltage	60 V
Max.diameter	Limited by the plugs

### Standard USB cable

This is a standard commercial USB cable terminated with **A** and **B** plugs in either ends. The cable can be used for a variety of external devices. The order number provided is for a 4.5 m cable.

Universal Serial Bus (USB) cable terminated with an **A-plug** in one end and a **B-plug** in the other.

Internal cables:

**Pair 1:**  
28 AWG twisted pair  
(data, green, white)

**Pair 2:**  
20 AWG twisted pair  
(Power, red, black)

**Shield:**  
Foil and braid

Length: 4.5 m  
Order no: 719-078524

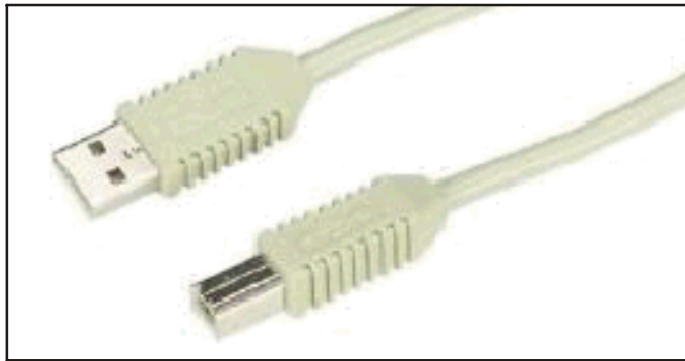

W501 / Rev.A

Commercial USB cable

## Keyboard cable

This is a standard keyboard cable. In most cases, the cable is physically connected to the keyboard. It is terminated in a plug suited to fit the computer.

Several keyboard types are available for different languages and hardware platforms. Both the keyboard and the attached cable are commercial items.

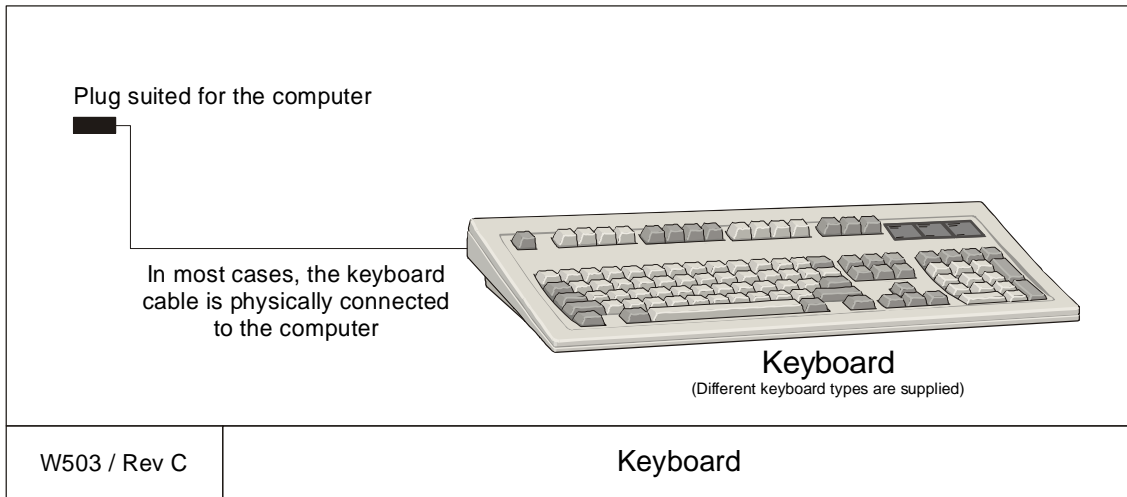

### Mouse or pointing device cable

This is a standard mouse cable. It is physically connected to the mouse. It is terminated in a plug suited to fit the computer.

---

**Note**

*On Unix work stations, the mouse is normally connected to the keyboard.*

---

Several mouse and pointing device types are available with two or three buttons, and with or without a scroll wheel. Both the mouse and the attached cable are commercial items.

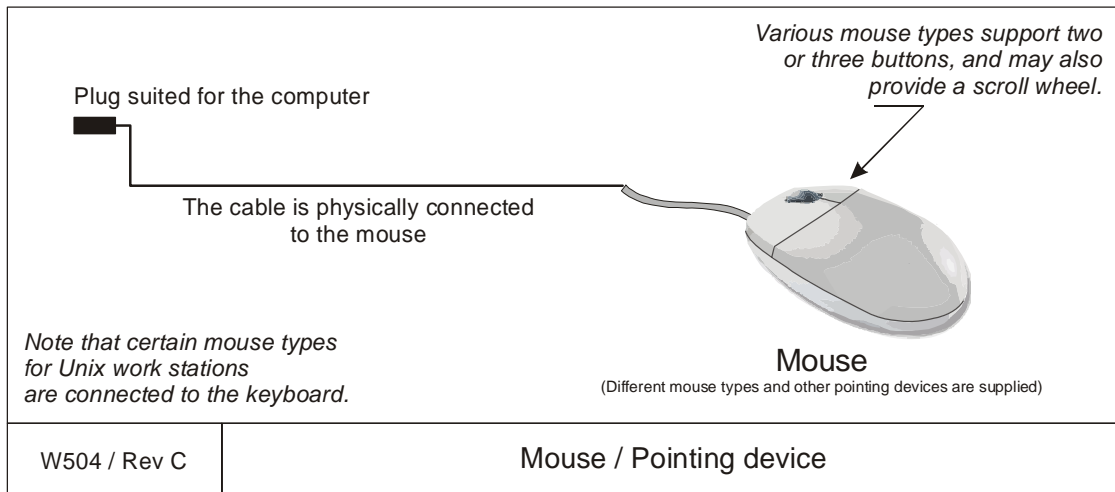



## Printer cable

This is a standard printer cable. It is terminated in the computer's parallel port.

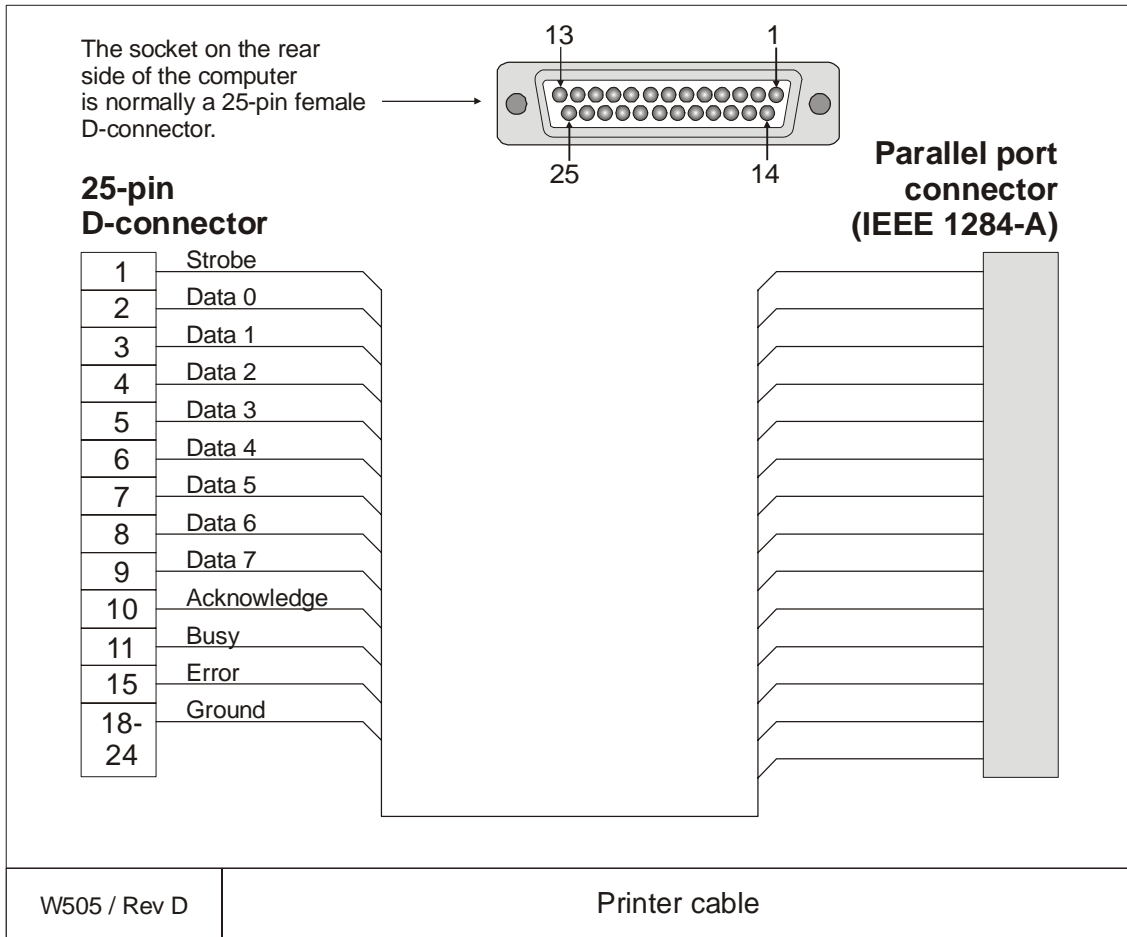

### Digital Video Interface (DVI) display cable

This cable is a standard DVI-I cable. It is connected to the LCD display.

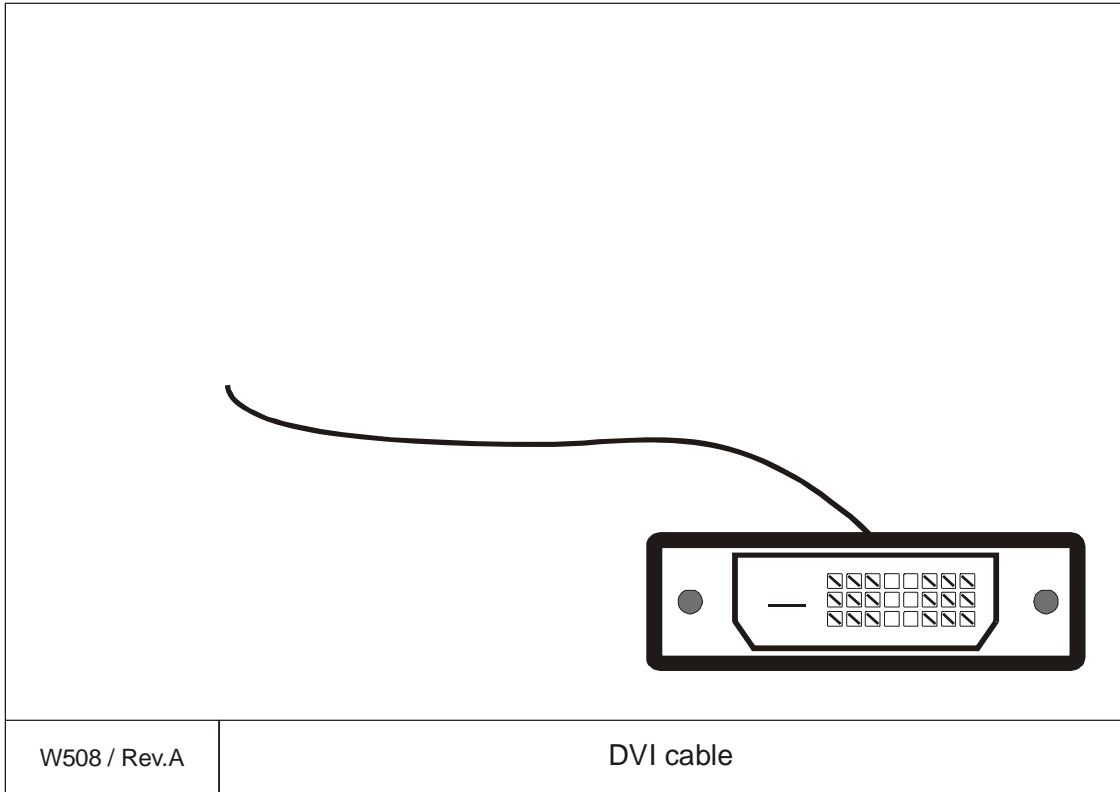

## W600 - Remote synchronization

The cable is supplied by the manufacturer.

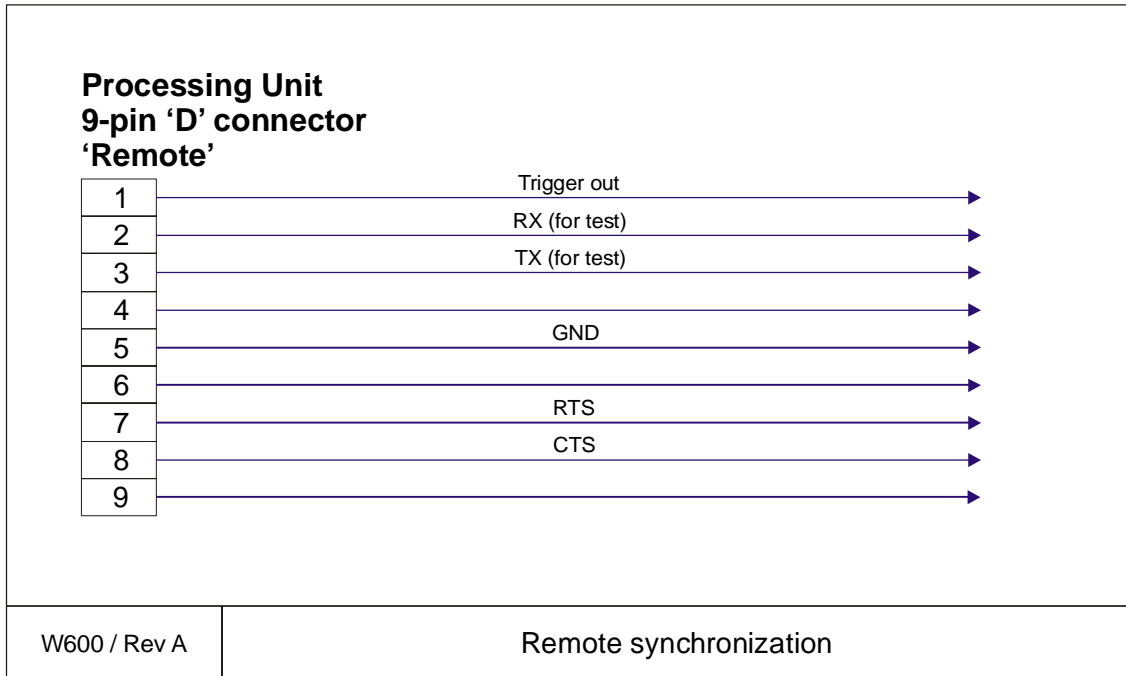

Conductors	5 x 2 x 0.5 mm <sup>2</sup>
Screen	Overall braided
Voltage	60 V
Max.diameter	Limited by the plugs

### W807 - Sonar Head cable

This is the cable from the EM 2000 Processing Unit to the Sonar Head. The cable is supplied by the manufacturer.

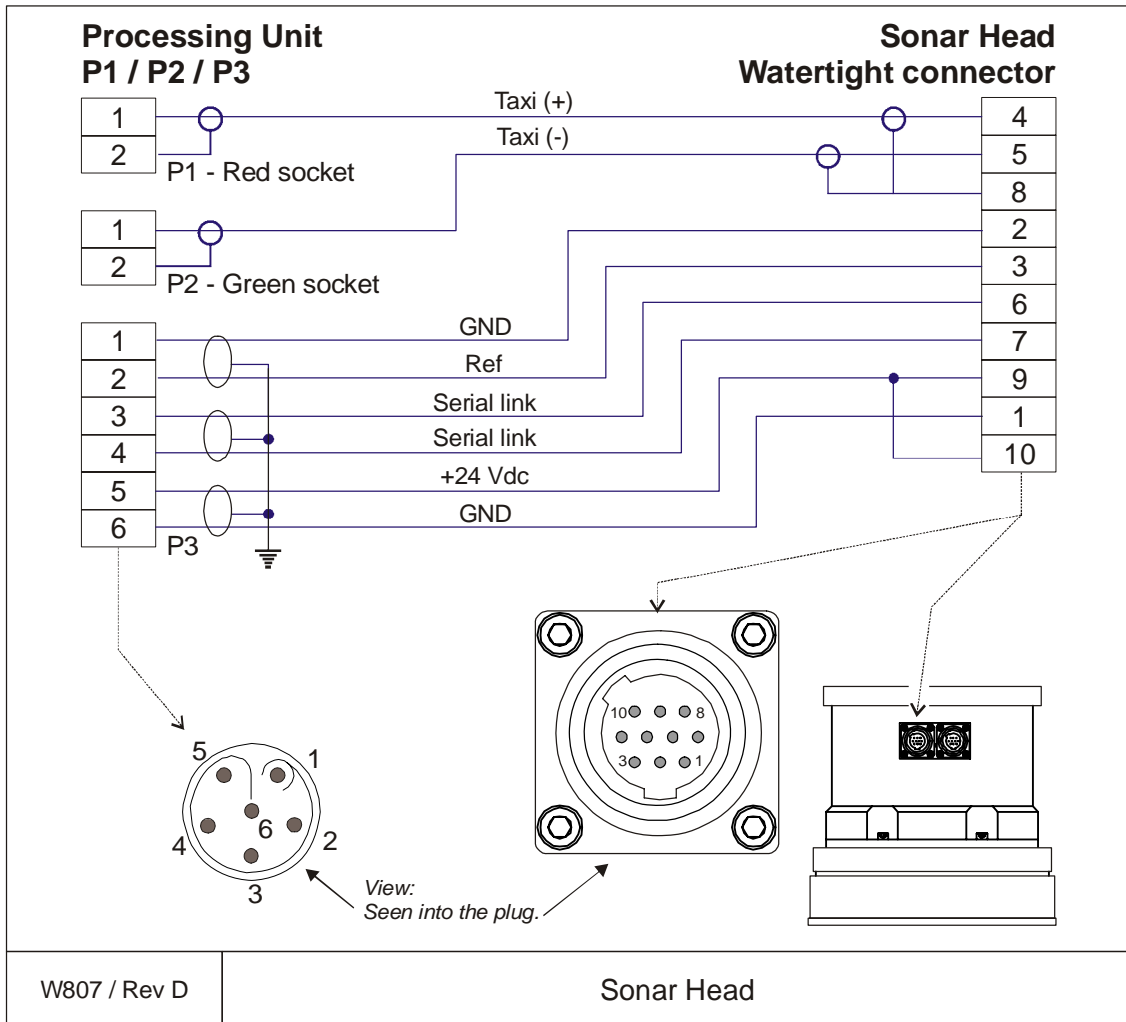

## 8.6 Sonar Head cable drawings

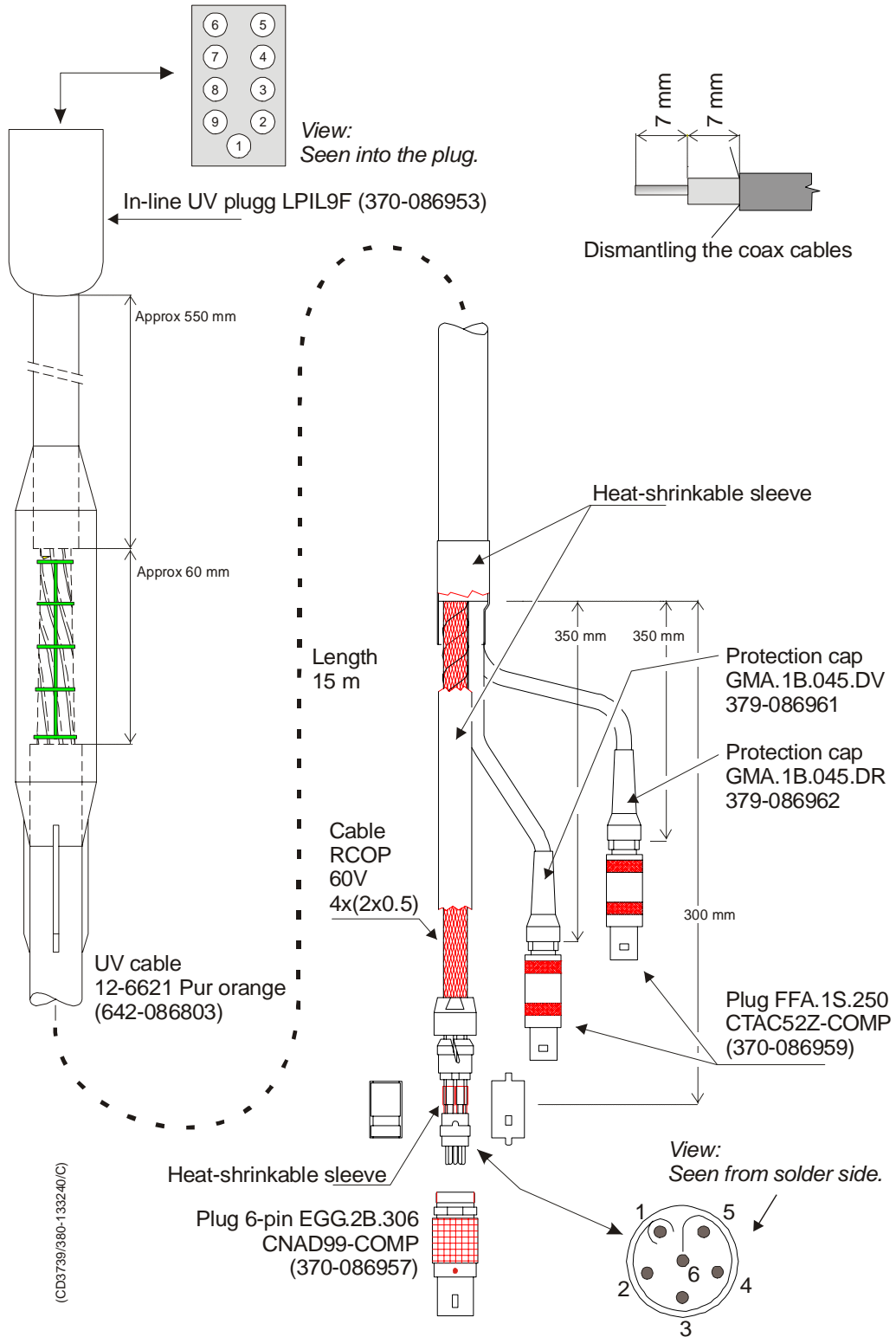

Figure 11 Sonar Head cable, assembly drawing

### Standard Sonar Head cable

Note

*On newer BIFB boards the TAXI interface is the same as in figure 13.*

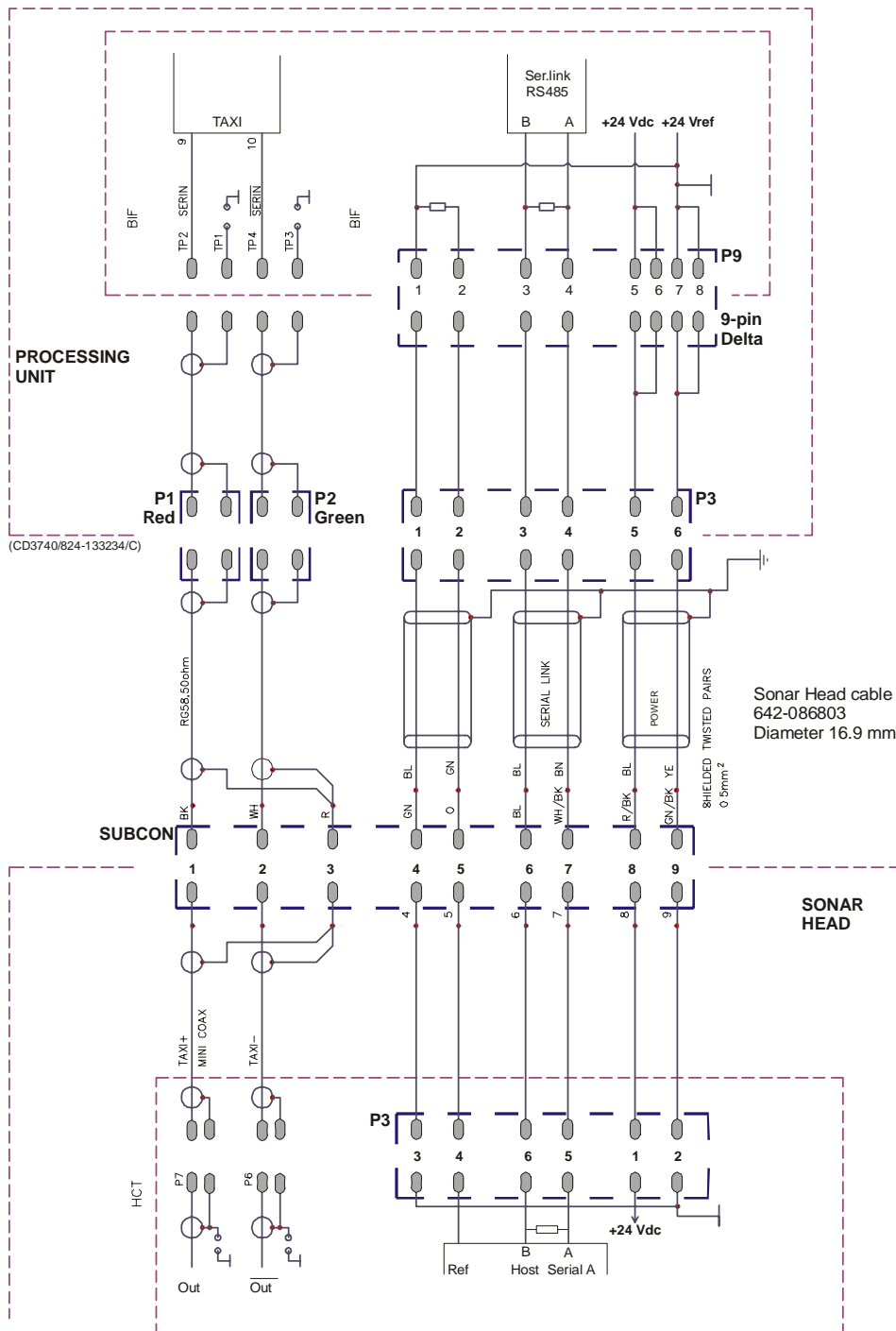

Figure 12 Sonar Head cable; connection diagram for Standard Processing Unit.

### AUV Sonar Head cable

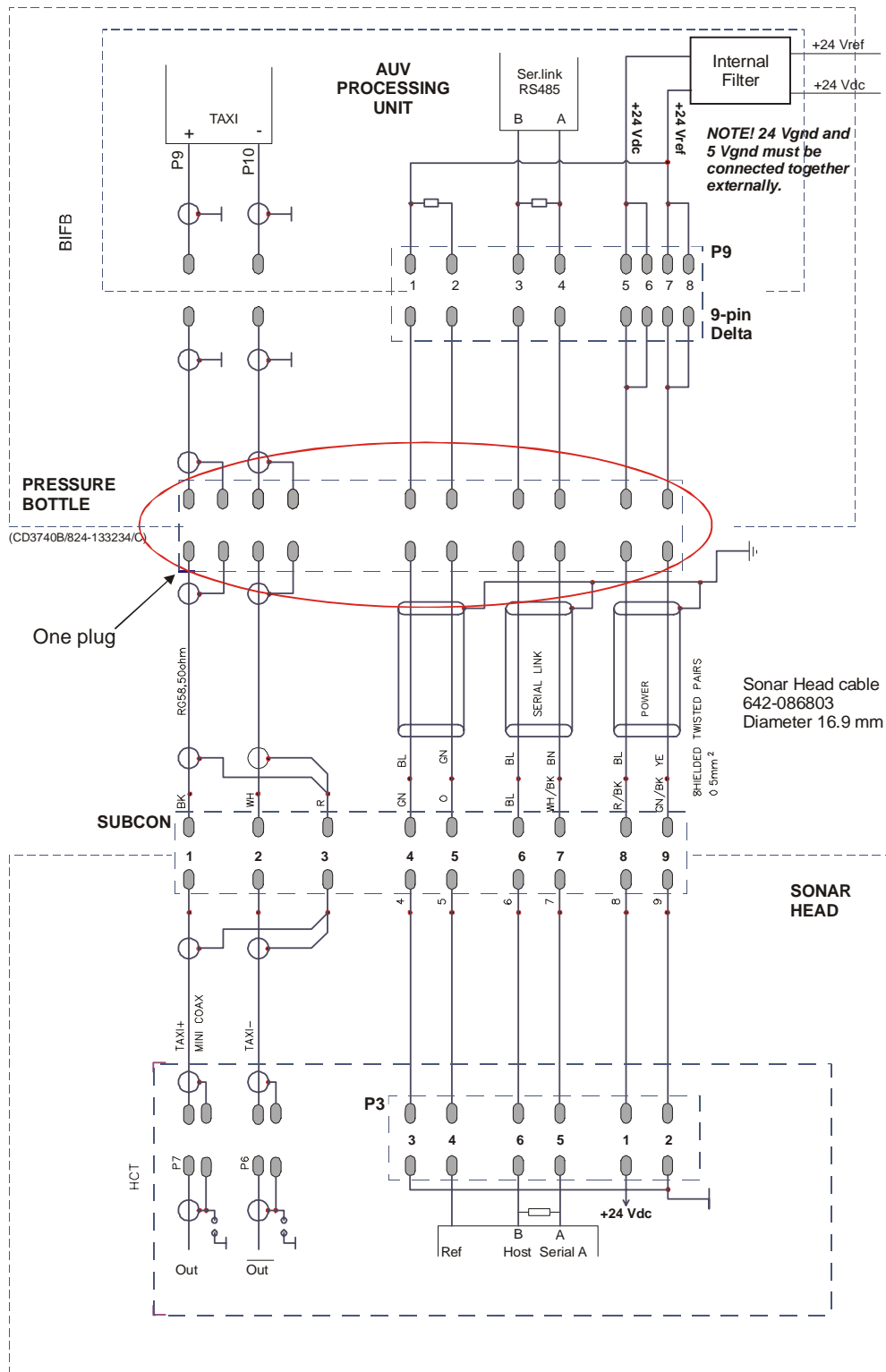

Figure 13 Sonar Head cable; connection diagram for AUV Processing Unit.

## 8.7 Sonar Head Connection

### Sonar Head cable

The standard Sonar Head cable delivered by Kongsberg Maritime has three plugs for connection to the standard Processing Unit. These plugs must be substituted by one underwater plug with minimum 10 pins.

A 4 meter cable without connectors in the “Processing Unit end” is available from Kongsberg Simrad.

This can be ordered on registration number:

- 380-212985.

### Internal wiring inside the bottle

Cabling from the underwater plug to the AUV Processing Unit BIFB board:

- Two mini coax cables must be used for the TAXI high speed up-link.
- A multi wire cable must be used to connect 24 V, RS485 serial line.

Plug and cable specifications (not supplied by Kongsberg Maritime):

- 2 mini coax connectors to plug into the BIFB board.
- 2 mini coax cable for the TAXI link.
- Plug for power and serial link for connection to the BIFB board: standard 9 pins delta plug.
  - Minimums cable dimensions: 0.5 mm<sup>2</sup>.

→ *For more details, refer to drawing on page 109.*



## Serial Line Board (CI-104JS)

### Purpose and description

This is a commercial circuit board designed and produced by Moxa Technologies. It is located in the Processing Unit.

The board is a cabling space saver that features a built-in RJ45 bracket to save cable layout space and reduce cost.

It has surge protection and ISA bus.

Note

*A software setup has been done at Kongsberg Maritime to configure the board.*

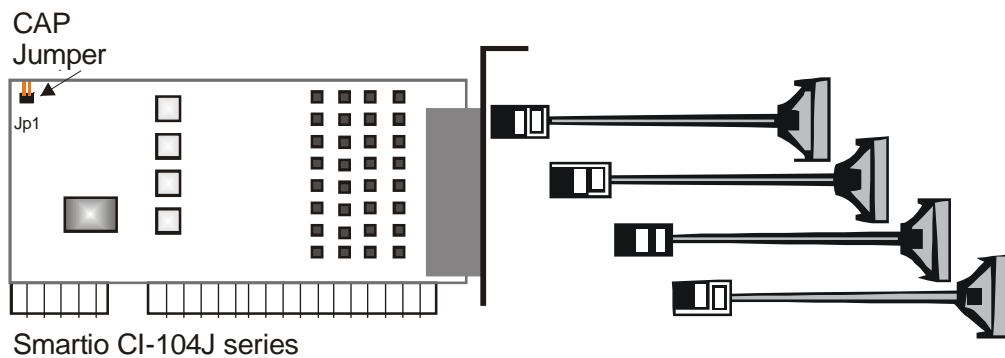

Figure 14 Illustration of the Serial Line Board.

### How it works

The Smartio CI-104JS Series provides 4 RJ-45 sockets for connection, which save a lot of cable space.

### Surge Protection

To prevent the board from damage caused by lightning or high potential voltage, TVSS (Transient Voltage Surge Suppressor) technology is introduced in Smartio CI-104JS to protect the board. This is critical to harsh environment such as factory.

### Specifications

Connector type	RJ-45
Bus	ISA (16 bit)
Serial	RS-232
Ports (interface)	4
Power requirements	83 mA max. (-12V), 57 mA max. (+12V), 100 mA max. (+5V)

Operating temperature	0° - 55°C
Dimensions	157 x 83 mm (width x depth)
Surge protection	25 KV ESD, 2 KV EFT

**Facilities**

No switches.

**References**

For more information, refer to webpage [www.moxa.com](http://www.moxa.com).

## 4-Ports Serial Line Board (C114P)

### Purpose and description

This is a commercial circuit board designed and produced by Moxa Technologies. This is identified as C114P, and is located in the Processing Unit.

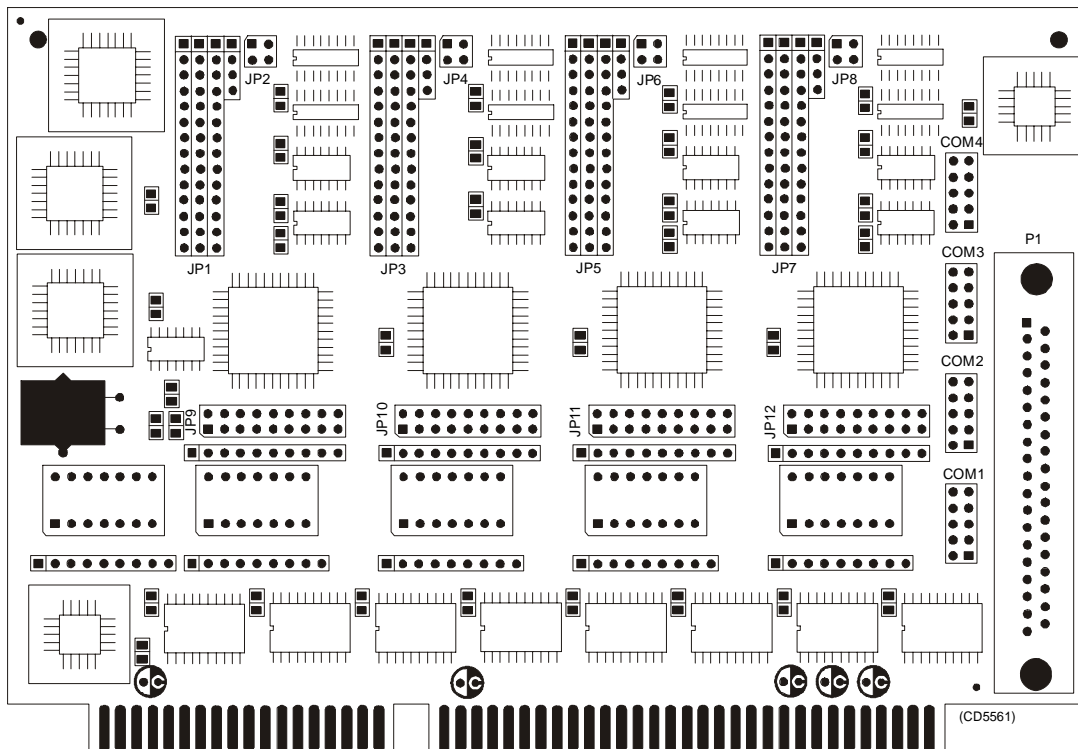

Figure 15 The C114P layout

### How it works

Each of the 4 ports can be configured to RS-232, RS-422, or RS-485 interface individually, but only RS-232 will work on the EM 2000 system.

### Facilities

#### LEDs

None.

#### Jumpers

The C114 is set up with IRQ 11 on the jumpers JP9, JP10, JP11 and JP12.

#### Links

### Note

*The following settings are only valid for new boards (version 2). For elder boards (version 1) the settings will be inverted. In the table below, the settings that are OFF will be ON and vice versa.*

**Note**

*This does NOT apply for SW 5, bit 7, which must always be ON.*

The settings of the C114P DIP switches for use in the EM 2000 are listed in the table below:

Switch	1	2	3	4	5	6	7
SW 5	ON	ON	OFF	OFF	OFF	ON	ON
SW 1	ON	ON	ON	ON	OFF	OFF	ON
SW 2	OFF	ON	ON	ON	OFF	OFF	ON
SW 3	ON	OFF	ON	ON	OFF	OFF	ON
SW 4	OFF	OFF	ON	ON	OFF	OFF	ON

Connections

The C114P contains one DB-37 female connector on the rear side of the circuit board. It comes with a cable; one terminal is a 37-pin male D-type and the other terminal is a four 9-pin male D-type connectors. This is not used.

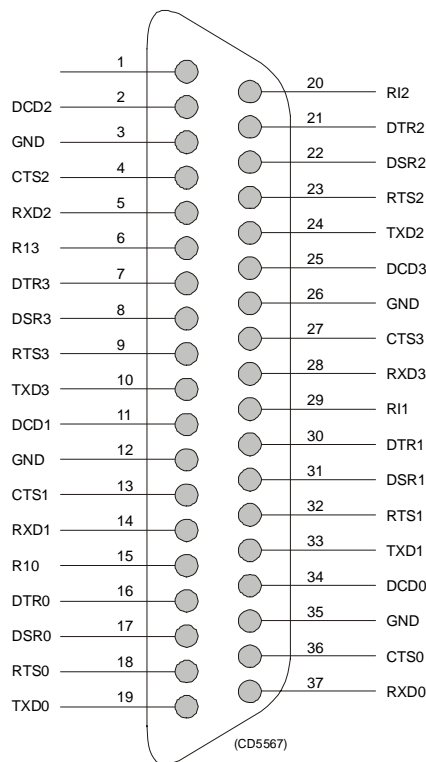
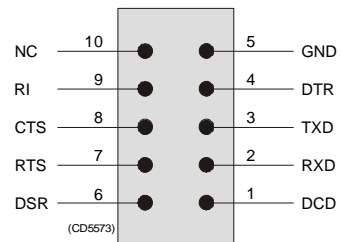

*Figure 17 DB-37 pin assignment*

- Refer to figure 17 and 18 for pin assignments.
- Refer to figure 16 for pin assignments.

In addition, four 10-pin pin-head connectors corresponds to the DB-37 connector on the board of C114P. These four connectors are called COM1, COM2, COM3 and COM4, and are connected directly to the Processing Unit bottom plate.

*Figure 16 10-pin header connector pin assignment*



*Figure 18 DB-9 pin assignment*

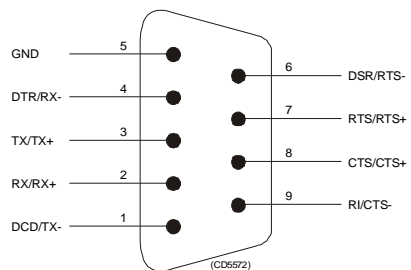

**References**

For more information, refer to webpage [www.moxa.com](http://www.moxa.com).

## 8.8 Basic cabling requirements

### Cable trays

All permanently installed cables associated with the system must be supported and protected along their entire lengths using conduits and/or cable trays. The only exception to this rule is over the final short distance (max. 0.5 metre) as the cables run into the cabinets/units to which they are connected. These short service loops are to allow the cabinets to move on their shock mounts, and to allow maintenance and repair.

- Wherever possible, cable trays must be straight, accessible and placed so as to avoid possible contamination by condensation and dripping liquids (oil, etc.). They must be installed away from sources of heat, and must be protected against physical damage. Suitable shields must be provided where cables are installed in the vicinity of heat sources.
- Unless it is absolutely unavoidable, cables should not be installed across the vessel's expansion joints. If the situation is unavoidable, a loop of cable having a length proportional to the possible expansion of the joint must be provided. The minimum internal radius of the loop must be at least twelve times the external diameter of the cable.
- Where a service requires duplicate supply lines, the cables must follow separate paths through the vessel whenever possible.
- Signal cables must not be installed in the same cable tray or conduit as high-power cables.
- Cables containing insulation materials with different maximum-rated conductor temperatures should not be bunched together (that is, in a common clip, gland, conduit or duct). When this is impractical, the cables must be carefully arranged such that the maximum temperature expected in any cable in the group is within the specifications of the lowest-rated cable.
- Cables with protective coverings which may damage other cables should not be grouped with other cables.
- Cables having a copper sheath or braiding must be installed in such a way that galvanic corrosion by contact with other metals is prevented.
- To allow for future expansion of the system, all cables should be allocated spare conductor pairs. Also, space within the vessel should be set aside for the installation of extra cables.

### **Radio Frequency interference**

All cables that are to be permanently installed within 9 m (30 ft) of any source of Radio Frequency (RF) interference such as a transmitter aerial system or radio transmitters, must, unless shielded by a metal deck or bulkhead, be adequately screened by sheathing, braiding or other suitable material. In such a situation flexible cables should be screened wherever possible.

It is important that cables, other than those supplying services to the equipment installed in a radio room, are not installed through a radio room, high power switch gear or other potential sources of interference. Cables which must pass through a radio room must be screened by a continuous metal conduit or trunking which must be bonded to the screening of the radio room at its points of entry and exit.

### **Physical protection**

Cables exposed to the risk of physical damage must be enclosed in a steel conduit or protected by a metal casing unless the cable's covering (e.g. armour or sheath) is sufficient to protect it from the damage risk.

Cables exposed to an exceptional risk of mechanical damage (for example in holds, storage-spaces and cargo-spaces) must be protected by a suitable casing or conduit, even when armoured, if the cable covering does not guarantee sufficient protection for the cables.

Metallic materials used for the physical protection of cables must be suitably protected against corrosion.

### **Grounding**

All metallic cable coverings (armour, metallic sheathing etc.) must be electrically connected to the vessel's hull at both ends except in the case of final sub-circuits where they should be connected at the supply end only.

Grounding connections should be made using a conductor which has a cross-sectional area appropriate for the current rating of the cable, or with a metal clamp which grips the metallic covering of the cable and is bonded to the hull of the vessel. These cable coverings may also be grounded by means of glands specially intended for this purpose and designed to ensure a good ground connection. The glands used must be firmly attached to, and in good electrical contact with, a metal structure grounded in accordance with these recommendations.

Electrical continuity must be ensured along the entire length of all cable coverings, particularly at joints and splices. In no case should the shielding of cables be used as the only means of grounding cables or units.

Metallic casings, pipes and conduits must be grounded, and when fitted with joints these must be mechanically and electrically grounded locally.

### **Cable connections**

All cable connections are shown on the applicable cable plan and interconnection diagrams.

Where the cable plan shows cable connections outside an equipment box outline, the connections are to be made to a plug or socket which matches the plug or socket on that particular item of equipment.

Where two cables are connected in series via a junction box or terminal block, the screens of both cables must be connected together but not grounded.

### **Cable terminations**

Care must be taken to ensure that the correct terminations are used for all cable conductors, especially those that are to be connected to terminal blocks. In this case, crimped sleeve-terminations must be fitted to prevent the conductor core from fraying and making a bad connection with the terminal block. It is also of the utmost importance that where crimped terminations are used, the correct size of crimp and crimping tool are used. In addition, each cable conductor must have a minimum of 15 cm slack (service loop) left before its termination is fitted.

### **Cable identification**

Cable identification codes corresponding to the cable number shown in the cable plan must be attached to each of the external cables. These identification codes should be positioned on the cable in such a way that they are readily visible after all panels have been fitted. In addition, each cable conductor should be marked with the terminal board number or socket to which it is connected.

## 9 ALIGNMENT

### 9.1 Introduction

The EM 2000 is a precision instrument for bathymetric swath mapping. To be able to produce data that are both detailed and correct, it is necessary to calibrate the survey vessel more accurately than what may have been standard practice earlier. The required calibration consists of:

- measurement of where sensors are located
- measurement of how sensors are oriented
- measurement of the waterline vertical location
- alignment of angular measurement sensors
- determination of any offsets in sensor data
- determination of any time delays in sensor data

The results, with all measurements taken in a common vessel coordinate system, are to be entered in the EM 2000 Operator Station.

Calibration must be taken seriously. It is recommended that this task and the continued control of the soundings' consistency is assigned to one motivated and qualified person in the organization. To achieve the best results, the calibration must be planned carefully, and monitored throughout the installation and the first sea trials. It is also recommended to repeat the calibration procedures with regular checks throughout the operation of the vessel.



---

## 9.2 Measurements

### Objectives

#### The measurements to be made after installation are:

- the horizontal and vertical positions of the EM 2000 Sonar Head and Transmit Transducer.
- the angular orientation of the Sonar Head and Transmit Transducer
- the horizontal and vertical positions of the motion sensor.
- the horizontal and vertical positions of the positioning system (radio or GPS antenna).

The measurements on the Sonar Head and the Transmit Transducer are easiest to make with the vessel in dry dock, the others may be done with the vessel berthed.

It is however recommended that all measurements/offsets are established in dry dock. This gives the best alignment accuracy.

During the sea trials (SAT), calibration surveys are required as described in the EM 2000 Operator Manual. Based on the calibration parameters determined from these surveys, proper values are entered into the EM 2000 Installation menu found in the operator software.

It is advisable to perform a calibration survey at regular intervals or prior to any large survey to check the performance of the sensors. If any sensor has been replaced or another navigation antenna is installed etc, a new calibration is required.

### Alignment of motion and heading sensors

The alignment of the motion sensor and the heading sensor must be adjusted so that they provide zero values for pitch, roll and heading with the vessel lying still with normal trim and a true North heading. It is recommended that this takes place in the dry dock. Alternatively, the offsets from zero must be determined. This is easiest to do with the vessel berthed. Follow the procedures in the applicable sensor manuals.

### Time delays

Any time delays of the motion sensor and positioning data from their time of validity to the time when they are available at the interface ports of the EM 2000 must be determined. The information may be available from the sensor manufacturer.

### **Water line**

Finally, the vertical position of the water line must be measured with the vessel in normal trim. This should preferably be done at normal survey speed, and must of course be repeated as the loading and hence the draft of the vessel changes.

### **Vessel coordinate system**

A Cartesian coordinate system must be defined for the vessel. The following definition must be adhered to:

- $X$  = forwards
- $Y$  = to starboard
- $Z$  = pointing downwards.

There is no restriction on where the coordinate system's origo is located.

---

#### Note

*The sea surface with the vessel in normal trim defines the horizontal (X-Y) plane. The water line should therefore be marked on the hull with the vessel in normal trim before any dry docking.*

---

Reference points must be established on the vessel at selected positions. These are needed during measurements of the sensor positions. Visual markings at these positions should be prepared and noted on the vessel drawings with XYZ coordinates in the vessel coordinate system.

### **Sensor location**

#### **Overview**

The EM 2000 Sonar Head and the Transmit Transducer must be located according to the guidelines given elsewhere in this installation manual. With regard to the location of other sensors the following guidelines should be followed, but otherwise should be chosen according to the manufacturer's documentation.

#### **Motion sensor**

The system motion sensor should normally be mounted on the centerline of the vessel, either close to the EM 2000 Sonar Head or close to the vessel's CG (Center of Gravity).

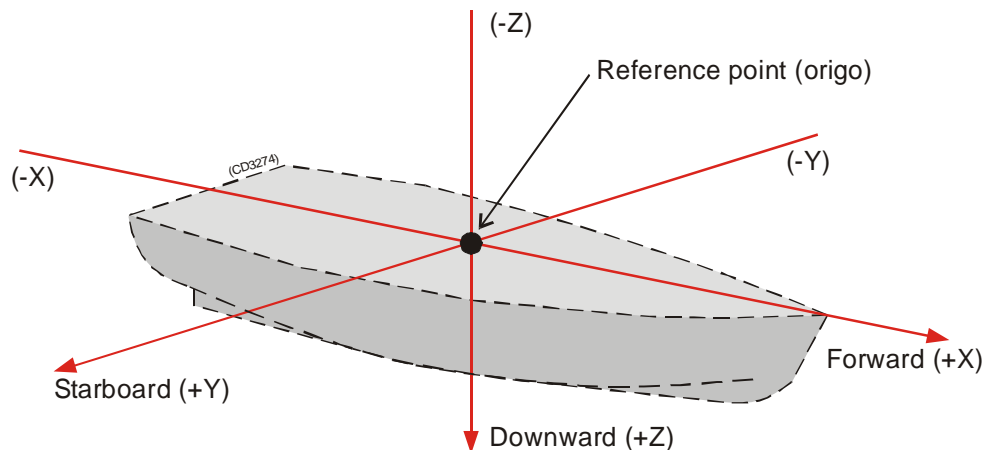

Figure 19 Reference points

The latter point is recommended if the sensor is used for other purposes than just with the EM 2000, or if its accuracy is sensitive to horizontal accelerations.

If there is any point in the fore-aft direction which does not change height with respect to the waterline with changes in vessel speed, then this is the ideal location for the motion sensor. This will eliminate any errors from squat induced height changes which is not measured by current motion sensors.

---

Note *If the alongship distance between the Sonar Head and the motion sensor is larger than 20 m, the system accuracy will be degraded.*

Note *The motion sensor must be aligned with the vessel centerline.*

---

### Heading sensor

The accuracy of the heading sensor may be sensitive to accelerations and should therefore be mounted close to the Center of Gravity (CG).

---

Note *The heading sensor must be aligned with the vessel centerline.*

---

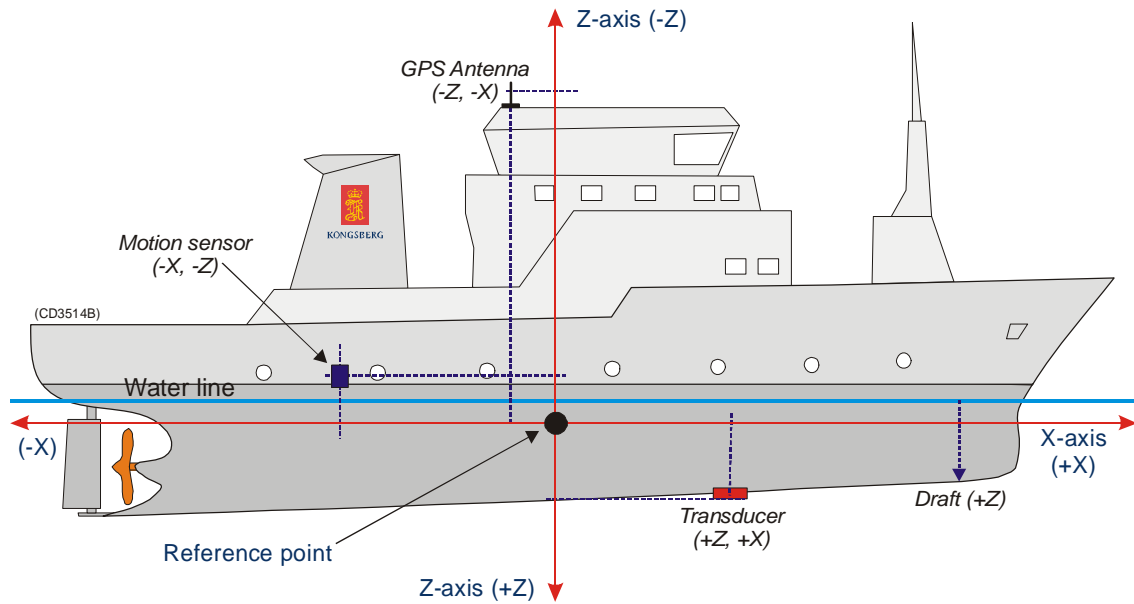

Figure 20 Reference points and CG

## Measurement accuracy

### Overview

The required measurement accuracies given below have been determined from considerations on how they contribute to total system accuracy, i.e. that any errors in these measurements shall not significantly contribute to depth or position errors in the soundings.

### Note

*The given accuracies are maximum values, and if easily achievable, better accuracies should be obtained. The relative accuracy between Rx and Tx must be within  $\pm 0.10^\circ$  in the heading alignment.*

The relative accuracy between Rx and Tx must be within  $\pm 0.10^\circ$  in the heading alignment.

### Sonar Head (Rx)

- 1 The vertical location must be measured to an accuracy of  $\pm 2$  cm.
- 2 Measure the horizontal location to an accuracy of  $\pm 5$  cm.
- 3 Measure the heading to an accuracy of  $\pm 0.10^\circ$ .
- 4 Measure the roll of the Rx to an accuracy of  $\pm 0.025^\circ$ .

- 
- 5 Measure the pitch to an accuracy of  $\pm 0.25^\circ$ .

### **Transmit Transducer (Tx)**

- 1 The vertical location must be measured to an accuracy of  $\pm 2$  cm.
- 2 Measure the horizontal location to an accuracy of  $\pm 5$  cm.
- 3 Measure the heading to an accuracy of  $\pm 0.10^\circ$ .
- 4 Measure the roll of the Tx to an accuracy of  $\pm 0.25^\circ$ .
- 5 Measure the pitch to an accuracy of  $\pm 0.25^\circ$ .

### **Motion sensor**

- 1 Measure the vertical location of the motion sensor to an accuracy of  $\pm 10$  cm.
  - 2 Measure the horizontal location of the motion sensor to an accuracy of  $\pm 5$  cm.
- 

#### Note

*If the Motion Sensor performs lever arm correction to give heave data valid for another location than where it is actually mounted, it is this location which must be measured.*

---

- 3 Align (set up) the forward axis on the motion sensor with the X-axis of the vessel's coordinate system to an accuracy of  $\pm 0.10^\circ$ .

The motion sensor must be aligned (set up) such that the indicated roll and pitch angles from the sensor when the vessel has a normal trim, i.e. the coordinate system's horizontal plane is horizontal, should be less than  $\pm 0.05^\circ$  for the roll and  $\pm 0.05$  to  $0.25^\circ$  for the pitch.

If the alongship distance between the Sonar Head and the Motion Sensor exceeds 5 m, its indicated pitch angle for vessel in normal trim must be less than  $0.25^\circ$ . If the distance is 20 m, the indicated pitch should be less than  $0.05^\circ$ . A linear interpolation for the other distance alternatives is recommended.

### **Heading sensor**

The heading sensor must be aligned with the X-axis of the vessel's coordinate system to an accuracy of  $\pm 0.25^\circ$ . If this is not possible, the resulting offset must be known to the same accuracy.

### **Positioning system**

- 1 The vertical location of the positioning system antenna must be measured to an accuracy of  $\pm 2$  cm.

- This is only required if the positioning system measures position in the vertical axis. This will be usually only be the case for real-time kinematic GPS systems and some optical positioning systems.
- 2 The positioning system antenna's horizontal location must be measured to an accuracy of  $\pm 5$  cm or 20% of the positioning system's accuracy.

**Water line**

- 1 The vertical distance to the waterline should be measured with an accuracy of  $\pm 2$  cm.
- 

Note

*With the vessel in normal trim, i.e with an indicated pitch angle of zero from the motion sensor, the distance to the waterline may be measured anywhere on the vessel, but otherwise it must be measured at the alongship physical location of the motion sensor. The measurement should be taken on both sides of the vessel and averaged to remove any roll effects. Simultaneous measurements are required if the vessel is moving.*

---

### 9.3 Heading sensor calibration

It may not be possible to calibrate the heading sensor accurately enough through sea trials, so the calibration is normally done with the vessel berthed.

On the quay the geographical coordinates of two points must be known or measured so that the heading of a line on the quay can be established to an accuracy of better than  $\pm 0.1^\circ$ . The distance from two points on the centerline of the vessel (fore and aft) are then measured so that the vessel's heading can be calculated. The heading sensor is then aligned to this heading or its measured offset determined.

The vessel must be turned  $180^\circ$  as many times as necessary with the alignment or offset checked until the **mean error** is within the specifications of the heading sensor.

## 9.4 Summary

The table below give a summary of the requirements to the accuracy of the measurements.

<b>Sonar Head</b>	<b>Measurement accuracy</b>
Position (x, y) [m]	$\pm 0.05$
Position (z) [m]	$\pm 0.02$
Pitch [deg]	$\pm 0.25$
Roll [deg]	$\pm 0.025$
Heading [deg]	$\pm 0.10$

<b>Transmit Transducer</b>	<b>Measurement accuracy</b>
Position (x, y) [m]	$\pm 0.05$
Position (z) [m]	$\pm 0.02$
Pitch [deg]	$\pm 0.25$
Roll [deg]	$\pm 0.25$
Heading [deg]	$\pm 0.10$

<b>Motion sensor</b>	<b>Measurement accuracy</b>
Position (x, y) [m]	$\pm 0.05$
Position (z) [m]	$\pm 0.10$
Pitch [deg]	$\pm 0.05$
Roll [deg]	$\pm 0.05$
Heading [deg]	$\pm 0.10$

<b>Heading sensor</b>	<b>Measurement accuracy</b>
Heading [deg]	$\pm 0.10$

<b>Positioning system (antenna)</b>	<b>Measurement accuracy</b>
Position (x, y) [m]	$\pm 0.02$
Position (z) [m]	$\pm 0.05$

<b>Water line</b>	<b>Measurement accuracy</b>
Position (z) [m]	$\pm 0.02$



## 10 INSTALLATION CHECKS

---

**Warning**

*These checks must be completed before any power is switched onto the system.*

---

### 10.1 Visual inspection of units

**Scope**

After the physical installation has been carried out, all the system units must be visually checked to ensure that the EM 2000 units have been installed correctly. You must satisfy yourself that the units have been mounted in the correct locations, correctly orientated (eg. the right way up) and are correctly secured.

**Inspections****Operator Station**

Perform a close visual inspection of the Operator Station according to the following procedure:

- 1 Check that the units are installed properly, secured, and that they are suitably orientated to enable easy operation.
- 2 Check that the units are not damaged.
- 3 Check that the air vents are not blocked.

**Processing Unit**

Perform a close visual inspection of the EM 2000 Processing Unit cabinet.

- 1 Check that the unit is installed in the correct location, and is suitably orientated to enable easy maintenance.
- 2 Check that the unit is not damaged.
- 3 Check that the air vents are not blocked.

## 10.2 Electrical checks

### Scope

This section of the manual contains the test procedures for the EM 2000 system's power and signal interface cables.

### Cabling

#### Visual cable inspection

Refer to the cable plans and interconnection diagrams, and check all power and interconnection cables. Any locally fitted plugs and connectors should also be checked to ensure that the correct types have been used for the specific locations. (Sealed or spark-proof connectors in areas where flammable gasses may accumulate, etc..)

Ensure that all cable connections have been made according to the cable plan, and that all connections are tight and secure. Ensure that all cables are correctly laid in conduits, or are otherwise protected according to the regulations and recommendations laid down by the vessel's registering authority. Ensure all protective covers are fastened correctly.

#### Cable connections and continuity

After the cable connections have been completed and the visual inspection has been carried out, all the cable cores must be checked for correct connection and continuity. Refer to the cable plans and interconnection diagrams, and check all interconnection cables. Any locally fitted plugs and connectors must be checked for shorts or open circuits. Ensure all cable connections have been made according to the cable plan, and that all connections are tight and secure.

The check procedure will require two engineers equipped with two-way communication devices; one will require continuity test equipment, while the other will require a suitable shorting strap.

Follow the check procedure below for each cable core:

- 1 Position yourselves one at each end of the cable to be checked. Good communications must be established between you and your assistant.
- 2 Ensure that the cable to be tested is not connected to any power source.
  - If a cable terminates in a plug at the unit, the test will be more easily conducted if the plug is disconnected.

- 3 Select one pair of cable cores, and check that the cores are connected to the correct terminals in the unit.
- 4 Connect your continuity tester to the two terminals in question and check the continuity.
  - If a low resistance exists between the two cores, this may indicate the cores are connected to circuits or units with low internal resistance. If this is the case, disconnect the cores from the terminal block and test again.
  - The resistance should be nearing  $\infty$  ohms.
- 5 Tell your assistant to short the two cores together. Repeat the previous test.
  - The resistance should be 0 (zero) ohms.
- 6 Tell your assistant to remove the shorting strap.
  - Check that the resistance reaches  $\infty$  ohms again.
- 7 Check each core's resistance to ground, and each core's resistance to all the other cores in the cable.
  - All results should be close to  $\infty$  ohms.
- 8 Assuming the test results are correct, the cores must be reconnected to the terminal block (if they had been removed), and the terminals checked to ensure they are tight.
- 9 On completion, move on to the next pair of cores and repeat the tests until the entire cable has been checked.

### **Operational voltages**

Check that the operational voltages on the equipment match the power available on the vessel.

### 10.3 Final checks

After installation, but before leaving port for the sea trials, the following checks must be done:

- 10** Check that the specified sacrificial anodes have been mounted, and that any specified anti-fouling paint has been applied correctly.
- 11** Check that all system units have been fastened properly and that all nuts and bolts have been tightened properly.
- 12** Check that the data from the motion sensor, the heading sensor and the positioning system are correctly read by the EM 2000 and that the values are reasonable.
- 13** Check that the echo sounder is acquiring reasonable sounding values.

---

Note

*To ensure proper functionality perform calibration and noise verification of the system. Refer to the Operator manual for more details.*

---

# 11 DRAWING FILE

## 11.1 Overview

This chapter contains cable details and installation drawings. The illustrations are based on the original system drawings and wiring diagrams.

- The illustrations are not in scale.
- The original drawings are available in electronic format (AutoCAD) upon request.

### **Cable details**

→ *Refer to page 62.*

### **Installation drawings**

If required, certain drawings may be supplied on AutoCad format. To order, contact Kongsberg Maritime and refer to the drawing number in the bottom right corner of the frame.

- *Rx 150 degrees system. Outline dimensions, page 106*
- *Rx 120 degrees system. Outline dimensions, page 107.*
- *Tx Outline dimensions, page 108.*
- *AUV Processing Unit, Sonar Head cable details, page 109.*
- *Standard Processing Unit, page 110.*
- *AUV Processing Unit. Outline dimension, page 110*
- *HWS10. Outline dimension, page 113.*

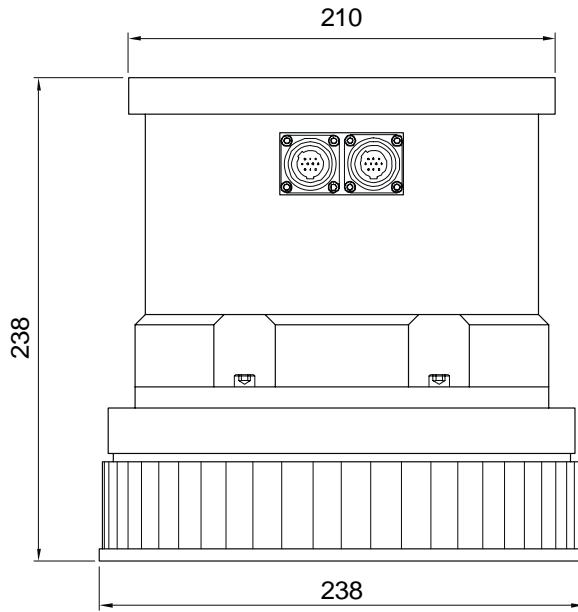

Receiver array

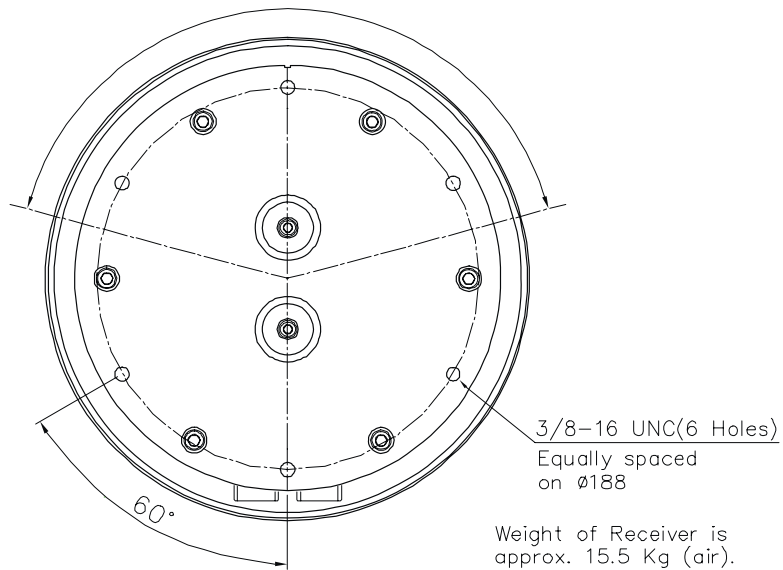

Page 1 of 1 (CD6312)	EM 2000 Rx Transducer, 150 degrees system Outline dimensions	<b>834-215553</b> Rev.B
-------------------------	---	----------------------------

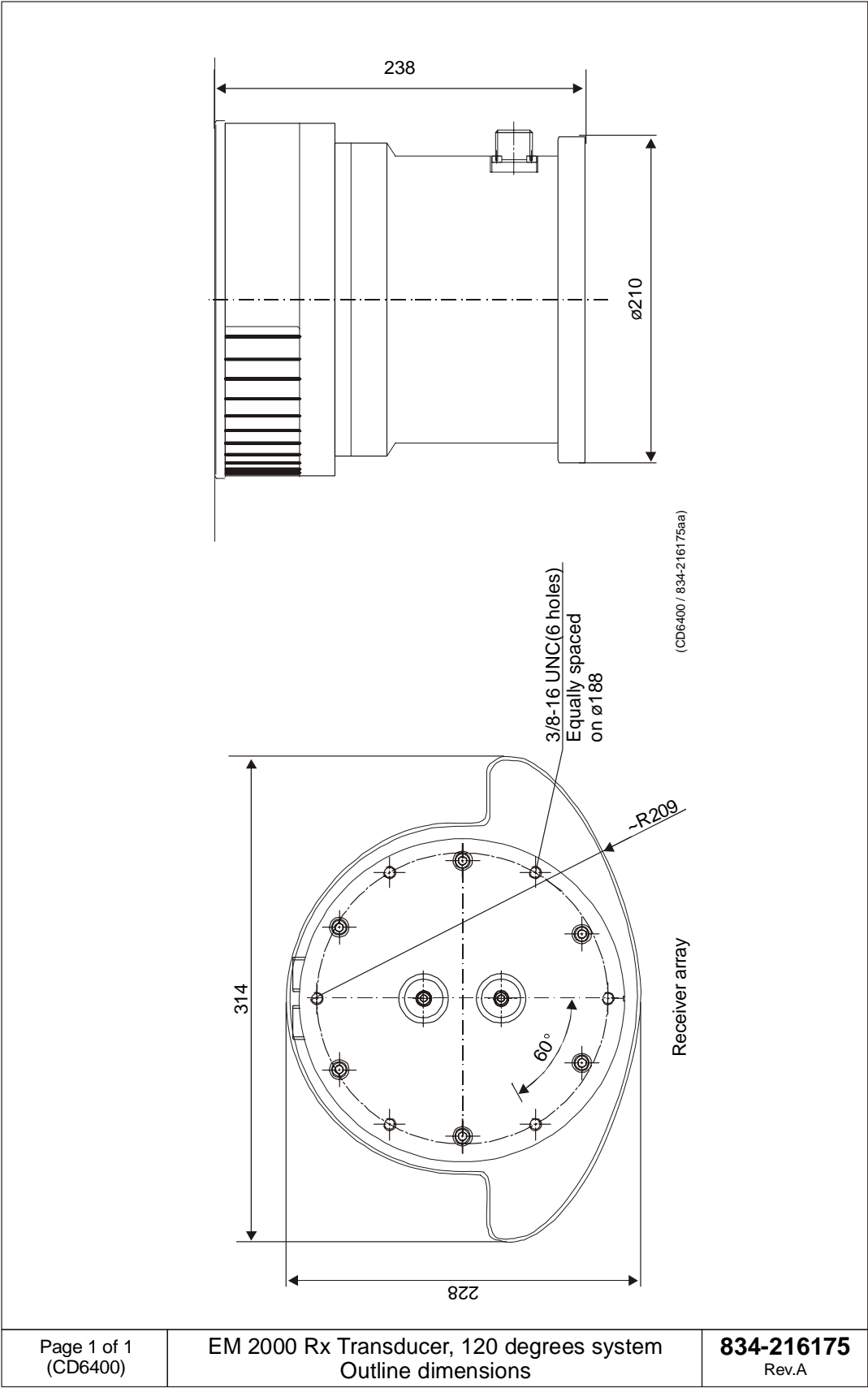

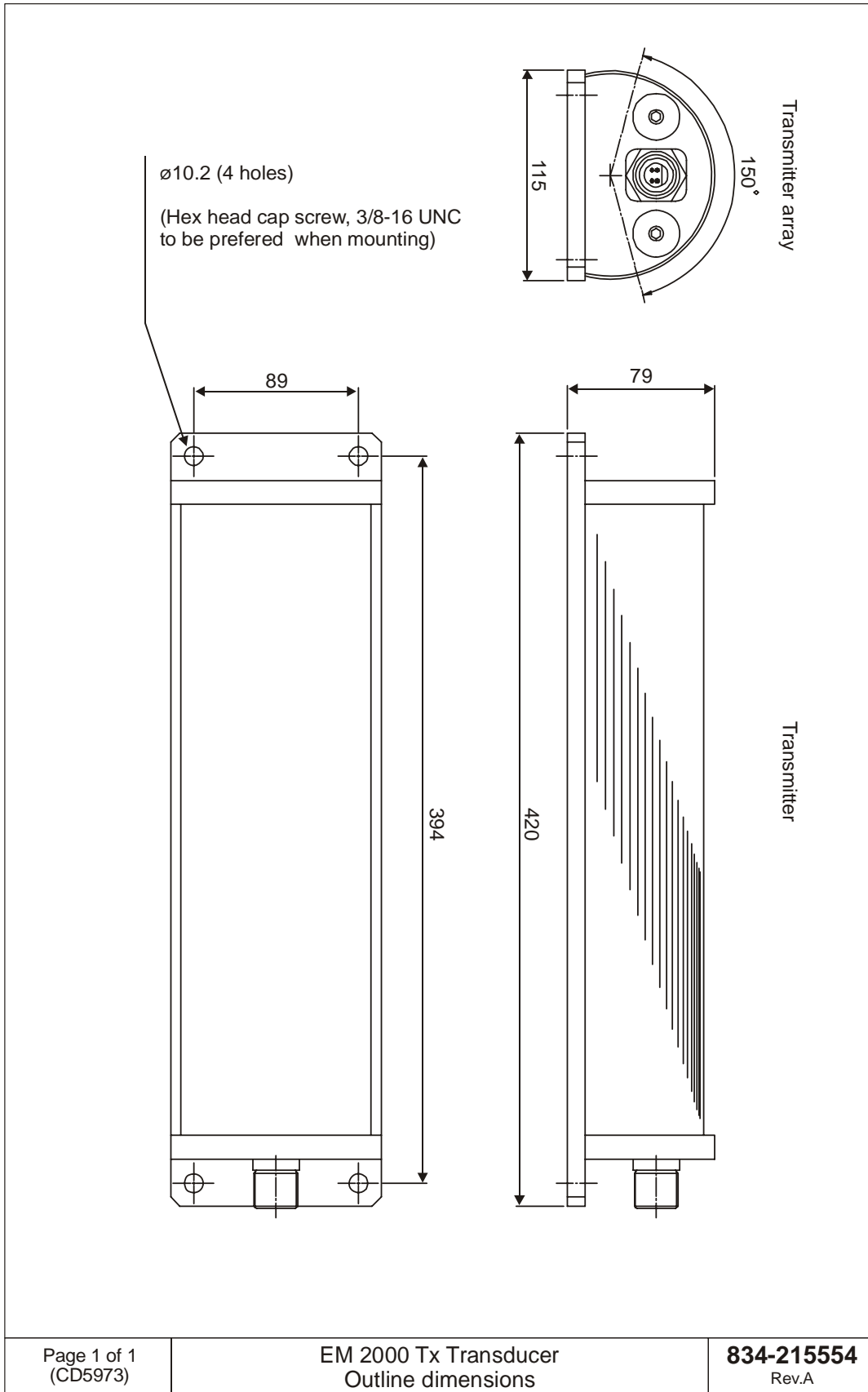



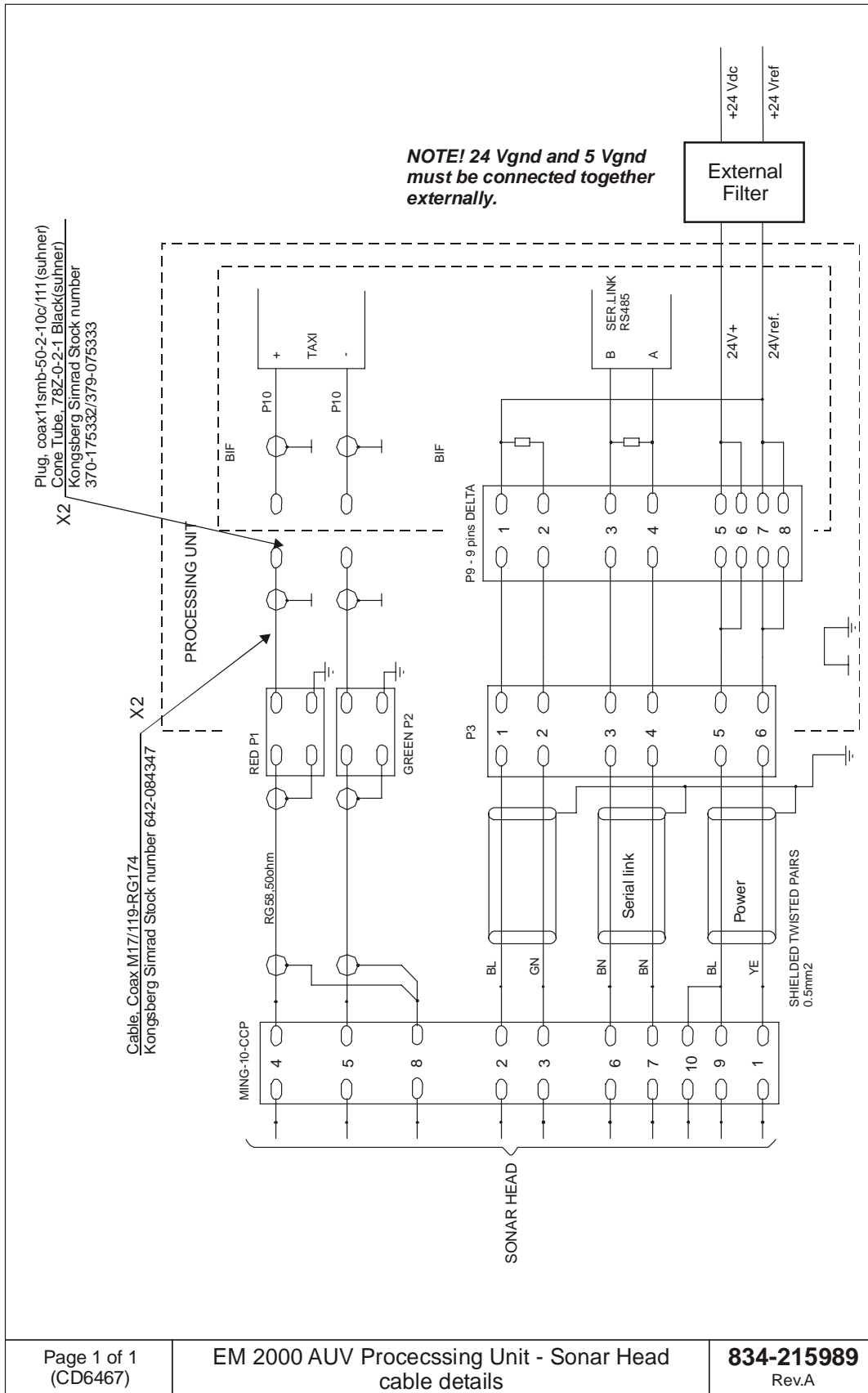

### Standard Processing Unit drawing

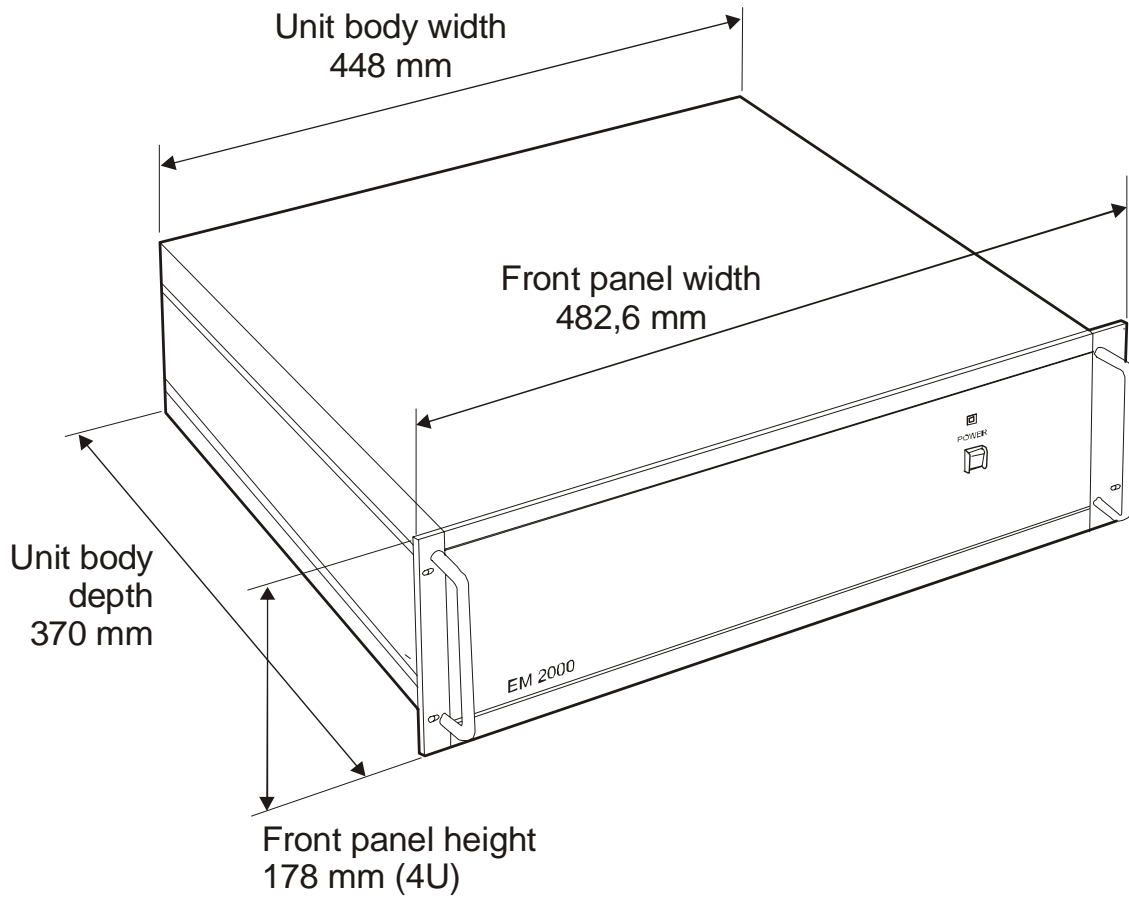

*Figure 21 Standard Processing Unit - Outline dimensions*

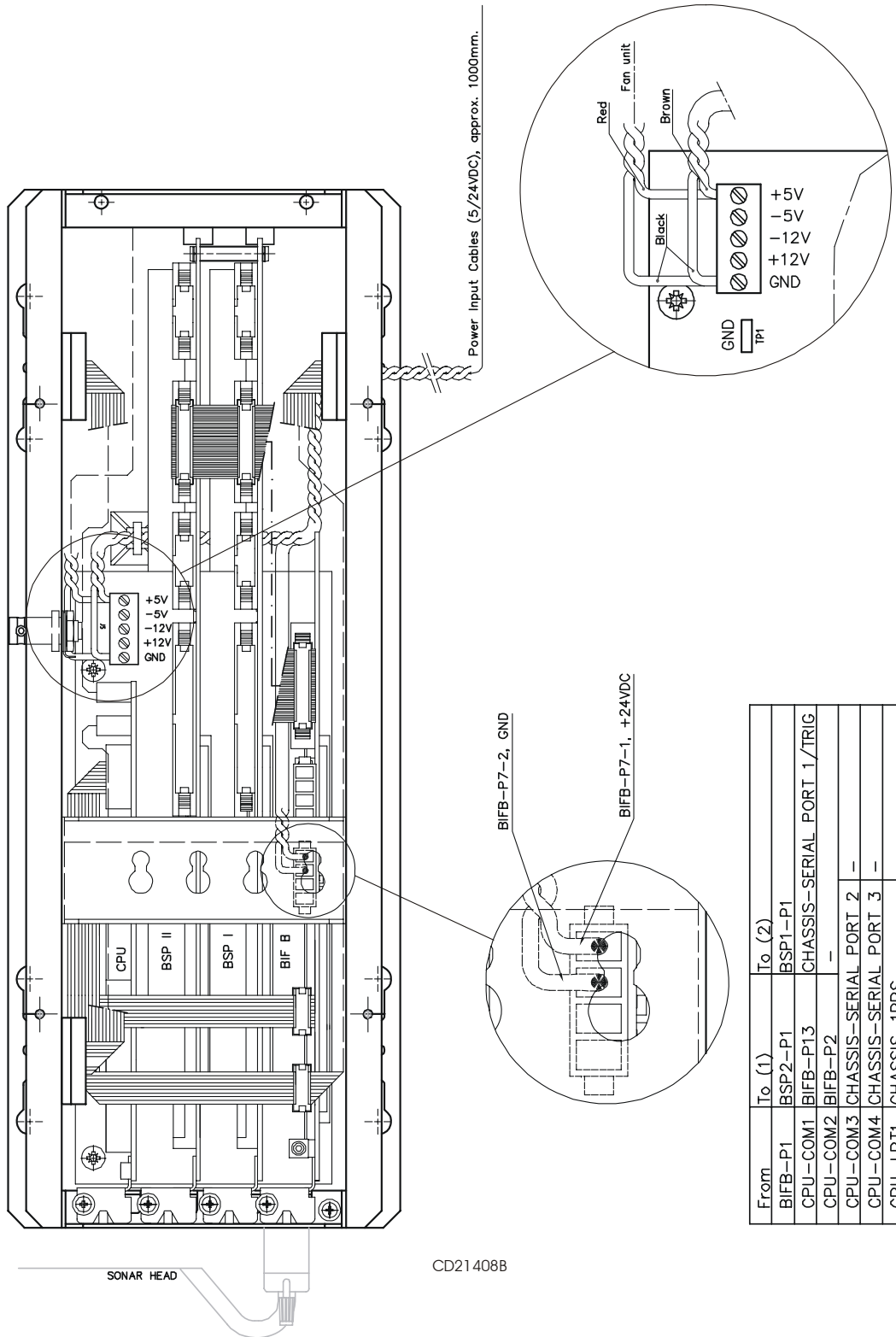
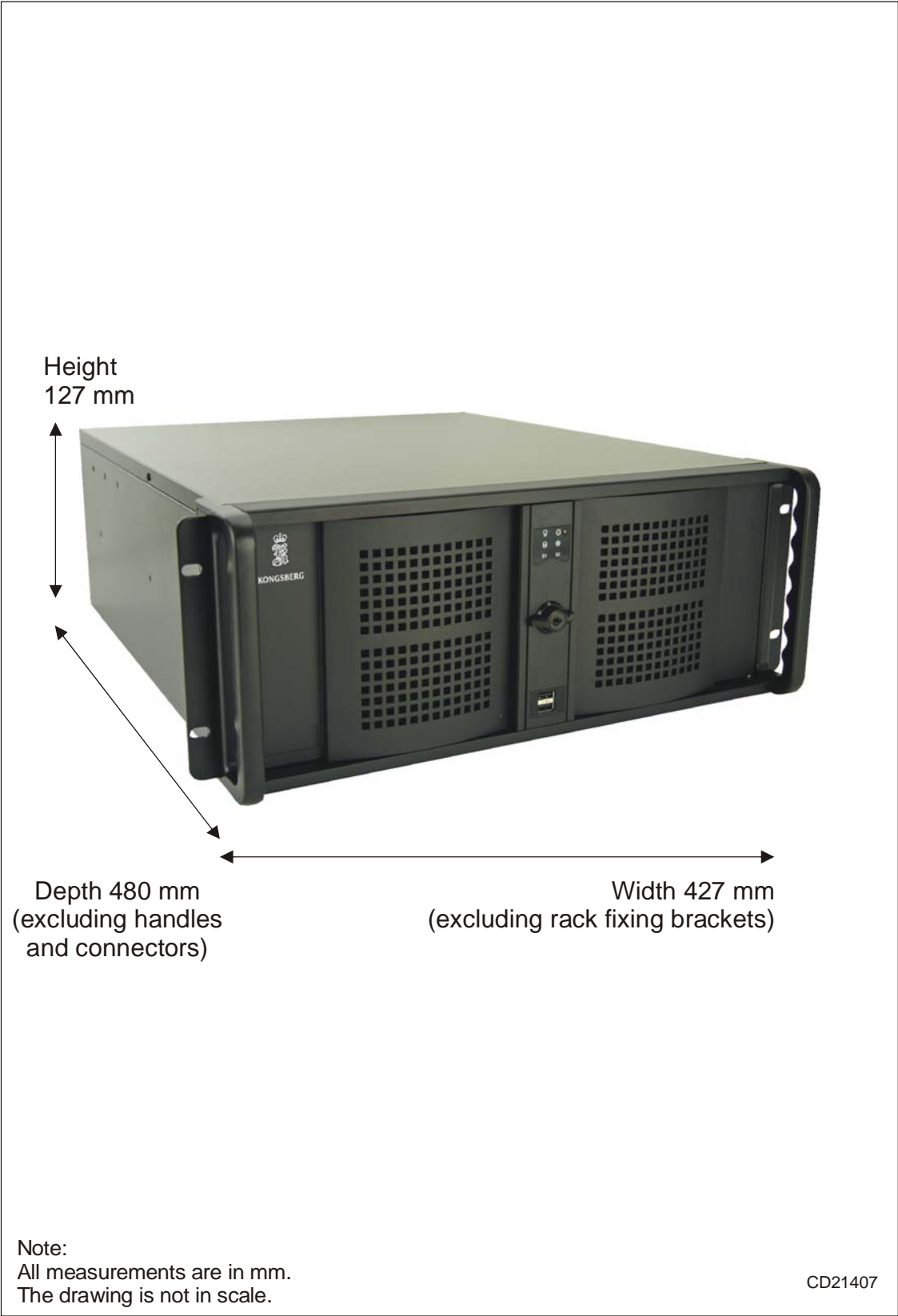

Figure 22 EM 2000 AUV Processing Unit - cabling details





*EM 2000 HWS10 - Outline dimensions*

# 12 INDEX

The next pages presents the index of this manual.

---

## A

Alignment, 92  
Ambient humidity, 12  
Ambient temperature, 12  
AUV Processing Unit, Outline dimension drawing, 112

## B

Batteries, 13  
Boundary water level, 32  
Bulbous bow, 34

## C

Cable layout, 52  
Cable trays, 89  
Cables  
  Connections, 91  
  Identification, 91  
  Terminations, 91  
Cabling, Requirements, 89

## E

Electric shock, 5  
Electrostatic Discharge (ESD), 19  
ESD precautions, 19  
External interfaces, Introduction, 48

## G

Grounding, 90

## H

Heading sensor, 95

## I

Illustrations:  
  Reference points, 95  
  Reference points and CG, 96  
Installation requirements, 8

## M

Measurement accuracy, 96

## O

Operator Station, installation, 26  
Operator station, 24  
Original packing crate, 11  
Overview, 2

## P

Physical protection, 90  
Power switch, 5  
Processing Unit, Installation, 28  
Propeller noise, 33  
Protection, 19  
Protruding objects, 34  
Purpose, 1

## R

Radio Frequency interference, 90

## S

Safety precautions, 5  
Sensor location, 94  
Shock and vibration, 12  
Sonar Head  
  Installation, 29

- location, 32
- Specifications, 21
- Subsea vehicle, Installation, 40
- Supply conditions, 6
- System diagram
  - 120 degrees, 3
  - 150 degrees, 4
- System overview, 2

## **T**

- Technical specifications, 21
- Temperature protection, 20
- Tools, 5
- Transmit Transducer, location, 32
- Transmit transducer, Installation, 29







EM 2000  
Index / Base version

EM 2000  
Index / Base version

EM 2000  
Index / Base version

EM 2000  
Index / Base version