



KONGSBERG

Instruction Manual

SPT and MPT x3x series

SSBL Positioning Transponder (SPT)

Multifunction Positioning Transponder (MPT)

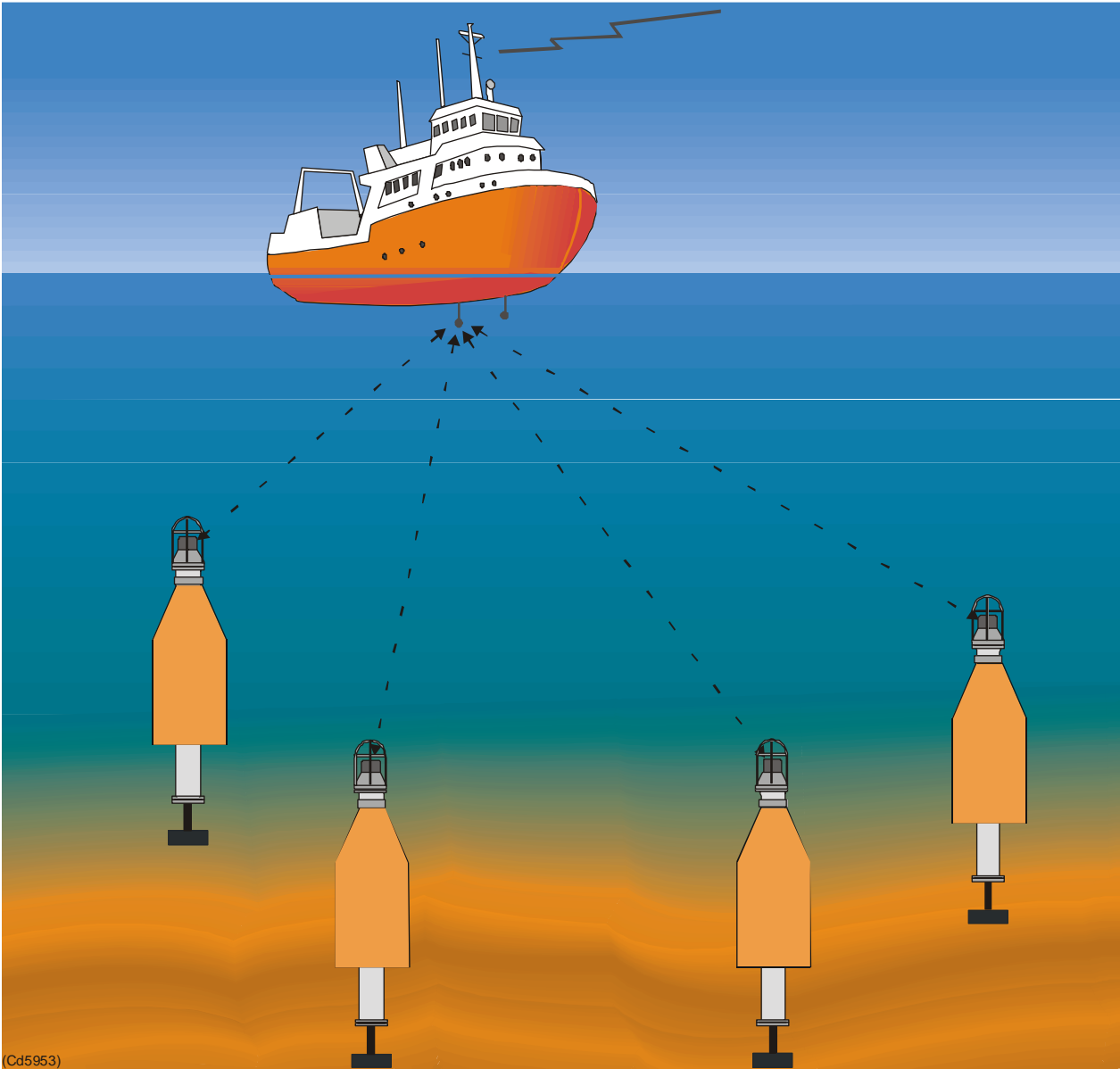

(Cd5953)

SPT and MPT x3x series

*SSBL Positioning Transponder (SPT)
Multifunction Positioning Transponder (MPT)*

Warning

Due to safety rules, the safety information for transponder and transponder battery must be read before handling transponders or separate transponder batteries. Refer to:
- Safety information for transponder and transponder battery chapter on page 138.

Document history

Rev	Date	Written by	Checked by	Approved by
L	20.09.09	GM	SER	JEF
Updated layout. Reorganised information - transponder and battery delivered as separate units. Implemented battery weight. Removed MPT 331/DuBSi. Minor corrections in the text.				

Copyright

© 2009 Kongsberg Maritime AS. All rights reserved. The information contained in this document remains the sole property of Kongsberg Maritime. No part of this document may be copied or reproduced in any form or by any means, and the information contained within it is not to be communicated to a third party, without the prior written consent of Kongsberg Maritime.

Disclaimer

Kongsberg Maritime endeavours to ensure that all information in this document is correct and fairly stated, but does not accept liability for any errors or omission.

Warning

The equipment to which this manual applies must only be used for the purpose for which it was designed. Improper use or maintenance may cause damage to the equipment and/or injury to personnel. The user must be familiar with the contents of the appropriate manuals before attempting to operate or work on the equipment. Kongsberg Maritime disclaims any responsibility for damage or injury caused by improper installation, use or maintenance of the equipment.

Support

All Kongsberg Maritime products:
Phone 24 hour: +47 815 35 355
E-mail: km.support@kongsberg.com

HiPAP, HPR, ACS and Transponders:
Phone 24 hour: +47 992 03 808
E-mail: km.support@kongsberg.com

Kongsberg Maritime AS

Strandpromenaden 50
P.O.Box 111
N-3191 Horten,
Norway

Telephone: +47 33 02 38 00
Telefax: +47 33 04 47 53
www.kongsberg.com
E-mail: subsea@kongsberg.com



KONGSBERG

Contents

ABOUT THIS MANUAL	1
Manual contents	1
Abbreviations	1
BASIC TRANSPONDER INFORMATION	2
How to handle a transponder	3
General transponder description	4
Transponder identification	4
Applications	6
SPT specific applications	6
MPT specific applications	6
HPR and HiPAP compatibility	6
Available transponders	7
Transponder model identification principles	9
Model name	9
Model number	9
Options	9
Housing material	10
Transponder models description	11
Basic models	11
Versions	11
Beam patterns	14
Auxiliary equipment	15
TECHNICAL SPECIFICATIONS	16
Source level and receiver sensitivity	16
Common specifications	17
Release units	17
Version/DT	17
Sensors	17
Version/R and /DTR	18
Version/RspSx 110 Vac	18
Version/DTDuB and DTRDuB	18
Stainless steel transponders	19
Version/I	19
Version/II	19
Version/SU	19
Floating collars	20
Guiding collars	20
Mounting brackets	20
Battery weight	21
Lithium battery label	22
External connectors	23

TRANSPONDER SET-UP AND OPERATION	26
System set-up	27
Pre-deployment checks	27
Pigtail	27
Transponder in operation	28
Transponder not in operation	29
Mounting	29
Deployment	29
Ready for operation	29
Positioning of a transponder	30
Operation	30
Transponder in use	30
Sensor information	30
DT sensors	30
Inclinometer sensors	31
Responder function	32
Recovery	32
Storage	33
Release mechanism - stainless steel models	34
Operation	34
Setting the release mechanism	34
Release mechanism - aluminium models	35
Setting the release mechanism	37
Storage	38
BATTERIES	39
Battery layout	40
Battery specification	40
Battery replacement	40
Battery capacity	41
Battery lifetime at operation	42
Lithium battery packs	42
Lithium battery storage	44
Alkaline battery pack	45
Alkaline battery storage	46
Rechargeable battery pack	47
How to connect the transponder battery	48
Important information	48
Procedure	49
How to mount the transponder battery	50
How to replace a transponder battery	51
Procedure	51
TRANSPONDER CONFIGURATION	53
Frequency bands	54
Acoustic telemetry - basics	54

Switch settings - basics	54
HPR 400/HiPAP channels	55
HPR 400 system	55
HiPAP system	55
Acoustic coding principle	55
HPR 400 channels and positioning frequencies	56
HPR 300 channels	58
HPR 300 command function	58
HPR 300 frequencies and switch settings	58
Responder and external power functions	61
Double inclinometer	61
MAINTENANCE	62
Preventive maintenance	62
Testing the transponder	62
Dismantling the transponder	63
Replacement of circuit boards	65
Rx board, Tx board and Microcontroller board	65
Rx-amplifier matching board and motherboard	66
Replacement of the transducer	66
SPT 133 unit, the MPT 339 and MPT 139 series	66
SPT 331 and MPT 331 series	67
Remove the bottom end cap / release unit	67
Transponder assembly	68
Transducer handling	69
Source level adjustment	69
SPT/MPT 110 Vac transponder-power module	70
MAIN PARTS	71
Transducer	73
Housing	73
Bottom end cap / Release unit	73
Circuit boards	74
Transmitter board (Tx)	75
Receiver board (Rx)	76
Rx amplifier matching board	77
Microcontroller board	78
Switches	78
Motherboard	79
AUXILIARY EQUIPMENT	80
Anchor-weight	80
Floating rope	80
Auxiliary equipment supplied by Kongsberg Maritime	80

SPARE PARTS	85
Introduction	85
Codes used	85
Accessories	87
Sensors	88
Batteries	88
SPT 331/St transponder	89
SPT 331/R-St transponder	91
SPT 331/I-St transponder	95
SPT 331/II-St transponder	97
SPT 331/RspSx 110 Vac-St transponder	102
SPT 331 basic transponder	104
SPT 331/R transponder	106
SPT 331/RspSx 110 Vac transponder	108
SPT 133/RspSx 110 Vac SU-St transponder	110
Transducer unit	112
MPT 339/St transponder	114
MPT 339/DTR-St transponder	116
MPT 339/DTRspSx 110 Vac-St transponder	118
MPT 339/DTR transponder	120
Magnetic release mechanism	122
MPT 339/DT transponder	123
MPT 331/DTDuB-St transponder	124
MPT 331/DTRDuB-St transponder	126
MPT 331/DTDuB transponder	127
MPT 331/DTRDuB transponder	129
MPT 139/St transponder	130
MPT 139/DT-St transponder	132
MPT 139/DTR-St transponder	134
MPT 139/DTRspSx 110 Vac-St transponder	136
SAFETY INFORMATION FOR TRANSPONDER AND TRANSPONDER BATTERY	138
Identification of the products and company	139
Product name	139
Range of battery products	139
Company address	139
Emergency contact	139
Composition and information on ingredients	140
Battery chemistry	140
Battery weight and lithium content	140
Battery cell manufacturers/types	140
Battery design	141

Hazards identification	141
Danger of explosions	141
Noxious gases	142
First-aid measures	142
Fire-fighting measures	142
Accidental release measures	143
Handling and storage	143
Recovering a "functioning" transponder	143
Recovering a "failing" transponder	144
Handling a heated or self-heated transponder	144
Handling a transponder if relief valve opens	145
Opening a transponder with defect/possible defect battery	145
Opening a "functioning" transponder	145
Handling heated or warm separate battery	146
Handling transponders and separate transponder batteries in case of an external fire	146
Storage	146
Exposure controls and personals protection	147
Physical and chemical properties	147
Stability and reactivity	147
Toxicological information	148
Ecological information	148
Disposal considerations	148
Transport information	149
Regulatory information	149
Other information	149
DRAWING FILE	150
Drawings	150
INDEX	176

ABOUT THIS MANUAL

Manual contents

This manual describes all the Kongsberg Maritime SPT and MPT transponders, for deep water use - 3000 m rated.

It provides general information, technical specifications, operating instructions, maintenance procedures and battery information and safety procedures. It also includes spare parts lists and outline dimension drawings for each of the transponder units.

Abbreviations

BOP	Blow Out Preventer
HiPAP	High Precision Acoustic Positioning
HPR	Hydroacoustic Position Reference
LBL	Long Base Line
LF	Low Frequency
MF	Medium Frequency
MPT	Multifunction Positioning Transponder
N/A	Not Applicable
NC	Not Connected
ROV	Remotely Operated Vehicle
SPT	SSBL Positioning Transponder
SSBL	Super-Short Base Line
TP	TransPonder

BASIC TRANSPONDER INFORMATION

The purpose of this chapter is to provide an overall description of the transponders included in this manual.

Topics

- *How to handle a transponder on page 3*
- *General transponder description on page 4*
- *Transponder identification on page 4*
- *Applications on page 6*
- *HPR and HiPAP compatibility on page 6*
- *Available transponders on page 7*
- *Transponder model identification principles on page 9*
- *Transponder models description on page 11*
- *Beam patterns on page 14*
- *Auxiliary equipment on page 15*

How to handle a transponder

Each transponder is delivered with separate battery. Standard battery is a Lithium battery.

Warning

***Due to safety rules, the transponder must be handled with care. Refer to:
- Safety information for transponder and transponder battery chapter on page 138.***



Figure 1 Special precautions to avoid personnel injury

General transponder description

The SPT and MPT x3x transponder series are designed for use with the Kongsberg Maritime HiPAP and HPR systems. The following are available:

- SPT 331 transponder series
- SPT 133 transponder unit
- MPT 339 transponder series
- MPT 331 transponder series
- MPT 139 transponder series

→ *Examples of the transponders are shown in figure on page 5.*

All models have an acoustic telemetry link for command and data transfer.

The transponder unit is designed with a modular construction such that the transducer, transponder electronics, battery pack and options (where applicable) can be replaced individually.

A transponder is normally a self-contained unit, its power being provided from an internal battery pack.

All units are designed for ROV manipulator handling.

The transponder may be secured to a subsea structure using mounting brackets, or fitted with an anchor weight and floating collar for location on the open seabed.

Transponder identification

An identification clamp ring is tightened around the transponder body. This ring is engraved with:

- Transponder name
- Transponder registration number
- Unique serial number
- Frequency channel
- Type of battery

The figure shows an identification clamp ring for a transponder that uses channel 57 and includes a lithium battery. Name and serial number is engraved on the other side - see illustrations in the *Spare parts* section.

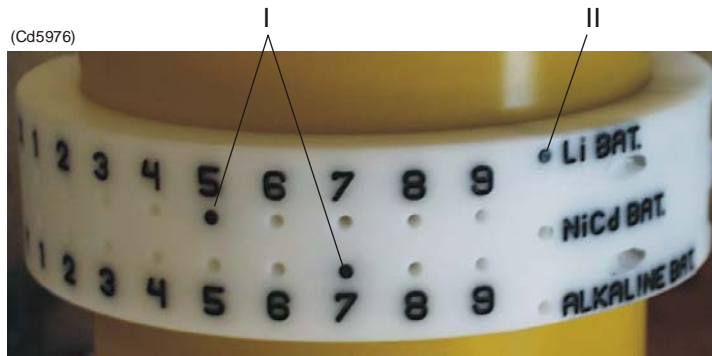

Figure 2 Example of identification clamp ring

If the TP configuration and battery is changed, the channel number (I) and the type of battery (II) can be altered by setting pegs into different holes in the clamp.

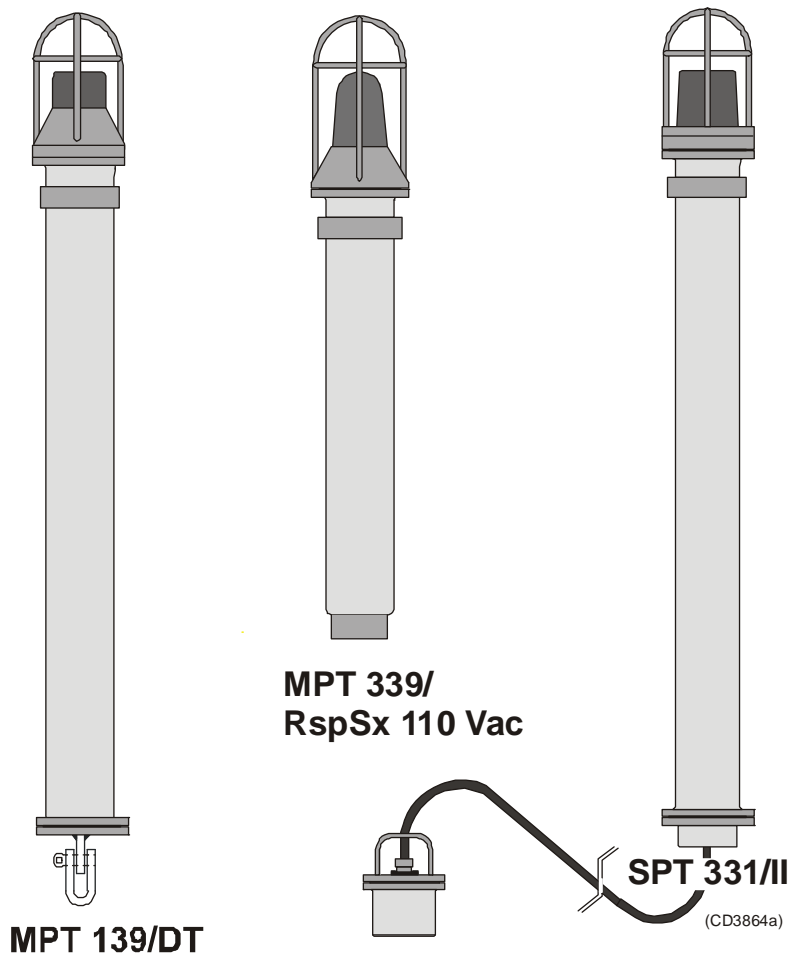

Figure 3 Examples of SPT and MPT transponders

Applications

On interrogation, all models will reply with either a single- or a multi-pulse response. The response information depends on the application. All SPT and MPT models can be used in the following applications:

- SSBL positioning
- Acoustic release
- Telemetry of sensor data
- Depth and temperature measurement
- Responder function

SPT specific applications

The following application can be used with the SPT only:

- Inclination measurement
- Differential inclination measurement

MPT specific applications

The following applications can be used with the MPT only:

- LBL positioning
- Self positioning
- Range measuring

HPR and HiPAP compatibility

All the 33x transponders are compatible with the Kongsberg Maritime HiPAP systems and HPR 400 MF.

The 13x transponders are compatible with the Kongsberg Maritime HPR 400 LF system.

Available transponders

This manual covers the following transponders:

Transponder series	Model	Housing material	
SPT 331			
	SPT 331/St	Basic unit	Stainless steel
	SPT 331	Basic unit	Aluminium
	SPT 331/R-St	Release	Stainless steel
	SPT 331/R	Release	Aluminium
	SPT 331/I-St	Inclinometer	Stainless steel
	SPT 331/II-St	Two sets of Inclinometer, differential measurement	Stainless steel
	SPT 331/RspSx110 Vac-St	Responder with Short tube, backup battery and 110 Vac power supply	Stainless steel
	SPT 331/RspSx 110 Vac	Responder with Short tube, backup battery and 110 Vac power supply	Aluminium
SPT 133			
	SPT 133/RspSx 110 Vac SU-St	Responder with Short tube, backup battery, split transducer and 110 Vac power supply	Stainless steel
MPT 339			
	MPT 339/St	Basic unit	Stainless steel
	MPT 339/DT	Depth, Temperature	Aluminium
	MPT 339/DTR-St	Depth, Temperature and Release	Stainless steel
	MPT 339/DTR	Depth, Temperature and Release	Aluminium
	MPT 339/DTRspSx 110 Vac-St	Responder with Short tube, backup battery and 110 Vac power supply	Stainless steel

Transponder series	Model		Housing material
MPT 331			
	MPT 331/DTDuB-St	Depth and Temperature with Dual Beam	Stainless steel
	MPT 331/DTRDuB-St	Depth, Temperature and Release with Dual Beam	Stainless steel
	MPT 331/DTDuB	Depth and Temperature with Dual Beam	Aluminium
	MPT 331/DTRDuB	Depth, Temperature and Release with Dual Beam	Aluminium
MPT 139			
	MPT 139/St	Basic unit	Stainless steel
	MPT 139/DT-St	Depth and Temperature	Stainless steel
	MPT 139/DTR-St	Depth, Temperature and Release	Stainless steel
	MPT 139/ DTRspSx 110 Vac-St	Depth, Temperature, Responder with Short tube, backup battery and 110 Vac power supply	Stainless steel

Transponder model identification principles

The transponder name consists of the model name, the model number and any options included.

The name contains three letters followed by three digits. The letters after the numbers describe the option (see example below).

Model name

SPT = SSBL Positioning Transponder.

MPT = Multifunction Positioning Transponder.

Model number

The three digits describe:

Digit 1: frequency band

Digit 2: depth rating

Digit 3: beamwidth

The following are available:

1st digit	2nd digit	3rd digit
Frequency band	Depth rating	Transducer beamwidth
1 = 12 kHz 3 = 30 kHz	3 = 3000 m	1 = $\pm 15^\circ$ 3 = $\pm 30^\circ$ 9 = $\pm 90^\circ$

Options

The combination of letters after the number describes the options contained in the unit. The following options are available:

DT	Depth and Temperature sensors
R	Release mechanism
RspSx110 Vac	<u>R</u> esponder, <u>S</u> hort tube, small backup battery and power supply
I	Inclinometer (one unit)
II	Inclinometer - the unit is divided into two containers (differential inclination)
DuB	Dual Beam

S	Split housing and transducer
U	Unlisted function which is custom specified ⇒ <i>See unit (reg. no 102-210480) and description on page 12.</i>

Housing material

Aluminium is the standard housing material. If Stainless steel is used, the abbreviation “St” is added to the transponder name (see example below).

Example: **MPT 339/DTR-St**

The example given (MPT 339/DTR-st) therefore indicates that the transponder unit is an Multifunction Positioning Transponder, operating in the 30 kHz band, rated to 3000 meters depth, with a $\pm 90^\circ$ beamwidth, and including the Depth and Temperature sensors and Release mechanism. The housing material is Stainless steel.

Transponder models description

Basic models

SPT 331

The SPT 331 can only operate as an MF SSBL transponder to provide positional information. It is equipped with a $\pm 15^\circ$ beamwidth transducer. All SPT models are based on this basic model.

SPT 133

The SPT 133 can only operate as an LF SSBL transponder to provide positional information. It is equipped with a $\pm 30^\circ$ beamwidth transducer.

MPT 339

The MPT 339 transponder operates as either an MF SSBL or LBL transponder to provide positional information. It is equipped with a $\pm 90^\circ$ beamwidth transducer. All MPT 33x models are based on this basic model.

MPT 139

The MPT 139 transponder operates as either an LF SSBL or LBL transponder to provide positional information. It is equipped with a $\pm 90^\circ$ beamwidth transducer. All MPT 13x models are based on this basic model.

Versions

/DT

The **Depth and Temperature** (DT) transponder is equipped with pressure and temperature sensors to measure:

- The depth at the position where the unit is moored.
- The temperature in the surrounding water.

Note

In the HPR 300 system only depth is obtainable.

/R

The **Release mechanism (R)** transponder is a recoverable unit fitted with an automatic release mechanism and floating collar. This detaches the anker weight on request from the HPR / HiPAP system. Once the transponder has been released, it will float to the surface where it can be recovered.

You can reset the release mechanism at the surface, and you can use the same unit many times in different areas. The anchor weight will be lost during the release operation, so it will require replacement every time.

/RspSx 110 Vac

The **Responder with Short tube and small backup battery (RspSx 110 Vac)** transponder is a combined responder and transponder.

→ *The responder function is as described in the paragraph above.*

/SU

The **Split housing and transducer (SU)** transponder is a combined responder and transponder.

The unit has separate housing (electronics unit) and transducer. The transducer has a 5 m long cable, to connect it to the housing. The housing unit has an internal relay that is wired to the housing external connector.

The relay is activated by a command from the HPR/HiPAP system. The relay is active for 5 seconds.

/I

The **Inclinometer (I)** transponder is equipped with one set of inclinometers set at 90° to each other. It is used to measure and monitoring the angles of structures, such as:

- Riser angle measurement on oil platforms
- Monitoring underwater pipelines
- Template levelling

/II

The **double Inclinometer (II)** transponder is a differential inclinometer transponder. It is equipped with two sets of inclinometers, and comprises two separate units. One set of inclinometer is mounted within the transponder, and the other as a separate unit. The two units are interconnected by 9 metre of cable. The X and Y inclination angles transmitted are the differences between the inclination angles of the two units.

/DuB

The **Dual Beam** (DuB) transponder works as a dual beam transponder. It is used in LBL deep water positioning, and is equipped with a $\pm 15^\circ$ beamwidth transducer. It operates in the following two modes:

- Calibration
- Position

The array calibration is performed using a “doughnut-shaped” beam. When the calibration is completed, this beam is switched off, and the transponder is then operating in the position mode, with a $\pm 15^\circ$ beamwidth upwards.

Beam patterns

The figure shows beam pattern for the different transducer types;
 $\pm 90^\circ$ and $\pm 15^\circ$. The beam pattern shows the transmit/receive sensitivity in the different directions.

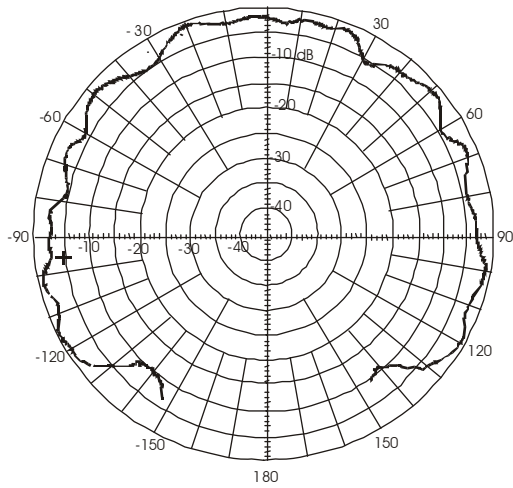

MPT 339 series
 Source level = 195 dB

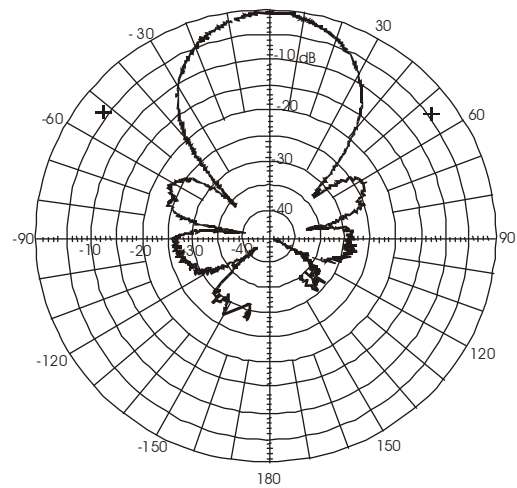

SPT 331 series
 MPT 331/DuB vertical
 Source level = 206 dB

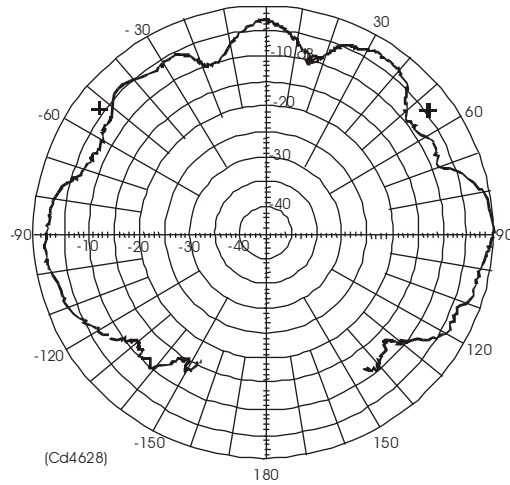

MPT 331/DuB horizontal
 Source level = 190 dB

Figure 4 Examples of beam pattern

Auxiliary equipment

Various types of auxiliary equipment are used to mount a transponder in a correct and secure way. The most common types are:

- Floating collar on page
- Anchor-weight
- Mounting brackets
- Mounting collars

→ *For auxiliary equipment supplied by Kongsberg Maritime, refer to page 80.*

TECHNICAL SPECIFICATIONS

This chapter lists the main technical specifications.

Topics

- *Source level and receiver sensitivity on page 16*
- *Common specifications on page 17*
- *Release units on page 17*
- *Version/DT on page 17*
- *Version/R and /DTR on page 18*
- *Version/RspSx 110 Vac on page 18*
- *Version/DTDuB and DTRDuB on page 18*
- *Version/I on page 19*
- *Version/II on page 19*
- *Version/SU on page 19*
- *Floating collars on page 20*
- *Guiding collars on page 20*
- *Mounting brackets on page 20*
- *External connectors on page 23*

Related topics

- *Batteries on page 39*
- *Lithium battery label on page 22*

Source level and receiver sensitivity

Model series	Source level - max (4 steps of 3 dB)	Receiver sensitivity HIGH / LOW (2 steps)
MPT 339	195	100 / 106
MPT 331/DuB	Vertical: 206 Horizontal: 190	100 / 106
SPT 331	206	100 / 106
MPT 139	190	100 / 106
SPT 133	200	100 / 106

Common specifications

The technical details given in this paragraph are common for all the transponder types described in this manual.

Technical details	Aluminium models	Stainless steel models
Maximum depth rating	3000 meters	3000 meters
Housing material	Aluminium	Stainless steel
Flange and transducer head	Aluminium/ polyurethane	Stainless steel
Operation temperature	0° to +30°C	0° to +30°C

→ *Outline dimension and weight, refer to page 150.*

Release units

As in common specifications, except:

Technical details	Aluminium models	Stainless steel models
Weight in air / water	2 kg / 0.5 kg	3 kg / 0.7 kg
Length	221 mm	approx. 190 mm
Max diameter	138 mm	138 mm

Version/DT

Sensors

As in common specifications (both Aluminium and Stainless steel), except:

Max depth on /DT - sensors	3000 m
- Resolution	0.1 m
- Accuracy (FS)	< 0.1%
Temperature range on /DT - sensors	- 5° to + 30° C
Resolution	0.1° C
Accuracy	0.2° C

→ *Outline dimension and weight, refer to page 150.*

Version/R and /DTR

As in common and version/DT specifications, except:

Technical details	Aluminium models	Stainless steel models
Release; lift / buoyancy	max. 250 kg	max. 140 kg
Separate release battery	N/A	1000 releases

→ *Outline dimension and weight, refer to page 150.*

Version/RspSx 110 Vac

As in common specifications, except:

Technical details	Aluminium models	Stainless steel models
Maximum power consumption 110 Vac	7.5 W	7.5 W
Backup Lithium battery quiescent lifetime	130 days	130 days
External connector type	7-pins Gisma plug 10.00.2.07.1.10	7-pins Gisma plug 10.00.2.07.1.10

→ *Outline dimension and weight, refer to page 150.*

Version/DTDuB and DTRDuB

As in common specifications, except:

Technical details	Aluminium models	Stainless steel models
Transducer beamwidth Dual Beam (DuB)	Vertical: ± 15 deg Horizontal: ± 15 deg	Vertical: ± 15 deg Horizontal: ± 15 deg

→ *Outline dimension and weight, refer to page 150.*

Stainless steel transponders

The models described in this section are only available in Stainless steel.

Version/I

As in common specifications, except: One set of inclinometers.

Maximum detectable angles:	
HPR 300 channels	± 15 deg
HPR 400 channels	± 60 deg
Resolution:	
HPR 300 channels - pulse position telemetry	0.25 deg
HPR 400 channels - pulse position telemetry	0.1 deg
HPR 400 channels - full telemetry	0.02 deg
Accuracy, standard sensors	0.25 deg

→ *Outline dimension and weight, refer to page 150.*

Version/II

As in common specifications and model/I, except: Two units, each with one set of inclinometers.

→ *Outline dimension and weight, refer to page 150.*

External connector type	7-pins Gisma plug 10.00.2.07.1.10
Interconnection cable	maximum 9 m

Version/SU

As in common specifications, except:

Relay ("release")	active for 5 sec
Transducer unit:	
Type	Kongsberg Maritime LF standard
Material	(aluminium)-bronze
Beamwidth	approx. 60 deg. at -3 dB
Cable connector type	7-pins Gimsa plug 10.00.2.07.1.10

→ *Outline dimension and weight, refer to page 150.*

Electronic unit:	
External top connector type	7-pins Gimsa plug 10.00.2.07.1.10
External bottom connector type	12-pins Gimsa plug 10.00.3.12.1.10

→ *Outline dimension and weight, refer to page 150.*

Floating collars

Technical details common for both types of floating collars:

Depth rating	3000 m
Colour	orange

- **Aluminium transponder** - *Outline dimension and weight, refer to page 150.*
- **Stainless steel transponder** - *Outline dimension and weight, refer to page 150.*

Guiding collars

Technical details common for both types of guiding collars:

Depth rating	3000 m
Material	Polyethylene
Colour	Black/White

- **Aluminium transponder** - *Outline dimension and weight, refer to page 150.*
- **Stainless steel transponder** - *Outline dimension and weight, refer to page 150.*

Mounting brackets

No technical data available. Depends on type of mounting brackets used.

Battery weight

Lithium (L) (standard)	see table on page 22
Alkaline (A)	8.0 kg
Rechargable (N)	8.0 kg

Lithium battery label

All Lithium batteries have the following label:

(The serial number and production date is specified for each battery.)

Lithium Battery Pack

Serial no: _____ Prod.date : _____

	PART NUMBER	BATTERY TYPE	BATTERY WEIGHT (kg)	LITHIUM CONTENT (g)
	290-089501	L10/36 (15/20)	4,3	175
	290-101665	L10 /36(18/30)	5,6	240
	290-103053	L10/36(15/40)	6,6	235
	290-089505	L10/36(36/60)	11,7	480
	290-102726	L10/40(3/11)	1,7	70
	290-210845	L10/40(3/11)	1,7	70
	290-089010	L10/21(6/12)	2,2	90
	290-082380	L10/21(6/48)	6,7	270
	290-089592	L10/5(12/42)	6,5	228
	290-222071	L10/50(27/28)	6,6	247
	290-083530	L50/10/24	10	438
	290-219492	L24 (98)	11	490
	290-062447	L50	4,3	175
	290-080718	L80	6,8	280
	325902	L14.4 (48)	5,9	183

CAUTION !

This is a **lithium thionyl chloride battery**. Note that special precautions are required:

- *This battery must NOT be recharged, forced open or disposed off in fire.*
- *Refer to Safety Data Sheet, reg.no.859-164733*

Manufacturer:
Kongsberg Maritime AS
Strandpromenaden 50
N-3190 Horten, Norway
www.kongsberg.com

(Cd30136)

External connectors

The following transponders are fitted with an external connector:

- **Models including the responder and the external power (110 Vac) functions** - these models are delivered with a pigtail.
- **SU model** (separate transducer and housing (electronics unit)) - this model is delivered with a pigtail.
- **The double inclinometer model** - this model is delivered with an interconnection cable.

The description and layout of the connectors and a pigtail are presented in the following paragraphs.

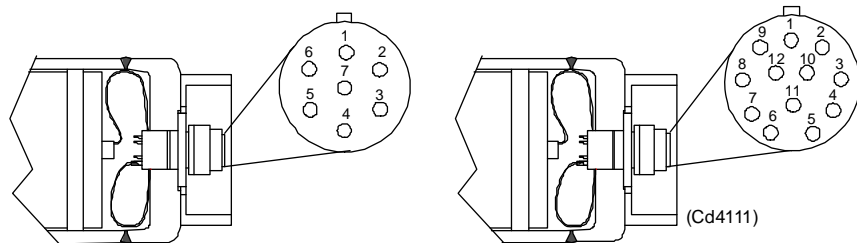

Figure 5 A 7 pin and a 12 pin external connector - layout

Caution

Take care when wiring the unit. Incorrect wiring may cause irreparable damage.

External connector for/RspSx 110 Vac

The connector for the responder and the external power function is a 7 pins connector.

→ *The connector pin no. and function refer to table 1.*

Pin no.	Function
1	External trigger line
2	External trigger GND
3	Note*
4	Note*
5	External 110 Vac
6	External 110 Vac
7	GND

Table 1 Standard external connector

Note

* Linked in the pigtail plug (pin no 3 and 4) to apply 10 V from the battery to the electronics.

External connector for/II - interconnection

Both units of the double inclinometer transponder are provided with a 7 pins connector for interconnection.

→ The connector pin no. and function refer to table 2.

Pin no.	Function
1	External trigger line
2	GND
3	Pol Y
4	Pol X
5	Inclinometer Y
6	Inclinometer X
7	External 10 V

Table 2 Double inclinometer external connector

External connector for/RspSx 110 Vac SU

The RspSx 110 Vac SU model has the following two (2) external connectors:

- 1 **a 7 pins connector at the top** - for units interconnection. The connector pin no. and function are shown in table 3
- 2 **a 12 pins connector at the base** - to incorporate the connections to the relay terminals.

→ The connector pin no. and function refer to table 4.

Pin no.	Function
1	TD, Narrow - Note *
2	NC
3	NC
4	TD, Narrow - Note *
5	TD, Common
6	NC
7	NC

Table 3 RspSx 110 Vac SU top external connector

Note **Linked in the external connector (pin no 1 and 4).*

Pin no.	Function
1	Ext. trig
2	Trig. gnd
3	Note*
4	Note*
5	110 Vac
6	110 Vac
7	GND
8	Relay +1
9	Relay 2
10	NC
11	NC
12	NC

Table 4 RspSx 110 Vac SU base external connector

Note **Linked in the pigtail plug (pin no 3 and 4) to apply 10 V from the battery to the electronics.*

TRANSPONDER SET-UP AND OPERATION

This chapter contains a brief overview of how to set-up and operate a transponder.

The transponders are designed for operation in water only.

Caution

The transponder unit and the battery are delivered as separate units. The battery must be mounted onto the transponder chassis and connected before deployment.

Topics

- *System set-up on page 27*
- *Pre-deployment checks on page 27*
- *Pigtail on page 27*
- *Mounting on page 29*
- *Deployment on page 29*
- *Ready for operation on page 29*
- *Positioning of a transponder on page 30*
- *Operation on page 30*
- *Transponder in use on page 30*
- *Sensor information on page 30*
- *Responder function on page 32*
- *Recovery on page 32*
- *Storage on page 33*
- *Release mechanism - stainless steel models on page 34*
- *Release mechanism - aluminium models on page 35*

Related topics

- *Mounting the battery on page 50*
- *Connecting the battery on page 48*
- *Replacement of the battery on page 51*

System set-up

All transponders are preset by the manufacturer. The channel setting may be changed if required. This can be done as follows:

- Use of internal switches, or
- use of acoustic telemetry from a HiPAP or aHPR 400 system. (A HPR 300 system can not send telemetry for this purpose.)

For information about set-up of a transponder, refer to *APOS Instruction manual /APOS on-line help*.

Pre-deployment checks

Before you deploy the transponder, you must:

- 1 Check that the battery contains sufficient power for the proposed operation.
- 2 Perform a visual inspection of the transponder.
- 3 Perform a functional check to ensure it will operate correctly once it has been positioned on the seabed.
 - Ensure the transponder replies to the correct interrogation frequency.

The functional check can be performed as follows:

Transponder in water - use the APOS function check. When checking, lower the transponder on a rope over the vessel's side.

→ *Refer to the APOS Instruction manual / APOS on-line help.*

Transponder on deck - use the Transponder Test and Configuration Unit (TTC 400).

Note

The TTC 400 can only be used for transponders using the 30 kHz frequency band.

→ *Refer to the TTC 400 Instruction manual / TTC 400 Quick Reference Guide.*

Pigtail

For all transponders that required external connection, a pigtail is provided. To achieve correct operation of the transponder, the following information is of great importance.

For some transponders, the pigtail is linked in the pigtail plug to apply 10 V from the battery to the electronics.

→ *Refer to page 23 for details.*

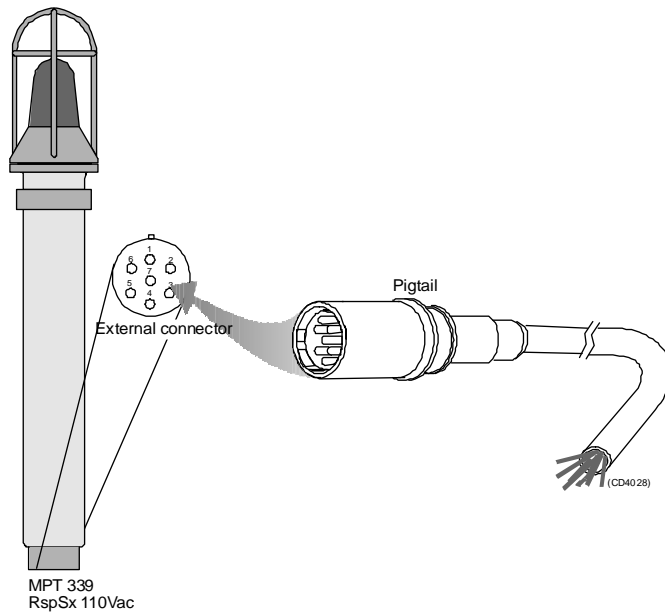

Figure 6 Example of external connector with pigtail

Transponder in operation

Caution

The pigtail must always be connected. If it is removed, the transponder will not work at all. This applies for all types of external connections.

Caution

If for any reason the pigtail must be removed, it must be replaced with a dummy connector. If not, the transponder will not work at all. Remember that pin no 3 and 4 in the connector must be linked!

Caution

*When the pigtail has been disconnected from the transponder, wait at least 20 seconds before reconnecting it.
When reconnecting, make the connection firmly and decisively.*

Transponder not in operation

If 110 V is not present, (when the transponder is not in operation) you are advised to disconnect the pigtail to save battery power.

Mounting

A transponder may be secured to a subsea structure using mounting brackets, or fitted with an anchor weight and floating collar for location on the open seabed.

→ Refer to chapter on page 80.

Deployment

Caution

During deployment prevent the transponder from slamming against other solid objects.

Caution

When you deploy the transponder, the anchor-weight must be lifted separately from the transponder. DO NOT attempt to lift both the transponder and the anchor-weight via the transponder - the transducer cage is only approved for lifting the transponder and the floating collar.

When you deploy the transponder:

- The unit must be positioned with the transducer upright.
- Ensure a clear line of sight between the transponder's head and the ship's transducer.
- The transponder requires an anchor-weight / brackets to hold the transponder securely in position on the seabed / ROV.
→ Refer to section on page 80.
- The transponder release mechanism must be attached to a shackle. The shackle will ensure a smooth release of the transponder when requested by the operator.

Ready for operation

Once deployed, the transponder is ready for operation. The sensors in your application will respond to requests from the HPR / HiPAP system, when they are enabled using telemetry.

Positioning of a transponder

Positioning of a transponder can be done in two ways:

- 1 The normal way is that the topside send a request to the transponder, the transponder answer the request after a given time delay.
 - 2 The other way is with the transponder in beacon mode, then the transponder acts as an acoustic lighthouse. It transmits pulses regularly (with a given Pulse Repetition Interval) without being interrogated.
- For more information, refer to the APOS on-line help.

Operation

The operation of a transponder is performed at the HiPAP / HPR topside Operator Station. For information regarding operation, refer to *APOS Instruction manual / APOS on-line help system*.

Transponder in use

Caution All personnel that handle transponders must know the transponder's status:

'Functioning' - 'Failing' - 'Unknown'

Caution A Transponder with unknown status, must be handled as a transponder that is failing. For more information:
→ Refer to "Handling" on page 143.

Sensor information

DT sensors

No special preparations for the user.

Inclinometer sensors

On both the /I and the two /II transponder units, the front direction is marked. This is illustrated in figure 7 and 8. The inclinometers' X and Y-axes are referenced to this mark.

- The Y-axis is parallel to the mark and perpendicular to the longitudinal axis of the unit.
- The X-axis is perpendicular to both the longitudinal axis and the Y-axis.

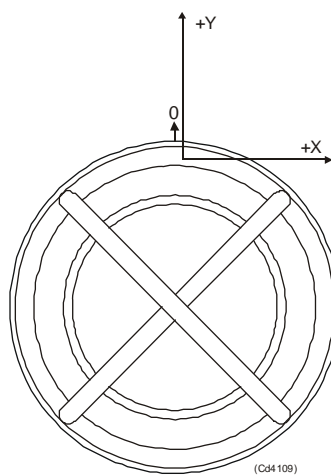

Figure 7 Top view of the inclinometer transponder - showing the front direction

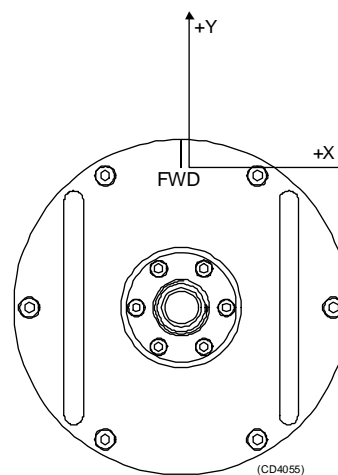

Figure 8 Top view of the double inclinometer separate unit - showing the front direction

Note *When deploying the II transponder, the two units must be positioned in the same direction (referring to the top markings).*

Responder function

To activate this function, the transponder must be connected directly to the HiPAP / HPR system via a cable.

- The responder function is automatically initiated by the presence of a valid “Trigger” pulse. When you provide a valid trigger pulse from the HiPAP / HPR system, the responder will reply on the previously selected channel.

For the MPT 139/DTRspSx model:

- If a HPR 300 system is used, activate the ENABLE SSBL TP function.

Recovery

After recovery, wash the unit thoroughly in fresh water to dissolve any salt deposits and clean off any sand or silt. If available, a high pressure hose may be used.

→ Refer to “Handling” on page 143.

Aluminium transponder release:

Caution *It is very important that the release unit (if fitted) is washed properly. Salt deposits, may prevent the mechanical part’s mobility.*

Storage

→ Refer to “Storage” on page 143.

Aluminium transponder release:

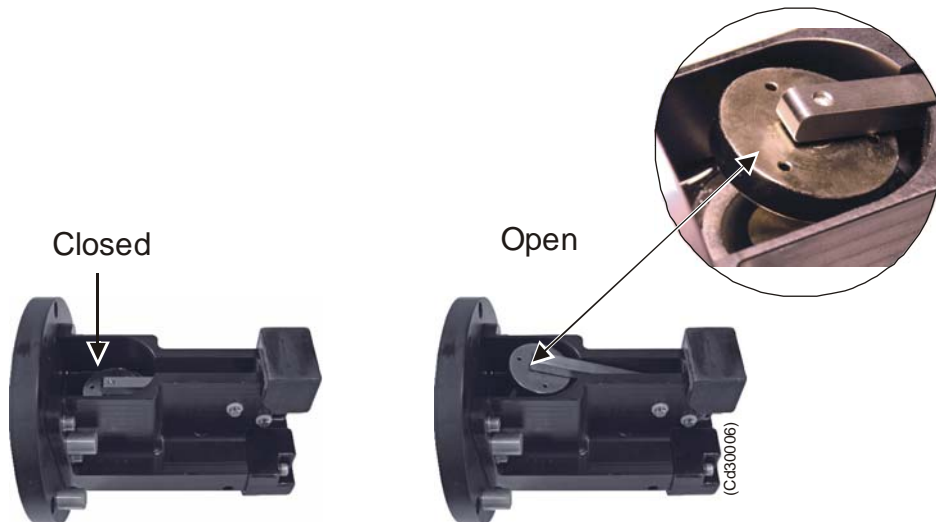

Figure 9 Release unit - aluminium transponder

→ For information about manual release, refer to page 36.

Release mechanism - stainless steel models

Operation

The release function is initiated at the HiPAP / HPR system. When activated, the following will occur:

- Power is applied to the DC motor within the unit.
- The locking shaft rotates one turn, and is stopped by a micro-switch when it has completed the revolution.
 - One revolution takes 15 seconds, and within this time the hook will have been released.
- The transponder will float to the surface.

Note

Once the transponder reaches the surface, it can be lifted from the water by attaching a hook / rope to the transducer cage.

Setting the release mechanism

To reset the release mechanism:

- 1 Ensure the anchor shackle and rope are located in the jaws (1).
 - Do not use a chain. A chain can cause corrosion.
- 2 Snap the hook back onto position (2) and (3).

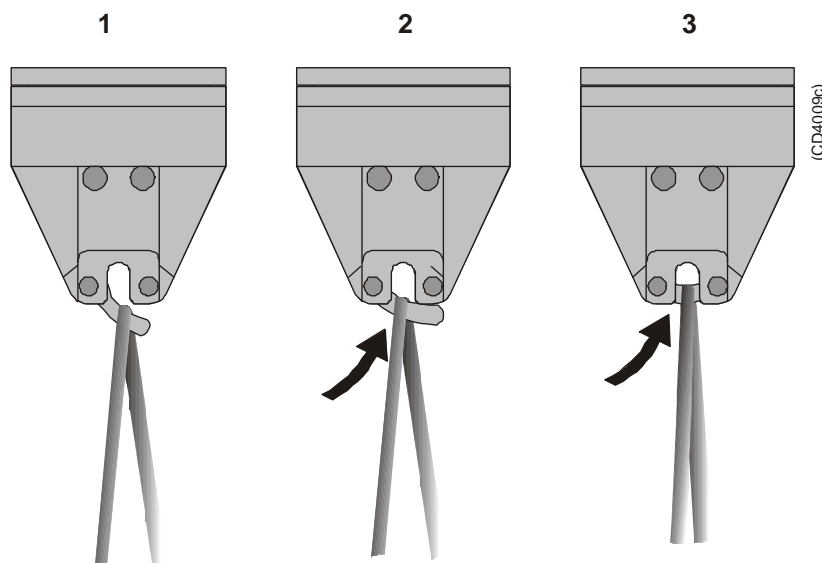

Figure 10 Setting the release - stainless steel transponder

Release mechanism - aluminium models

The release function is initiated at the HiPAP / HPR system. When activated, the transponder will float to the surface.

Note *Once the transponder reaches the surface, it can be lifted from the water by attaching a hook / rope to the transducer cage.*

The release mechanism has two moveable parts. These are:

- Hook
 - The hook sits at the bottom of the release unit, and holds the shackle to be released.

Figure 11 Release unit indicating the Hook

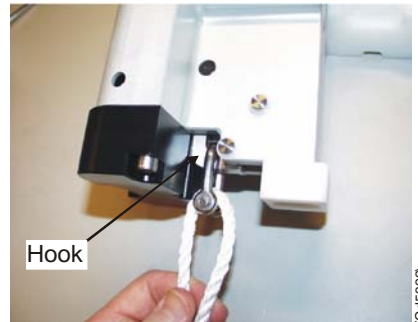

- L-arm
 - The L- arm is attached to the holding plate. (The holding plate has the shape of a very large coin, but much thicker).

Note *This holding plate has been adjusted during assembly and it MUST be loose. Do NOT attempt to tighten the bolt between the L-arm and the holding plate (see figure below).*

Figure 12 Release unit indicating the L-arm and holding plate

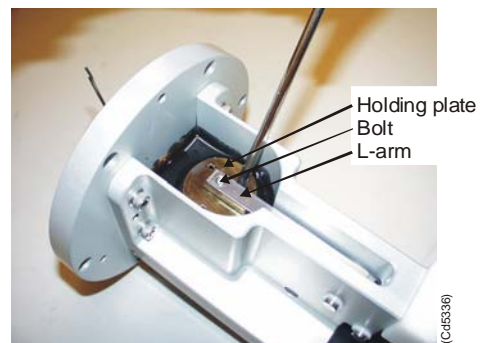

The release mechanism can be operate in one of the two following ways:

- Automatic
- Manual

Automatic release

Automatic release is normally used when the transponder is submerged.

- The release is performed within 10-15 seconds after the command is performed.

Note *Once the transponder reaches the surface, it can be lifted from the water by attaching a hook / rope to the transducer cage.*

Manual release

Manual release is normally used for testing purposes.

Note *Do NOT try to pull the L-arm or holding the plate away from magnet.*

Manual release procedure

- 1** Look into the small hole near the lower end of the springs.
 - The L-arm is just visible a few mm above the plastic "foot".
- 2** Insert a medium sized screwdriver between the L-arm and the plastic foot, and pry apart.
 - *Refer to figure 13.*
 - The mechanism will snap open.

Note *The L-arm is balanced between a strong magnet and two springs. When the mechanism is released, it kicks open with a sudden movement. Keep your fingers clear of the back of the L-arm and holding plate.*

*Figure 13 Release unit -
indicating manual release*

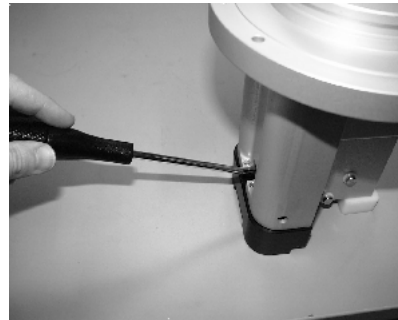

(C d532 1)

Setting the release mechanism

- 1** Ensure the anchor shackle (rope) is located in the jaws.
 - Do not use a chain. A chain can cause corrosion.
- 2** Snap the hook back onto position.
- 3** Fasten the required load onto the shackle.
- 4** Put the shackle onto the hook.
 - Ensure right side up. The curved end **onto the hook** and the shackle bolt **away from** the hook.
 - Refer to figure on page 35.
- 5** Swing the hook into place.
 - Ensure that the magnet face and the holding plate are free of grit and debris.
 - For proper function, ensure good parallel physical contact between the magnet and holding plate.
- 6** Push the back of the L-arm and holding plate towards the magnet until the magnet catches the holding plate.
- 7** Ensure the holding plate covers the circular face of the magnet.

Storage

Caution

A release unit must be stored in open position (released), as illustrated in the figure below.

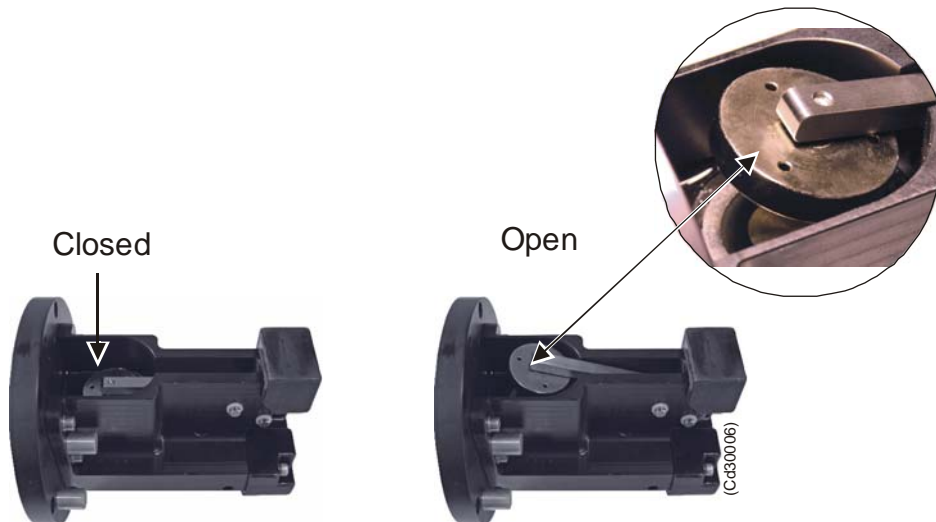

Figure 14 Release unit

→ *For information about manual release, refer to page 36.*

BATTERIES

This chapter provides information about the batteries used with the transponders described in this manual.

A battery is delivered as a separate unit.

The following battery types are available:

- Lithium (standard) (L)
- Alkaline (A)
- Rechargeable (N)

The transponders are normally self-contained with power. The standard battery is a lithium battery. It is used to ensure long life.

A battery consists of two sections, one for the receiver (Rx) and one for the transmitter (Tx).

Topics

- *Battery layout on page 40*
- *Battery specification on page 40*
- *Battery replacement on page 40*
- *Battery weight on page 21*
- *Lithium battery label on page 22*
- *Battery lifetime at operation on page 42*
- *Lithium battery packs on page 42*
- *Alkaline battery pack on page 45*
- *Rechargeable battery pack on page 47*
- *How to connect the transponder battery on page 49*
- *How to mount the transponder battery on page 50*
- *How to replace the transponder battery on page 51*

Related topics

- *Battery safety on page 138*

Battery layout

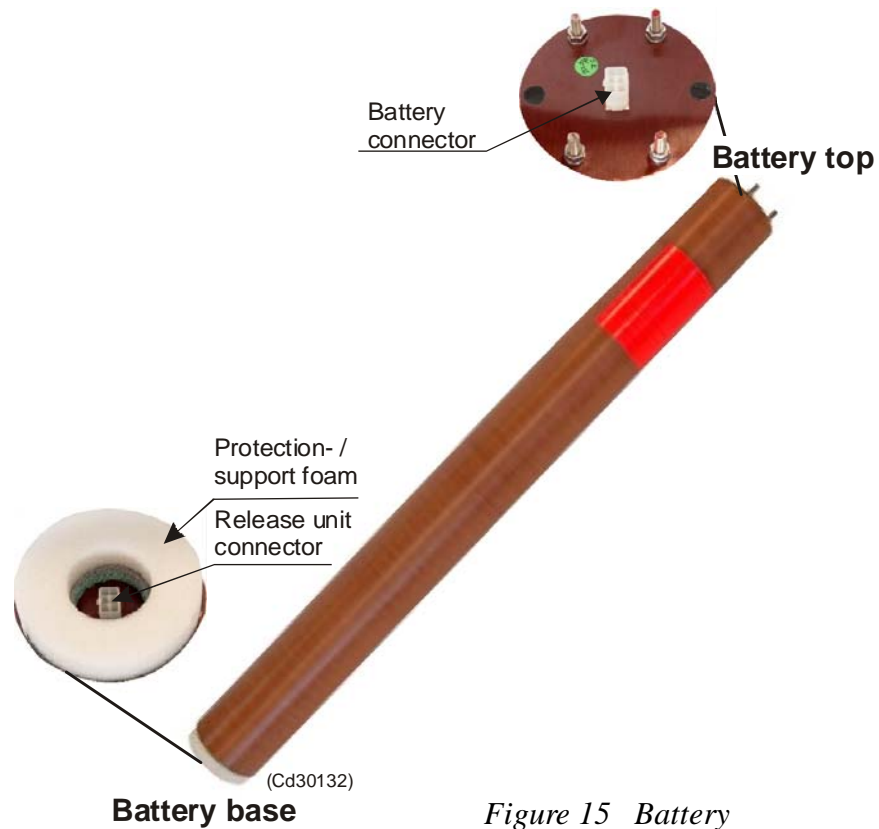

Figure 15 Battery

Battery specification

The battery specification includes:

- battery type
- Rx/Tx voltage
- number of battery cells used for Rx / Tx

Example: L10/36 (15/40)

The example given L10/36 (15/40), therefore indicates that this is a Lithium battery, with Rx voltage = 10 V / Tx voltage = 36 V. The Rx section comprises 15 battery cells, and the Tx section comprises 40 battery cells.

Battery replacement

The L10/36 (15/40) Lithium battery may be replaced by:

- the Alkaline battery A10/36 (24/24),
or
- the Rechargeable battery N10/36 (18/30).

An overview of the capacities of these batteries are presented in the table below. A more detailed specification is presented on the following pages.

Battery capacity

Battery data	Lithium	Alkaline	Rechargeable
Battery Type no.	L10/36 (15/40)	A10/36 (24/24)	N10/36 (18/30)
Maximum continuous on-time	180 days	71 days	16 days
Quiescent time	930 days	301 days	90 days
No. of replies, low source level	6.4 million	1.44 million	0.64 million
No. of replies, max source level	1.6 million	0.36 million	0.16 million

- The Alkaline battery capacity is approx. 20% of the Lithium battery.
- The rechargeable battery capacity is approx. 10% of the Lithium battery.

Battery lifetime at operation

The transponder has a battery monitoring function. For information on how to operate this function, see *the System operator manual/APOS on-line help*.

- Two pings are required to transmit the depth and compass information.
- Three pings to transmit the inclinometer information.
- When the transponder is set to HPR 400, and used for full telemetry, seven pings are required for each telegrams. The battery lifetime could therefore be much reduced from that stated in the figures below. However each reply is counted up and can be available to the operator.

The battery status presented in the APOS window is given at **High** source level.

Note

When the battery is disconnected, the battery status will be lost. When the battery is re-connected, the battery status reading will indicate 100% (as for a new battery). To keep track of the consumption, you are advised to make a note of the battery status before disconnecting.

The figures in this section indicating the respective battery lifetime, shows the lifetime based on 10 ms pulse length.

Lithium battery packs

To calculate the battery status, use the following equations:

- Max source level = $\frac{High}{2}$
- Low source level = $High \times 2$
- Min source level = $High \times 4$

Battery type	Transponder type
L 10/36 (15/40)	SPT 331 MPT 331
L 10/40 (3/11)	MPT 139/DTRspSx 110 Vac MPT 339/DTRspSx 110 Vac SPT 331/RspSx 110 Vac
L 10/40 (3/11) special cabling	SPT 133/RspSx 110 Vac SU
L 10/50 - (12/42)	MPT 139 series MPT 339 series

→ Battery specification, refer to page 40.

The figures show the lifetime based on 10 ms pulse length.

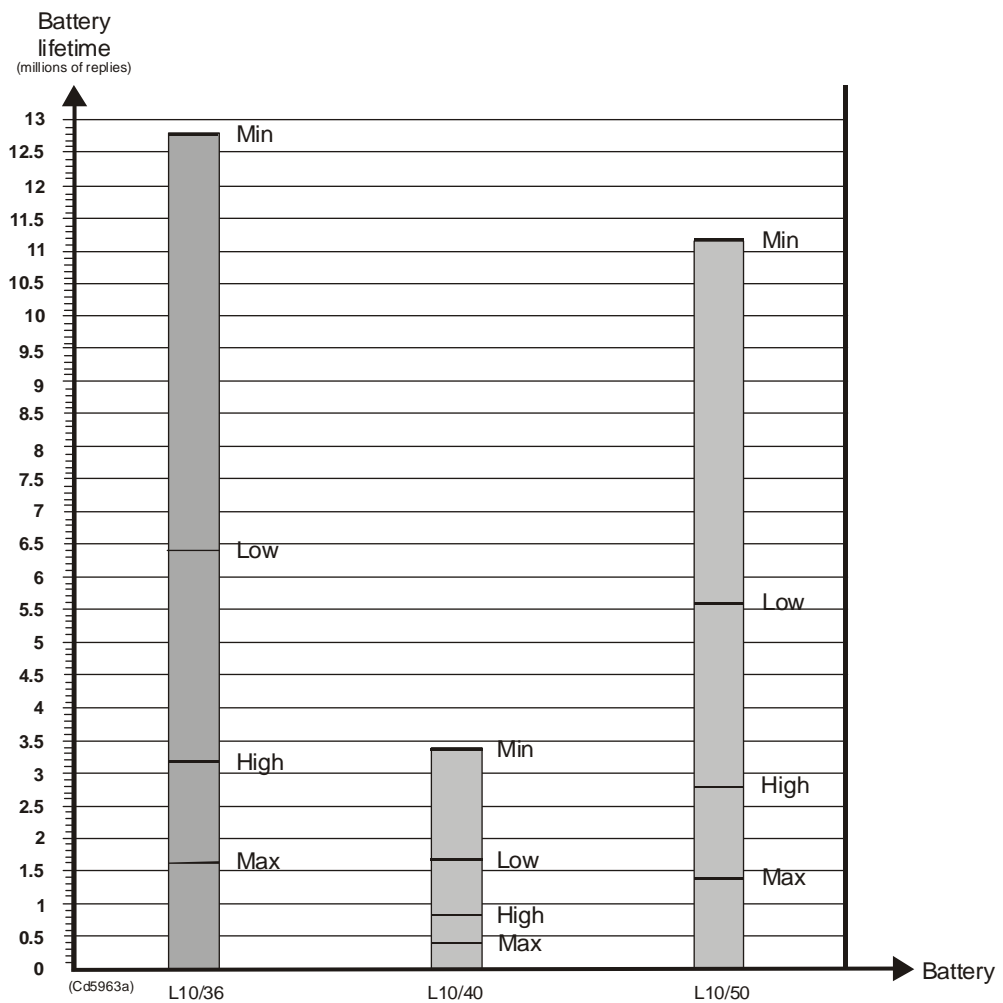

Figure 16 Battery lifetime at operation

Quiescent lifetime:

This is the total time the transponder can listen for interrogation pulses. After this time the transponder will not be able to reply.

Max continuous on time:

This is the maximum time the transponder can be continuously in operation, receiving and transmitting. If a low interrogation rate is used, this time may be consumed.



Figure 17 Battery lifetime at quiescent state

Lithium battery storage

→ Refer to “Storage” on page 143.

Self-discharge depends on the temperature. The higher the temperature the greater the self-discharge over time.

Shelf lifetime:

The batteries may be stored for up to 10 years with little loss of capacity. The losses are approximately according to the figures below (room temperature):

Capacity loss: 1st year - 3%

Next 9 years - 1.5% per year

Note *Total capacity loss over 10 years will therefore be approximately 15%.*

Alkaline battery pack

An alkaline battery, the Battery Pack A10/36 (24/24) is available. This battery pack may be used as a replacement for the transponder battery, L10/36 (15/40).

→ *Battery specification, refer to page 40.*

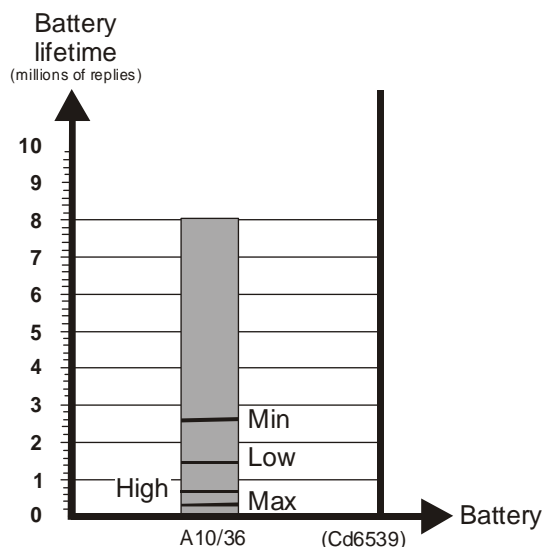

Figure 18 Battery lifetime at operation

Quiescent lifetime

This is the total time the transponder can listen for interrogation pulses. After this time the transponder will not be able to reply.

Max continuous on time

This is the maximum time the transponder can be continuously in operation, receiving and transmitting. If a low interrogation rate is used, this time may be consumed.

Battery lifetime at quiescent state

Max continuous on time:	71 days
Quiescent lifetime:	301 days

Alkaline battery storage

If the unit is not to be re-deployed in the near future, store it in a suitable environment.

Self-discharge depends on the temperature. The higher the temperature the greater the self-discharge over time.

Recommended storage temperature is room temperature or lower.

Shelf lifetime:

If the battery is stored in a dry place, (relative humidity < 65%), and with room temperature between 10 to 21 deg. C, up to 80% of initial capacity is still attainable after 4 years.

Caution

The batteries must be stored in an upright position.

Rechargeable battery pack

The SPT / MPT 331 transponders can be used with a rechargeable Nickel Cadmium (NiCd) battery, the Battery Pack N10/36 (18/30). This battery pack may be used as a replacement for the transponder battery, L10/36 (15/40).

→ *Battery specification, refer to page 40.*

The Battery Pack N10/36 (18/30) and battery charger is described in a separate manual.

→ *Refer to the BNC 1036 Instruction manual (doc. no. 164039).*

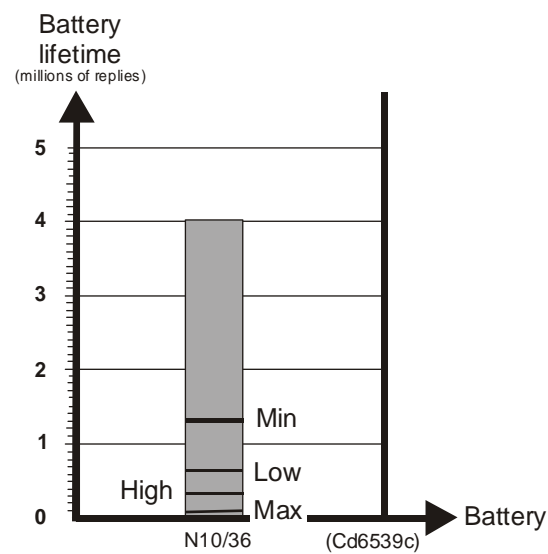

Figure 19 Battery lifetime at operation

Battery lifetime at quiescent state

Max continuous on time:	16 days
Quiescent lifetime:	90 days
Number of charge/discharge cycles:	250

How to connect the transponder battery

Important information

For the MPT / SPT 339 / 331 / 139 Rsp Sx transponders (w/power module), it is important to:

- When mounting the battery, connect the (black or yellow/green) wire (GND) to the power module (A), as illustrated in the figure below. This is GND connection for the external connector.
 - Refer to table for external connector pin layout, on page 23.
 - Refer to section on page 70.

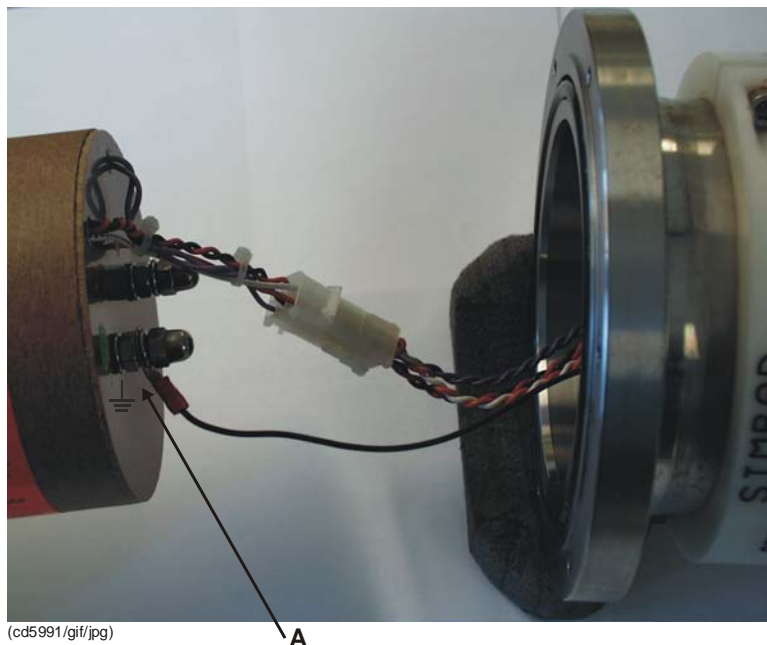

Figure 20 GND connection - external connector

Procedure

To connect the battery, the unit must be opened.

→ *Refer to page 63 for details.*

- 1 Grab the connector firmly using both hands. Press the connector onto the battery plug.

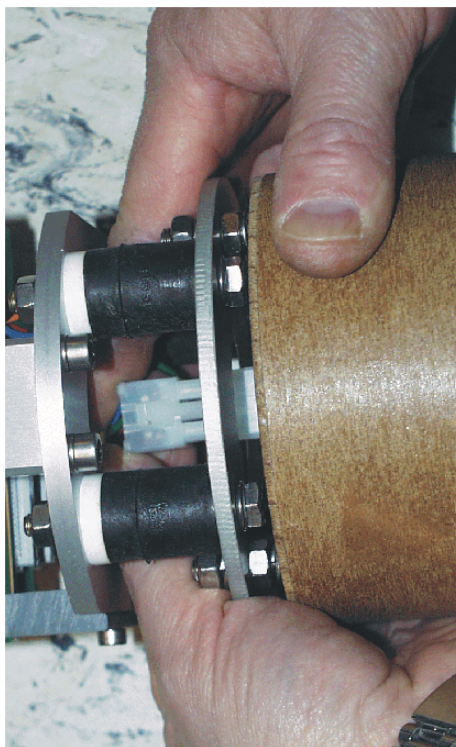

(Cd9937)

Figure 21 Connecting the battery

- 2 When the battery is connected, listen for the transponder initialization:
 - **Three bursts** should be transmitted **at a rate of one per second**.
 - If no **bursts** are heard, disconnect the battery immediately, and wait minimum 20 sec. before connecting / reconnecting it again.
- 3 When the battery is correctly connected, assemble the transponder.

→ *Refer to page 68 for details.*
- 4 Check that the unit is correctly assembled and sealed.
- 5 Perform a functional check before deployment.

How to mount the transponder battery

To mount the battery, proceed as follows:

→ See also how to connect the transponder battery on page 49.

- 1 Open the transponder unit.
→ Refer to page 63 for details.
- 2 Connect the battery as illustrated below.

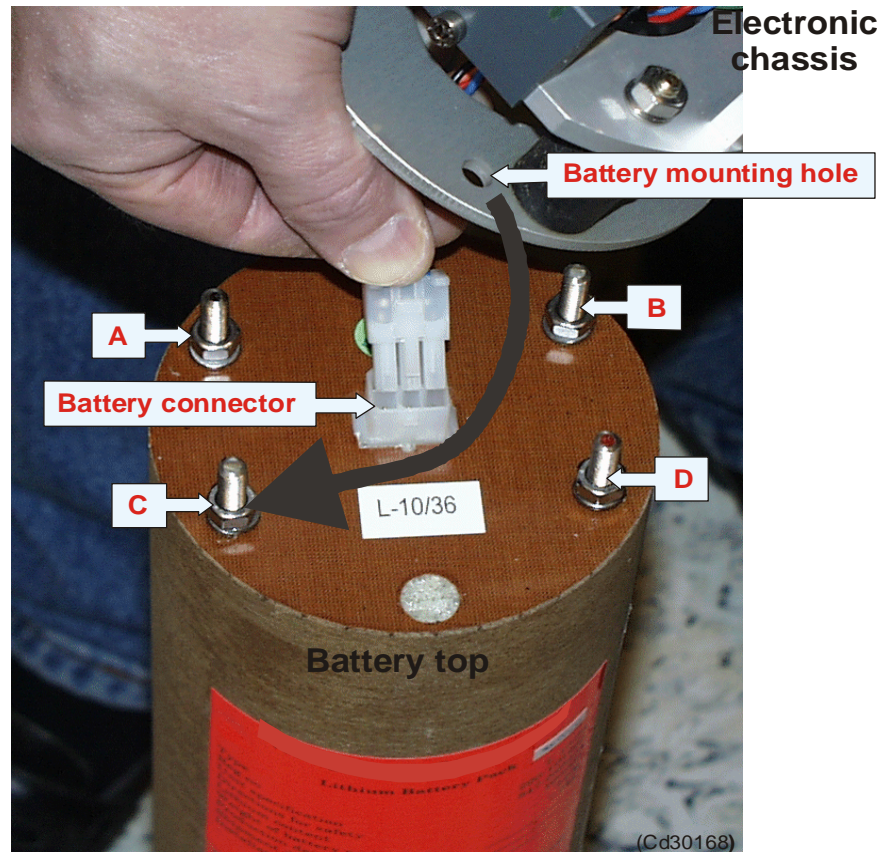

Figure 22 Connecting and mounting the battery

- 3 Fit the battery onto the chassis mounting holes (4 holes).
- 4 Mount the four nuts (A-D) and locking washers holding the battery to the chassis.
- 5 Assemble the transponder.
→ Refer to page 68 for details.

Note

Replace the used silica-gel bag with the new bag delivered with the battery.

- 6 Check that the unit is correctly assembled and sealed.
- 7 Perform a functional check before deployment.

How to replace a transponder battery

To replace a transponder battery, proceed as follows:

Procedure

- 1 Open the transponder unit.
→ Refer to page 63 for details.
- 2 If the transponder is fitted with a release unit, you must first disconnect and remove the release unit.
→ See page 67 for instructions.
- 3 Unplug the battery by :
 - Support the connector with your left hand and use a screw driver to press the release knob, as you pull out the connector.

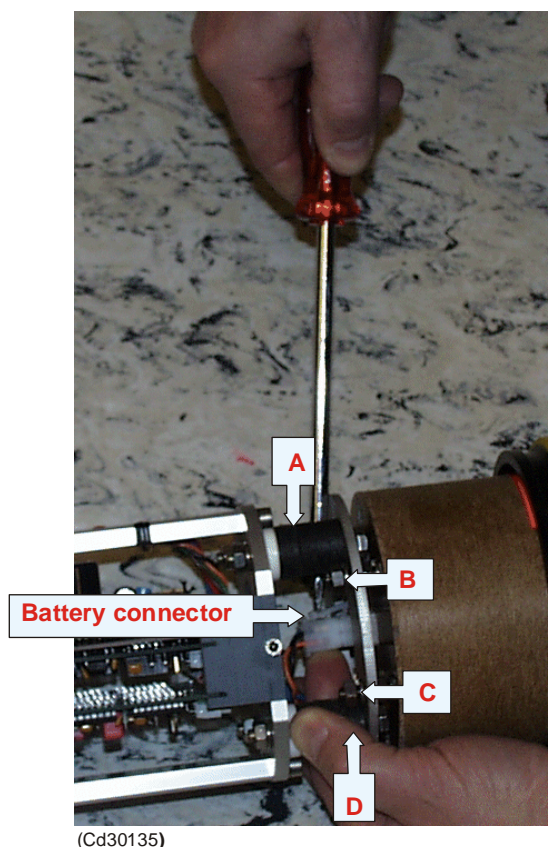

Figure 23 Battery connector and mounting screws

- 4 Remove the four nuts and locking washers (A-D) holding the battery to the chassis.
- 5 The battery can now be removed from the chassis.
- 6 Replace the battery pack in the reverse order, as follows:

- Mount the four nuts and locking washers holding the battery to the chassis.

→ *Refer to figure on page 51.*

For responder transponders:

7 Connect the battery.

→ *Refer to page 49 for details.*

8 Assemble the transponder.

→ *Refer to page 68.*

Note *Replace the used silica-gel bag with the new bag delivered with the battery.*

Note *When the battery is connected / disconnected the electronics is Reset.*

After Hard reset / Reset, Tx power is set to:

- HiPAP = HIGH
- HPR 400 = HIGH
- HPR 300 = MAXIMUM

→ *Refer to procedure on page 51.*

→ *Refer to procedure on page 51.*

TRANSPONDER CONFIGURATION

This section holds information about the configuration of a transponder. All transponders are configured by the manufacturer. The configuration may be altered if required. The procedure to perform alterations will depend on the HiPAP / HPR system in use.

A transponder can operate with the following topside systems:

- HiPAP
- HPR 400 series
- HPR 300 series
- Each transponder series is dedicated to a specific frequency band.
- Altering the configuration, switching between the operating systems or changing the channel settings is done by:
 - Acoustic telemetry.
(A HiPAP or a HPR 400 system is required).
 - Use of internal switches.
(Located on the microcontroller board).
- A large number of transponder channels are available (depending on the selected system) to prevent interference between transponders, if several are located in the same area (a channel being an interrogation and reply frequency combination).

Topics

- *Frequency bands on page 54*
- *Acoustic telemetry - basics on page 54*
- *Switch settings - basics on page 54*
- *HPR 400/HiPAP channels on page 55*
- *HPR 300 channels on page 58*
- *Responder and external power functions on page 61*
- *Double inclinometer on page 61*

Frequency bands

For the transponders described in this manual the frequency bands presented in table 5 are used.

Transponder	Frequency band number
SPT 331 series	B 1 - (30 kHz)
MPT 331 series	B 1 - (30 kHz)
MPT 339 series	B 1 - (30 kHz)
MPT 139 series	A 0 - (12 kHz)
SPT 133 unit	A 0 - (12 kHz)

Table 5 Frequency bands

Acoustic telemetry - basics

For information on how to use acoustic telemetry in the HiPAP / HPR 400 systems.

→ *Refer to the APOS on-line help.*

Switch settings - basics

The switches for frequency and channel set-up are located on the microcontroller board. The set-up must therefore be done before unit installation, while the unit is open. The following switches are available; a 4-bit DIL switch and two 16-position rotary switches.

→ *Ref paragraph on page 78.*

The set-up is described in the figure below and the switches are used as follows:

- The DIL switches (S1 - four switches) select the system of operation.
- The rotary switches S2 and S3:
 - For the HiPAP / HPR 400 systems - select the transponder operating frequency and channel.
 - For the HPR 300 series - set the interrogation frequency and command address.

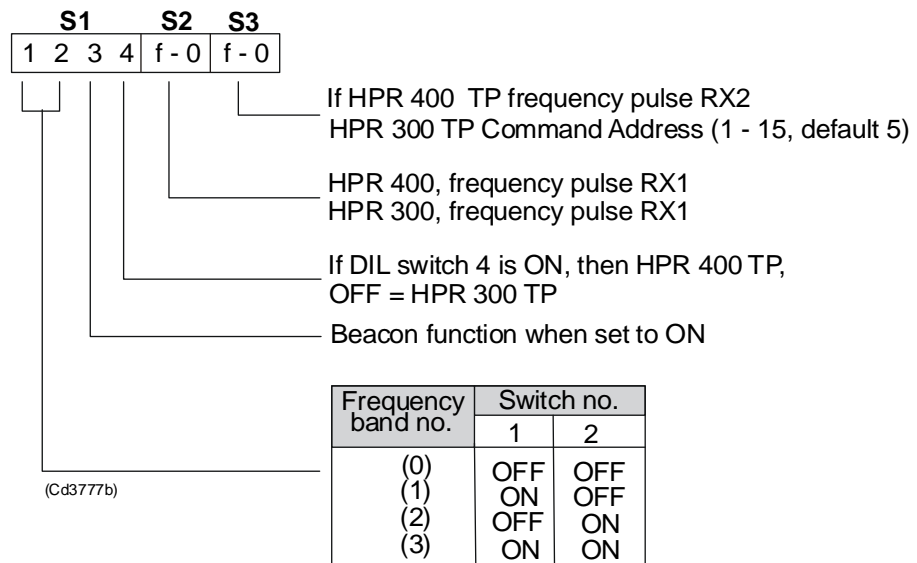

Figure 24 Microcontroller board - switch settings

HPR 400/HiPAP channels

HPR 400 system

The HPR 400 channel operation is the default. When set to HPR 400, the transponder executes all the commands for LBL and SSBL operation and subsea ranging. It also has an incorporated telemetry system.

HiPAP system

A HiPAP system uses the same channel working principle as a HPR 400 system. The following paragraphs therefore describe only the principles for a HPR 400 system.

Acoustic coding principle

The telemetry link uses a burst of seven pulses, all with different frequencies, transmitted in a sequence to make up a message. The coding principle is called “Factorial coding”, and has a total of 5040 combinations. 4096 of these are used for defining a 12-bit message, while the remaining; 4097 to 5040, are spare. The spare combinations may be used for other messages such as ASCII transmissions and special single messages.

A complete telegram is constructed by sending several messages in sequence.

HPR 400 channels and positioning frequencies

The number of channels available with an HPR 400 system depend on the transponder type used.

→ *An overview of available channels and operating frequencies, is given in the APOS on-line help.*

The HPR 400 system interrogates the transponders by transmitting two pulses with frequencies according to the protocol. The transponder reply is determined by the second interrogation pulse.

→ *Refer to figure on page 56.*

HPR 300

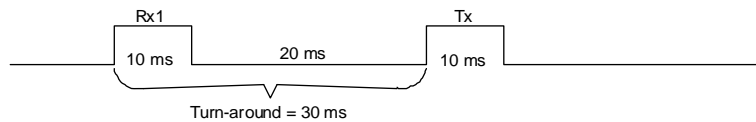

HPR 400

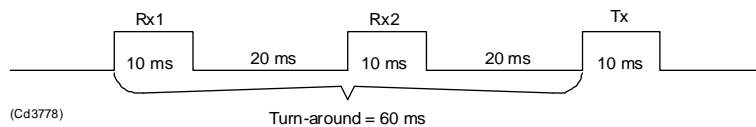

Figure 25 Transponder reception and transmission signal timing diagram

SPT and MPT 33x series

A total of 56 positioning frequency channels are available.

- Rx frequencies used are: 21.000 - 24.500 kHz.
- Telemetry frequencies used are: 25.000 - 26.500 kHz, at 250 Hz intervals.
- Tx frequencies used are: 27.000 - 31.500 kHz.

→ *An overview of available channels and operating frequencies, is given in the APOS on-line help.*

The switch settings for the SPT and MPT 33x series are:

DIP switches				
HPR	S1-1	S1-2	S1-3	S1-4
HPR 400	On	Off	Off	On
Rotary switches				
HPR 400	S2		S3	
	Set to the first digit of the desired channel number - Rx 1.		Set to the second digit of the desired channel number - Rx 2.	

Table 6 SPT and MPT 33x series - HPR 400 switch settings

MPT 139 series

A total of 30 positioning frequency channels are available.

- Rx frequencies used are: 10.000 - 12.500 kHz.
- Telemetry frequencies used are: 12.125 - 12.875 kHz, at 250 Hz intervals.
- Tx frequencies used are: 13.000 - 15.750 kHz.

→ *An overview of available channels and operating frequencies, is given in the APOS on-line help.*

Referring to figure 24, the switch settings for the MPT 139 series are:

DIP switches				
HPR	S1-1	S1-2	S1-3	S1-4
HPR 400	Off	Off	Off	On
Rotary switches				
HPR 400	S2		S3	
	Set to the first digit of the desired channel number - Rx 1.		Set to the second digit of the desired channel number - Rx 2.	

Table 7 MPT 139 series - HPR 400 switch settings

SPT 133 unit

The SPT 133 unit working principle with the HiPAP/HPR 400 system is the same as for the MPT 139 series.

HPR 300 channels

An HPR 300 system interrogates the transponders by transmitting one pulse with frequency according to the protocol.

→ *Refer to figure 25.*

The channels available are listed in table 8.

HPR 300 command function

The HPR 300 command function principles are the same for all the transponders described in this manual. In a HPR 300 system, the command system uses a combination of “Frequency shift keying” and “Pulse position coding”.

The commands are transmitted as a series of tone bursts, two frequencies being required to transmit the range of commands to each transponder. These are:

- An Individual Interrogation Frequency (IFF) - specific to the particular transponder.
- A Common Command Frequency (CCF) - common to all transponders. The CCF is 20.000 kHz.

The command information is contained in the delay between the IFF and the CCF signals, and in the CCF signal’s repetition period.

HPR 300 frequencies and switch settings

The number of channels available with an HPR 300 system depend on the transponder type used. This is specified in the following paragraphs.

→ *An overview of channels and operating frequencies, see also the APOS on-line help.*

SPT and MPT 33x series

For the SPT and MPT 33x series, the HPR 300 system uses the Common Command Frequency (CCF) of 20 kHz, and has a total of 14 channel numbers (frequency combinations) available.

Switch S2 setting	Transponder channel number	Operating frequencies (kHz)	
		Interrogation (TP Rx)	Reply (TP Tx)
1	B01	20.492	29.762
2	B02	21.552	30.488
3	B03	22.124	31.250
4	B04	22.727	31.847
5	B05	23.364	32.468
6	B06	24.038	27.173
7	B07	24.510	27.777
8	B08	25.000	28.409
9	B09	26.042	29.070
A	B11	21.552	27.173
B	B22	22.727	28.409
C	B33	23.923	29.762
D	B44	25.126	31.250
E	B55	26.455	32.468

Table 8 SPT and MPT 33x - HPR 300 frequencies and switch settings

→ Referring to figure 24, the HPR 300 switch settings are:

DIP switches				
HPR function	S1-1	S1-2	S1-3	S1-4
HPR 300	On	Off	Off	Off
HPR 300-Beacon function	On	Off	On	Off
Rotary switches				
HPR 300	S2		S3	
	Set to the interrogation frequency.		Set to the command address default setting - position 5.	

Table 9 SPT and MPT 33x series - HPR 300 switch settings

The system interrogates the transponders by transmitting one pulse with frequencies according to the protocol.

MPT 139 series

Note *The transponder can also be set to operate in HPR 300 when used by HPR 1507 or HPR 1530 systems.*

For the MPT 139 series, the HPR 300 system uses the Common Command Frequency (CCF) of 9506 Hz, and has a total of 5 channel numbers (frequency combinations) available.

Transponder channel number	Operating frequencies (kHz)	
	Interrogation (TP Rx)	Reply (TP Tx)
CCF	9.506	-
A01	9.901	13.158
A02	10.309	13.587
A03	10.707	14.045
A04	11.111	14.451
A05	11.547	14.881

Table 10 MPT 139 series - HPR 300 channel numbers and frequencies

For the MPT 139 transponders in HPR 300, the switch settings are:

DIP switches				
HPR function	S1-1	S1-2	S1-3	S1-4
HPR 300	Off	Off	Off	Off
HPR 300-Beacon function	Off	Off	On	Off
Rotary switches				
HPR 300	S2		S3	
	Set to the interrogation frequency.		Set to the command address default setting - position 5.	

Table 11 MPT 139 series - HPR 300 switch settings

SPT 133 unit

The SPT 133 unit working principle with the HPR 300 system, is the same as for the MPT 139 series.

Responder and external power functions

To initiate the responder and the external power function, the unit must be connected to a topside system via a cable. The pin allocations for of the unit's external connector:

→ *Refer to page 23.*

Double inclinometer

To initiate the double inclinometer transponder, the two units must be interconnected by the cable provided. The pin allocations for the unit's external connector:

→ *Refer to page 23.*

MAINTENANCE

No maintenance is normally required, apart from washing the unit. To change the battery pack or a circuit board, the unit must be dismantled.

Topics

- *Preventive maintenance on page 62*
- **Testing the transponder** on page 62
- *Dismantling the transponder on page 63*
- *Replacement of circuit boards on page 65*
- *Replacement of the transducer on page 66*
- *Remove the bottom end cap / release unit on page 67*
- *Transponder assembly on page 68*
- *Transducer handling on page 69*
- *Source level adjustment on page 69*
- *SPT/MPT 110 Vac transponder-power module on page 70*

Related topics

- *Safety information on page 138.*
- **Replacement of batteries** on page 51.

Preventive maintenance

Preventive maintenance is limited to keeping the unit clean.

Caution

Do not use high pressure water as this will damage the transducer face.

- Remove all traces of salt and debris.
- Before any connectors are disconnected, ensure the surrounding areas are dry.
- Inspect the unit for damage at regular intervals. Pay particular attention to the transducer surface. This is manufactured of a synthetic rubber material, and can be damaged easily.

Testing the transponder

A transponder may be tested for *short* periods on deck.

- *Refer to page 27 for information on how to test a transponder.*

Caution

Continuous operation in air may cause the unit to overheat.

Dismantling the transponder

The procedure for opening the pressure housing is identical for the all types of transponders described in this manual.

Pressure housing assembly:

The pressure housing comprises the cylinder body (housing), the transducer head and bottom end cap. The transducer head comprises of the transducer and the transducer cage. The transducer head has a screwed flange. The transducer head and the bottom end cap are both sealed into the housing, using two O-rings and a backup ring, and secured by six socket-head screws.

→ *An example of pressure housing assembly is shown in the figure on page 65.*

To remove the electronics chassis and battery pack from the housing, follow the procedure below:

Before you open the unit:

- 1 Wash the unit thoroughly in fresh water, and dry off any moisture on the outside.
- 2 Place the transponder horizontally on a flat, clean work-bench, and support it so it can not roll off.

Opening the unit:

- 1 Remove the six socket-head screws that secure the transducer head into the housing.
- 2 Screw the same screws into the threaded holes in the transducer head till they meet the housing flange.
- 3 Tighten the screws a little at a time to extract the transponder head out of the housing.

Note *If the transponder is fitted with a release unit or a responder trigger connector, care must be taken to ensure that the wires connected to the release unit and battery pack are not damaged when withdrawing the chassis.*

Note *DO NOT attempt to "unscrew" the transducer from the housing as the internal wiring and circuitry can be damaged.*

Note *DO NOT use a screw-driver or similar tool in an attempt to lever the transducer out. This will damage the sealing surfaces resulting in water penetration.*

- 4** Support the end cap as it is withdrawn. Once the O-ring is clear of the housing, the transducer and electronics chassis may be removed.
- 5** There is a wire from the release mechanism or the responder connector (whichever is fitted) to the base of the battery pack. Disconnect this wire from the battery pack before attempting to remove the chassis too far from the transponder housing.

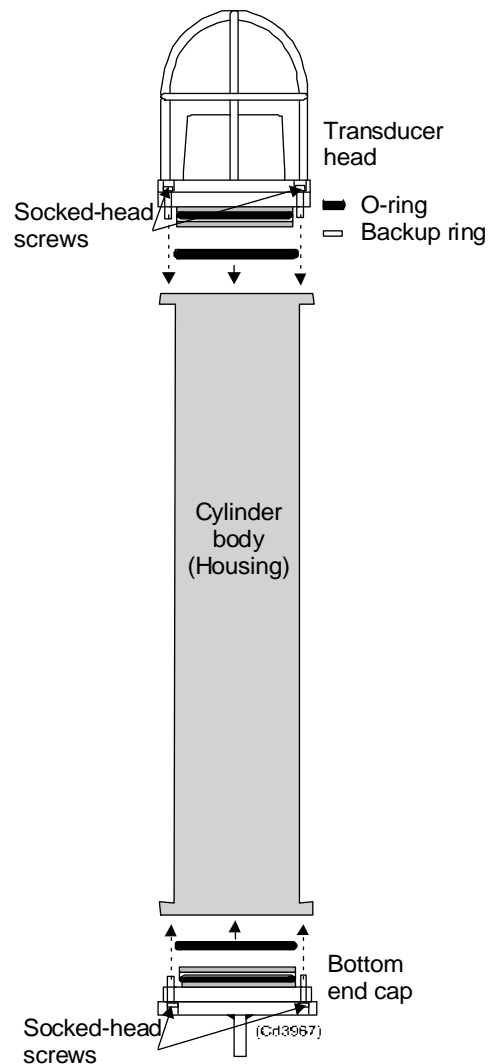

Figure 26 SPT 331 pressure housing assembly

Replacement of circuit boards

Rx board, Tx board and Microcontroller board

To replace one of these circuit boards, follow the procedure below:

- 1 Open the transponder.
→ Refer to paragraph on page 63.
- 2 Short together pins 3 and 6 in the plug connected to the electronics chassis, to discharge the transmitter capacitors.

- 3 Unscrew the plastic locking devices. The appropriate board can now be removed from the chassis.

Note

The Microcontroller board and Rx board are interconnected via a flat cable.

- 4 Mount the new circuit board and tighten the locking devices. Take care not to over-tighten the locks.
- 5 Assemble the transponder.
→ *Refer to paragraph on page 68.*

Rx-amplifier matching board and motherboard

To replace one of these circuit board, follow the procedure below:

- 1 Open the transponder.
→ *Refer to paragraph on page 63.*
- 2 Remove the soldering at the connections. Remember to mark the wires.
- 3 Unscrew the four screws holding the board. The appropriate board can now be removed from the chassis.
- 4 Assemble the transponder.
→ *Refer to paragraph on page 68.*

Replacement of the transducer

The transducer is sealed in the transducer cage. The transducer is a sealed unit and can not be opened. If the unit is not working, the whole unit must be replaced. To replace the transducer follow the procedure below:

SPT 133 unit, the MPT 339 and MPT 139 series

- 1 Open the transponder.
→ *Refer to paragraph on page 63.*
- 2 Remove the transducer cage. (The transducer cage is fitted with a screwed flange).
- 3 Remove the soldering at the connections Tp1 and Tp 2 on the Rx amplifier matching board (the Tp1 and Tp2 are clearly marked). Remember to mark the wires.
- 4 Assembly is basically the reverse of dismantling.

SPT 331 and MPT 331 series

- 1 Open the transponder.
→ Refer to paragraph on page 63.

Warning

Do not try to unscrew the two sealing screws on each side of the transducer flange (see figure on page 67).

- 2 Remove the complete transducer head.
 - For an inclination transponder, it is important to mount the 0-mark on the electronic chassis top-plate according to the 0-mark on the transponder head.
- 3 Assembly is basically the reverse of dismantling.

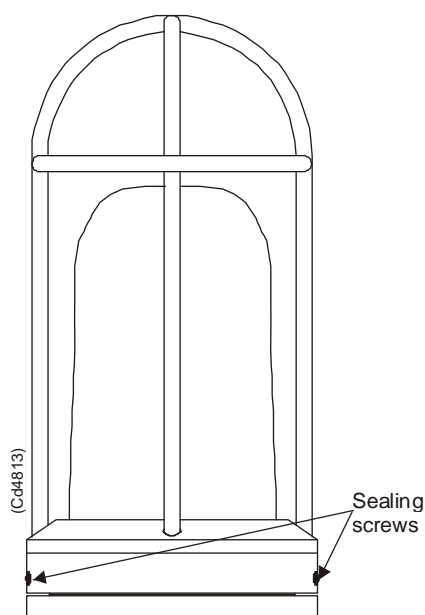

Figure 27 Transducer head, indicating the two sealing screws

Remove the bottom end cap / release unit

When fitted, the release mechanism forms the transponder bottom end cap. Removing a standard end cap or a release unit, is basically the same. The end cap is sealed into the transponder housing. A number of socket-head screws are positioned around the release unit flange. Six of these hold the release unit. The procedure describes how to remove the release unit:

- 1 Remove the six socket-head screws that secure the release unit into the housing. (The screws where the heads are flush with the surface of the mechanism flange).
- 2 Hold the transponder securely, and agitate the release unit back and forth in the tube to break the seal.
- 3 Pull the release unit out. The unit should seal tightly into the housing, so some force will be required to withdraw it. There are no threaded holes for assistance at the base end (ref paragraph on page 63), so care must be taken when using force.

Note *A 1,3 m length of cable is connected between the release unit and the battery pack. Ensure this cable is not damaged when withdrawing the unit.*

Note *DO NOT attempt to "unscrew" the unit from the housing as the internal wiring and circuitry can be damaged.*

Note *DO NOT use a screw-driver or similar tool in an attempt to lever the unit out. This will damage the sealing surfaces resulting in water ingress.*

- 4 The release mechanism may now be removed. Once the O-ring is clear of the housing, it will be loos.
- 5 Disconnect the release unit from base of the battery.
→ *Battery connectors, see page 40.*
- 6 Assembly is basically the reverse of dismantling.

Transponder assembly

To replace the electronics chassis and battery pack into the housing, follow the procedure below:

Before you start:

- 1 Inspect the O-rings and backup rings for damage. If in doubt, or if they have been used for more than one year, they should be replaced.
- 2 Place the new bag of silica-gel desiccant into the housing to absorb any humidity that may have entered the unit while it was open.

- 3 Ensure the mating surfaces and O-rings and backup rings are *completely* clean, then wipe a thin film of silica-gel over the rings and mating surfaces.

Assembling:

- 1 Carefully insert the chassis into the housing. Do not allow the circuit boards to knock against the housing, and ensure no wires are trapped between the chassis and the housing or left protruding from the housing.
- 2 Ensure the bag of silica-gel is positioned such that it will not prevent the chassis from fully entering the housing.
- 3 When the O-ring on the end cap meet the lead-in chamfer at the entrance to the housing, support the base of the transponder unit and push firmly on the transducer cage. Ensure the O-ring compress easily as the end cap enters the housing, and are not crimped or damaged.
- 4 When the end cap is fully home, align the screw holes and screw the six socket-head screws into the holes. Tighten the screws using a screwdriver-handled hexagonal key.
- 5 Wipe off any excess grease and clean the unit.
- 6 Perform a final check to ensure all the screws are correctly tightened and nothing has been left out.

The calibration is performed at the HiPAP / HPR system. Refer to *the System operator manual* for the calibration procedure / *APOS on-line help*.

Transducer handling

At transportation and storage, the transducer face and the O-ring groovers must be protected.

As a precaution at storage, short-circuit the electrical wires. This prevents unpleasant voltages, which otherwise may appear from temperature variations.

Source level adjustment

For certain applications, you may require to adjust the source level. This is done at the HiPAP / HPR system. For information on how to adjust the source level, refer to the *APOS on-line help*.

SPT/MPT 110 Vac transponder-power module

Drawings of the power modules wiring diagrams:

- SPT / MPT 110 Vac, see page 171.
- SPT 133/RspSx 110 Vac SU, see page 172.

As indicated on the drawings:

- The power unit is an AC / DC power unit.
- The 110 Vac input voltage is over-voltage protected.
- The trigger signal is overvoltage protected.
- The output voltage when using the 110 Vac power unit is:
 - * 48 Vdc directly to the transmitter, and
 - * the 48 Vdc is reduced to 10 Vdc in the LM317 controller.
- Tx power output is higher when using the power module (output 48 Vdc) than when using the the back up battery (output 40 Vdc).

SPT 133/RspSx 110 Vac SU specific:

The relay is activated by a command from the HPR / HiPAP system. The relay is active for 5 seconds.

MAIN PARTS

This chapter gives a short description of the transponder main parts.

- *An example of the transponder's main parts is shown in figure on page 72.*

Topics

- *Transducer on page 73*
- *Housing on page 73*
- *Bottom end cap / Release unit on page 73*
- *Circuit boards on page 74*

Related topics

- *Battery pack on page 39*

A transponder that requires external connection is equipped with:

- *An external connector on page 27*
- *A separate pigtail on page 27*

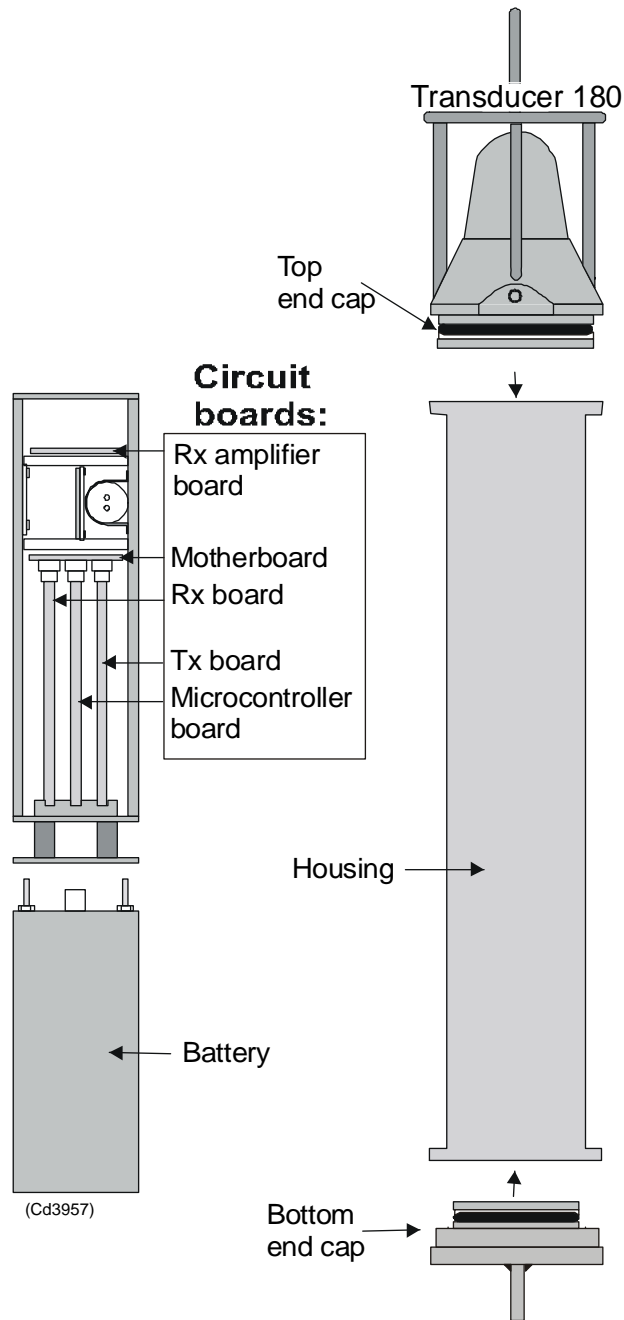

Figure 28 Example of transponder - main parts

Transducer

The transducer is mounted in one end of the cylindrical transponder. The following transducers are used:

- The transducer 30 has a 30° conical beam - MF only.
- The transducer 60 has a 60° conical beam - LF only.
- The transducer 180 has a 180° conical beam - MF and LF.

The transducer is connected to the electronics via two wires.

Depth and Temperature sensors

For transponders with Depth and Temperature sensors, the transponder head is equipped with a hole to enable direct contact between the sensors and the sea water.

Note

Ensure that this hole is kept clean and open at all times.

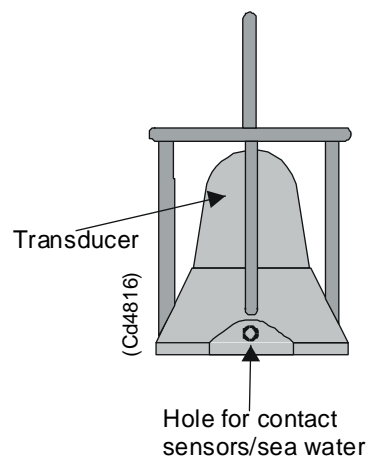

Figure 29 Transponder head for transponder with Depth and Temperature sensors

Housing

Information about the housing, refer to *Technical specification*.

Bottom end cap / Release unit

A standard bottom end cap includes a shackle. The following units are supplied with special end caps:

- Units including a Release mechanism (part of the Release mechanism).
- Units that require external connections:

→ *Ref paragraph on page 23.*

Circuit boards

The transponder electronics includes the five (5) circuit boards. These boards are standard for all applications.

Topics

- *Transmitter board (Tx) on page 75*
- *Receiver board (Rx) on page 76*
- *Rx amplifier board on page 77*
- *Microcontroller board on page 78*
- *Motherboard on page 79*

Transmitter board (Tx)

The Transmitter board is a general purpose transmitter, containing its own frequency generator, power control and power supply circuits, (the board feeds both the receiver and microcontroller circuit boards).

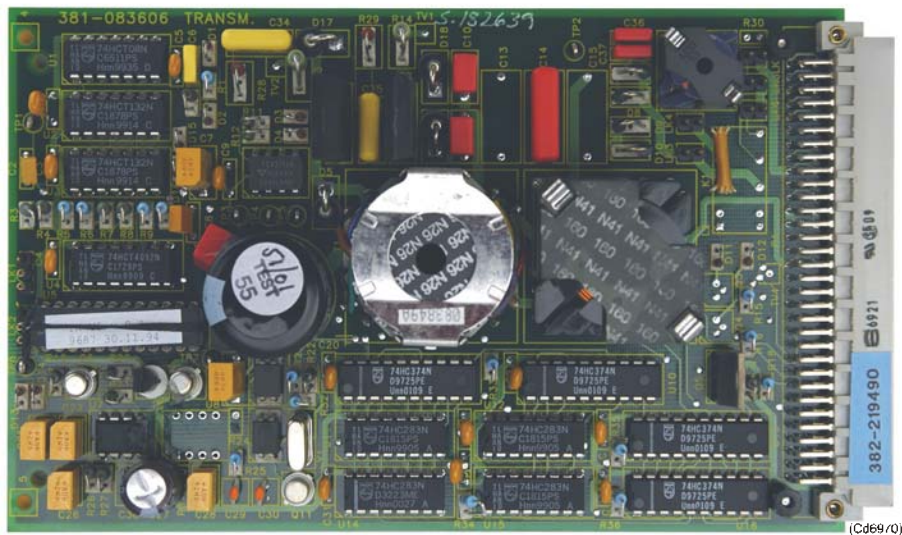

Figure 30 Transmitter circuit board

The board holds two voltage regulators which output the voltages required by the other boards. It also has a crystal oscillator which is used as the Tx frequency source, and a direct numerical synthesizer for generating the correct Tx frequency. Driver stages with power control, an output stage with over-current protection, and transducer matching circuits, complete the board.

Note *The Relay is only used with the following transponders:*
 - MPT 163series.

Note *The Relay is only used with the following transponders:*
 - Dual beam models.

Note *The Relay (K1) is only used with the following transponders:*
 - MPT 313 series.

Receiver board (Rx)

The receiver board is designed to receive transponder interrogation signals and telemetry signals. It contains nine narrow-band channel receivers, and a WIDE-detector and phase-locked loops for generating the right modulation frequencies to the channel receivers.

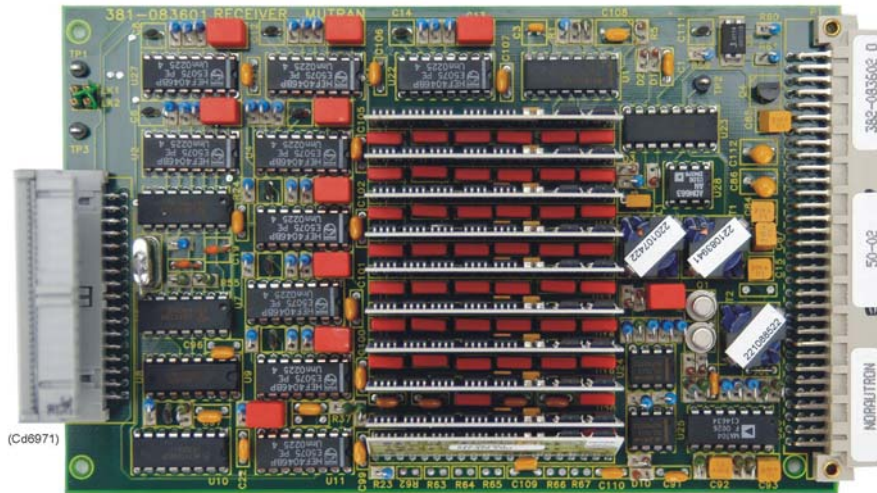

Figure 31 Receiver circuit board

The board consists of a two stage amplifier with signal limitation and an anti-aliasing filter, two channel receiver stages for wake-up, and seven channel receiver stages for telemetry, all constructed as ceramic hybrid circuits. The channel receivers perform mixing, low-pass filtering, summing and envelope detection. The outputs from the channel receivers are fed to the microcontroller.

Rx amplifier matching board

The TP-PREAMP 24K Hz acts as a matching preamplifier between the transducer and the Channel Receiver circuit board.

→ Refer to figure 32 for the block diagram.

The transducer is connected to TP1 and TP2.

The incoming signal passes through the matching component, T1. From T1, the input signal is connected to a two-step amplifier.

The first step of this amplifier is a low noise FET with a voltage gain of approximately 10 dB.

The signal then enters the micropower operational amplifier, where the gain can be altered in two steps; either 0 dB or 6 dB (approximate values). A logic “0” at TP7 causes 0dB to be achieved. A logic “1” at TP7 causes 6 dB to be achieved.

The amplifier contains a bandpass filter to reduce the input noise before the signal is connected to the output transformer T2. The output to the Rx board is on TP8 and TP9.

TP5 and TP6 are connected to the Transmitter board. When the system is transmitting, a TR-switch in the T1 block protects the input of the amplifier. Transmitted signals are transformed via T1 and leave the board from terminals TP1 and TP2.

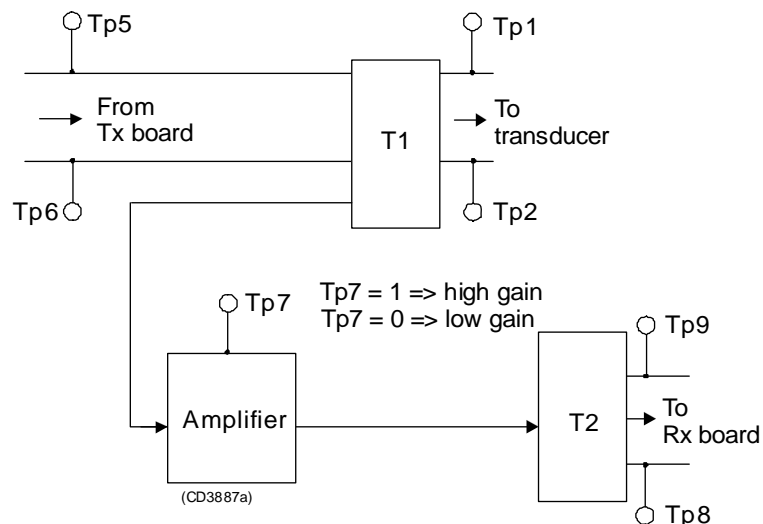

Figure 32 Rx amplifier matching board - block diagram

Microcontroller board

The Microcontroller board is a general purpose single microcontroller board, with the main task of performing calculations and digital signal control. It uses the *87C196KC/KD Microcontroller* manufactured by Intel, and is also equipped with a number of timers, inputs and outputs.

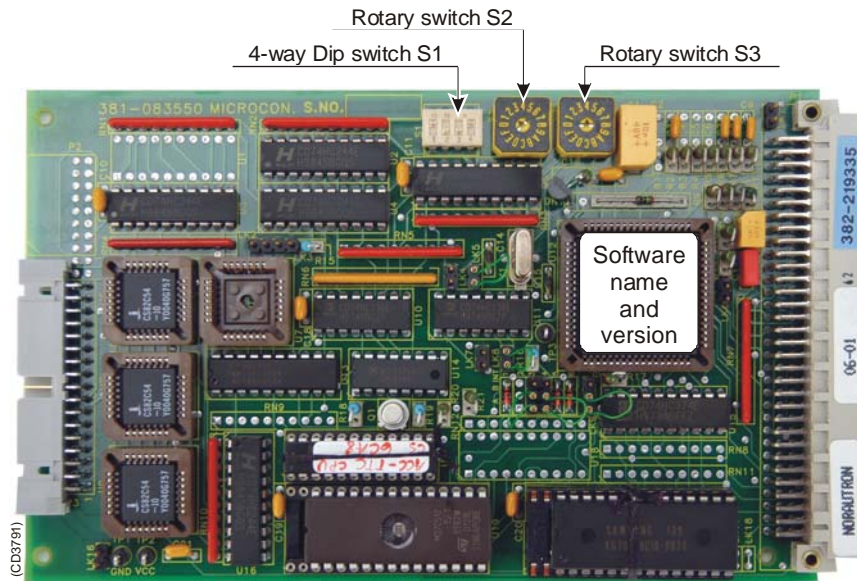

Figure 33 Microcontroller circuit board - switch locations

The 87C196 microcontroller is the main component on the board. It can be run in different modes such as active, idle and power down, the inactive modes being used to save power. The microcontroller performs all the calculations and controls all the board's inputs and outputs. The timers on the board are used for dividing down the off-board Phase-Locked-Loop frequencies, controlling the receiver frequency channels.

Switches

The board carries one 4-way Dip-switch block and two 10-position rotary switches:

- The Dip-switch block is used to set the system's operating frequency band.

Motherboard

The motherboard contains all the input/output interfacing for the transponder. It has an interface connection (P4) for the two inclinometers and a + 10 V supply which is turned on only during processing to conserve battery life. It also carries an interface plug (P5) for the Depth/Temp serial line. The TTL interface is buffered through U1 on the motherboard.

Interconnections

The interconnections will differ from tp model to tp model.

Note

For details of the interconnections between the circuit boards, the transducer and the electronics, and the battery and the electronics, contact Kongsberg Maritime.

AUXILIARY EQUIPMENT

This chapter describes various types of auxiliary equipment that may be used to secure a transponder.

Topics

- *Anchor-weight on page 80*
- *Floating rope on page 80*
- *Auxiliary equipment supplied by Kongsberg Maritime on page 80*

Anchor-weight

A transponder requires an anchor-weight of approximately 60 to 70 kg to hold the transponder securely in position on the seabed. Use a length of **rope** 3 to 15 metres long to attached the anchor, and then attach the "top" of the rope to the transponder.

Caution

Do not use a chain. A chain can cause corrosion.

The length of the rope depends on the transponder use.

- If you use LBL with very long base line in deep water, use up to 15 m.
- If you use SSBL on a flat seabed, a 3 m rope is sufficient.

Floating rope

A floating rope may be used when collecting the transponder by an ROV.

- *Refer to example in the figure on page 84.*

Auxiliary equipment supplied by Kongsberg Maritime

Kongsberg Maritime may supply:

Topics

- *Floating collar on page 81*
- *Mounting brackets on page 81*
- *Guiding collars on page 83*

Floating collar

The collar is divided lengthwise into two halves. These halves are placed around the transponder housing and bolted together, enabling the collar to be assembled onto a transponder without removing the end cap clamping ring.

→ *Floating collars on page 173*

Mounting brackets

Different types of mounting brackets are available. This section presents a few examples:

- Mounting funnel
- Transponder rack (may be supplied by Kongsberg Maritime).

Mounting funnel

The figure below gives an example of how to mount a transponder using a mounting funnel. The funnel may have a closed or open bottom, depending on requirements. The mounting funnel material is chosen based on the customer's input regarding installation construction and transponder placement.

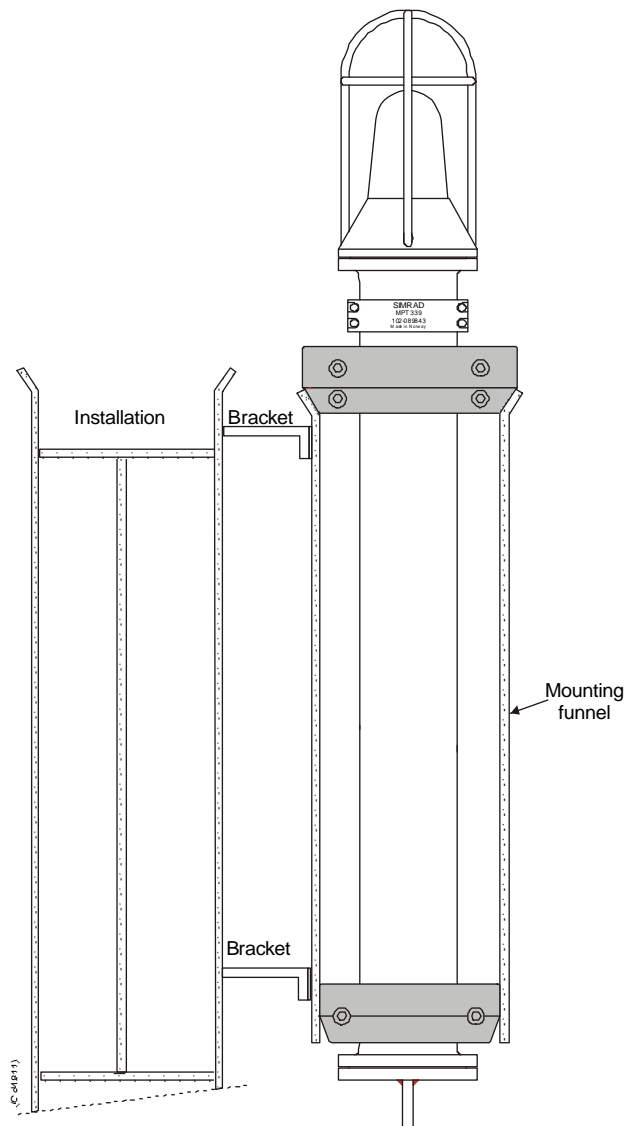

Figure 34 Example of mounting funnel

Transponder rack

The transponder rack illustrated in the figure below, may be used to mount an inclinometer transponder on a Kill and choke line. This type rack can not be used with an ROV.

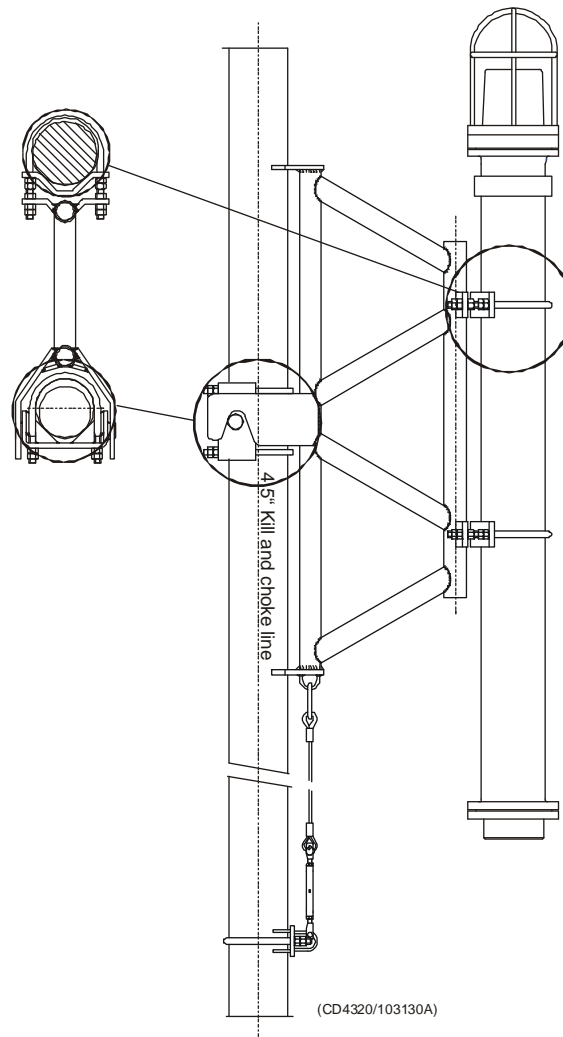

Figure 35 Transponder rack

Guiding collar

Different types of guiding collars may be used. The most common guiding collar delivered by Kongsberg Maritime comprises of two separate units; an upper and a lower. Each unit is divided into two parts. These parts are placed around the transponder housing and bolted together. It is important that the collar units are mounted correctly.

→ This is illustrated in the figure on page 84.

Note

Other types of guiding collars may be supplied on request.

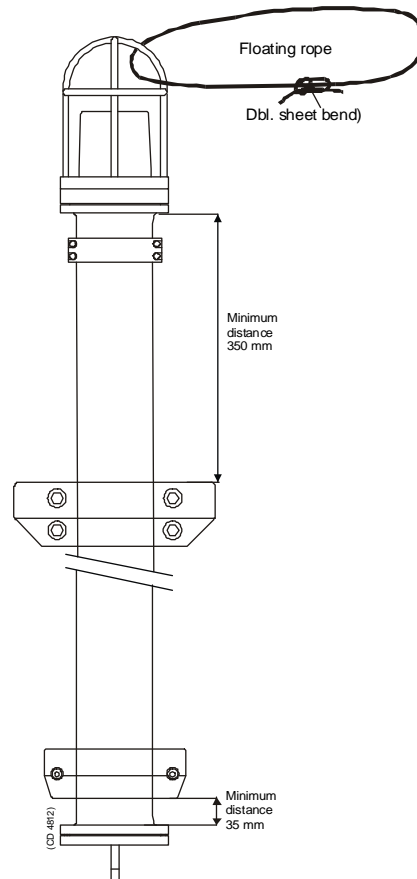

Figure 36 Example of transponder with fitted guiding collar and floating rope

A groove (12 mm wide) is made on the upper guiding collar unit.

Example of use:

The purpose of this groove is to fit the transponder correctly when using a funnel for mounting the transponder. The groove slides over a corresponding guide fin within the funnel. Correct mounting will restrict rotation of the transponder within the funnel. The funnel is equipped with a locking pin to secure the transponder (not supplied by Kongsberg Maritime).

SPARE PARTS

Introduction

This chapter lists the parts and modules defined by Kongsberg Maritime as *Line Replaceable Units (LRUs)* for the SPT and MPT x3x transponder series. These LRUs are the individual parts and items which the manufacturers considered are replaceable by the local maintenance engineer. Exploded figures are included to assist you with part identification.

Codes used

The following codes are used in the parts lists:

Part no. - Kongsberg Maritime's part number.

Item name - The name of the item.

Technical data - Technical specifications and any other relevant information.

Drw. ref. - Reference number of the production or illustration drawing where the item is included. If a number is given here, the drawing will be included in the manual's/document's drawing file.

Drw. pos. - The item's position number on the drawing referenced above.

No. in sys. - The quantity of the item used in the system. *Note that this information is not provided for standard components such as nuts, bolts and washers.*

Rec. spares - The quantity of the item recommended to be carried as spares onboard the vessel. *Note that this information is not provided for standard components such as nuts, bolts and washers.*

Topics

- *Accessories on page 87*
- *Batteries on page 88*
- *Sensors on page 88*

- *SPT 331/St on page 89*
- *SPT 331/R -St on page 91*
- *SPT 331/I-St on page 95*
- *SPT 331/II-St on page 97*
- *SPT 331/RspSx 110 Vac-St on page 102*
- *SPT 133 RspSx 110 Vac SU-St on page 110*

- *SPT 331 on page 104*
- *SPT 331/R on page 106*
- ***SPT 331/RspSx 110 Vac transponder on page 108***

- *MPT 339/St on page 114*
- *MPT 339/DTR-St on page 116*
- *MPT 339/DTRspSx 110 Vac-St on page 118*
- *MPT 339/DT on page 123*
- *MPT 339/DTR on page 120*

- *MPT 331/DTDuB-St on page 124*
- *MPT 331/DTRDuB-St on page 126*
- *MPT 331/DTDuB on page 127*
- *MPT 331/DTRDuB on page 129*

- *MPT 139/St on page 130*
- *MPT 139/DT-St on page 132*
- *MPT 139/DTR-St on page 134*
- *MPT 139/DTRspSx 110 Vac-St on page 136*

Accessories

This list includes the common accessories used for all transponder types. Since the figure position differs on the figures for these common items, the Drw. pos. is left out.

Note

O-/Backup rings are listed in the accessories list, and referred to as A/B/C/D in the figures for some transponders.

Part no.	Item name	Drw. ref.	No. in sys.
-	Technical data	Drw. pos.	Rec.spares
540-084173	O-ring	Figures	2
-	124,3 x 5,7	A	2
540-021249	O-ring	Figures	2
-	101,0 x 5,34	C	2
549-086691	Backup ring	Figures	2
-	101,0 x 5,34	D	2
560-085925	Socket-heads screws	Figures	6
-	-	-	6
599-089487	Plug for ID-clamp	Figures	3
-	-	-	-
Depends on model	Information clamp ring	Figures	1
	w/freq.	-	-
Depends on model	Information clamp ring	Figures	1
	w/reg. no.	-	-
380-101422	Flat cable	N/A	-
-	internal	-	-
599-089318	PCB guide	Figures	1/1
599-089320	-	-	-
654-085883	Aquva lube	N/A	-
-	-	-	-
654-077261	Silicone grease	-	1
-	-	N/A	1
659-063787	Bag of desiccant 10 g	-	1
-	Silica-gel	30	1
659-033481	Loctite	Figures	-
-	Type 242/243	-	1
119-086645	Floating collar	N/A	-
-	3000 m	-	-
599-089549	Guiding collar upper	N/A	-
599-089550	Guiding collar lower	-	-

Part no.	Item name	Drw. ref.	No. in sys.
-	Technical data	Drw. pos.	Rec.spares
857-160780	SPT and MPT x3x series Instruction manual	N/A	1
-	(This manual)	-	-

Sensors

Part no.	Item name	Drw. ref.	No. in sys.
-	Technical data	Drw. pos.	Rec.spares
298-098127	DT sensor	N/A	-
-	-	N/A	-
339-211580	Inclinometer- sensor	N/A	-
-	-	N/A	-

Batteries

The battery is delivered as a separate unit.

Note

The Lithium battery is specified for each transponder.

Part no.	Item name	Drw. ref.	No. in sys.
-	Technical data	Drw. pos.	Rec.spares
290-216804	Alkaline battery	N/A	-
-	A10/36 (24/24)	N/A	-
	Unit label: 216956		
290-212364	Rechargeable battery	N/A	-
-	N10/36 (18/30)	N/A	-
	Unit label: 212795		

SPT 331/St transponder

The standard SPT 331 basic transponder is delivered with aluminium housing, see page 104.

Complete transponder without battery

Part no.	Item name	Drw. ref.	No. in sys.
-	Technical data	Drw. pos.	Rec.spares
102-103061	SPT 331/St Transponder complete without battery	Figure page 90	1
-	All main modules are included (except for battery)	N/A	-

Standard battery

Part no.	Item name	Drw. ref.	No. in sys.
-	Technical data	Drw. pos.	Rec.spares
290-103053	Battery pack (lithium)	Figure page 90	1
-	L10/36 (15/40)	9	-

Other available batteries

→ Refer to the table on page 88.

Main modules

Main modules for the SPT 331/St stainless steel transponder.

Part no.	Item name	Drw. ref.	No. in sys.
-	Technical data	Drw. pos.	Rec.spares
312-089983	SPT 331/St Transducer	Figure page 90	1
-	-	1	-
299-102851	Electronic chassis	Figure page 90	1
-	Motherboard, Rxamp board and sensors (if used) are included	27	-
382-102852	Tx board	Figure page 90	1
-	-	2	-
382-083551	Microcontroller board	Figure page 90	1
-	-	3	-
382-102853	Rx board	Figure page 90	1
-	-	4	-
599-112057	Housing w/flanges	Figure page 90	1
-	-	14	-
599-089836	Bottom end cap	Figure page 90	1
-	-	26	-

Accessories

→ Refer to the table on page 87.

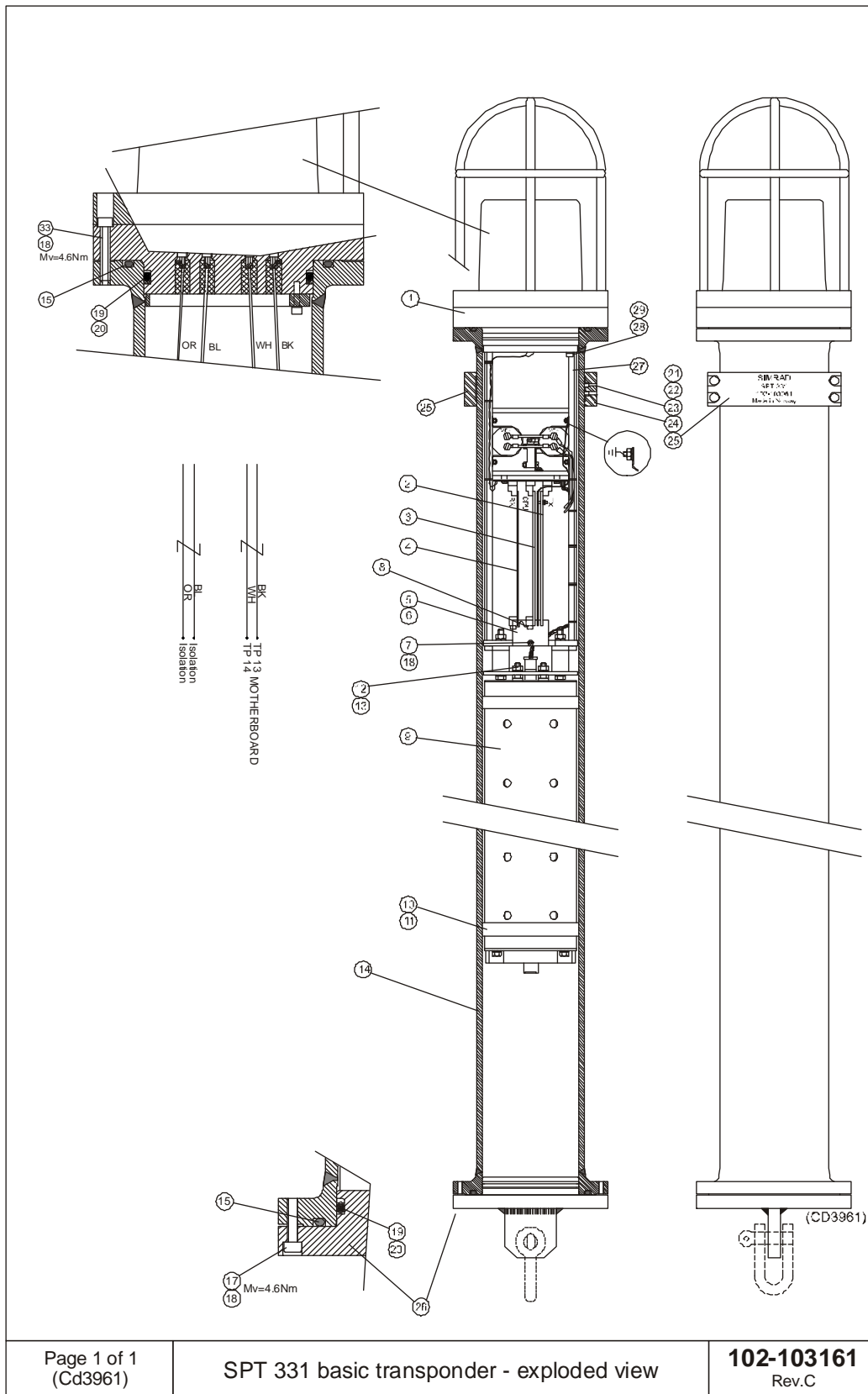

SPT 331/R-St transponder

The standard SPT 331/R transponder is delivered with aluminium housing, see page 106.

Complete transponder without battery

Part no.	Item name	Drw. ref.	No. in sys.
-	Technical data	Drw. pos.	Rec.spares
102-103253	SPT 331/R-St Transponder complete without battery	Figure page 92	1
-	All main modules are included (except for battery)	N/A	-

Standard battery

Part no.	Item name	Drw. ref.	No. in sys.
-	Technical data	Drw. pos.	Rec.spares
290-103053	Battery pack (lithium)	Figure page 92	1
-	L10/36 (15/40)	9	-

Other available batteries

→ Refer to the table on page 88.

Main modules

Main modules for the SPT 331/R-St stainless steel transponder.

Part no.	Item name	Drw. ref.	No. in sys.
-	Technical data	Drw. pos.	Rec.spares
312-089983	SPT 331/R-St Transducer	Figure page 92	1
-	-	1	-
299-102851	Electronic chassis	Figure page 92	1
-	Motherboard, Rxamp board and sensors (if used) are included	27	-
382-102852	Tx board	Figure page 92	1
-	-	2	-
382-102853	Rx board	Figure page 92	1
-	-	4	-
382-083551	Microcontroller board	Figure page 92	1
-	-	3	-
599-112057	Housing w/flanges	Figure page 92	1
-	-	14	-
499-089594	Release mechanism	Figure page 92	1
-	(Separate list ref. page 93)	26	-

Accessories

→ Refer to the table on page 87.

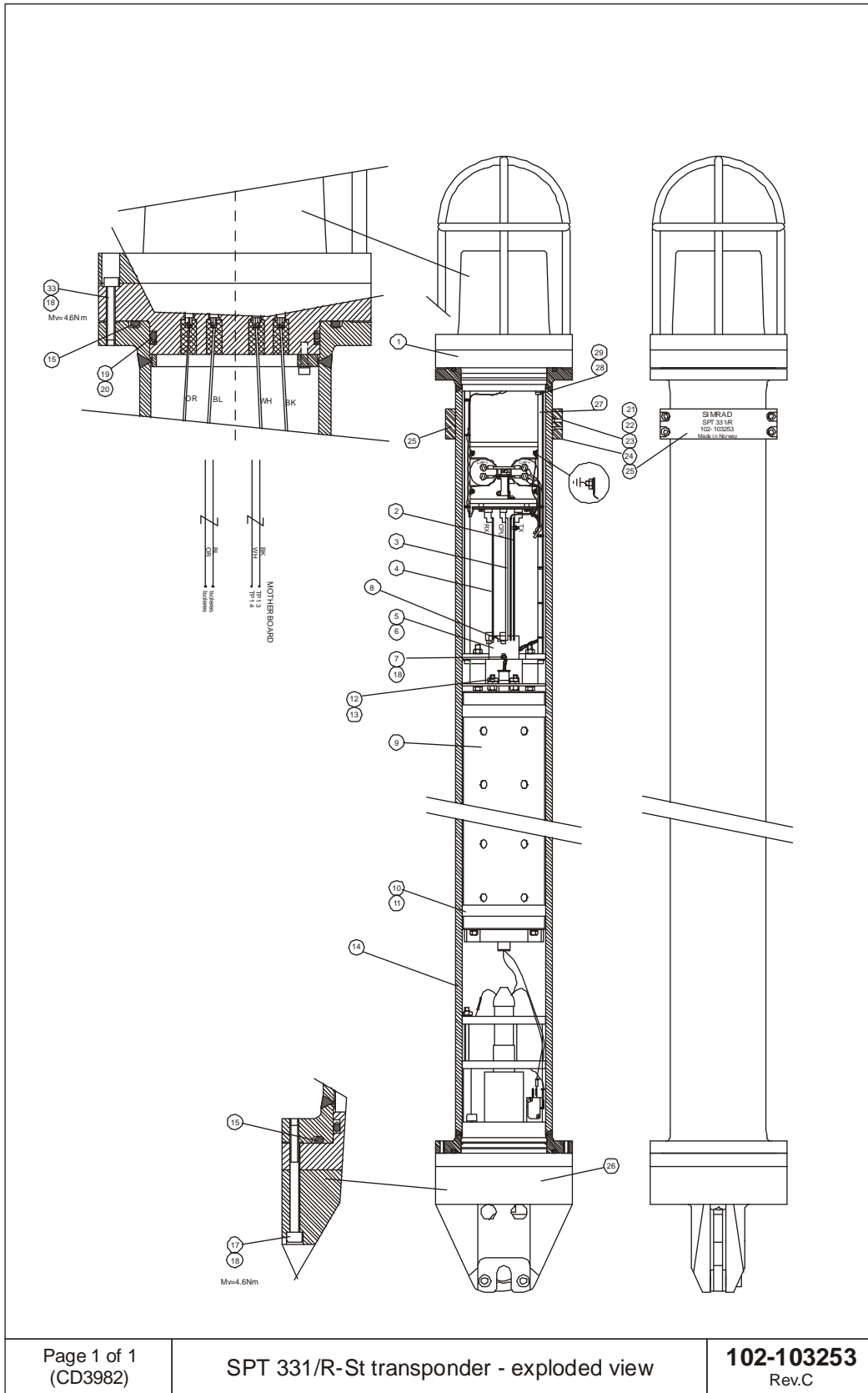

Release mechanism unit

Complete unit

Part no.	Item name	Drw. ref.	No. in sys.
-	Technical data	Drw. pos.	Rec.spares
499-089594	Release unit complete	Figure page 101	1
-	All main modules are included	N/A	-

Main modules

Main modules for the release mechanism unit.

Part no.	Item name	Drw. ref.	No. in sys.
-	Technical data	Drw. pos.	Rec.spares
581-088052	Pressure springs	Figure page 101	1
581-088208	-	8/9	-
599-089575	Bottom end cap	Figure page 101	1
-	-	10	-
540-075817	O-ring	Figure page 101	2
-	23,40 x 3,53	13	2
540-076169	O-ring	Figure page 101	2
-	34,2 x 3,0	15	2
330-085761	DC-motor	Figure page 101	1
-	-	31	-
290-085607	Battery	Figure page 101	6
-	(6 separate cells) Lithium 3,5 V - LSH20CNR	46	-
370-084488	Plug house	Figure page 101	1
-	-	47	1
599-088157	Cable socket	Figure page 101	2
-	-	48	-
599-088157	End cap	Figure page 101	1
-	-	49	-

Accessories

→ Refer to the table on page 87.

SPT 331/I-St transponder

Complete transponder without battery

Part no.	Item name	Drw. ref.	No. in sys.
-	Technical data	Drw. pos.	Rec.spares
102-103062	SPT 331/I-St Transponder complete without battery	Figure page 96	1
-	All main modules are included (except for battery)	N/A	-

Standard battery

Part no.	Item name	Drw. ref.	No. in sys.
-	Technical data	Drw. pos.	Rec.spares
290-103053	Battery pack (lithium)	Figure page 96	1
-	L10/36 (15/40)	9	-

Other available batteries

→ Refer to the table on page 88.

Main modules

Main modules for the SPT 331/I-St stainless steel transponder.

Part no.	Item name	Drw. ref.	No. in sys.
-	Technical data	Drw. pos.	Rec.spares
312-089983	SPT 331/I-St Transducer	Figure page 96	1
-	-	1	-
299-103147	Electronic chassis	Figure page 96	1
-	Motherboard, Rxamp board and sensors (if used) are included (1)	27	-
382-102852	Tx board	Figure page 96	1
-	-	2	-
382-083551	Microcontroller board	Figure page 96	1
-	-	3	-
382-102853	Rx board	Figure page 96	1
-	-	4	-
599-112057	Housing w/flanges	Figure page 96	1
-	-	14	-
599-089836	Bottom end cap	Figure page 96	1
-	-	26	-

1 Inclinometer - separate unit see page 88.

Accessories

→ Refer to the table on page 87.

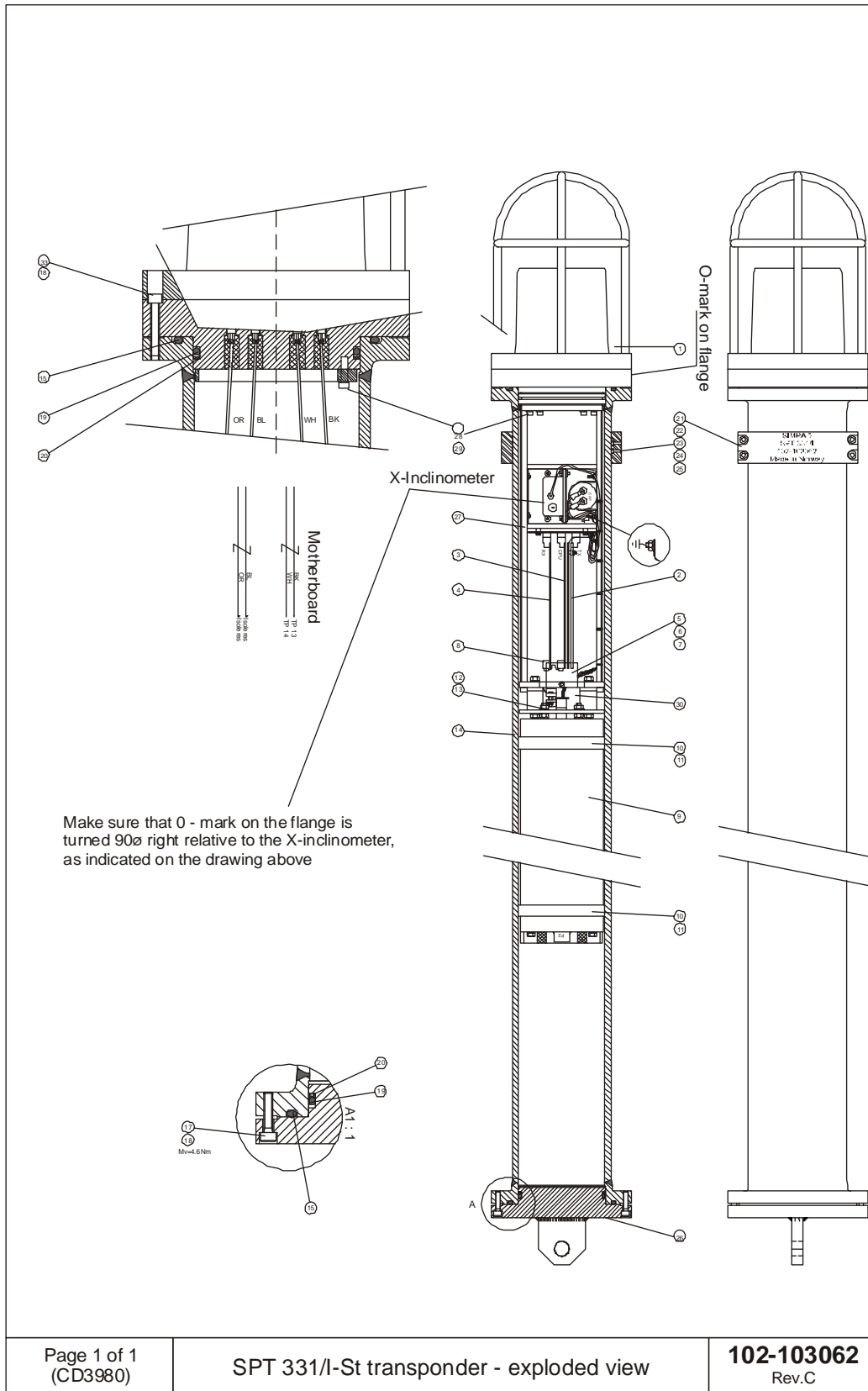

SPT 331/II-St transponder

This section includes parts for the SPT 331/II stainless steel transponder and the SPT 331/II separate inclinometer unit.

Complete transponder

Part no.	Item name	Drw. ref.	No. in sys.
-	Technical data	Drw. pos.	Rec.spares
102-103013	SPT 331/II-St Transponder complete	Figure page 98	1
-	All main modules are included	N/A	-

Main modules

Main modules for the main unit of the SPT 331/II-St stainless steel transponder.

Part no.	Item name	Drw. ref.	No. in sys.
-	Technical data	Drw. pos.	Rec.spares
312-089983	SPT 331/II-St Transducer	Figure page 98	1
-	-	1	-
299-103090	Electronic chassis	Figure page 98	1
-	Motherboard, Rxamp board and sensors (if used) are included (1)	27	-
382-102852	Tx board	Figure page 98	1
-	-	2	-
382-102853	Rx board	Figure page 98	1
-	-	4	-
382-083551	Microcontroller board	Figure page 98	1
-	-	3	-
290-103179	Battery	Figure page 98	1
-	Battery pack L10/36 (15/40) is included	9	-
599-112057	Housing w/flanges	Figure page 98	1
-	-	14	-
599-103073	Bottom end cap	Figure page 98	1
-	-	26	-
380-087206	Cable	-	1
-	-	-	-
370-087202	UW receptacle	Figure page 98	1
-	10.00.3.07.00.1.10 7 pins	34	-
379-087203	Sealing cap	Figure page 98	1
-	10.20.3.07.00 LV088	35	-
599-103089	Protection ring for plug	Figure page 98	1
-	10.20.3.07.00 LV062	37	-

1 Inclinometer - separate unit see page 88.

Accessories

→ Refer to the table on page 87.

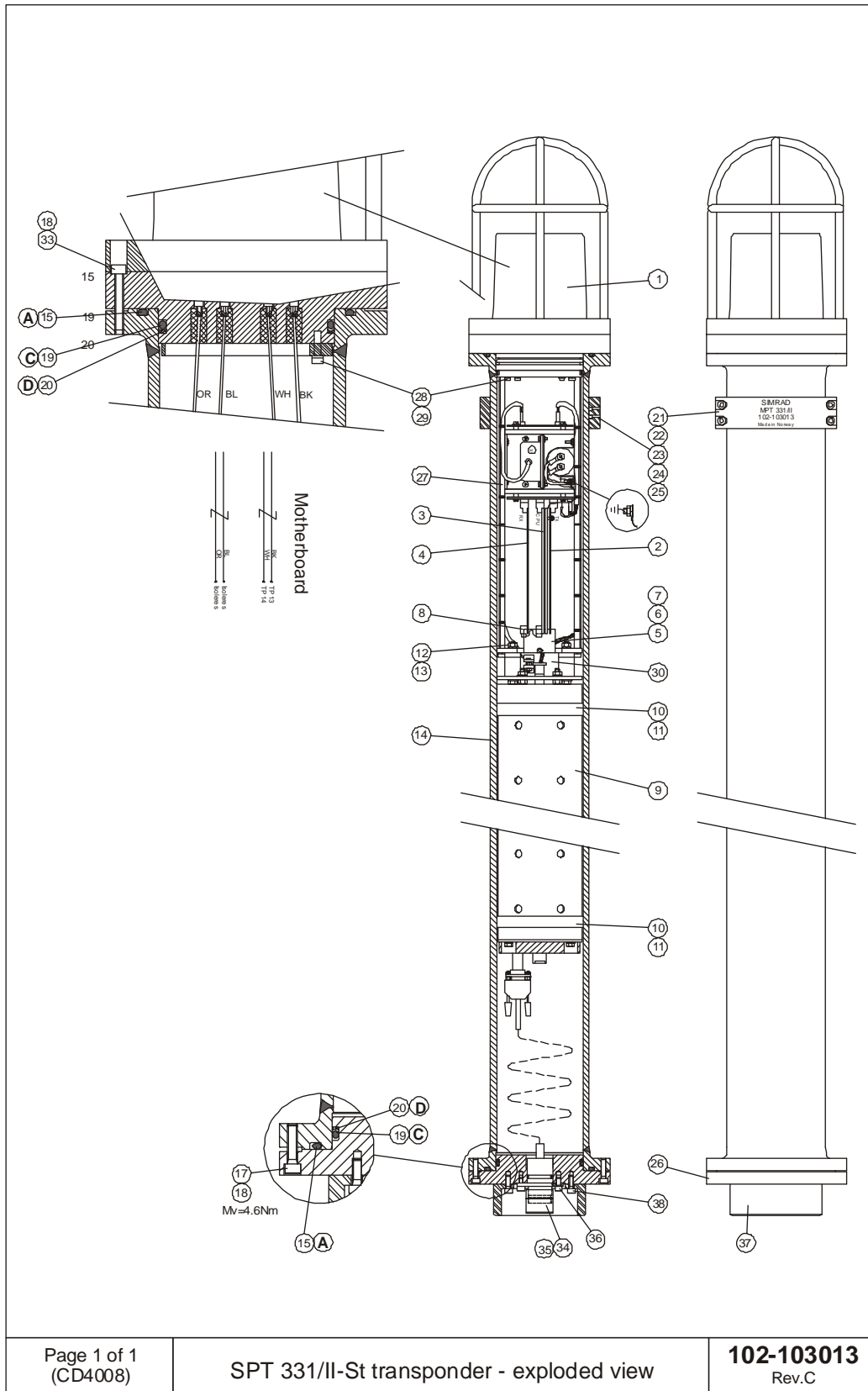

SPT 331/II-St separate inclinometer unit**Complete unit**

Part no.	Item name	Drw. ref.	No. in sys.
-	Technical data	Drw. pos.	Rec.spares
499-103014	Inclinometer unit	Figure page 100	1
-	All main modules are included	N/A	-

Main modules

Main modules for the SPT 331/II-St separate inclinometer unit.

Part no.	Item name	Drw. ref.	No. in sys.
-	Technical data	Drw. pos.	Rec.spares
370-087202	UW receptacle	Figure page 100	1
-	10.00.3.07.1.10 7 pins	3	-
339-211580	Inclinometer	Figure page 100	2
-	-	5	-
599-103074	Cage	Figure page 100	2
-	-	6	-

Accessories

→ Refer to the table on page 87.

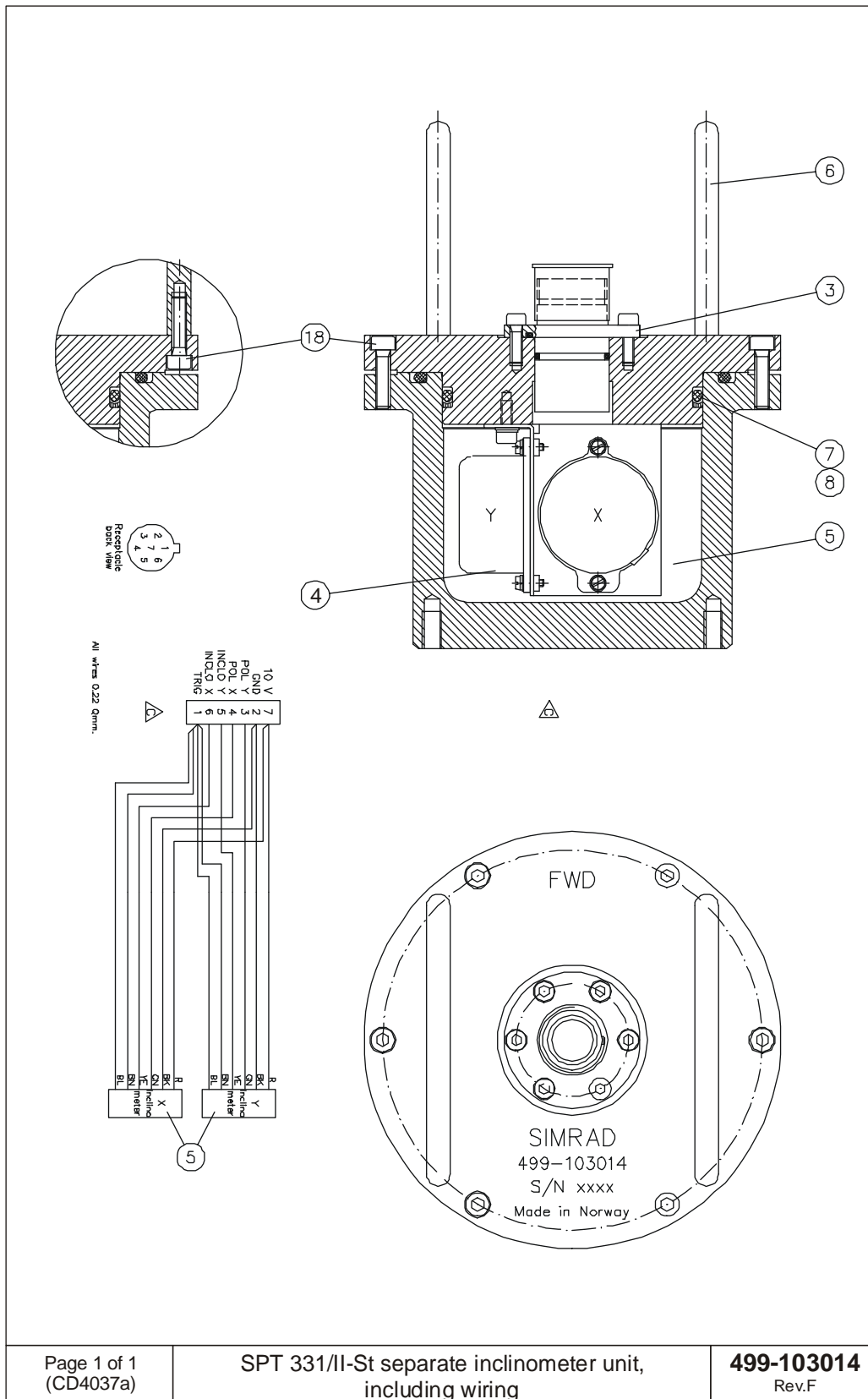

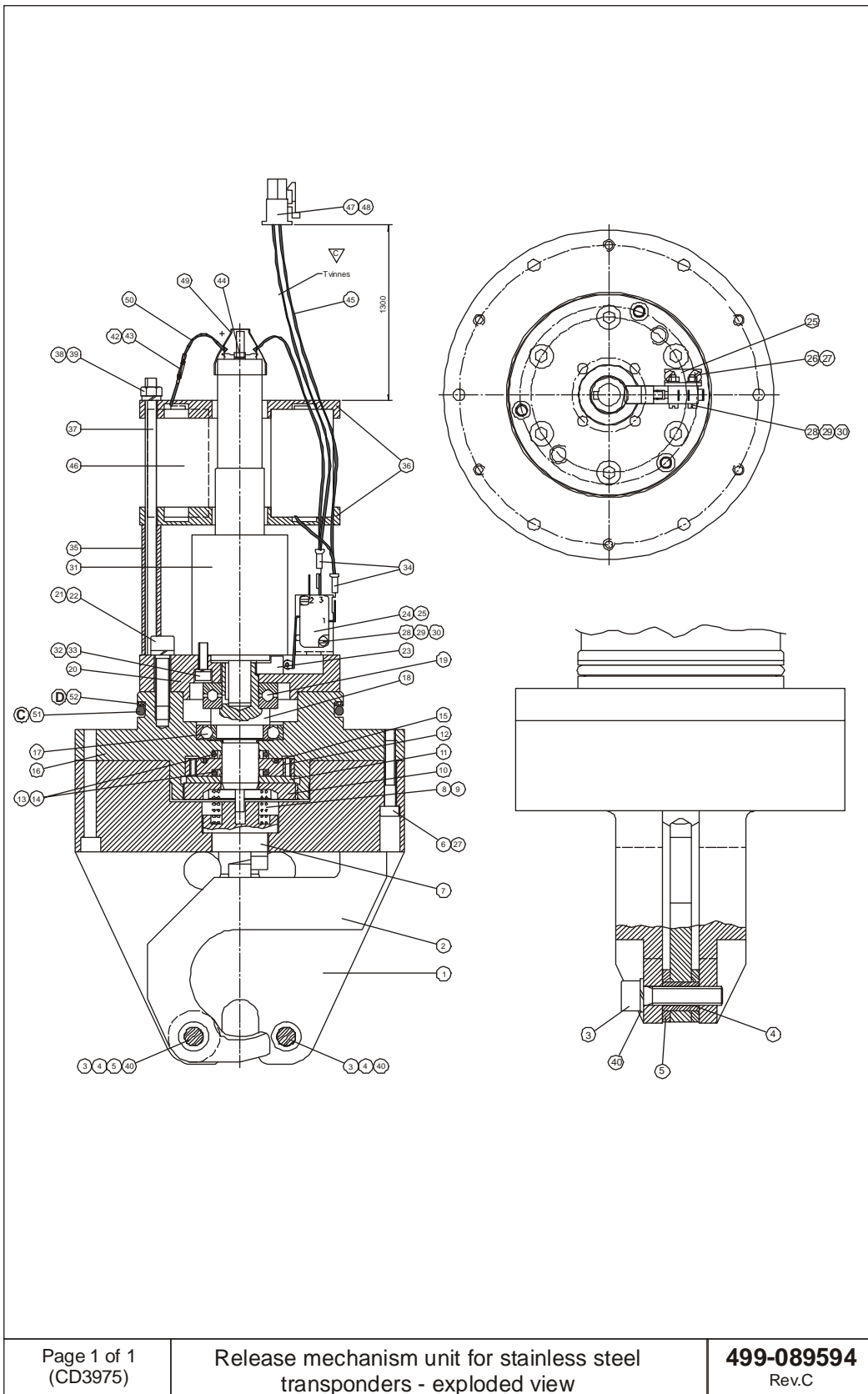

SPT 331/RspSx 110 Vac-St transponder

The standard SPT 331/RspSx 110 Vac transponder is delivered with aluminium housing, see page 108.

Complete transponder without battery

Part no.	Item name	Drw. ref.	No. in sys.
-	Technical data	Drw. pos.	Rec.spares
102-210972	SPT 331/RspSx 110 Vac-St Transponder completee without backup battery	Figure page 103	1
-	All main modules are included (except for backup battery)	N/A	-

Battery

Part no.	Item name	Drw. ref.	No. in sys.
-	Technical data	Drw. pos.	Rec.spares
290-102726	Battery pack (lithium)	Figure page 103	1
-	L1040 (3/11)	9	-

Main modules

Main modules for the SPT 331/RspSx 110 Vac-St transponder.

Part no.	Item name	Drw. ref.	No. in sys.
-	Technical data	Drw. pos.	Rec.spares
312-089983	SPT 331/RspSx 110 Vac-St Transducer	Figure page 103	1
-	-	1	-
299-211002	Electronic chassis (short)	Figure page 103	1
-	Motherboard, Rxamp board and sensors (if used) are included	45	-
382-102852	Tx board	Figure page 103	1
-	-	2	-
382-102853	Rx board	Figure page 103	1
-	-	4	-
382-083551	Microcontroller board	Figure page 103	1
-	-	3	-
107-103000	Power module	Figure page 103	1
-	-	9	-
599-112212	Housing	Figure page 103	1
-	(short)	14	-
370-086656	UW receptacle	Figure page 103	1
-	10.00.2.07.1.10 7 pins	37	-
379-087453	Protection cap	Figure page 103	1
-	10.20.2.00.01	39	-

Accessories

→ Refer to the table on page 87.

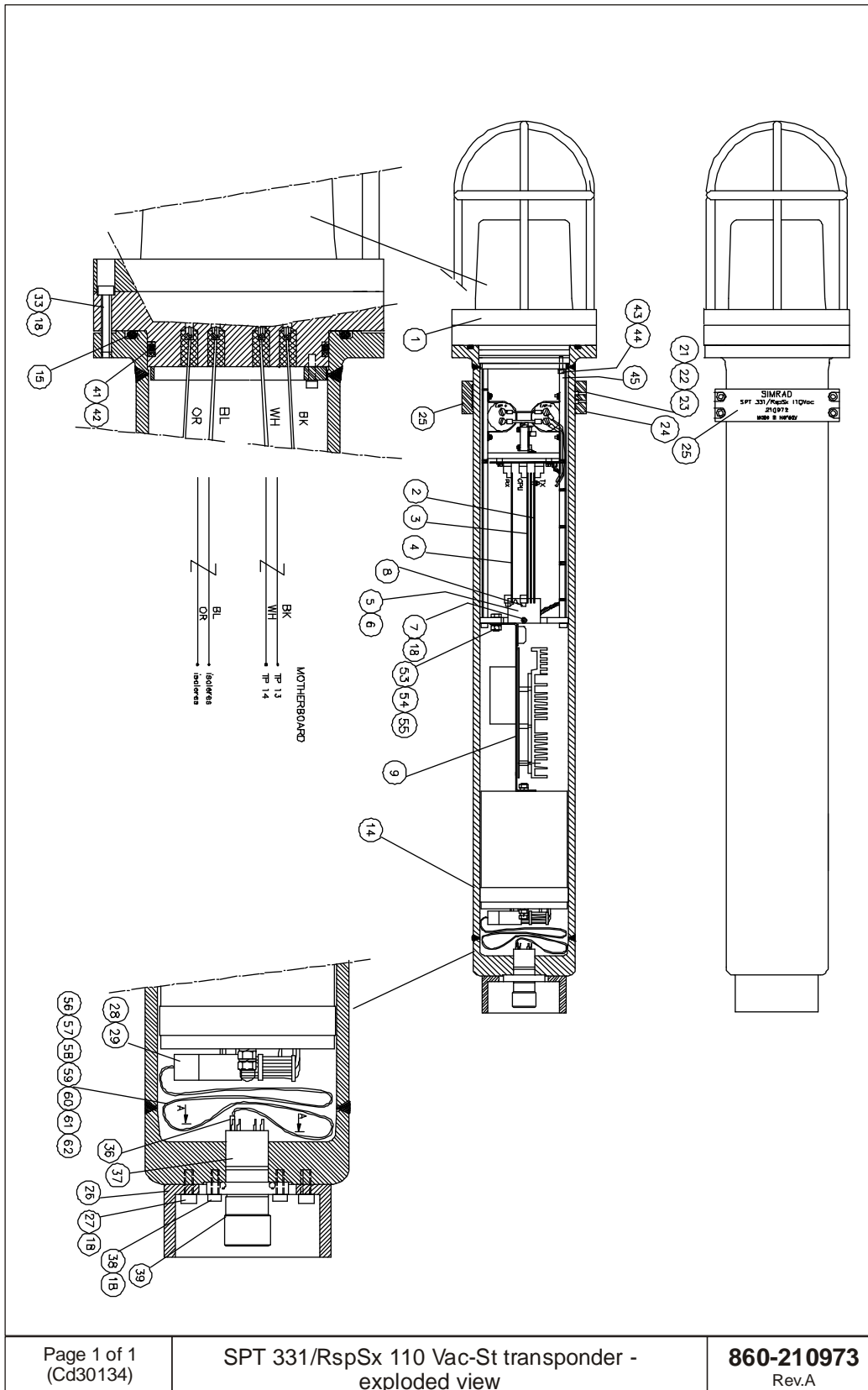

SPT 331 basic transponder

The SPT 331 basic transponder can also be delivered with stainless steel housing, see page 89.

Complete transponder without battery

Part no.	Item name	Drw. ref.	No. in sys.
-	Technical data	Drw. pos.	Rec.spares
102-215801	SPT 331 Transponder complete without battery	Figure page 107	1
-	All main modules are included (except for battery)	N/A	-

Standard battery

Part no.	Item name	Drw. ref.	No. in sys.
-	Technical data	Drw. pos.	Rec.spares
290-103053	Battery pack (lithium)	Figure page 107	1
-	L10/36 (15/40)	9	-

Other available batteries

→ Refer to the table on page 88.

Main modules

Main modules for the SPT 331 basic aluminium transponder.

Part no.	Item name	Drw. ref.	No. in sys.
-	Technical data	Drw. pos.	Rec.spares
312-089983	SPT 331 Transducer	Figure page 107	1
-	-	1	-
299-102851	Electronic chassis	Figure page 107	1
-	Motherboard, Rxamp board and sensors (if used) are included	28	-
382-210413	Tx board	Figure page 107	1
-	-	2	-
382-083551	Microcontroller board	Figure page 107	1
-	-	3	-
382-083602	Rx board	Figure page 107	1
-	-	4	-
599-112057	Housing	Figure page 107	1
-	Coated	14	-
499-215049	Bottom end cap	Figure page 107	1
-	-	26	-

Accessories

→ Refer to the table on page 87.

SPT 331/R transponder

The SPT 331/R transponder can also be delivered with stainless steel housing, see page 91.

Complete transponder without battery

Part no.	Item name	Drw. ref.	No. in sys.
-	Technical data	Drw. pos.	Rec.spares
102-215800	SPT 331/R Transponder complete without battery	Figure page 107	1
-	All main modules are included (except for battery)	N/A	-

Standard battery

Part no.	Item name	Drw. ref.	No. in sys.
-	Technical data	Drw. pos.	Rec.spares
290-103053	Battery pack (lithium)	Figure page 107	1
-	L10/36 (15/40)	9	-

Other available batteries

→ Refer to the table on page 88.

Main modules

Main modules for the SPT 331/R aluminium transponder.

Part no.	Item name	Drw. ref.	No. in sys.
-	Technical data	Drw. pos.	Rec.spares
312-214878	SPT 331/R Transducer	Figure page 107	1
-	-	1	-
299-102851	Electronic chassis	Figure page 107	1
-	Motherboard, Rxamp board and sensors (if used) are included	28	-
382-210413	Tx board	Figure page 107	1
-	-	2	-
382-083602	Rx board	Figure page 107	1
-	-	4	-
382-083551	Microcontroller board	Figure page 107	1
-	-	3	-
599-214886	Housing	Figure page 107	1
-	Coated	14	-
499-213700	Release mechanism	Figure page 107	1
-	(Ref. page 122)	-	-

Accessories

→ Refer to the table on page 87.

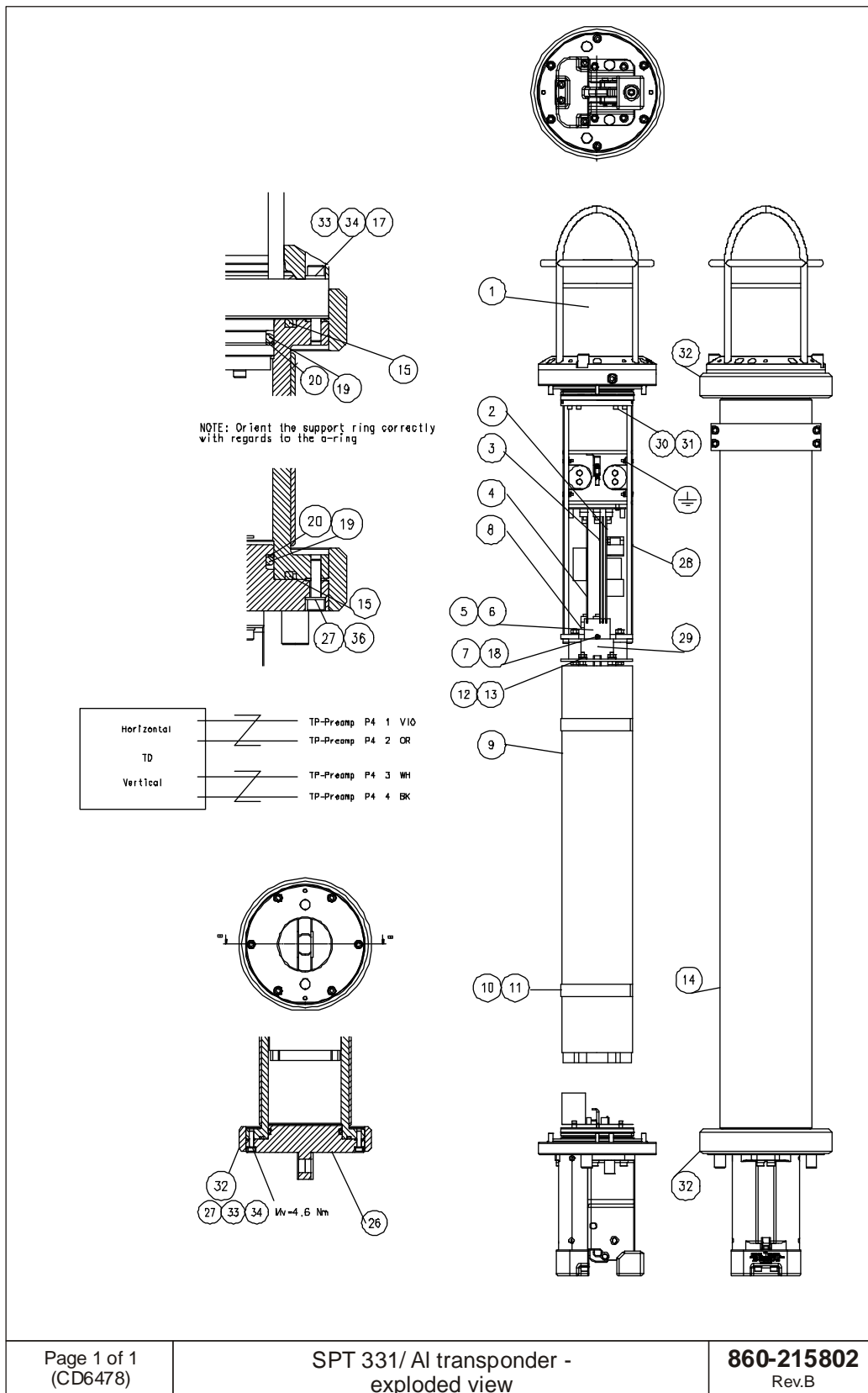

SPT 331/RspSx 110 Vac transponder

The SPT 331/RspSx 110 Vac transponder can also be delivered with stainless steel housing, see page 102.

Complete transponder without battery

Part no.	Item name	Drw. ref.	No. in sys.
-	Technical data	Drw. pos.	Rec.spares
102-216131	SPT 331/RptSx 110 Vac Transponder complete without backup battery	Figure page 109	1
-	All main modules are included (except for backup battery)	N/A	-

Battery

Part no.	Item name	Drw. ref.	No. in sys.
-	Technical data	Drw. pos.	Rec.spares
290-102726	Battery pack (lithium)	Figure page 109	1
-	L1040 (3/11)	9	-

Main modules

Main modules for the SPT 331/RspSx 110 Vac aluminium transponder.

Part no.	Item name	Drw. ref.	No. in sys.
-	Technical data	Drw. pos.	Rec.spares
312-214878	SPT 331 Transducer	Figure page 109	1
-	-	1	-
299-211002	Electronic chassis (short)	Figure page 109	1
-	Motherboard, Rxamp board and sensors (if used) are included	27	-
382-102852	Tx board	Figure page 109	1
-	-	2	-
382-083551	Microcontroller board	Figure page 109	1
-	-	3	-
382-102853	Rx board	Figure page 109	1
-	-	4	-
107-103000	Power module	Figure page 109	1
-	-	9	-
370-087144	UW receptacle	Figure page 109	1
-	10.00.2.07.2.10 7- pins	37	-
379-087453	Protection cap	Figure page 109	1
-	10.20.2.00.01	39	-

Accessories

→ Refer to the table on page 87.

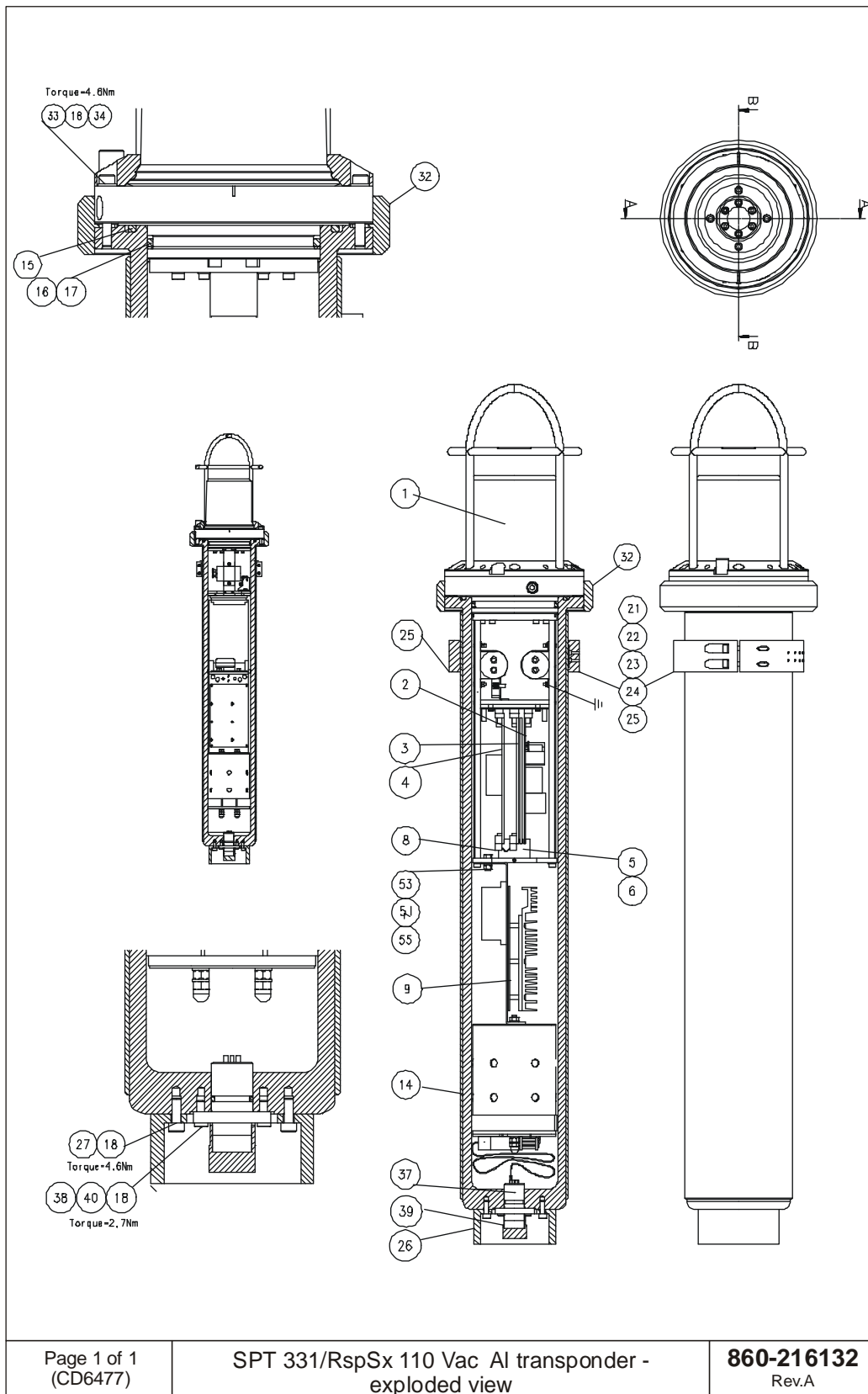

SPT 133/RspSx 110 Vac SU-St transponder

This section includes parts for the two units (housing and transducer) of the SPT 133/RspSx 110 Vac SU-St transponder.

Complete transponder without battery

Part no.	Item name	Drw. ref.	No. in sys.
-	Technical data	Drw. pos.	Rec.spares
102-210480	SPT 133/DTRspSx 110 Vac SU-St Transponder complete without backup battery	Figure page 111	1
-	All main modules are included (except for backup battery)	N/A	-

Battery

Part no.	Item name	Drw. ref.	No. in sys.
-	Technical data	Drw. pos.	Rec.spares
290-102726	Battery pack (lithium)	Figure page 109	1
-	L1040 (3/11)	9	-

Main modules

Main modules for the SPT 133/RspSx 110 Vac SU-St transponder.

Part no.	Item name	Drw. ref.	No. in sys.
-	Technical data	Drw. pos.	Rec.spares
299-210840	Electronic chassis (short)	Figure page 111	1
-	Motherboard, Rxamp board and sensors (if used) are included	45	-
382-101205	Tx board	Figure page 111	1
-	-	2	-
382-083551	Microcontroller board	Figure page 111	1
-	-	3	-
382-210851	Rx board	Figure page 111	1
-	-	4	-
599-210482	Housing	Figure page 111	1
-	(short)	14	-
107-210842	Power module	Figure page 111	1
-	-	9	-
370-086570	UW receptacle base	Figure page 111	1
-	10.00.3.12.1.10 12 pins	10	-
379-087454	Protection cap	Figure page 111	1
-	10.20.3.00.01 12 pins	11	-
370-086656	UW receptacle - top	Figure page 111	1
-	10.00.2.07.1.10 7 pins	37	-
379-087453	Protection cap	Figure page 111	1
-	10.20.2.00.01 7 pins	39	-

Accessories

→ Refer to the table on page 87.

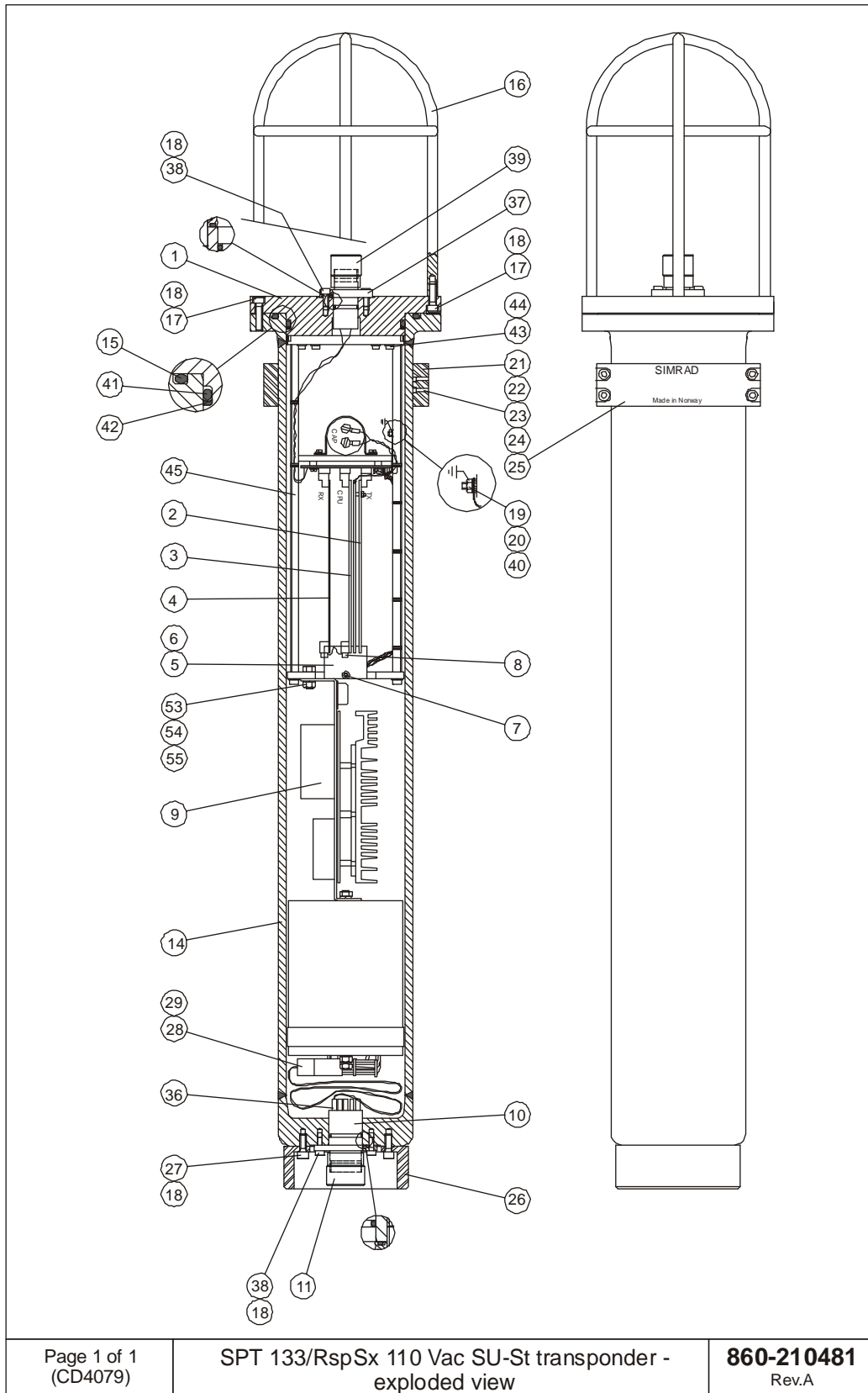

Transducer unit

This list includes the common spare parts for the transducer unit of the SPT 133/RspSx 110 Vac SU-St transponder.

Part no.	Item name	Drw. ref.	No. in sys.
-	Technical data	Drw. pos.	Rec.spares
100-210880	SPT 133/DTRspSx 110 Vac SU-St transducer unit	Figure 37	1
-	-	N/A	-
370-086656	UW receptacle	-	-
-	10.00.2.07.1.10 7 pins	N/A	-

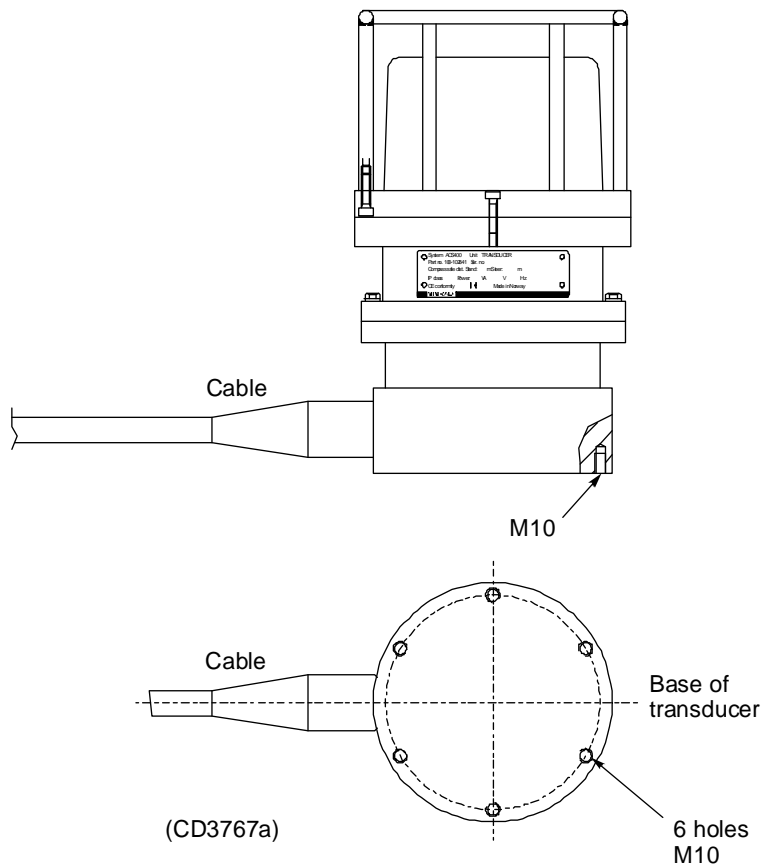

Figure 37 Transducer unit of the SPT 133/RspSx 110 Vac SU-St transponder

MPT 339/St transponder

Complete transponder without battery

Part no.	Item name	Drw. ref.	No. in sys.
-	Technical data	Drw. pos.	Rec.spares
102-089843	MPT 339/St Transponder complete without battery	Figure page 115	1
-	All main modules are included (except for battery)	N/A	-

Battery

Part no.	Item name	Drw. ref.	No. in sys.
-	Technical data	Drw. pos.	Rec.spares
290-089592	Battery pack (lithium)	Figure page 115	1
-	L10/50 (12/42)	9	-

Main modules

Main modules for the MPT 339/St stainless steel transponder.

Part no.	Item name	Drw. ref.	No. in sys.
-	Technical data	Drw. pos.	Rec.spares
312-089845	MPT 339/St Transducer	Figure page 115	1
-	-	1	-
299-089696	Electronic chassis	Figure page 115	1
-	Motherboard, Rxamp board and sensors (if used) are included	27	-
382-089738	Tx board	Figure page 115	1
-	-	2	-
382-083551	Microcontroller board	Figure page 115	1
-	-	3	-
382-083602	Rx board	Figure page 115	1
-	-	4	-
599-112057	Housing w/flanges	Figure page 115	1
-	-	14	-
599-089836	Bottom end cap	Figure page 115	1
-	-	26	-

Accessories

→ Refer to the table on page 87.

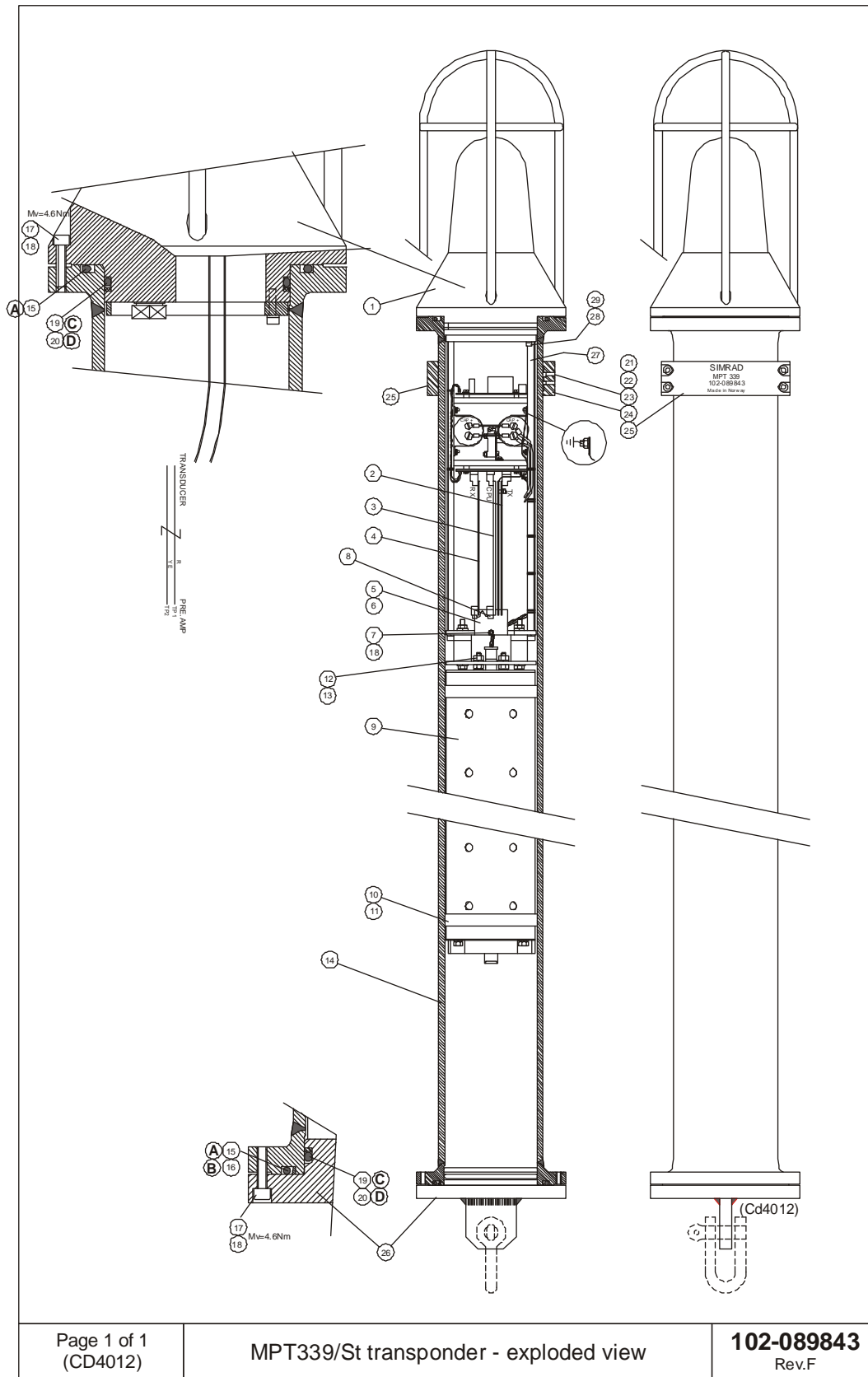

MPT 339/DTR-St transponder

The standard MPT 339/DTR transponder is delivered with aluminium housing, see page 120.

Complete transponder without battery

Part no.	Item name	Drw. ref.	No. in sys.
-	Technical data	Drw. pos.	Rec.spares
102-089689	MPT 339/DTR-St Transponder complete without battery	Figure page 117	1
-	All main modules are included (except for battery)	N/A	-

Battery

Part no.	Item name	Drw. ref.	No. in sys.
-	Technical data	Drw. pos.	Rec.spares
290-089592	Battery pack (lithium)	Figure page 117	1
-	L10/50 (12/42)	9	-

Main modules

Main modules for the MPT 339/DTR-St stainless steel transponder.

Part no.	Item name	Drw. ref.	No. in sys.
-	Technical data	Drw. pos.	Rec.spares
312-089691	MPT 339/DTR-St Transducer	Figure page 117	1
-	-	1	-
299-089696	Electronic chassis	Figure page 117	1
-	Motherboard, Rxamp board and sensors (1) (if used) are included	28	-
382-089738	Tx board	Figure page 117	1
-	-	2	-
382-083551	Microcontroller board	Figure page 117	1
-	-	3	-
382-083602	Rx board	Figure page 117	1
-	-	4	-
599-112057	Housing w/flanges	Figure page 117	1
-	-	14	-
499-089594	Release mechanism	Figure page 117	1
-	(Separate list ref. page 93)	26	-

1 Separate DT sensor, see page 88.

Accessories

→ Refer to the table on page 87.

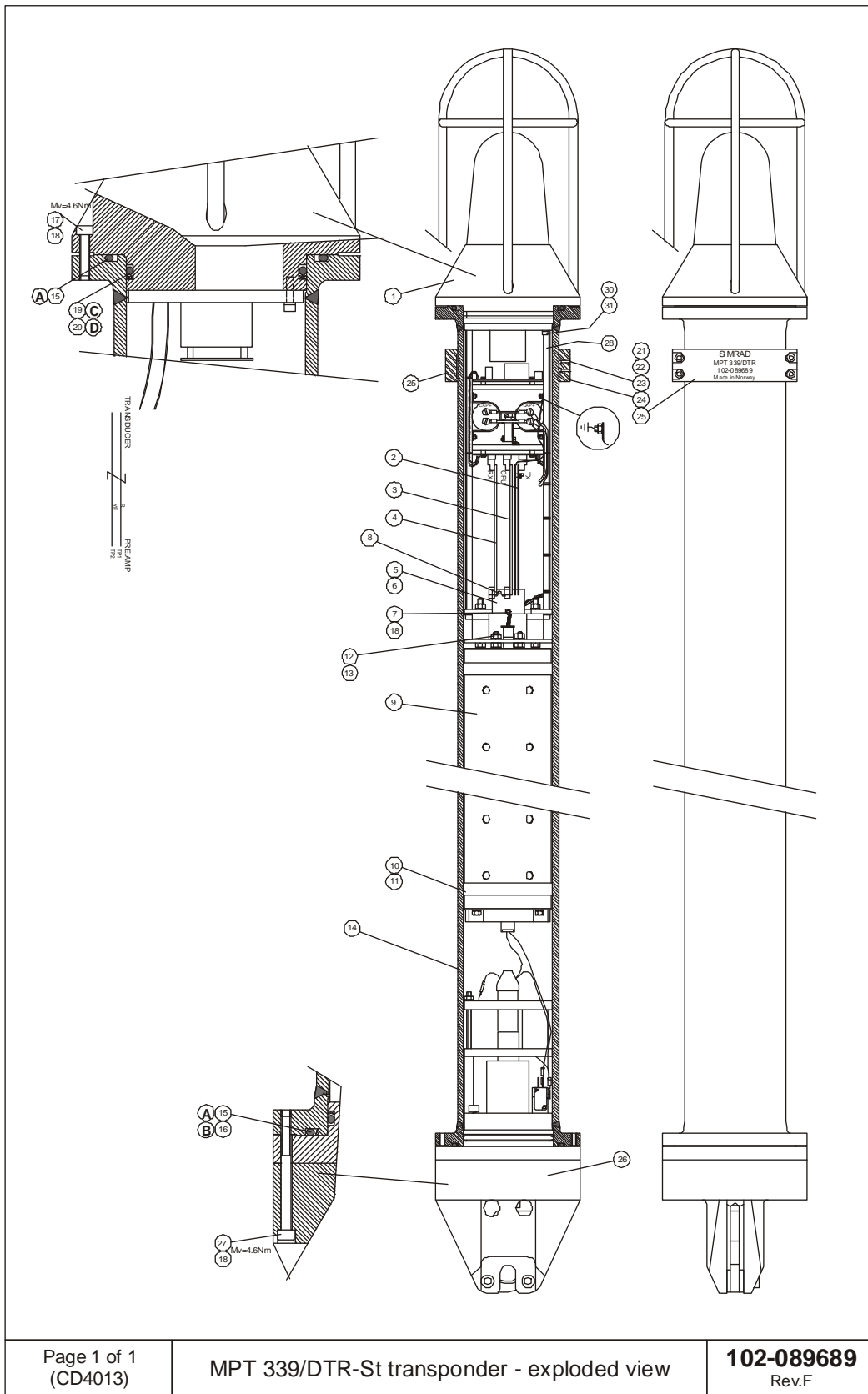

MPT 339/DTRspSx 110 Vac-St transponder

Complete transponder without battery

Part no.	Item name	Drw. ref.	No. in sys.
-	Technical data	Drw. pos.	Rec.spares
102-102489	MPT 339/DTRspSx 110 Vac-St Transponder complete without backup battery	Figure page 119	1
-	All main modules are included (except for backup battery)	N/A	-

Battery

Part no.	Item name	Drw. ref.	No. in sys.
-	Technical data	Drw. pos.	Rec.spares
290-102726	Battery pack (lithium)	Figure page 109	1
-	L1040 (3/11)	9	-

Main modules

Main modules for the MPT 339/DTRspSx 110 Vac- St transponder.

Part no.	Item name	Drw. ref.	No. in sys.
-	Technical data	Drw. pos.	Rec.spares
312-089691	MPT 339/DTRspSx 110 Vac-St Transducer	Figure page 119	1
-	-	1	-
299-103087	Electronic chassis (short)	Figure page 119	1
-	Motherboard, Rxamp board and sensors (1) (if used) are included	45	-
382-089738	Tx board	Figure page 119	1
-	-	2	-
382-083551	Microcontroller board	Figure page 119	1
-	-	3	-
382-1083602	Rx board	Figure page 119	1
-	-	4	-
107-103000	Power module	Figure page 119	1
-	-	9	-
599-112212	Housing	Figure page 119	1
-	(short)	14	-
599-112275	Protection cap	Figure page 119	1
-	-	26	-
379-087453	Sealing cap	Figure page 119	1
-	-	39	-
370-086656	UV receptacle	Figure page 119	1
-	10.00.2.07.1.10 7 pins	37	-

1 Separate DT sensor, see page 88.

Accessories

→ Refer to the table on page 87.

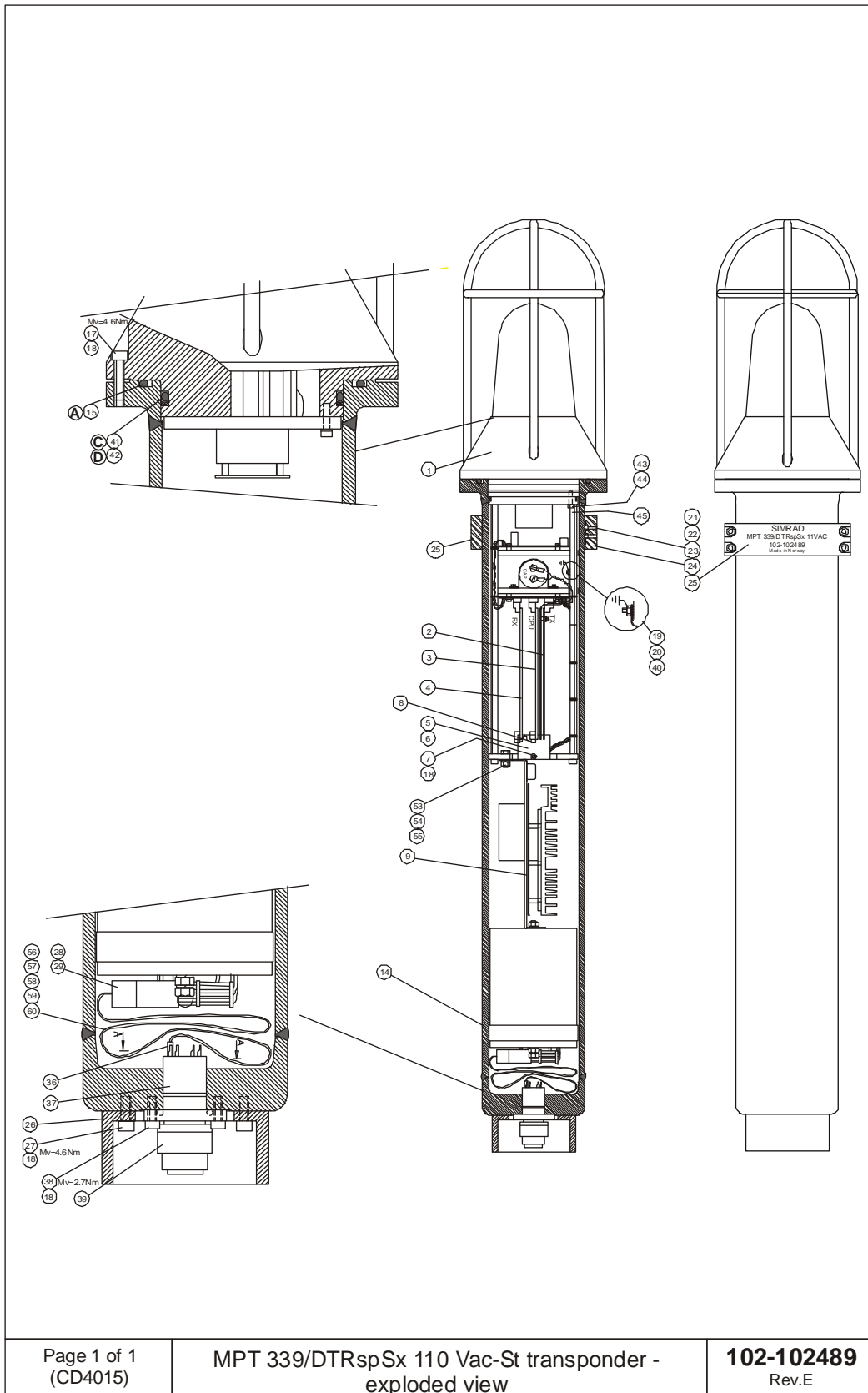

MPT 339/DTR transponder

The MPT 339/DTR transponder can also be delivered with stainless steel housing. see page 116.

Complete transponder without battery

Part no.	Item name	Drw. ref.	No. in sys.
-	Technical data	Drw. pos.	Rec.spares
102-216121	MPT 339/DTR Transponder complete without battery	Figure page 121	1
-	All main modules are included (except for battery)	N/A	-

Battery

Part no.	Item name	Drw. ref.	No. in sys.
-	Technical data	Drw. pos.	Rec.spares
290-089592	Battery pack (lithium)	Figure page 121	1
-	L10/50 (12/42)	9	-

Main modules

Main modules for the MPT 339/DTR aluminium transponder.

Part no.	Item name	Drw. ref.	No. in sys.
-	Technical data	Drw. pos.	Rec.spares
312-216113	MPT 339 /DTR Transducer	Figure page 121	1
-	-	1	-
299-089696	Electronic chassis	Figure page 121	1
-	Motherboard, Rxamp board and sensors (1) (if used) are included	28	-
382-089738	Tx board	Figure page 121	1
-	-	2	-
382-083551	Microcontroller board	Figure page 121	1
-	-	3	-
382-083602	Rx board	Figure page 121	1
-	-	4	-
599-214886	Housing	Figure page 121	1
-	Coated	14	-
499-213700	Release mechanism	Figure page 121	1
-	(Ref. page 122)	26	-

1 Separate DT sensor, see page 88.

Accessories

→ Refer to the table on page 87.

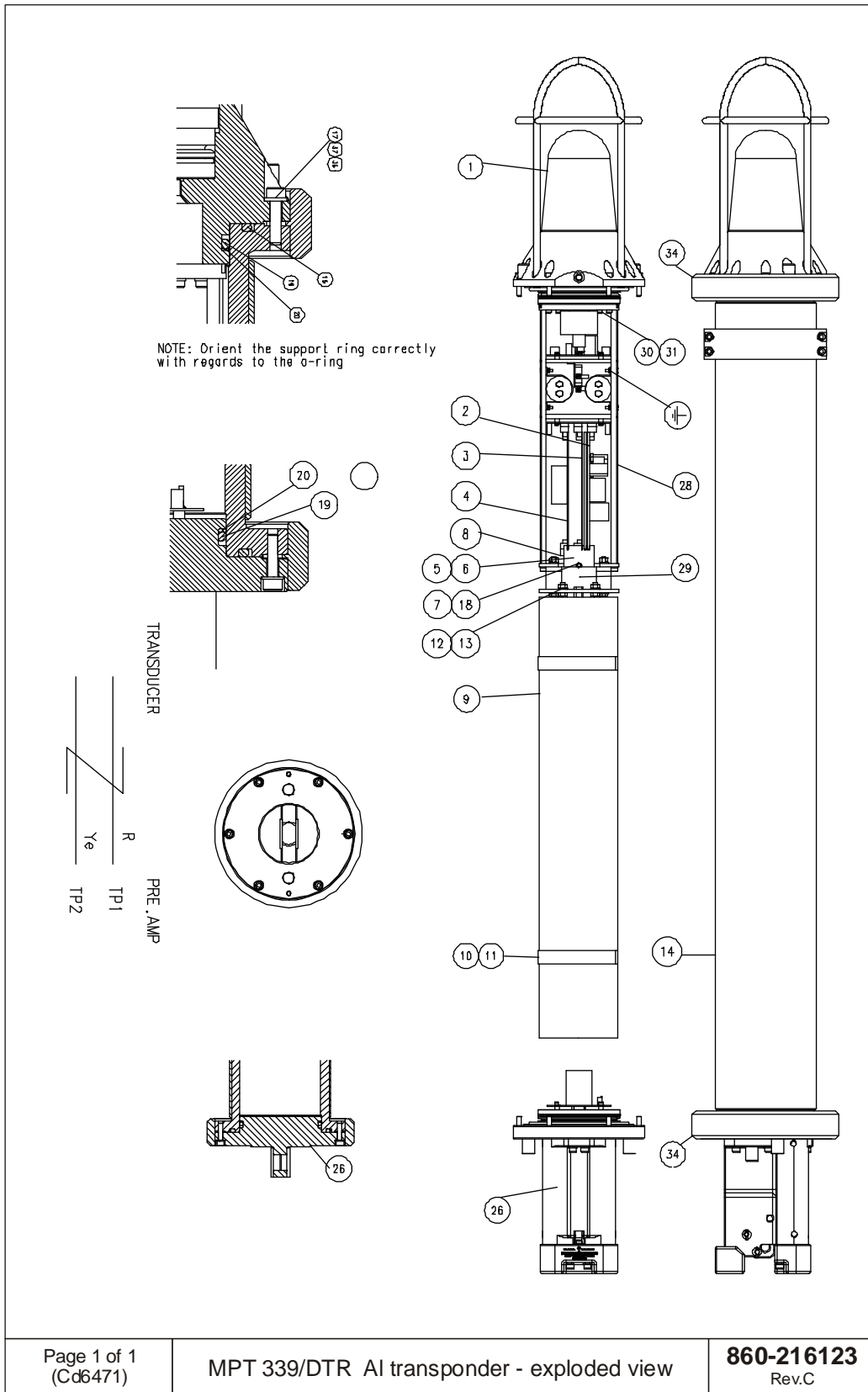

Magnetic release mechanism

Complete unit

Part no.	Item name	Drw. ref.	No. in sys.
-	Technical data	Drw. pos.	Rec.spares
499-213700	Release unit complete	Figure page 122	1
-	-	N/A	-

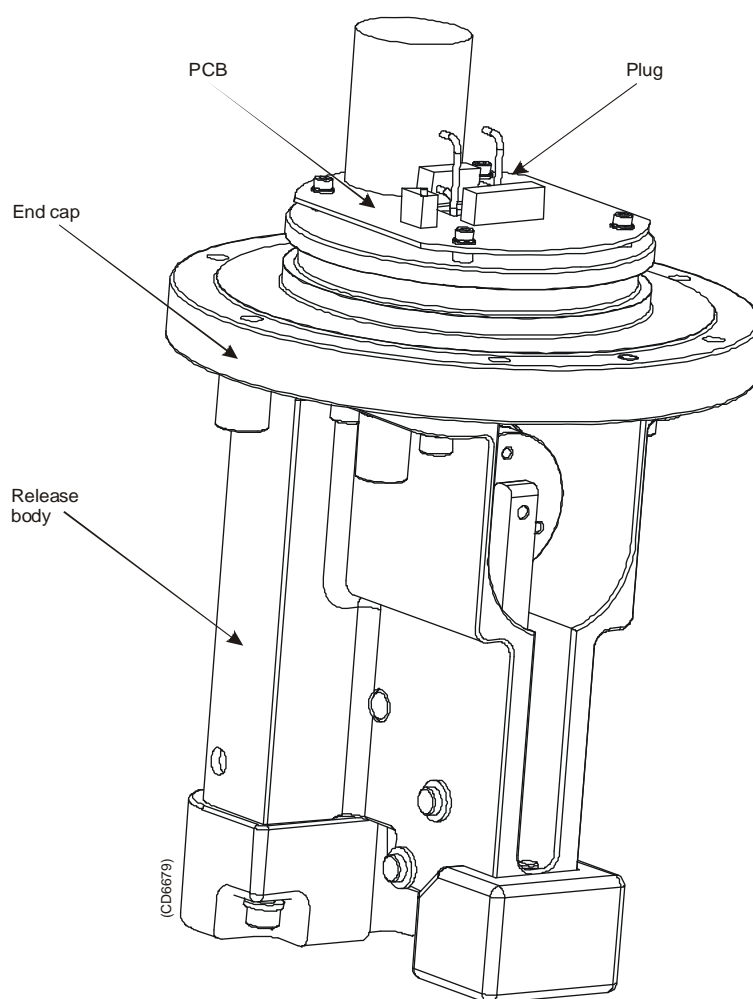

Figure 38 Magnetic release mechanism -
for Aluminium transponders

MPT 339/DT transponder

Complete transponder without battery

Part no.	Item name	Drw. ref.	No. in sys.
-	Technical data	Drw. pos.	Rec.spares
102-216122	MPT 339/DT Transponder complete without battery	Figure page 121	1
-	All main modules are included (except for battery)	N/A	-

Battery

Part no.	Item name	Drw. ref.	No. in sys.
-	Technical data	Drw. pos.	Rec.spares
290-089592	Battery pack (lithium)	Figure page 121	1
-	L10/50 (12/42)	9	-

Main modules

Main modules for the MPT 339/DT aluminium transponder.

Part no.	Item name	Drw. ref.	No. in sys.
-	Technical data	Drw. pos.	Rec.spares
312-216113	MPT 339 /DT Transducer	Figure page 121	1
-	-	1	-
299-089696	Electronic chassis	Figure page 121	1
-	Motherboard, Rxamp board and sensors (1) (if used) are included	28	-
382-089738	Tx board	Figure page 121	1
-	-	2	-
382-083551	Microcontroller board	Figure page 121	1
-	-	3	-
382-083602	Rx board	Figure page 121	1
-	-	4	-
290-089592	Battery pack (lithium)	Figure page 121	1
-	L10/50 (12/42)	9	-
599-214886	Housing	Figure page 121	1
-	Coated	14	-

1 Separate DT sensor, see page 88.

Accessories

→ Refer to the table on page 87.

MPT 331/DTDuB-St transponder

Note *A common figure is provided for the DTDuB and the DTRDuB transponders, see page 125.*

The standard MPT 331/DuB-St transponder is delivered with aluminium housing, see page 127.

Complete transponder

Part no.	Item name	Drw. ref.	No. in sys.
-	Technical data	Drw. pos.	Rec.spares
102-210702	MPT 331/DTDuB-St Transponder complete	Figure page 125	1
-	All main modules are included	N/A	-

Main modules

Main modules for the MPT 331/DTDuB-St stainless steel transponder.

Part no.	Item name	Drw. ref.	No. in sys.
-	Technical data	Drw. pos.	Rec.spares
312-113363	MPT 331/DTDuB-St Transducer	Figure page 125	1
-	-	1	-
299-210414	Electronic chassis	Figure page 125	1
-	Motherboard, Rxamp board and sensors (1) (if used) are included	28	-
382-210413	Tx board	Figure page 125	1
-	-	2	-
382-083551	Microcontroller board	Figure page 125	1
-	-	3	-
382-211016	Rx board	Figure page 125	1
-	-	4	-
290-103053	Battery pack (lithium)	Figure page 125	1
-	L10/36 (15/40)	9	-
599-112057	Housing w/flanges	Figure page 125	1
-	-	14	-
599-089836	Bottom end cap	Figure page 125	1
-	-	26	-

1 Separate DT sensor, see page 88.

Accessories

→ Refer to the table on page 87.

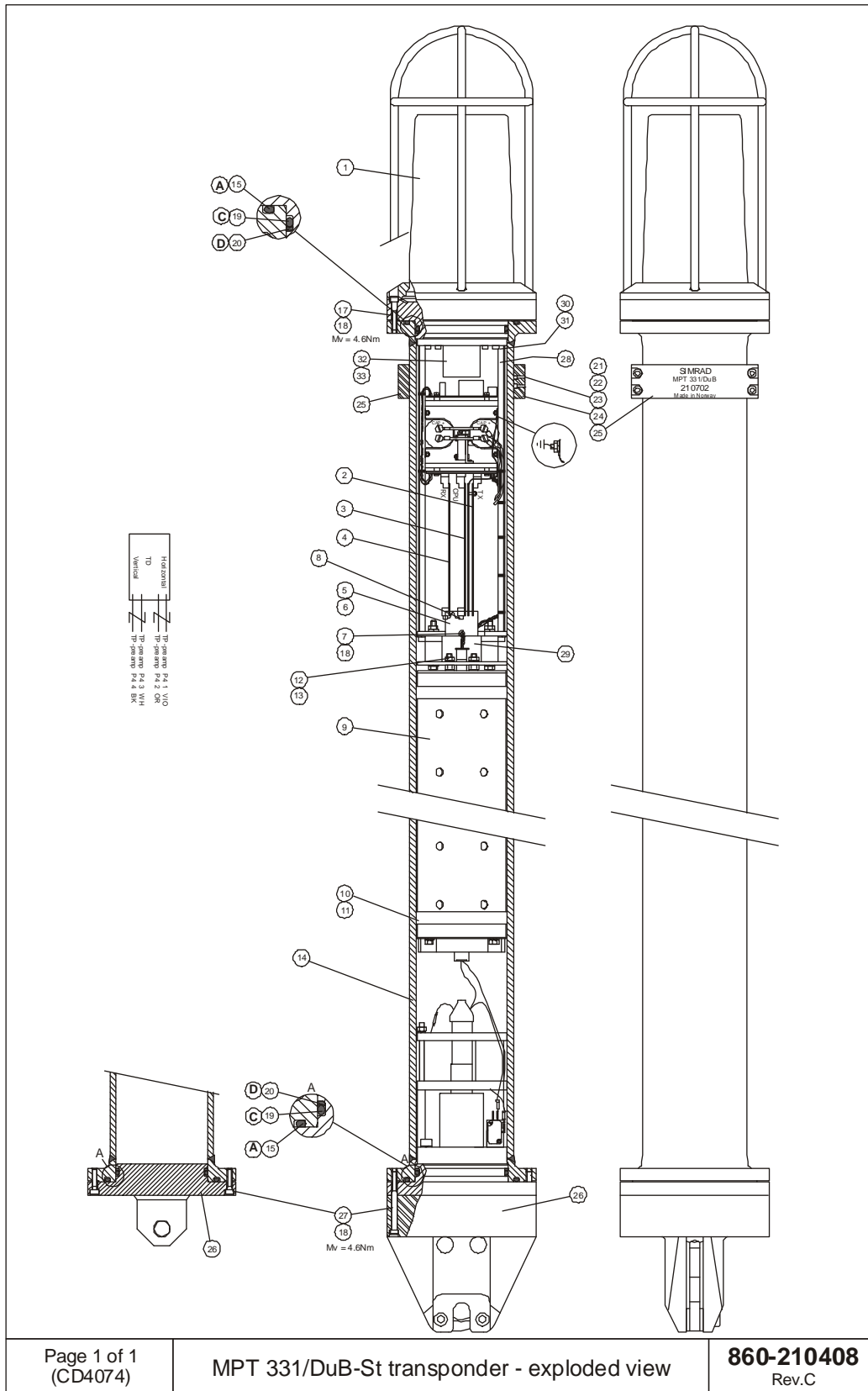

MPT 331/DTRDuB-St transponder

Note *A common figure is provided for the DTDuB and the DTRDuB transponders, see page 125.*

The standard MPT 331/DTDuB transponder is delivered with aluminium housing, see page 129.

Complete transponder without battery

Part no.	Item name	Drw. ref.	No. in sys.
-	Technical data	Drw. pos.	Rec.spares
102-210407	MPT 331/DTRDuB-St Transponder complete without battery	Figure page 125	1
-	All main modules are included (except for battery)	N/A	-

Standard battery

Part no.	Item name	Drw. ref.	No. in sys.
-	Technical data	Drw. pos.	Rec.spares
290-103053	Battery pack (lithium)	Figure page 125	1
-	L10/36 (15/40)	9	-

Other available batteries

→ *Refer to the table on page 88.*

Main modules

Main modules for the MPT 331/DTRDuB-St transponder.

Part no.	Item name	Drw. ref.	No. in sys.
-	Technical data	Drw. pos.	Rec.spares
312-113363	MPT 331/DTRDuB-St Transducer	Figure page 125	1
-	-	1	-
299-210414	Electronic chassis	Figure page 125	1
-	Motherboard, Rxamp board and sensors (if used) are included	28	-
382-210413	Tx board	Figure page 125	1
-	-	2	-
382-083551	Microcontroller board	Figure page 125	1
-	-	3	-
382-211016	Rx board	Figure page 125	1
-	-	4	-
499-089594	Release mechanism	Figure page 125	1
-	(Separate list ref. page 93)	26	-

1 Separate DT sensor, see page 88.

MPT 331/DTDuB transponder

Note *A common figure is provided for the DTDuB and the DTRDuB transponders, see page 128.*

The MPT 331/DTDub transponder can also be delivered with stainless steel housing, see page 124.

Complete transponder without battery

Part no.	Item name	Drw. ref.	No. in sys.
-	Technical data	Drw. pos.	Rec.spares
102-215798	MPT 331/DTDuB Transponder complete without battery	Figure page 128	1
-	All main modules are included (except for battery)	N/A	-

Standard battery

Part no.	Item name	Drw. ref.	No. in sys.
-	Technical data	Drw. pos.	Rec.spares
290-103053	Battery pack (lithium)	Figure page 128	1
-	L10/36 (15/40)	9	-

Other available batteries

→ *Refer to the table on page 88.*

Main modules

Main modules for the MPT 331/DTRDuB aluminium transponder.

Part no.	Item name	Drw. ref.	No. in sys.
-	Technical data	Drw. pos.	Rec.spares
312-214880	MPT 331/DTDuB Transducer	Figure page 128	1
-	-	1	-
299-210414	Electronic chassis	Figure page 128	1
-	Motherboard, Rxamp board and sensors (1) (if used) are included	28	-
382-210413	Tx board	Figure page 128	1
-	-	2	-
382-083551	Microcontroller board	Figure page 128	1
-	-	3	-
382-211016	Rx board	Figure page 128	1
-	-	4	-

1 Separate DT sensor, refer to page 88.

Accessories

→ *Refer to the table on page 87.*

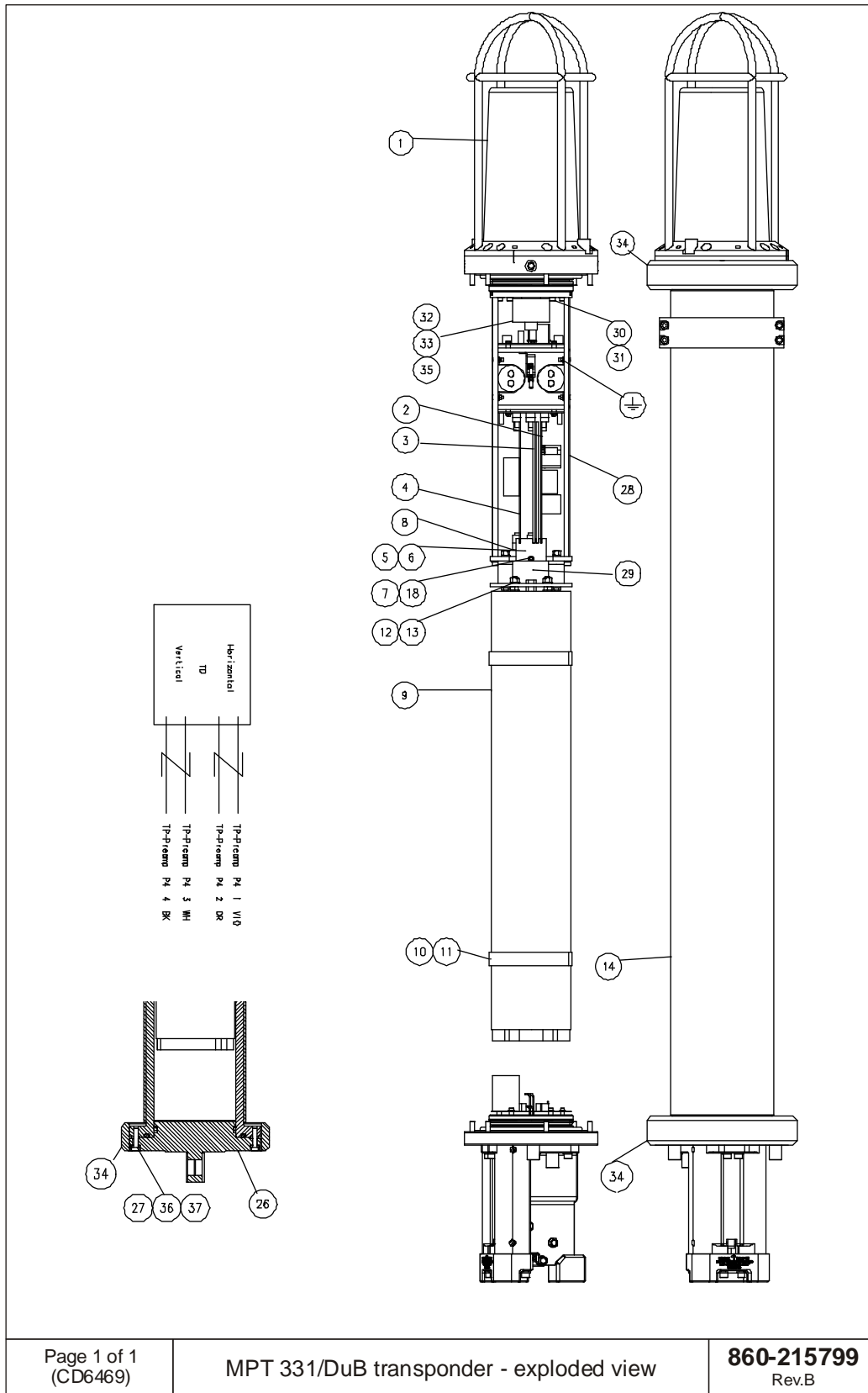

MPT 331/DTRDuB transponder

Note *A common figure is provided for the DTDuB and the DTRDuB aluminium transponders, see page 128.*

The MPT 33R/DTRDuB transponder can also be delivered with stainless steel housing, see page 126.

Complete transponder without battery

Part no.	Item name	Drw. ref.	No. in sys.
-	Technical data	Drw. pos.	Rec.spares
102-215797	MPT 331/DTRDuB Transponder complete without battery	Figure page 128	1
-	All main modules are included (except for battery)	N/A	-

Standard battery

Part no.	Item name	Drw. ref.	No. in sys.
-	Technical data	Drw. pos.	Rec.spares
290-103053	Battery pack (lithium)	Figure page 128	1
-	L10/36 (15/40)	9	-

Other available batteries

→ *Refer to the table on page 88.*

Main modules

Main modules for the MPT 331/DTRDuB aluminium transponder.

Part no.	Item name	Drw. ref.	No. in sys.
-	Technical data	Drw. pos.	Rec.spares
312-214880	MPT 331/DTRDuB Transducer	Figure page 128	1
-	-	1	-
299-210414	Electronic chassis	Figure page 128	1
-	Motherboard, Rxamp board and sensors (1) (if used) are included	28	-
382-210413	Tx board	Figure page 128	1
-	-	2	-
382-083551	Microcontroller board	Figure page 128	1
-	-	3	-
382-211016	Rx board	Figure page 128	1
-	-	4	-
499-213700	Release mechanism	Figure page 128	1
-	(Ref. page 122)	-	-

1 Separate DT sensor, see page 88.

Accessories

→ *Refer to the table on page 87.*

MPT 139/St transponder

Complete transponder without battery

Part no.	Item name	Drw. ref.	No. in sys.
-	Technical data	Drw. pos.	Rec.spares
102-089831	MPT 139/St Transponder complete without battery	Figure page 131	1
-	All main modules are included (except for battery)	N/A	-

Battery

Part no.	Item name	Drw. ref.	No. in sys.
-	Technical data	Drw. pos.	Rec.spares
290-089592	Battery pack (lithium)	Figure page 131	1
-	L10/50 (12/42)	9	-

Main modules

Main modules for the MPT 139/St stainless steel transponder.

Part no.	Item name	Drw. ref.	No. in sys.
-	Technical data	Drw. pos.	Rec.spares
312-089837	MPT 139/St Transducer	Figure page 131	1
-	-	1	-
299-089585	Electronic chassis	Figure page 131	1
-	Motherboard, Rxamp board and sensors (if used) are included	27	-
382-101205	Tx board	Figure page 131	1
-	-	2	-
382-089502	Rx board	Figure page 131	1
-	-	4	-
382-083551	Microcontroller board	Figure page 131	1
-	-	3	-
599-112057	Housing w/flanges	Figure page 131	1
-	-	14	-
599-089836	Bottom end cap	Figure page 131	1
-	-	26	-

Accessories

→ Refer to the table on page 87.

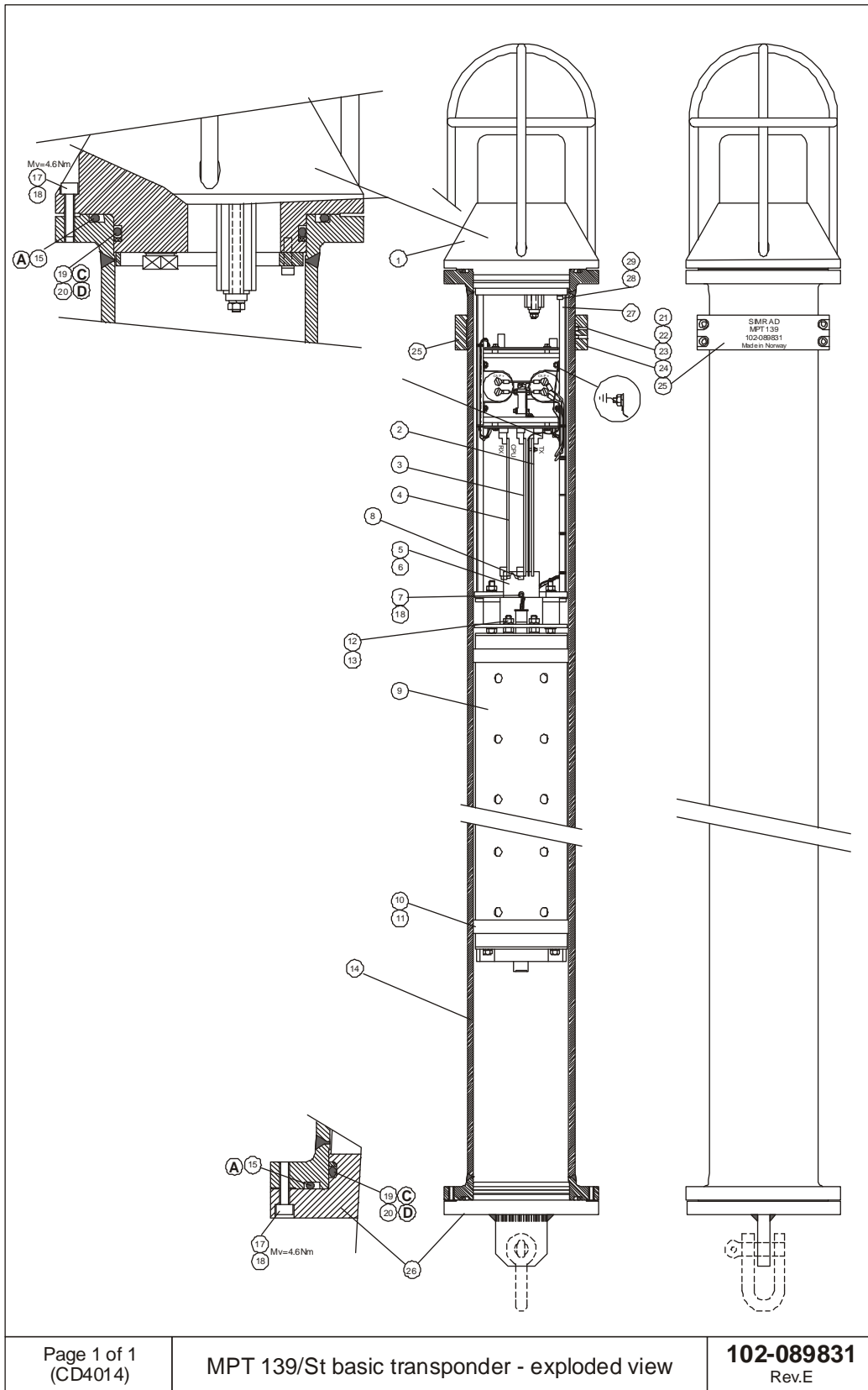

MPT 139/DT-St transponder

Complete transponder without battery

Part no.	Item name	Drw. ref.	No. in sys.
-	Technical data	Drw. pos.	Rec.spares
102-089832	MPT 139/DT-St Transponder complete without battery	Figure page 133	1
-	All main modules are included (except for battery)	N/A	-

Battery

Part no.	Item name	Drw. ref.	No. in sys.
-	Technical data	Drw. pos.	Rec.spares
290-089592	Battery pack (lithium)	Figure page 133	1
-	L10/50 (12/42)	9	-

Main modules

Modules for the MPT 139/DT-St stainless steel transponder.

Part no.	Item name	Drw. ref.	No. in sys.
-	Technical data	Drw. pos.	Rec.spares
312-112273	MPT 139/DT-St Transducer	Figure page 133	1
-	-	1	-
299-089585	Electronic chassis	Figure page 133	1
-	Motherboard, Rxamp board and sensors (1) (if used) are included	27	-
382-101205	Tx board	Figure page 133	1
-	-	2	-
382-083551	Microcontroller board	Figure page 133	1
-	-	3	-
382-089502	Rx board	Figure page 133	1
-	-	4	-
599-112057	Housing w/flanges	Figure page 133	1
-	-	14	-
599-089836	Bottom end cap	Figure page 133	1
-	-	26	-

1 Separate DT sensor, see page 88.

Accessories

→ Refer to the table on page 87.

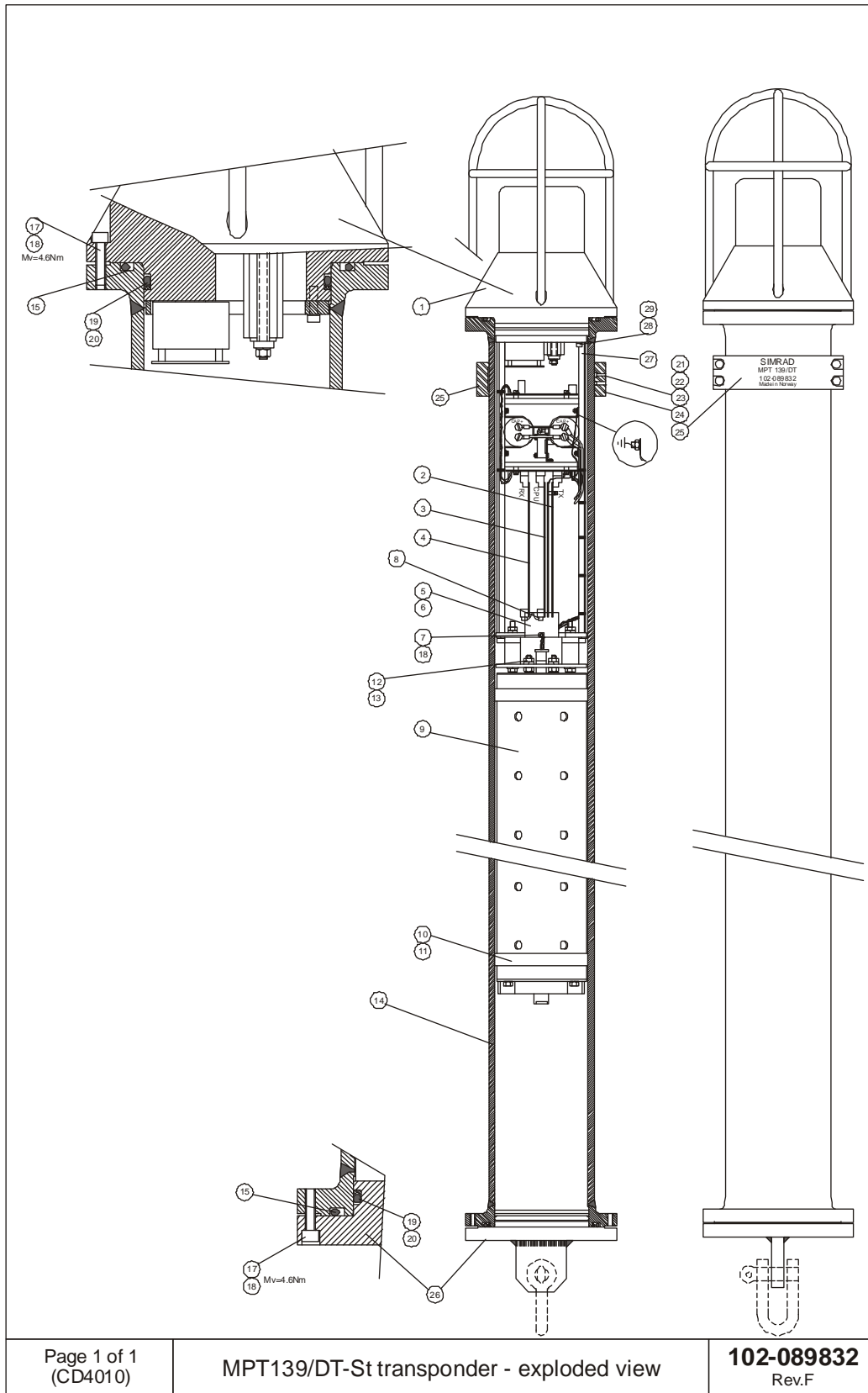

Page 1 of 1
(CD4010)

MPT139/DT-St transponder - exploded view

102-089832
Rev.F

MPT 139/DTR-St transponder

Complete transponder without battery

Part no.	Item name	Drw. ref.	No. in sys.
-	Technical data	Drw. pos.	Rec.spares
102-089591	MPT 139/DTR-St Transponder complete without battery	Figure page 135	1
-	All main modules are included (except for battery)	N/A	-

Battery

Part no.	Item name	Drw. ref.	No. in sys.
-	Technical data	Drw. pos.	Rec.spares
290-089592	Battery pack (lithium)	Figure page 135	1
-	L10/50 (12/42)	9	-

Main modules

Main modules for the MPT 139/DTR-St stainless steel transponder.

Part no.	Item name	Drw. ref.	No. in sys.
-	Technical data	Drw. pos.	Rec.spares
312-112273	MPT 139/DTR-St Transducer	Figure page 135	1
-	-	1	-
299-089585	Electronic chassis	Figure page 135	1
-	Motherboard, Rxamp board and sensors (1) (if used) are included	28	-
382-101205	Tx board	Figure page 135	1
-	-	2	-
382-083551	Microcontroller board	Figure page 135	1
-	-	3	-
382-083502	Rx board	Figure page 135	1
-	-	4	-
599-112057	Housing w/flanges	Figure page 135	1
-	-	14	-
499-089594	Release mechanism	Figure page 135	1
-	(figure page 101)	26	-

1 Separate DT sensor, see page 88.

Accessories

→ Refer to the table on page 87.

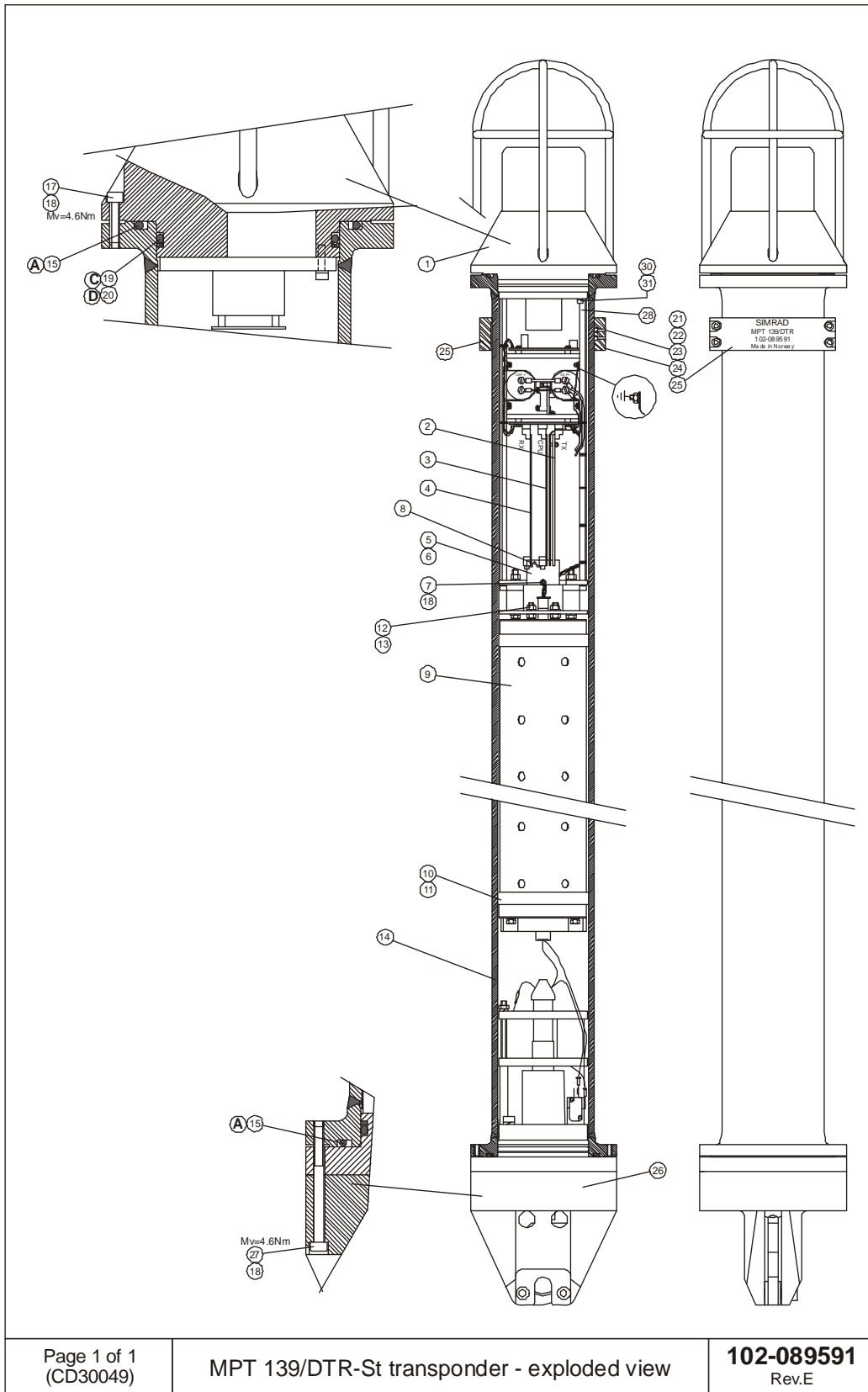

MPT 139/DTRspSx 110 Vac-St transponder

Complete transponder without battery

Part no.	Item name	Drw. ref.	No. in sys.
-	Technical data	Drw. pos.	Rec.spares
102-102542	MPT 139/DTRspSx 110 Vac-St Transponder complete without backup battery	Figure page 137	1
-	All main modules are included (except for backup battery)	N/A	-

Battery

Part no.	Item name	Drw. ref.	No. in sys.
-	Technical data	Drw. pos.	Rec.spares
290-102726	Battery pack (lithium)	Figure page 137	1
-	L1040 (3/11)	9	-

Main modules

Main modules for the MPT 139/DTRspSx 110 Vac-St transponder.

Part no.	Item name	Drw. ref.	No. in sys.
-	Technical data	Drw. pos.	Rec.spares
312-112273	MPT 139/DTRspSx 110 Vac-St transducer	Figure page 137	1
299-103086	Electronic chassis	Figure page 137	1
-	Motherboard, Rxamp board and sensors (1) (if used) are included	45	-
382-101205	Tx board	Figure page 137	1
--	-	2	-
382-083551	Microcontroller board	Figure page 137	1
-	-	3	-
382-089502	Rx board	Figure page 137	1
-	-	4	-
107-103000	Power module	Figure page 137	1
-	-	9	-
599-112212	Housing	Figure page 137	1
-	(short)	14	-
599-112275	Protection cap	Figure page 137	1
-	-	26	-
379-087453	Sealing cap	Figure page 137	1
-	10.20.2.00.01	39	-
370-086656	UW receptacle	Figure page 137	1
-	10.00.2.07.1.10 7 pins	37	-

1 Separate DT sensor, see page 88.

Accessories

→ Refer to the table on page 87.

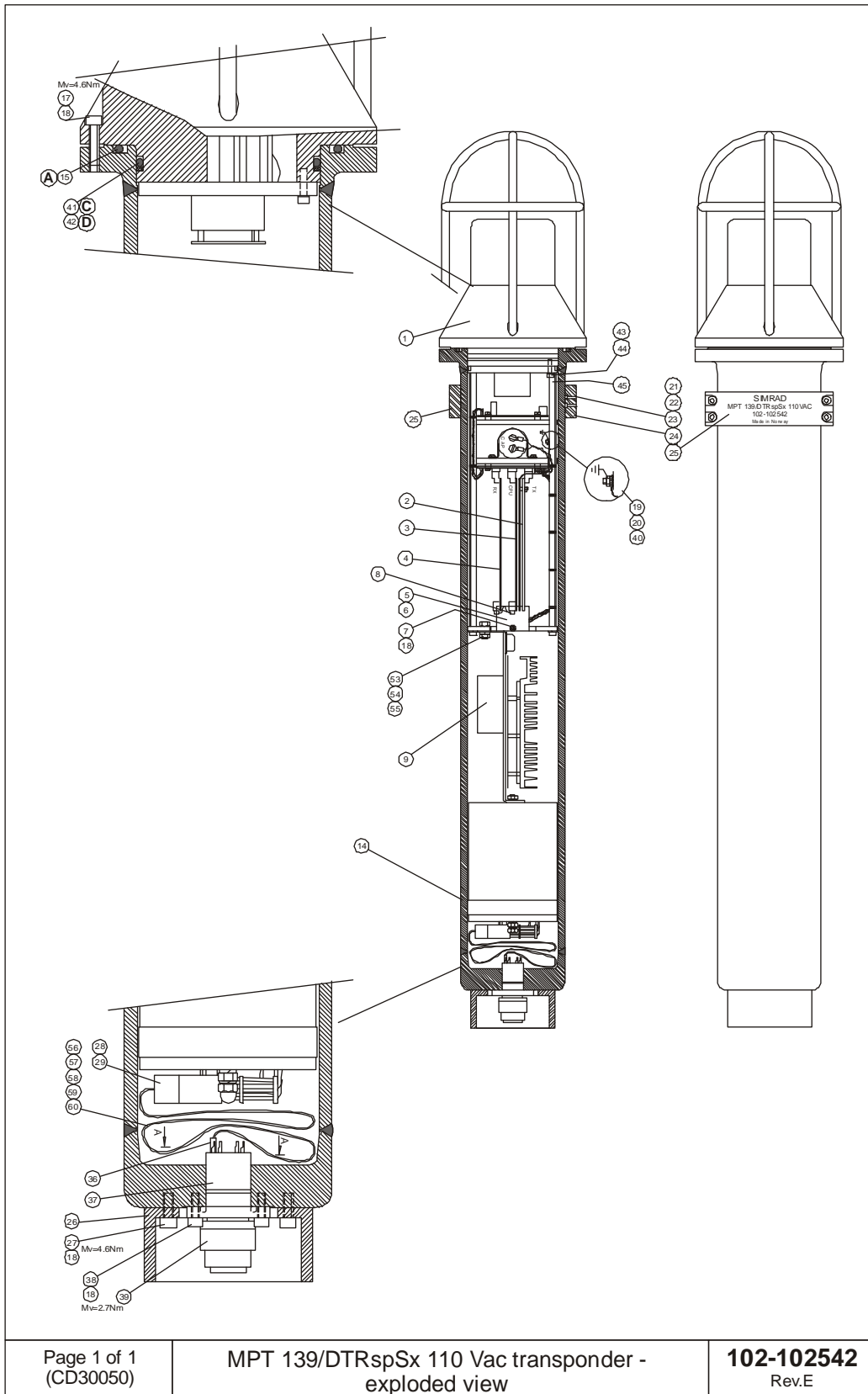

SAFETY INFORMATION FOR TRANSPONDER AND TRANSPONDER BATTERY

The purpose of this chapter is to provide safety information for the Kongsberg Maritime transponders with lithium battery and separate Kongsberg Maritime transponder lithium batteries. It also includes emergency procedures.

Warning

This document must be read before handling transponders with lithium battery and separate transponder lithium batteries.

Topics

- *Identification of the products and company on page 138*
- *Composition and information on ingredients on page 140*
- *Hazards identification on page 141*
- *First-aid measures on page 142*
- *Fire-fighting measures on page 142*
- *Accidental release measures on page 143*
- *Handling and storage on page 143*
- *Exposure controls and personal protection on page 147*
- *Physical and chemical properties on page 147*
- *Stability and reactivity on page 147*
- *Toxicological information on page 148*
- *Ecological information on page 148*
- *Disposal considerations on page 148*
- *Transport information on page 149*
- *Regulatory information on page 149*
- *Other information on page 149*

Identification of the products and company

Product name

All Kongsberg Maritime transponders with a lithium battery, and separate Kongsberg Maritime transponder lithium batteries.

Range of battery products

PART NUMBER	BATTERY TYPE
290-089501	L10/36 (15/20)
290-101665	L10/36 (18/30)
290-103053	L10/36 (15/40)
290-089505	L10/36 (36/60)
290-102726	L10/40 (3/11)
290-210845	L10/40 (3/11)
290-089010	L10/21 (6/12)
290-082380	L10/21 (6/48)
290-089592	L10/50 (12/42)
290-222071	L10/50 (27/28)
290-083530	L50/10/24
290-219492	L24 (98)
290-062447	L50
290-080718	L80
325902	L14.4 (48)
319554	D48-Li

Company address

Kongsberg Maritime AS

P.O.Box 111

N-3190 Horten

Norway

Emergency contact

Duty phone 24 hour: +47 992 03 808

Composition and information on ingredients

Battery chemistry

A transponder lithium battery consists of **Lithium Metal** cells with chemistry:

Lithium Thionyl Chloride - Li/SOCl₂

- Negative electrode: Lithium metal (Li)
- Positive electrode: Carbon
- Electrolyte: Solution of lithium tetrachloroaluminate (LiAlCl₄) in thionyl chloride

Battery weight and lithium content

PART NUMBER	BATTERY TYPE	BATTERY WEIGHT (kg)	LITHIUM CONTENT (g)
290-089501	L10/36 (15/20)	4,3	175
290-101665	L10/36 (18/30)	5,6	240
290-103053	L10/36 (15/40)	6,6	235
290-089505	L10/36 (36/60)	11,7	480
290-102726	L10/40 (3/11)	1,7	70
290-210845	L10/40 (3/11)	1,7	70
290-089010	L10/21 (6/12)	2,2	90
290-082380	L10/21 (6/48)	6,7	270
290-089592	L10/50 (12/42)	6,5	228
290-222071	L10/50 (27/28)	6,6	247
290-083530	L50/10/24	10	438
290-219492	L24 (98)	11	490
290-062447	L50	4,3	175
290-080718	L80	6,8	280
325902	L14.4 (48)	5,9	183
319554	D48-Li	5,9	183

Battery cell manufacturers/types

A transponder lithium battery consists of cells from one or two of the following manufacturers and types:

- Tadiran TL-2300
- Sonnenschein SL-78
- Saft LS 33600
- Saft LSH 20
- Sonnenschein SL-760

Battery design

A transponder lithium battery consists of several battery cells that are electrical connected, both in serial and parallel.

There are transponder batteries with different number of cells, voltages and capacity.

All transponder batteries include protection against short-circuits (re-settable fuses) and reverse current (diodes).

Hazards identification

Short-circuits, overheating, mechanical damage and exposure to water can start chemical reactions and high currents inside the transponder lithium battery. This can generate noxious gases and/or danger of explosions. The chemical reactions will continue without additional supply of oxygen, as the battery cells contain the necessary ingredients for maintaining the chemical reactions.

During operation, the battery is placed inside the transponder. Water ingress into the transponder can cause dangerous situations.

Danger of explosions

- If the cells that form the battery exceed the critical temperature of 180° C, they may explode.
- **External fire** - The temperature can reach the critical point of 180° C.
- **Water ingress** - The battery temperature will increase, caused by the high internal currents. The temperature can reach the critical point of 180° C.
- **Water ingress** - Electrolysis gives hydrogen. Together with oxygen, hydrogen can create oxyhydrogen gas inside the transponder (depends on the concentration). This gas is very inflammable/explosive.
- **Water ingress** - Chemical reactions in the battery will cause a pressure build-up inside the transponder. The transponder can explode if the inside pressure is high enough.
- If the transponder explodes, either the transducer or the bottom end cap will blow out, or the transponder becomes fragmented. This can cause serious damages on personnel and/or equipment.
- Some transponders have a relief valve that will prevent over-pressure. Noxious gases will then leak out of the transponder until the chemical reactions have stopped.

Note

The relief valve can be plugged, caused by products from the chemical reactions during an emergency as described above.

Noxious gases

- Thionyl chloride (SOCl₂)
- Sulphur dioxide (SO₂)
- Hydrogen chloride (HCl)
- Chlorine (Cl₂)

First-aid measures

All personnel that have been exposed to the noxious gases should immediately be seen by a doctor.

Inhalation:	Remove from exposure, rest and keep warm.
Skin contact:	Wash off skin thoroughly with water. Remove contaminated clothing and wash it before reuse.
Eye contact:	Irrigate thoroughly with water for at least 15 minutes.
Ingestion:	Wash out mouth thoroughly with water and give plenty of water to drink.

Fire-fighting measures

- **Cool down the battery with copious amounts of cold water.**
 - Transponder with lithium battery:
 - * Immerse the transponder in the sea for 24 hours or permanent.
 - * If this method is impossible, the transponder can be cooled down by use of a fire hose.
 - Separate transponder lithium battery:
 - * Immerse the battery in the sea for 24 hours or permanent.
 - * If this method is impossible, the battery can be cooled down by use of a fire hose.

Cooling down the battery with copious amount of cold water is the only way to reduce/stop the internal chemical reactions, or to limit the fire/explosions to as few battery cells as possible. The chemical reactions/fire will continue without additional supply of oxygen, so extinguisher like Lith-X will not work properly.

Applying water directly onto a battery may develop hydrogen gas, due to the possible electrolysis if the battery terminals are exposed to water. Mixed with air, this gas is very inflammable/explosive. However, if the water cooling takes place out on deck, or in a storeroom with good ventilation, there will never be enough hydrogen gas to exceed the lower explosive limit of hydrogen in air (ca 4%).

- **Remove transponders with lithium battery and separate transponder lithium batteries in case of an external fire if possible.**

Accidental release measures

Refer to Handling and Storage below

Handling and storage

All personnel that handle transponders must know the transponder's status:

”Functioning“- ’Failing“- ”Unknown”

A Transponder with unknown status, **must be handled** as a transponder that is failing.

Recovering a “functioning” transponder

- All transponders recovered from the sea, should be placed in a safe place out on deck and controlled for minimum 2 hours:
 - Look for outer damages that could involve a water leakage.
 - The transponder housing temperature must be checked to verify a possible temperature increase in the lithium battery.
- If everything is OK refer to Kongsberg Maritime transponder instruction manuals for normal procedures.

Recovering a "failing" transponder

- Handle as possible water ingress.
- Evacuate all unnecessary people.
- Recover the transponder with great precaution. Use a crane.
- No people should be near the transponder when it is lifted up on deck.
- Place the transponder in a safe place out on deck, shielded from people and vital equipment.
- Fasten the transponder in a crane, ready to lower it into the sea again.
- Control the transponder for minimum 2 hours:
 - Look for outer damages that could involve a water leakage.
 - The transponder housing temperature must be checked to verify a possible temperature increase in the lithium battery.

Failing and normal temperature:

- Take out the battery - see *Opening a transponder with defect/possible defect battery*.

Failing and increasing temperature:

- See Handling a heated or self-heated transponder.

Handling a heated or self-heated transponder

- Evacuate all unnecessary people.
- Fasten the transponder to a rope and immerse it in the sea for 24 hours or permanent.
 - If this method is impossible, the transponder can be cooled down with copious amount of cold water.
 - Use a fire hose.
- Recover the transponder and control the temperature.
- Repeat this until the temperature is low and stable.
- The transponder can now be opened - see *Opening a transponder with defect/possible defect battery*.

Handling a transponder if relief valve opens

- Evacuate all unnecessary people.
- Use necessary protection equipment.
- Fasten the transponder to a rope and immerse it in the sea for 24 hours or permanent.
 - If this method is impossible, the transponder can be cooled down with copious amount of cold water.
 - Use a fire hose.
- Repeat this until no gases come out the check valve and the temperature is low and stable.
- The transponder can now be opened - see *Opening a transponder with defect/possible defect battery*.
- Wash out chemical reaction products with water.

Opening a transponder with defect/possible defect battery

- The transponder is reported failing. There could have been water ingress in the transponder.
- Open the transponder in a safe place out on deck, shielded from people and vital equipment.
- Use necessary protection equipment.
- Do not stand in front of transducer or bottom end cap, when opening the transponder.
- If there has been water ingress, and the battery is still warm:
 - Disconnect the battery from the transponder electronics, and then - see *Handling heated or warm separate battery*.
- Wash out chemical reaction products with water.

Opening a "functioning" transponder

- The transponder is reported functioning.
- Open the transponder in a safe place out on deck, shielded from people and vital equipment.

Caution

Do not stand in front of transducer or bottom end cap, when opening the transponder.

Handling heated or warm separate battery

- Evacuate all unnecessary people.
- Fasten the battery to a rope and immerse it in the sea for 24 hours or permanent.
 - If this method is impossible, the battery can be cooled down with copious amount of cold water.
 - Use a fire hose.
- Wash out chemical reaction products with water.

Handling transponders and separate transponder batteries in case of an external fire

- Remove transponders with lithium battery and separate transponder lithium batteries in case of an external fire if possible
- Cool down transponders and separate transponder batteries with copious amounts of cold water - see **Chapter, Fire-fighting measures** on page 142.

Storage

Caution

A transponder that is failing must be stored in a safe place out on deck, shielded from people and vital equipment.

Caution

For a transponder that is functioning, the battery must be removed from the transponder when stored.

A transponder that is functioning, and separate batteries can be stored indoors. The battery must be removed from the transponder when stored indoors.

- Storage temperature:
 - Recommended storage temperature lies between 0° C and +25° C (max +50° C, min -55° C).
- Storage relative air humidity:
 - Recommended relative air humidity is 40 to 70%.
- A transponder/separate battery must not be stored directly in the sunlight.

- A battery must not be exposed to water.
 - Storeroom:
 - A solid room with study racks for transponders/separate batteries.
 - A room where no people are staying, or no vital equipment is placed.
 - Good ventilation.
 - Clearly identified.
 - Easy to remove transponders and batteries in case of an external fire.
-

Caution

The storeroom must have a sprinkler system or a fire station, with fire hose (water), must be placed outside the storeroom.

Exposure controls and personal protection

Fire/explosion:

- Use self contained breathing apparatus.

Relief valve opens and noxious gasses come out:

- Use a full face mask with minimum BE-filter, and protective equipment of rubber or plastic.

Opening transponder with defect/possible defect battery:

- Use a full face mask with minimum BE-filter, and protective equipment of rubber or plastic.

Opening a functioning transponder:

- Use protective goggles.

Physical and chemical properties

Not applicable unless individual components exposed.

Stability and reactivity

The products are stable under normal conditions - see *Chapter, Hazards identifications* on page 141.

Toxicological information

Signs and symptoms:

- None, unless battery ruptures. In the event of exposure to internal contents, corrosive fumes with pungent odour will be very irritating to skin, eyes and mucous membranes. Over-exposure can cause symptoms of non-fibrotic lung injury and membrane irritation.

Inhalation:	Lung irritant.
Skin contact:	Skin irritant.
Eye contact:	Eye irritant.
Ingestion:	Tissue damage to throat and gastro/respiratory tract if swallowed.
Medical conditions:	Eczema, skin allergies, lung injuries, asthma and other respiratory disorders may occur.

Ecological information

None known if used/disposed of correctly.

Disposal considerations

- A lithium thionyl chloride battery does not contain any heavy metals, and is therefore not regarded as special waste (contains only biodegradable parts).
- A used transponder lithium battery often contains a significant amount of residual energy. It is the danger of explosion that presents a problem when disposing a battery. Used batteries must therefore be handled with the same care as new ones.

Caution

For safe disposal, contact the nearest local company that has been approved to collect and dispose lithium batteries.

Transport information

Note

Kongsberg Maritime delivers the transponder unit and the battery as separate units, in separate transportation cages. Kongsberg Maritime recommends that the transponder and the battery always are kept in separate transportation cages during transportation. Original transponder/battery cages must be used.

All transponders with a lithium battery and separate transponder lithium batteries must be shipped in accordance with the prevailing national regulations.

Transponder with lithium battery:

UN no. 3091, Class 9 Miscellaneous
(Lithium batteries contained in equipment).

Separate transponder lithium battery:

UN no. 3090, Class 9 Miscellaneous (Lithium batteries)

Transport:

Aircraft:	IATA DGR
Sea Transport:	IMDG Code
Railway:	RID
Road transport:	ADR

- Aircraft - Transport of all transponders with new lithium battery and new separate transponder lithium batteries by air is only permitted onboard cargo aircraft. The goods must be clearly labelled:
CARGO AIRCRAFT ONLY
- Aircraft - Only new separate transponder lithium batteries can be transported by air.

Regulatory information

Not applicable.

Other information

The battery cell manufacturers' safety data sheets are available on the following Internet addressees:

- Saft: www.saftbatteries.com
- Tadiran / Sonnenschein: www.tadiranbatteries.de

DRAWING FILE

This chapter contains outline dimensions drawings. The illustrations are based on the original system drawings.

- All measurements are in mm.
- The illustrations are not in scale.
- The original drawings are available in electronic format (AutoCAD) upon request.

Drawings

The following outline dimensions drawings are implemented:

- **SPT 331 Aluminium**
 - SPT 331 on page 152
 - SPT 331/R on page 153
 - SPT 331/RspSx 110 Vac on page 154
- **SPT 331 Stainless steel**
 - SPT 331/St, SPT 331/R-St and SPT 331/I-St on page 155
 - SPT 331/II-St on page 156
 - SPT 331/RspSx 110 Vac-St on page 157
- **SPT 133 Stainless steel**
 - SPT 133 RspSx 110 Vac SU-St on page 158
 - SPT 133 RspSx 110 Vac SU-St, transducer unit on page 159
- **MPT 339 Aluminium**
 - MPT 339/DT on page 160
 - MPT 339/DTR on page 161
- **MPT 339 Stainless steel**
 - MPT 339/St on page 162
 - MPT 339/DTR-St on page 163
 - MPT 339/DTRspSx 110 Vac-St on page 164
- **MPT 331 Aluminium**
 - MPT 331/DTDuB on page 165
 - MPT 331/DTRDuB on page 166
- **MPT 331 Stainless steel**
 - MPT 331/DTDuB-St on page 167
 - MPT 331/DTRDuB-St on page 167

- **MPT 139 Stainless steel**
 - MPT 139/St and MPT 139/DT-St on page 168
 - MPT 139/DTR-St on page 169
 - MPT 139/DTRspSx 110 Vac-St on page 170
- **Power modules, wiring diagrams**
 - SPT / MPT 110 Vac on page 171
 - SPT 133/RspSx 110 Vac SU on page 172
- **Floating collars** on page 173
- **Guiding collars**
 - Aluminium transponder on page 174
 - Stainless Steel transponder on page 175

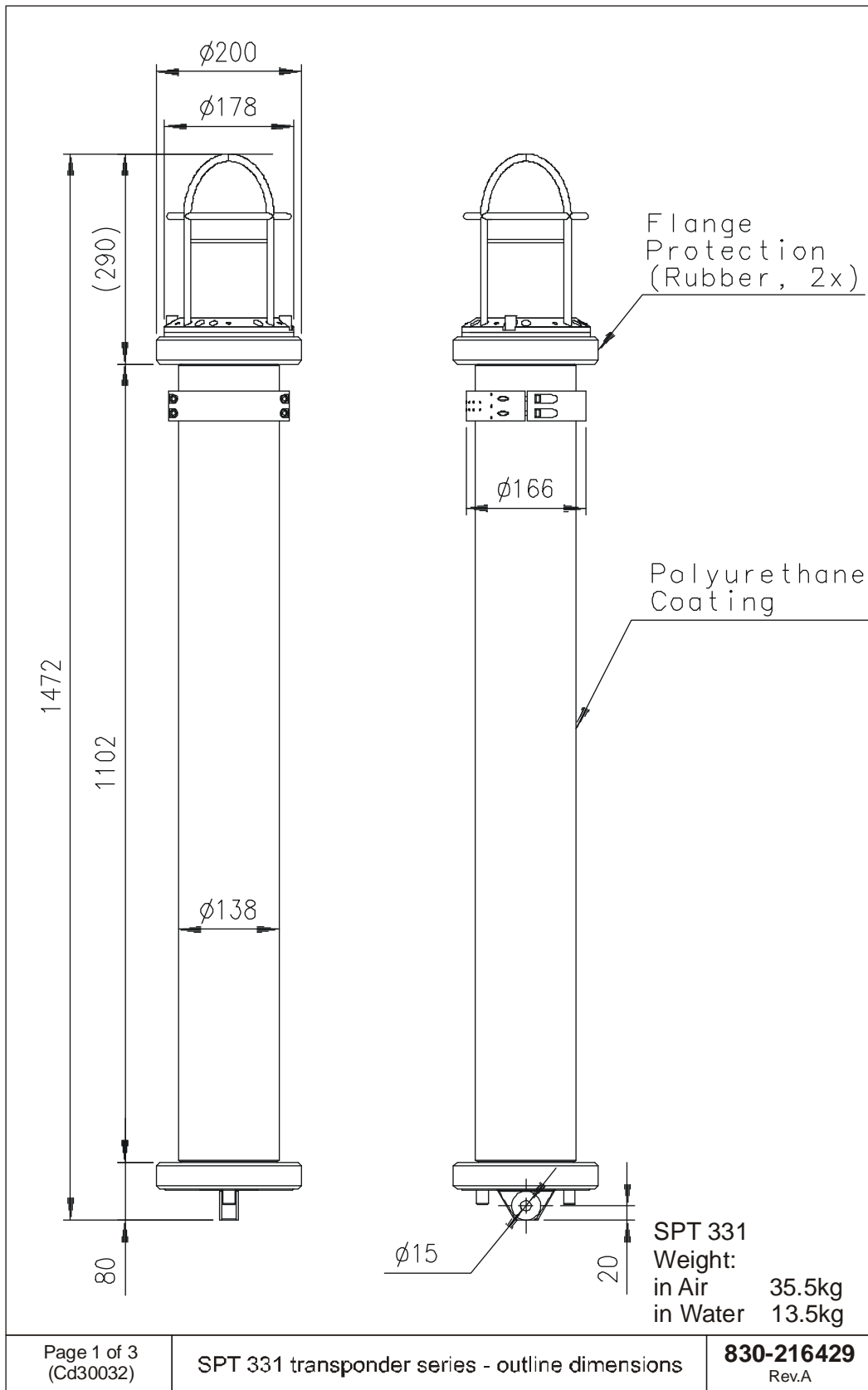

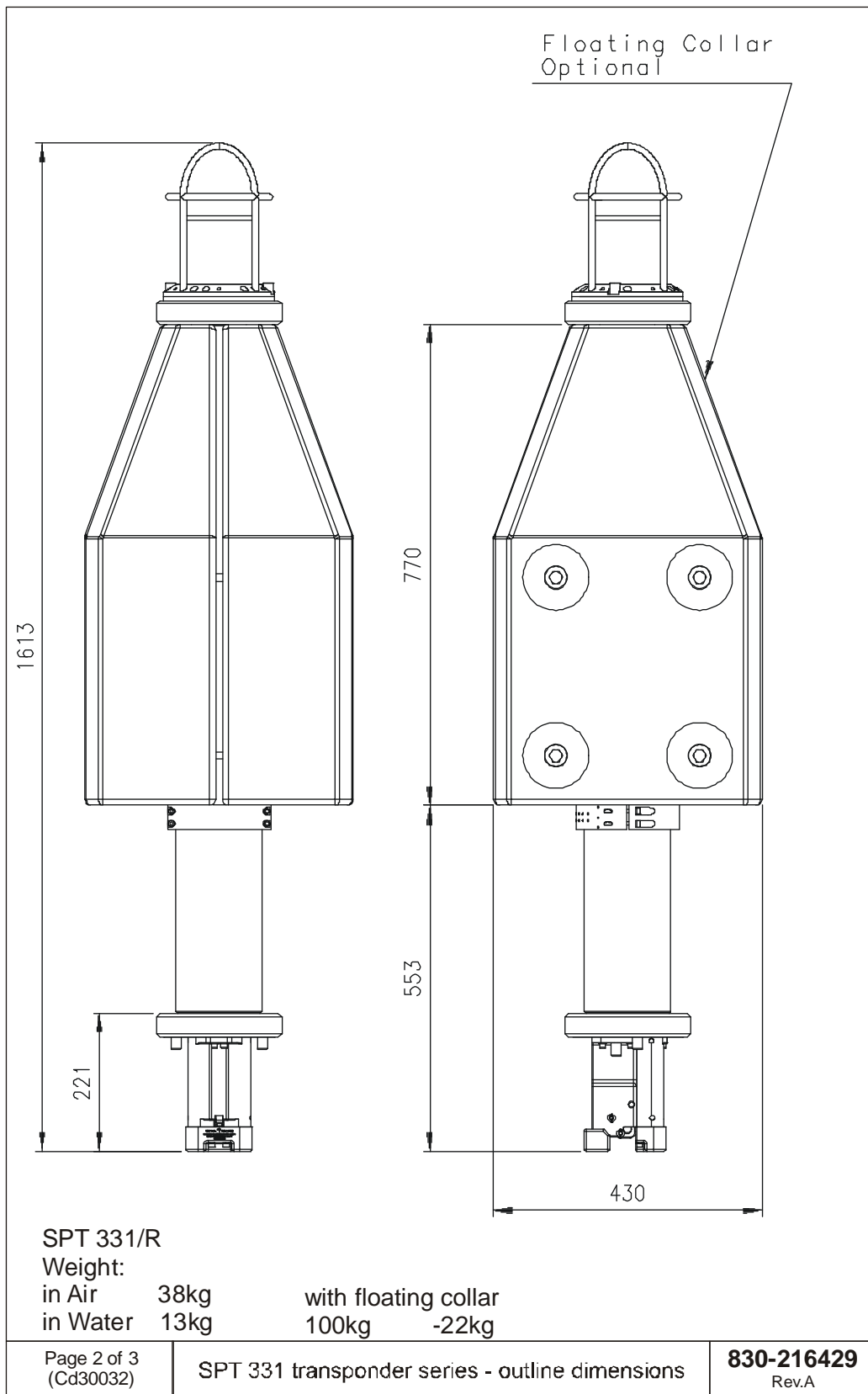

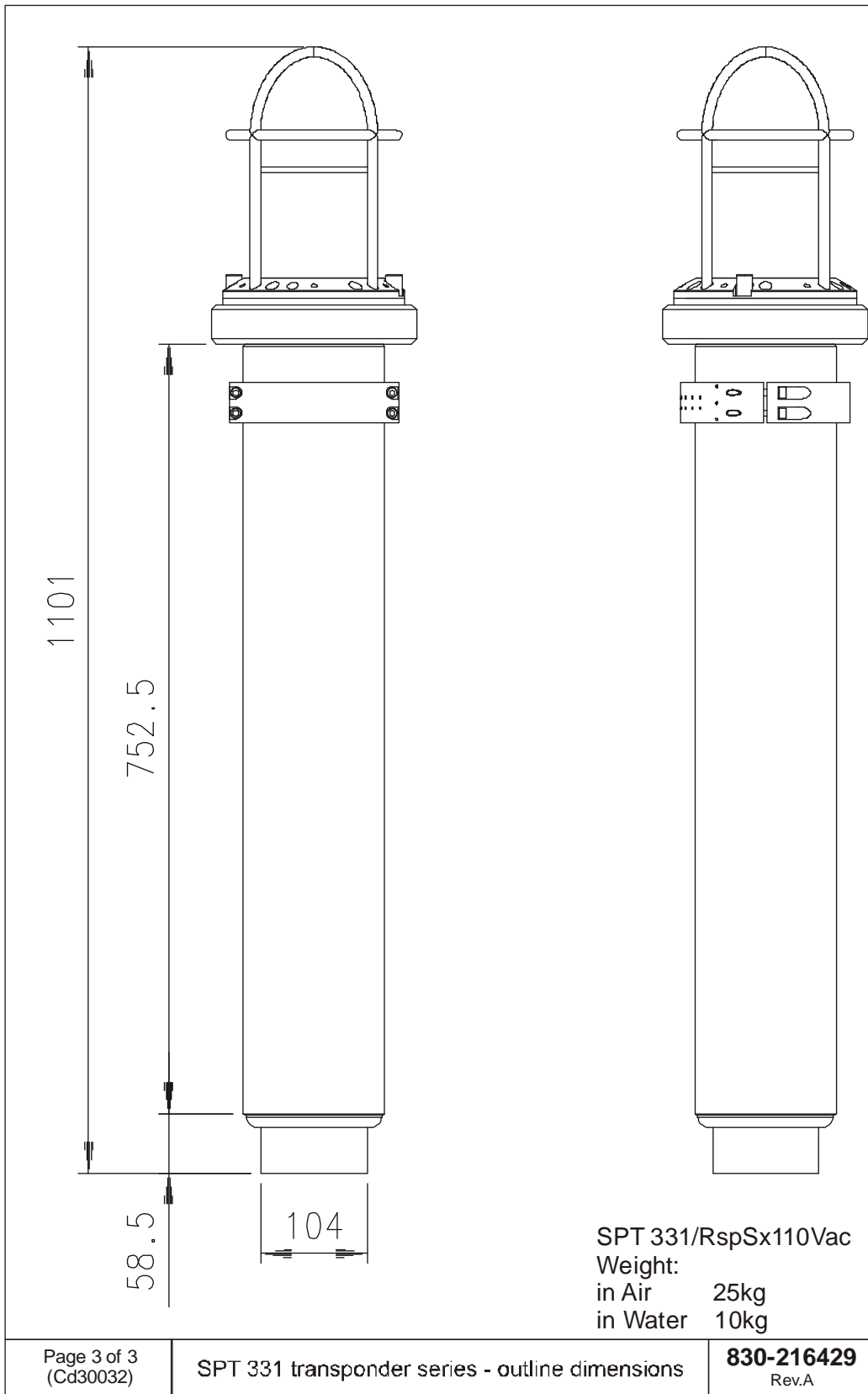

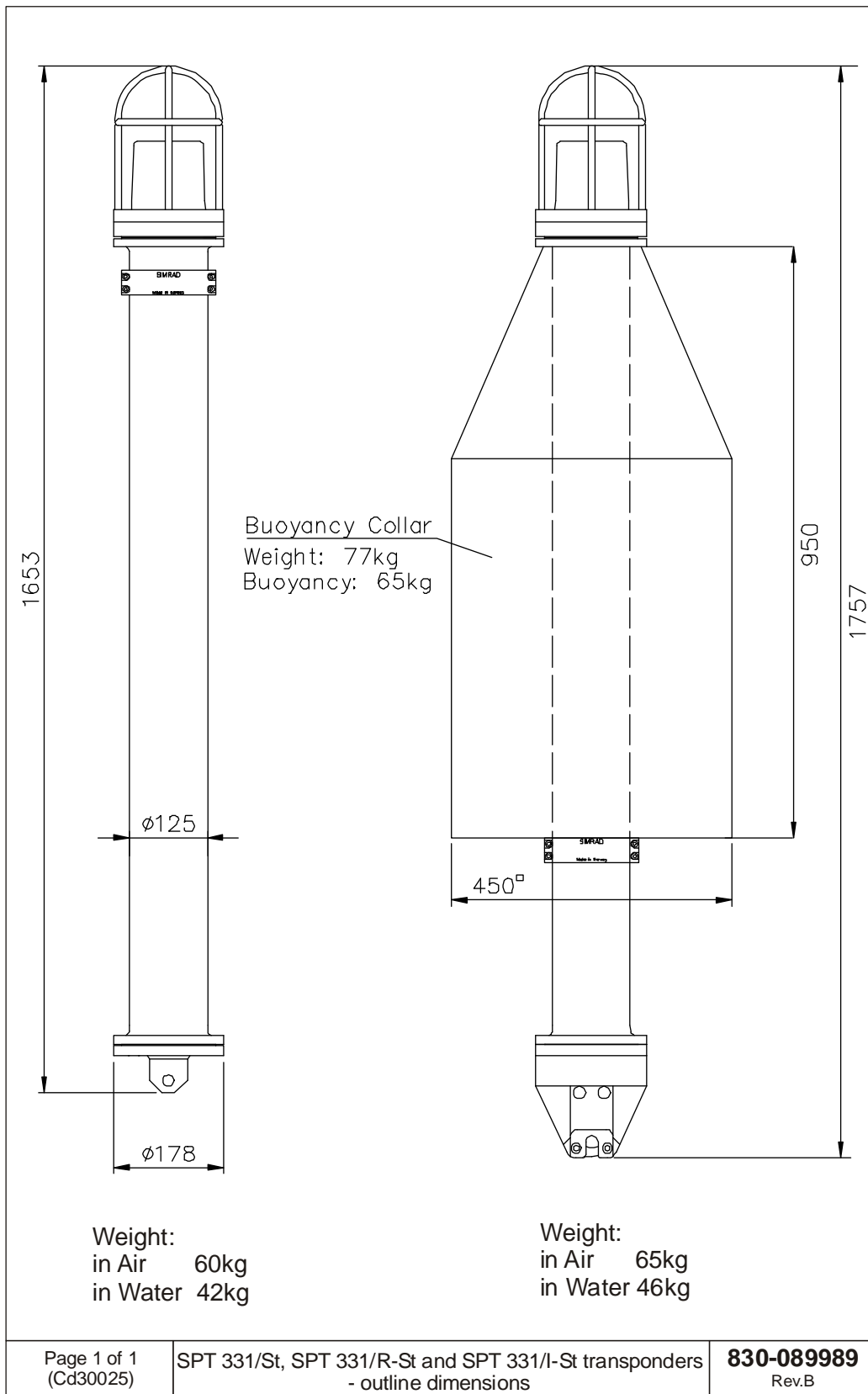

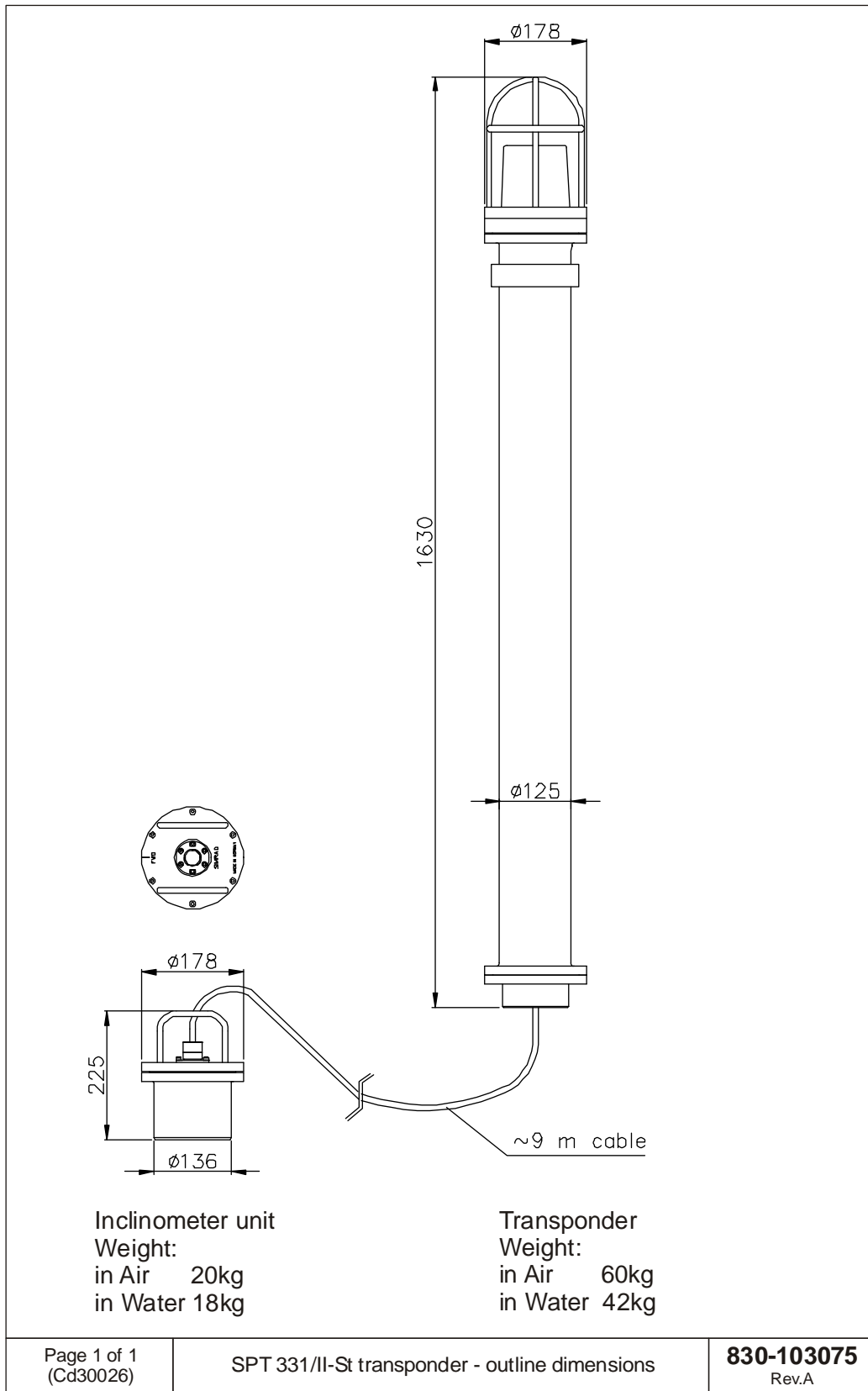

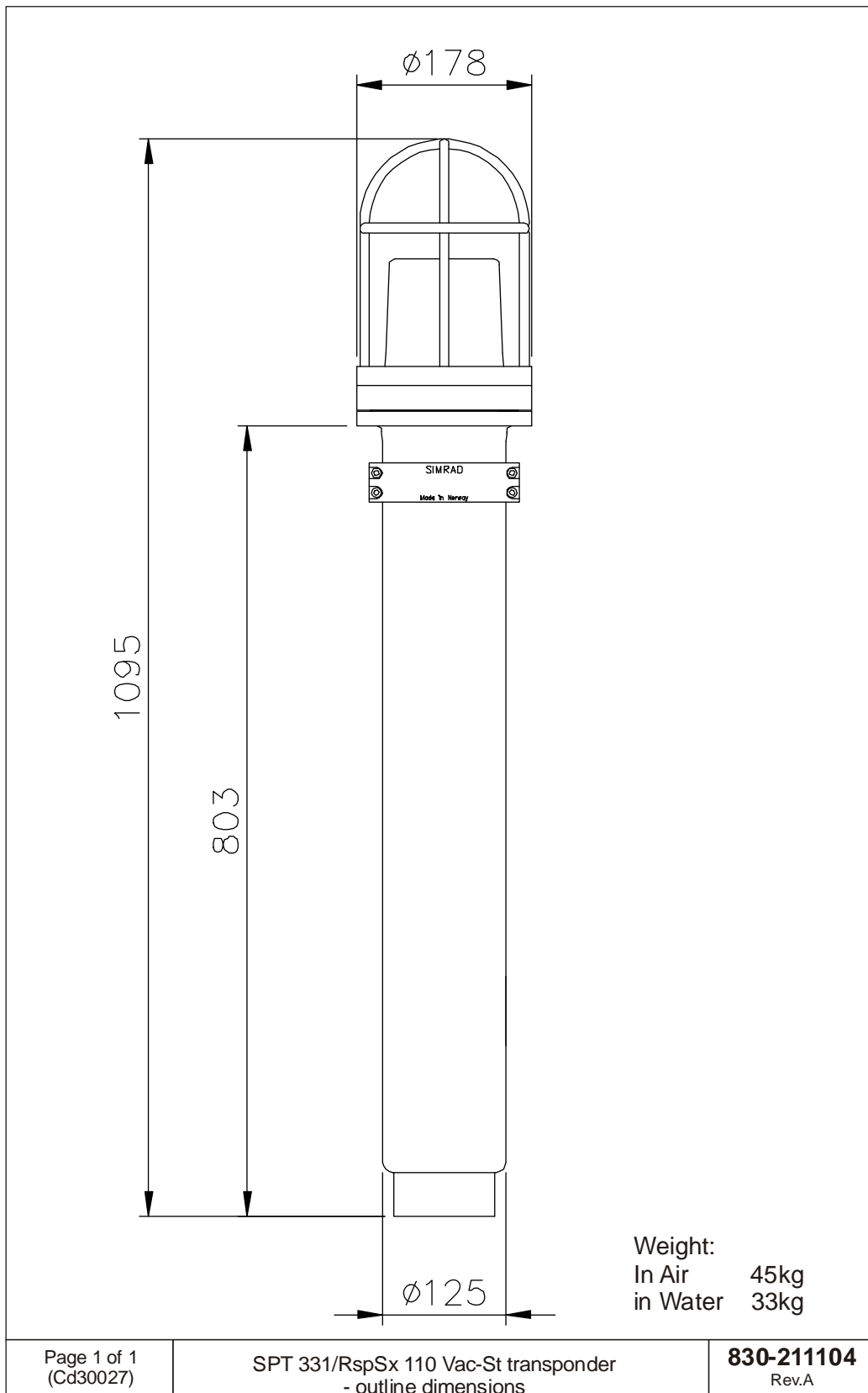

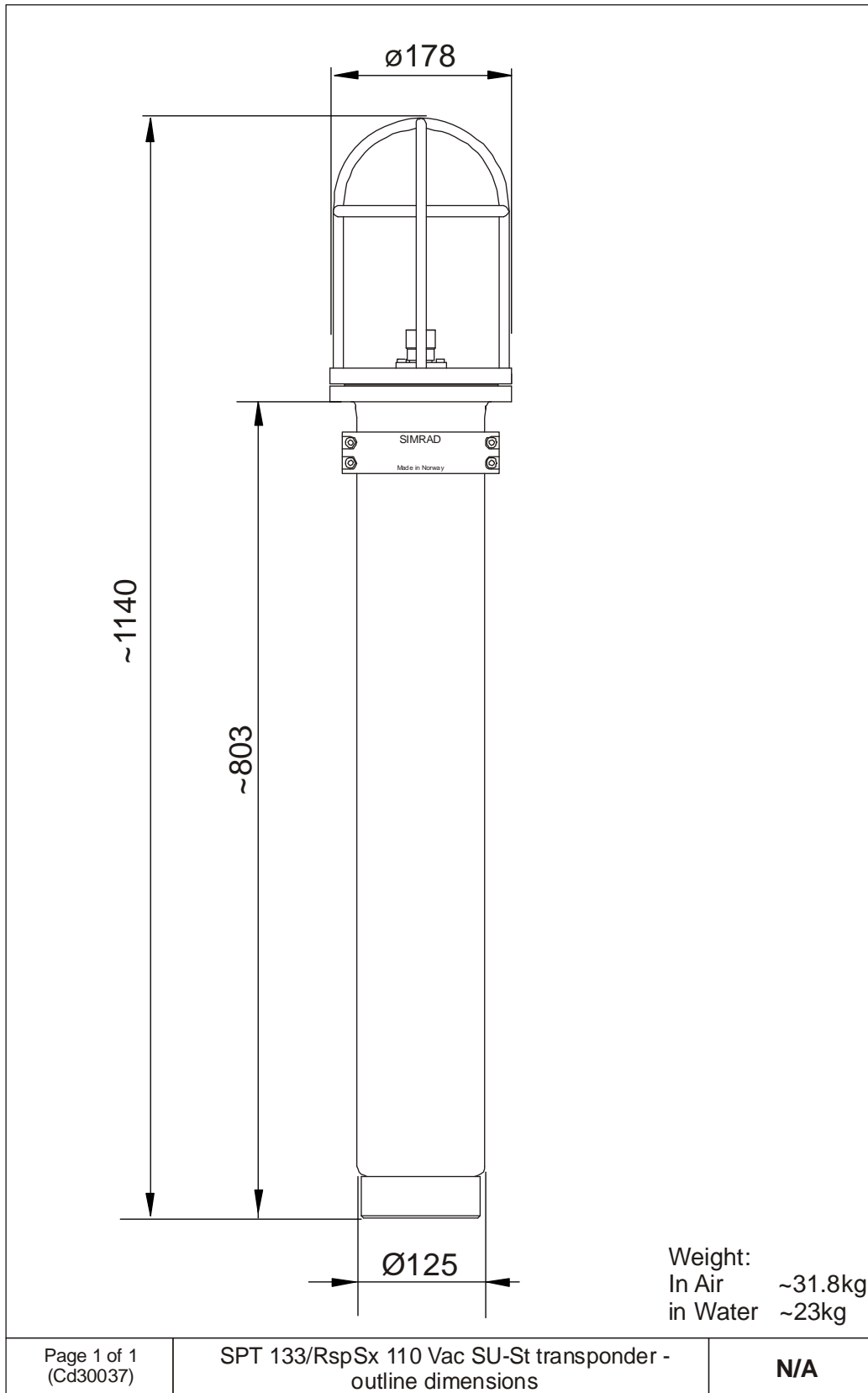

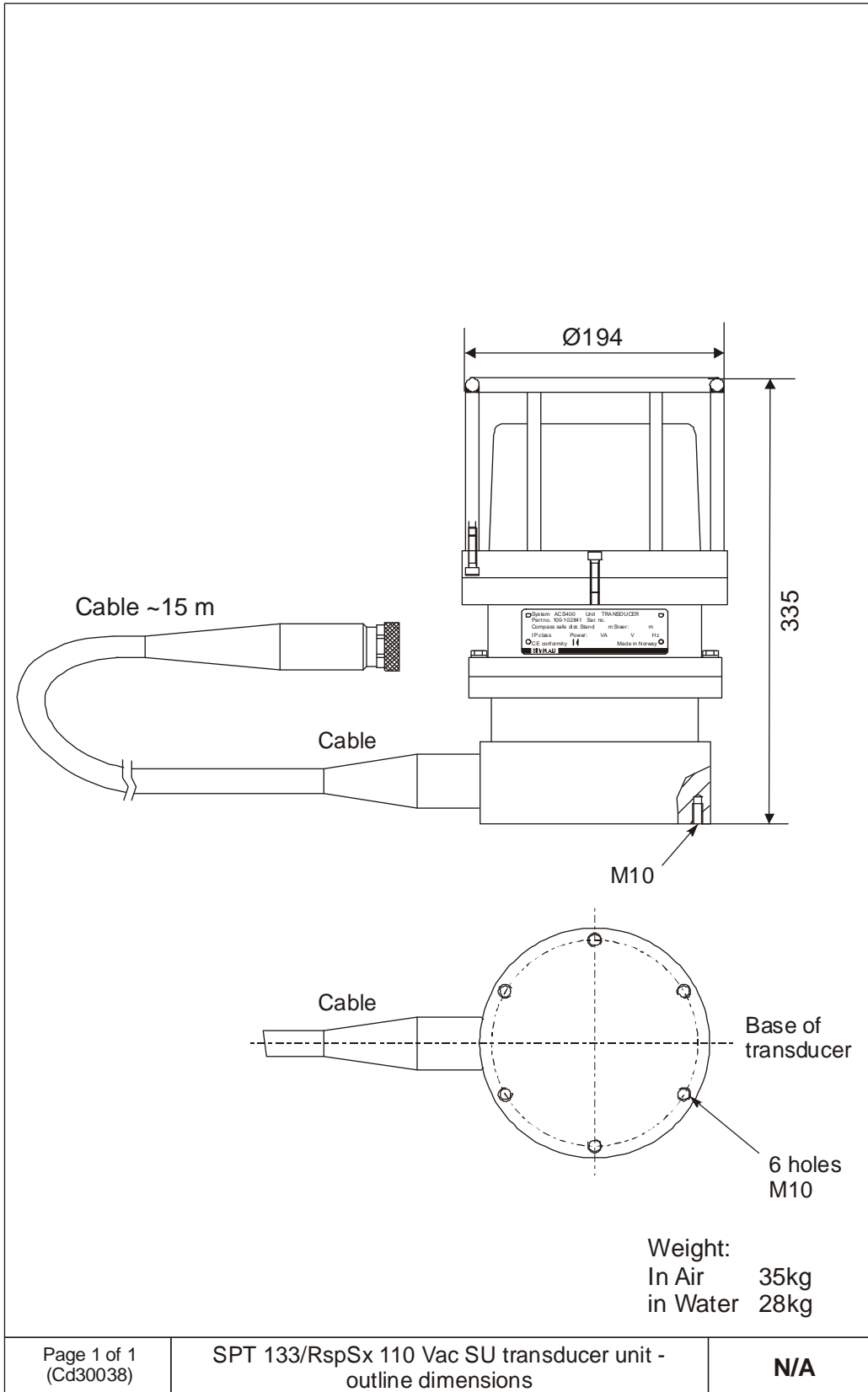

Page 1 of 1 (Cd30038)	SPT 133/RspSx 110 Vac SU transducer unit - outline dimensions	N/A
--------------------------	--	-----

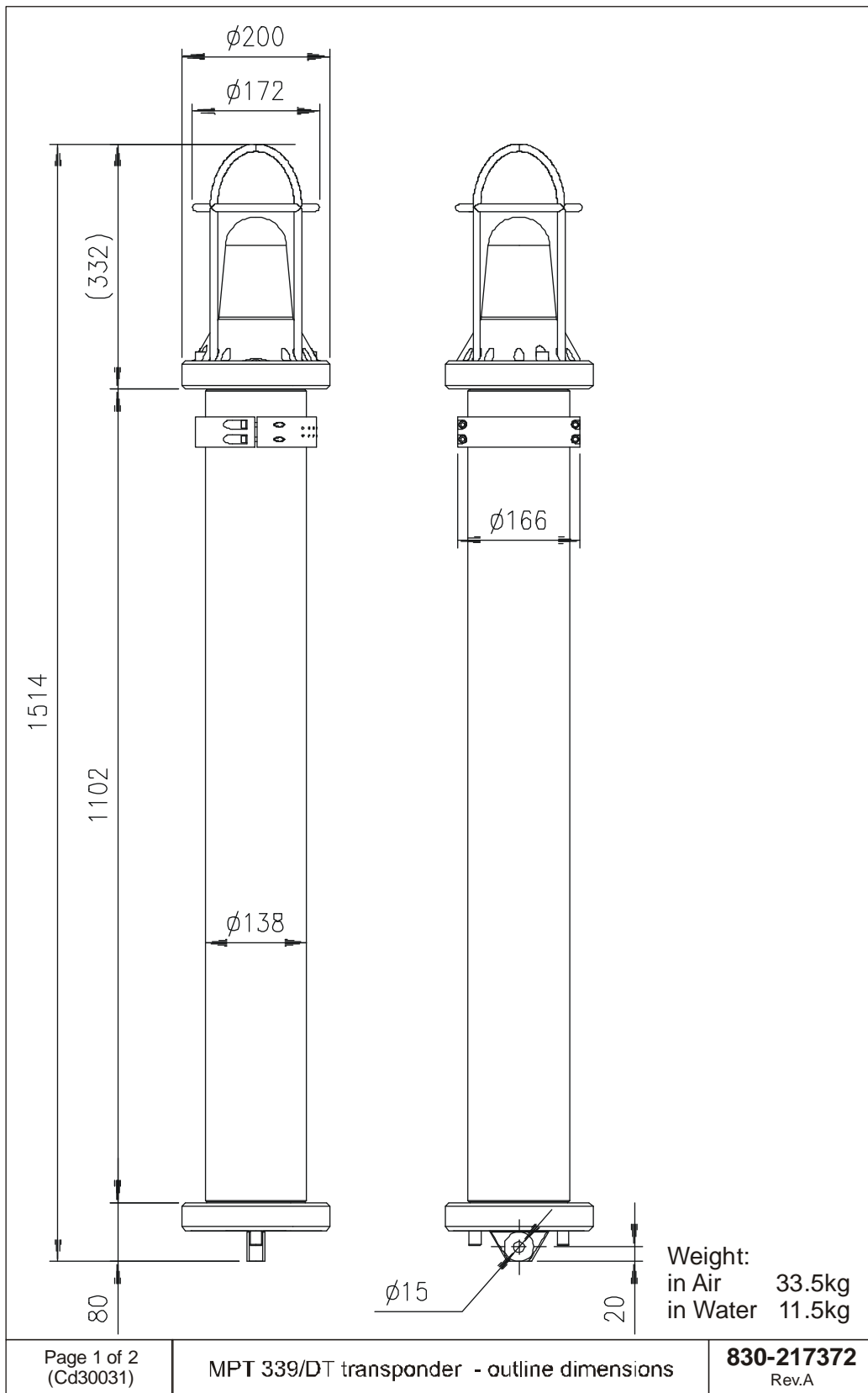

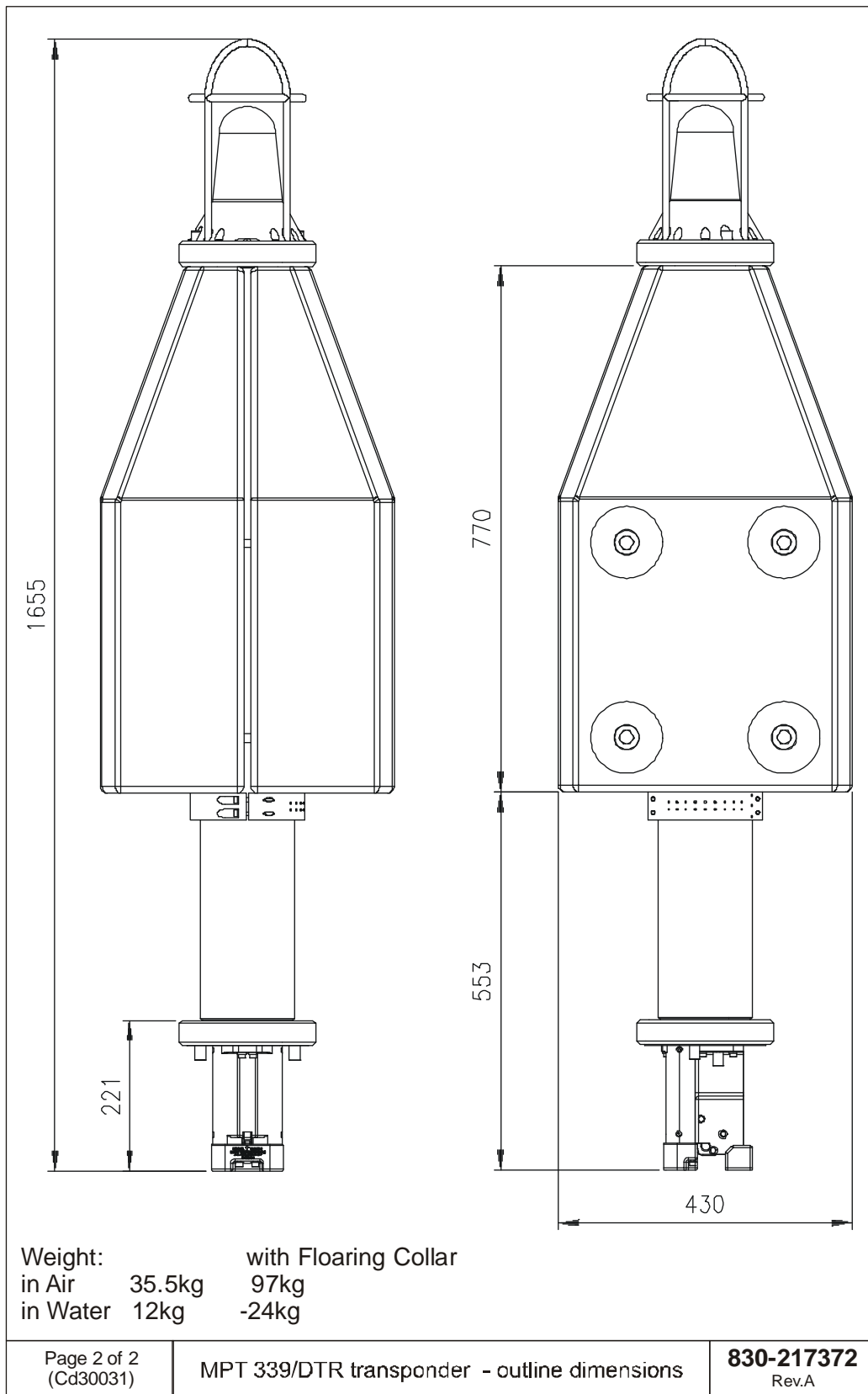

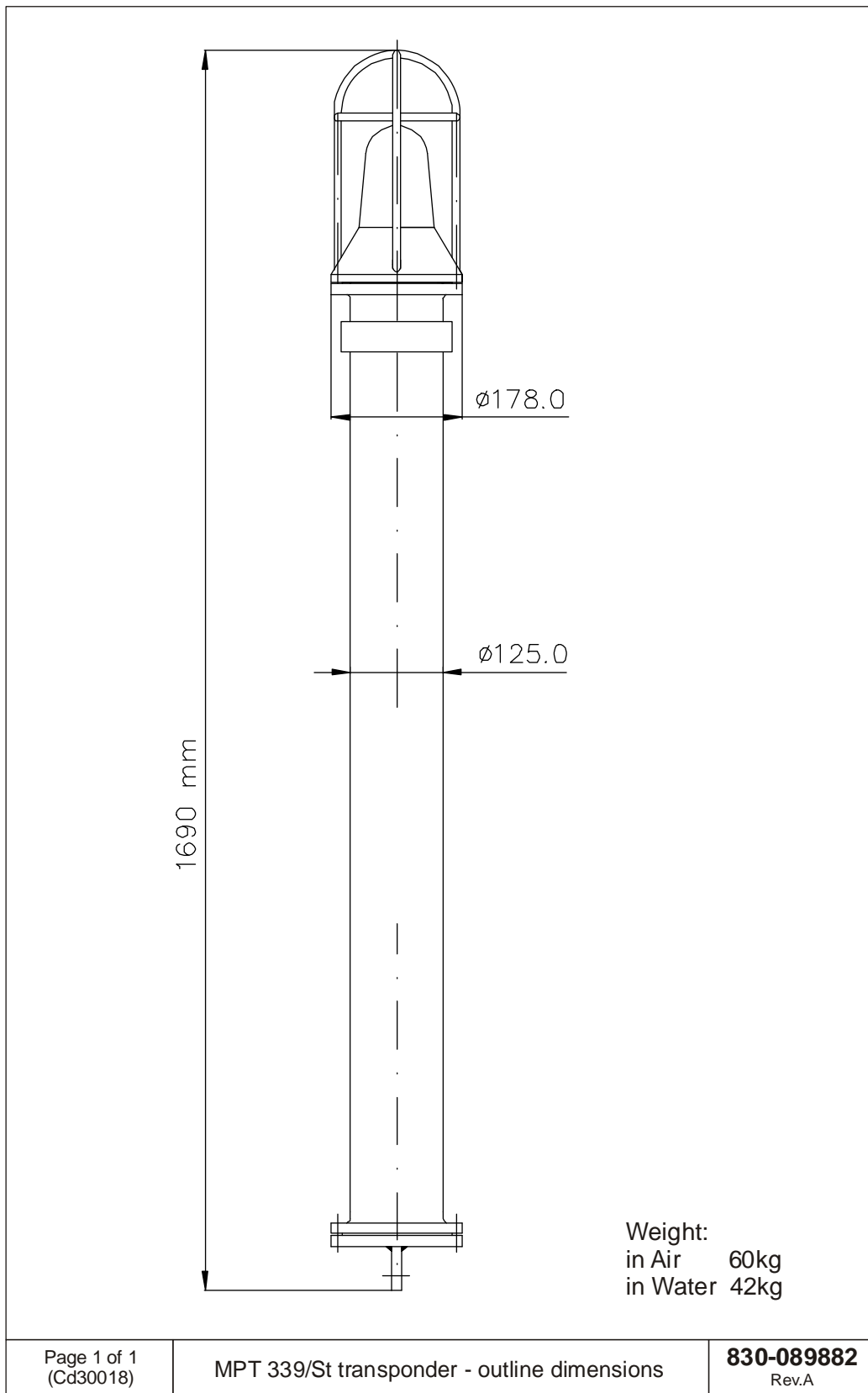

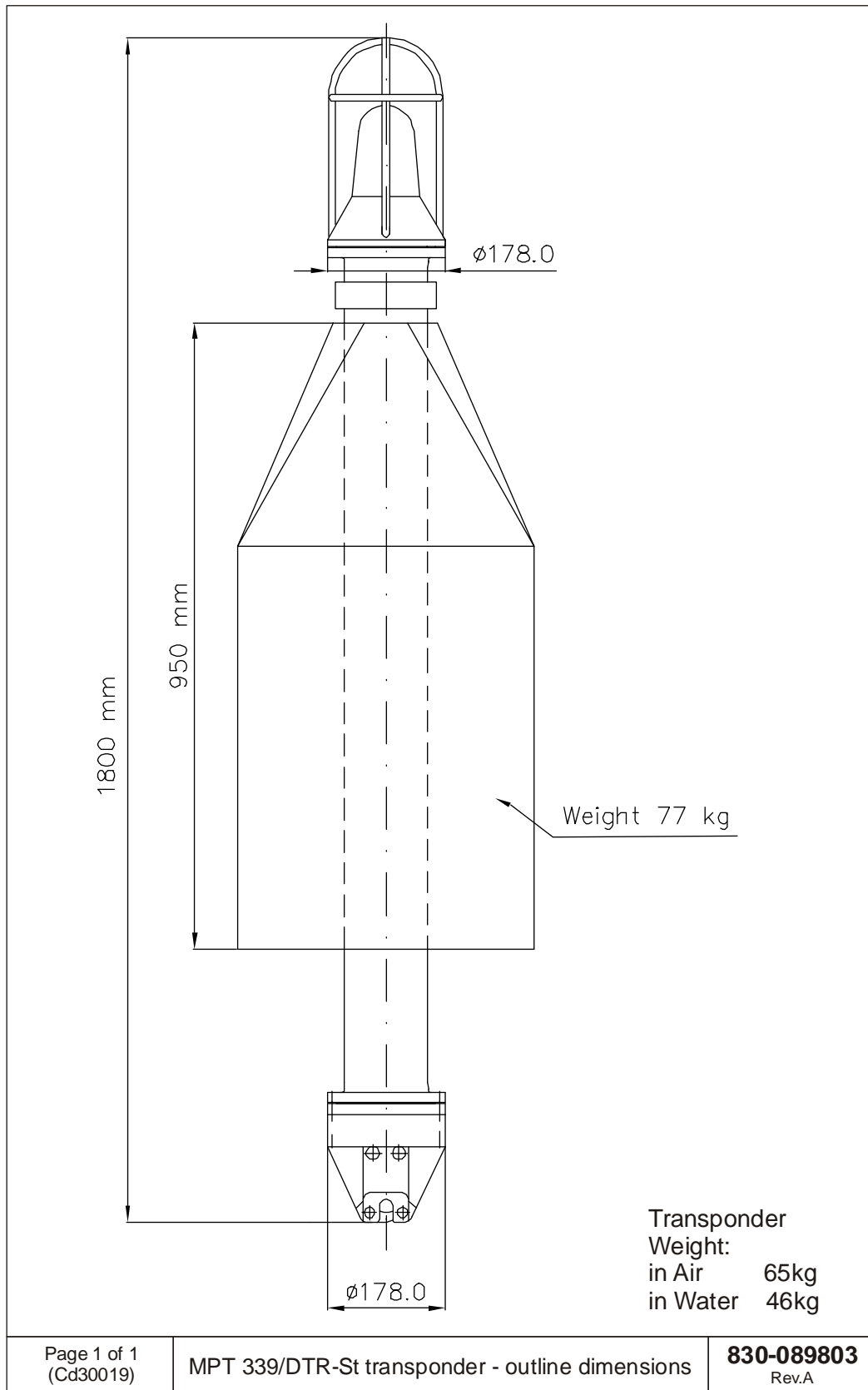

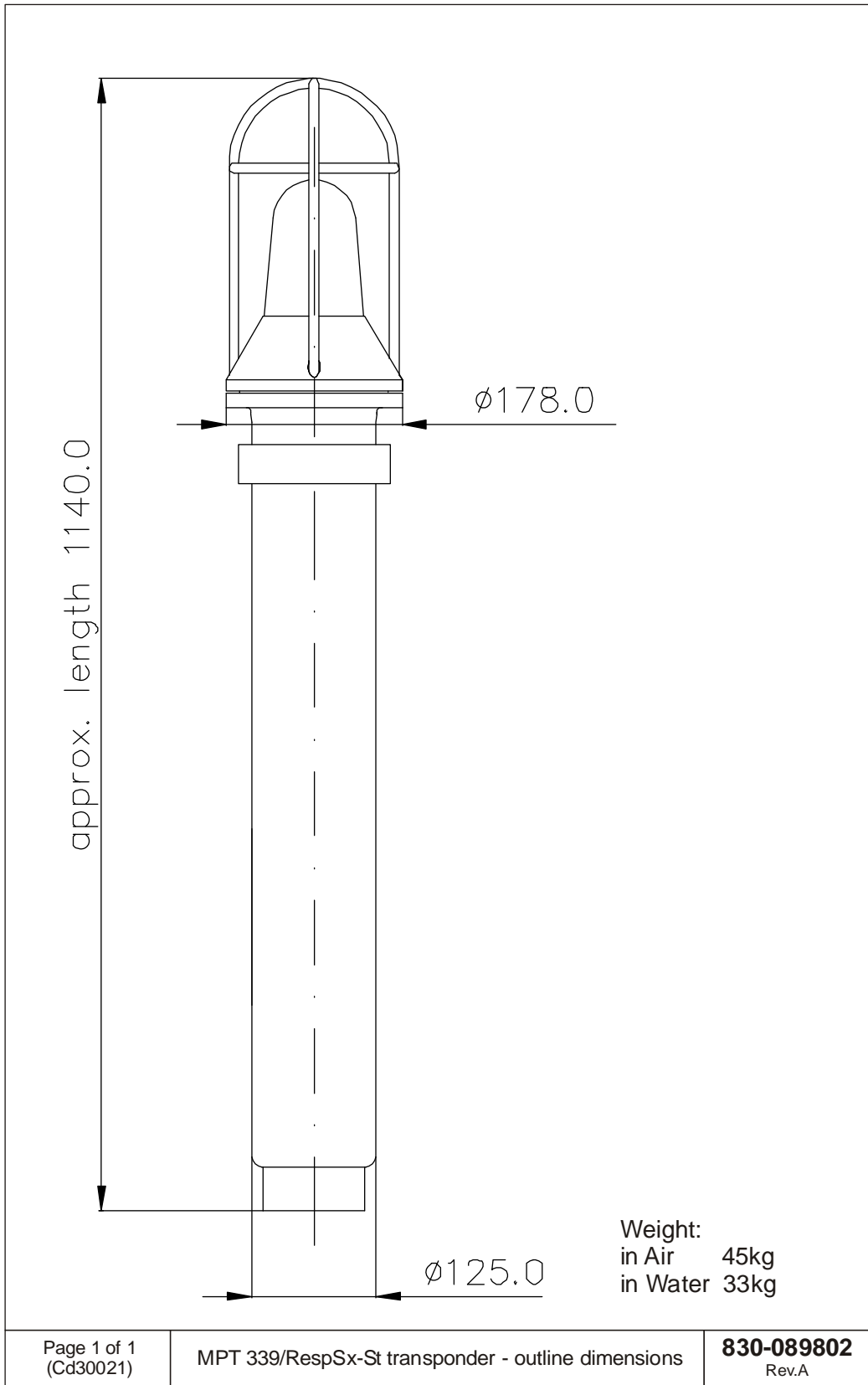

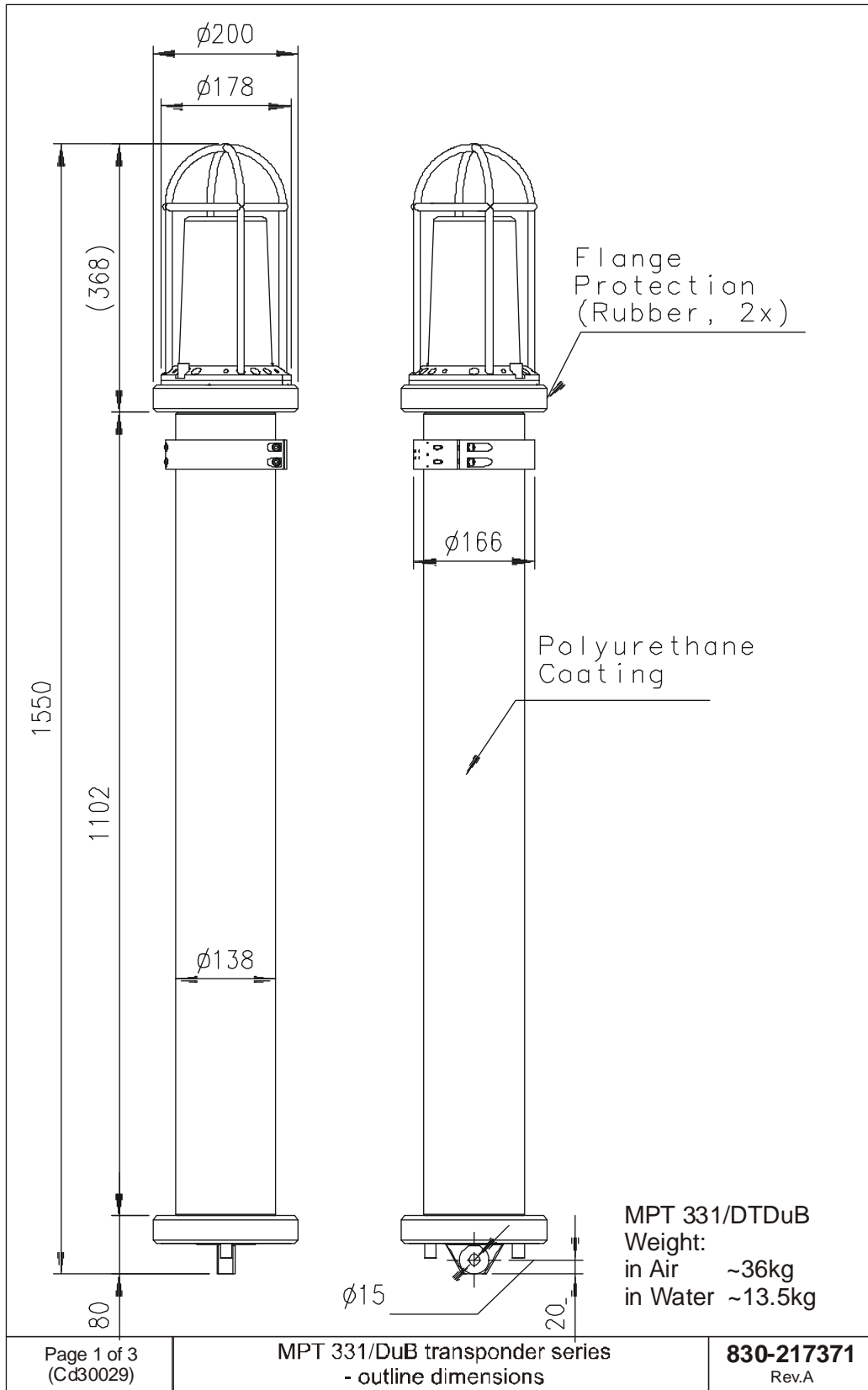

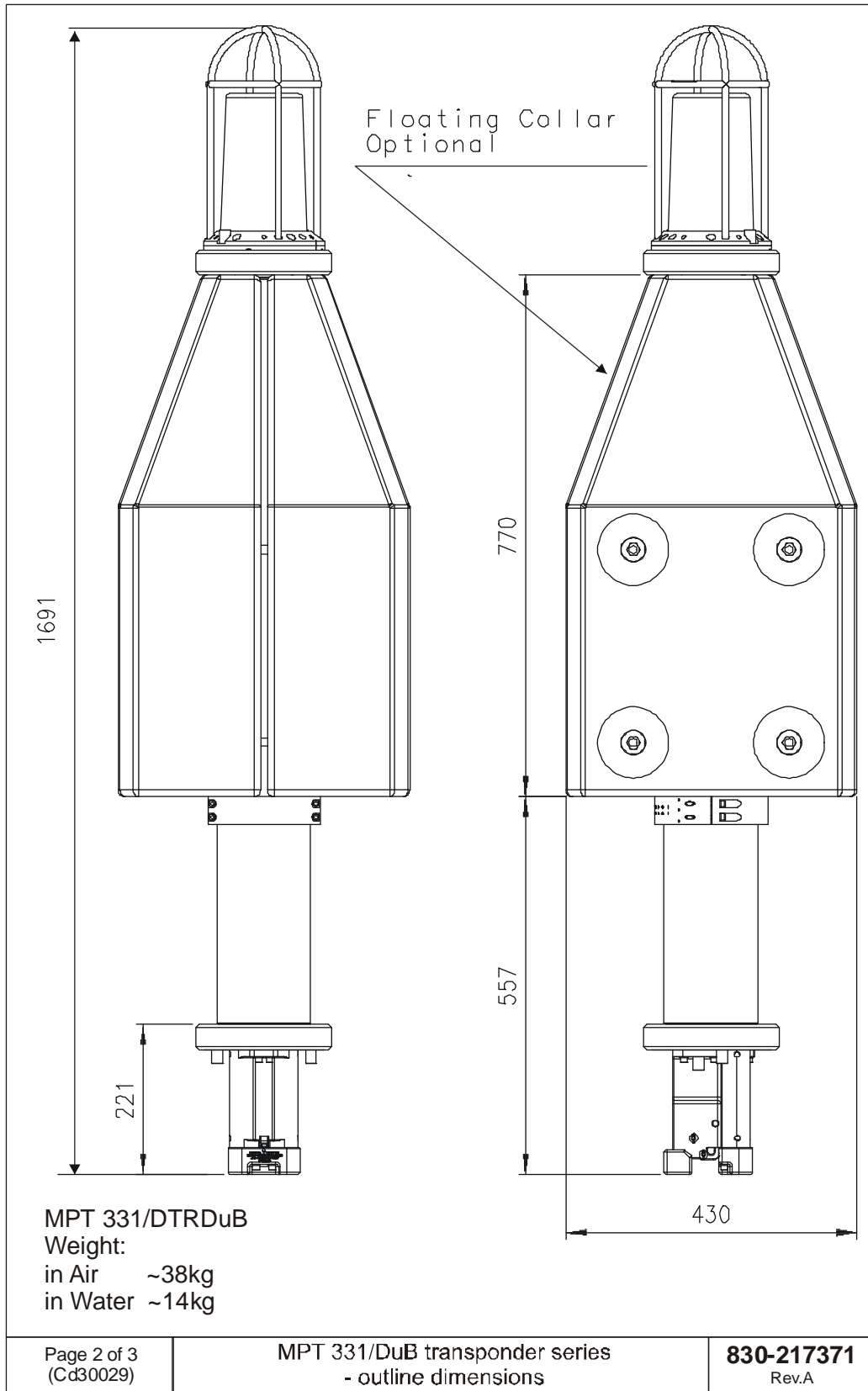

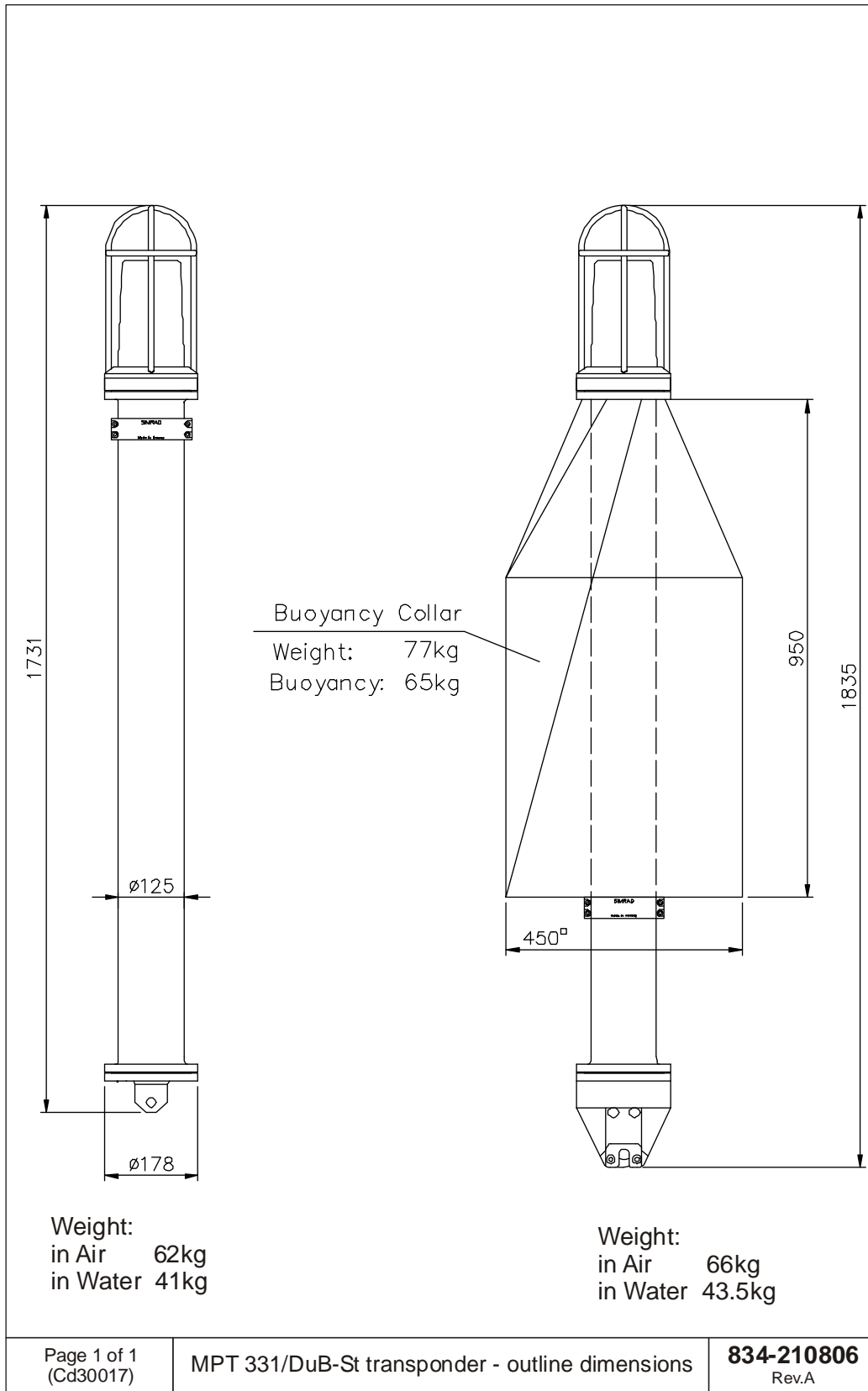

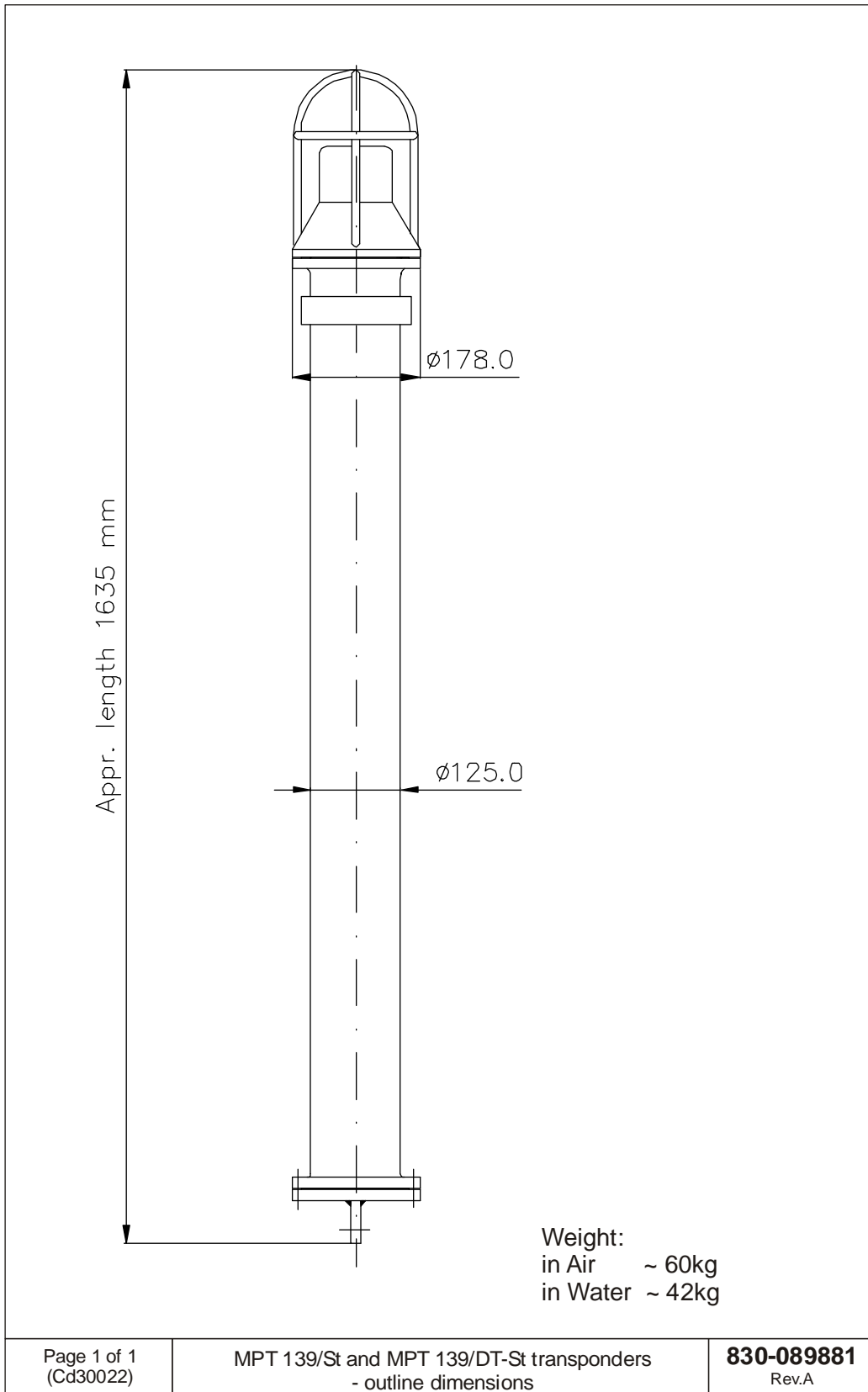

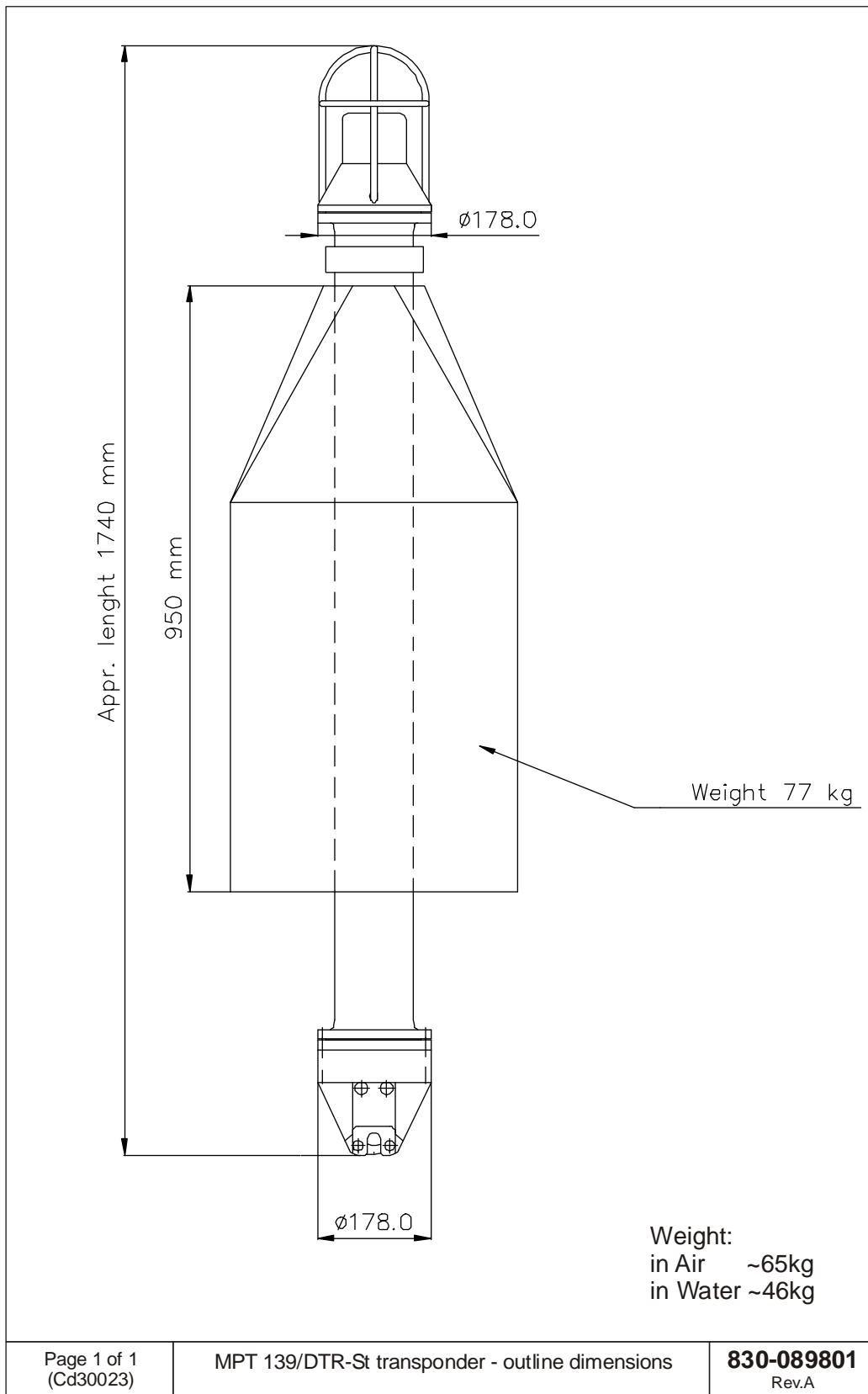

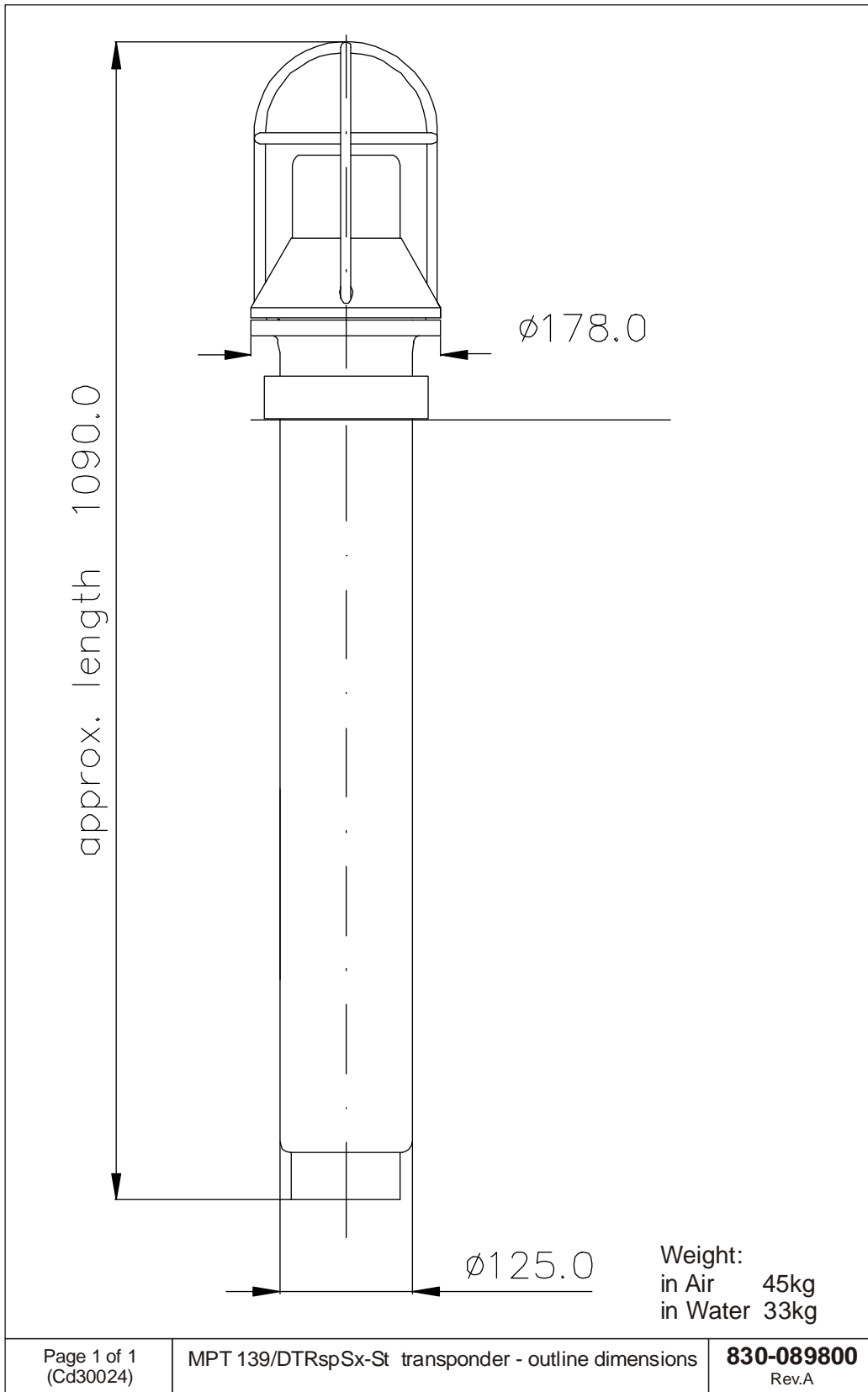

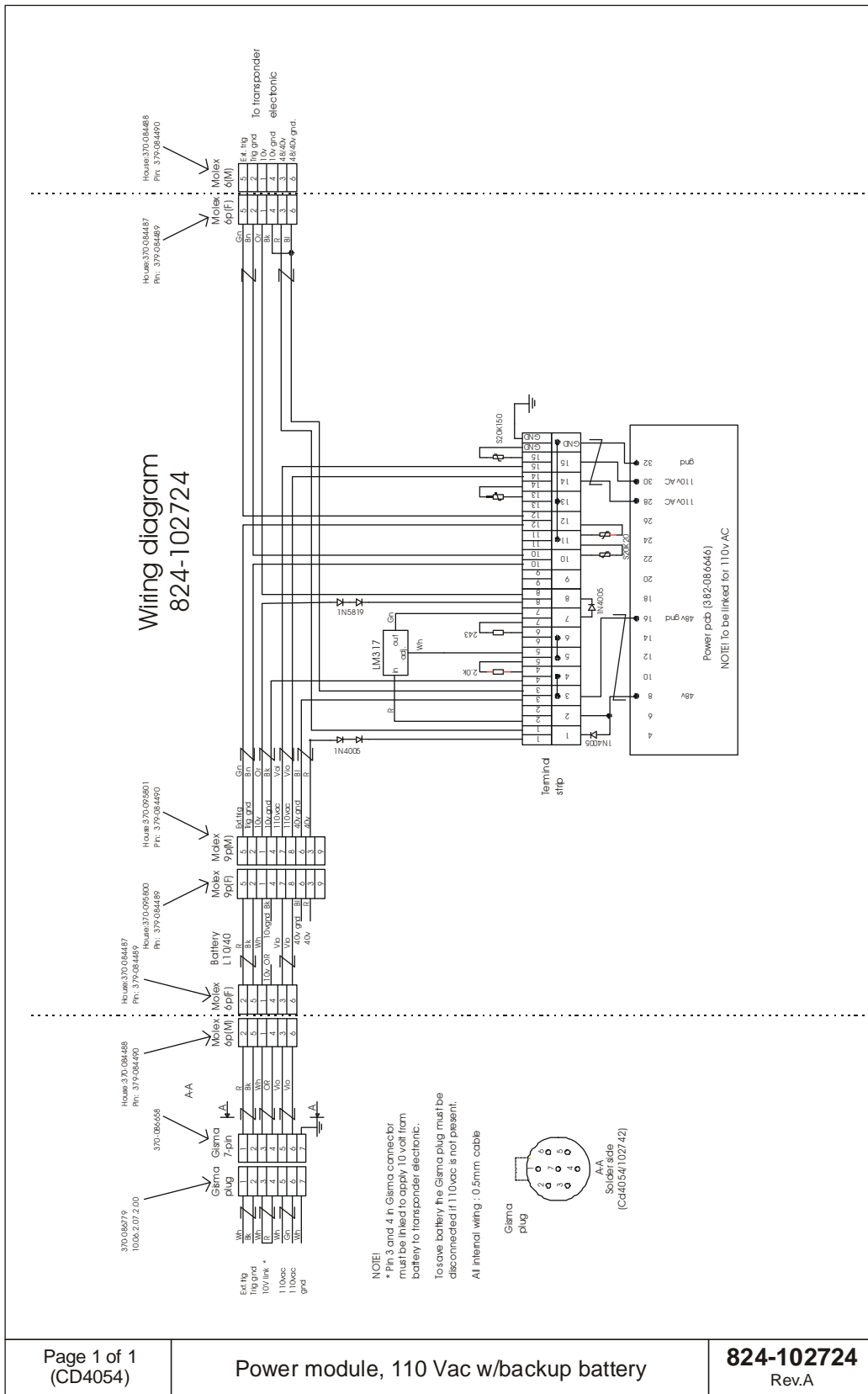

POWERMODULE

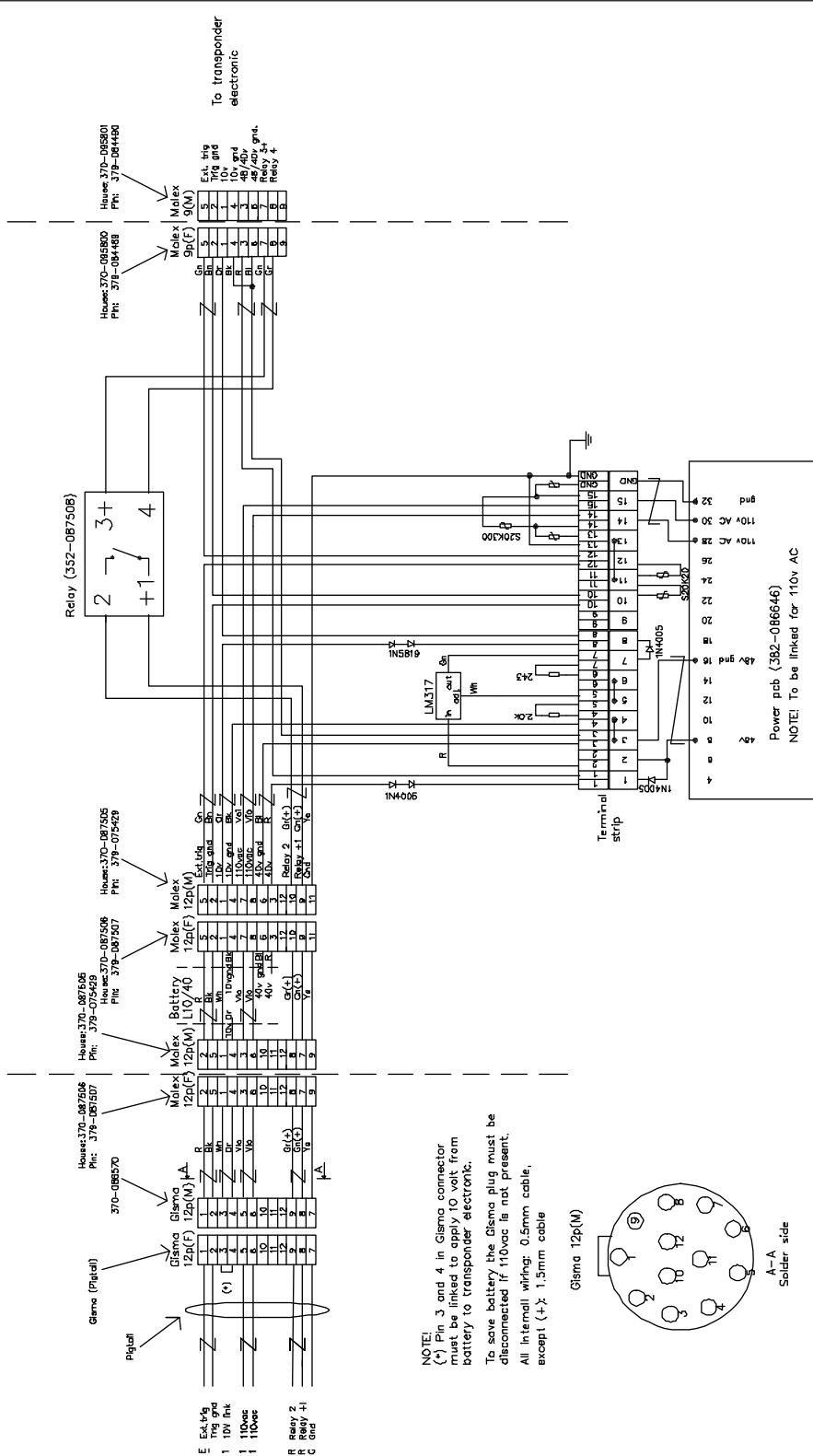

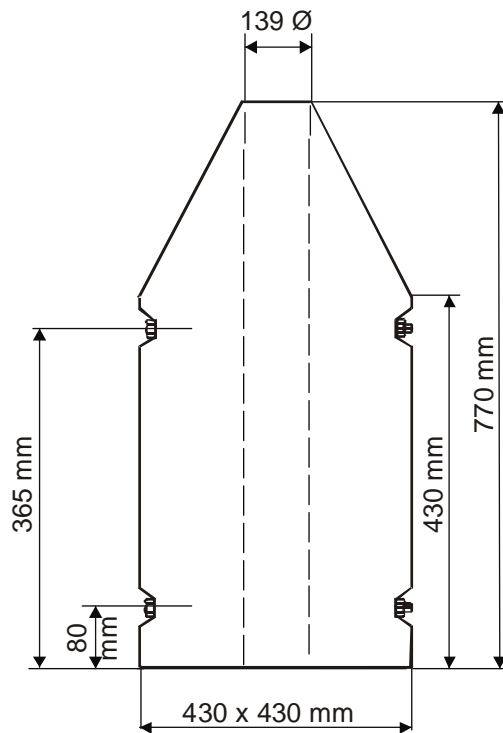

For Aluminium transponder

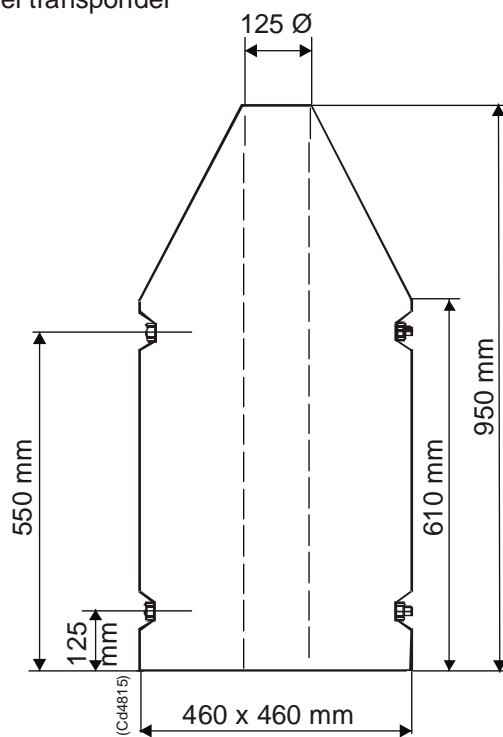

For Stainless steel transponder

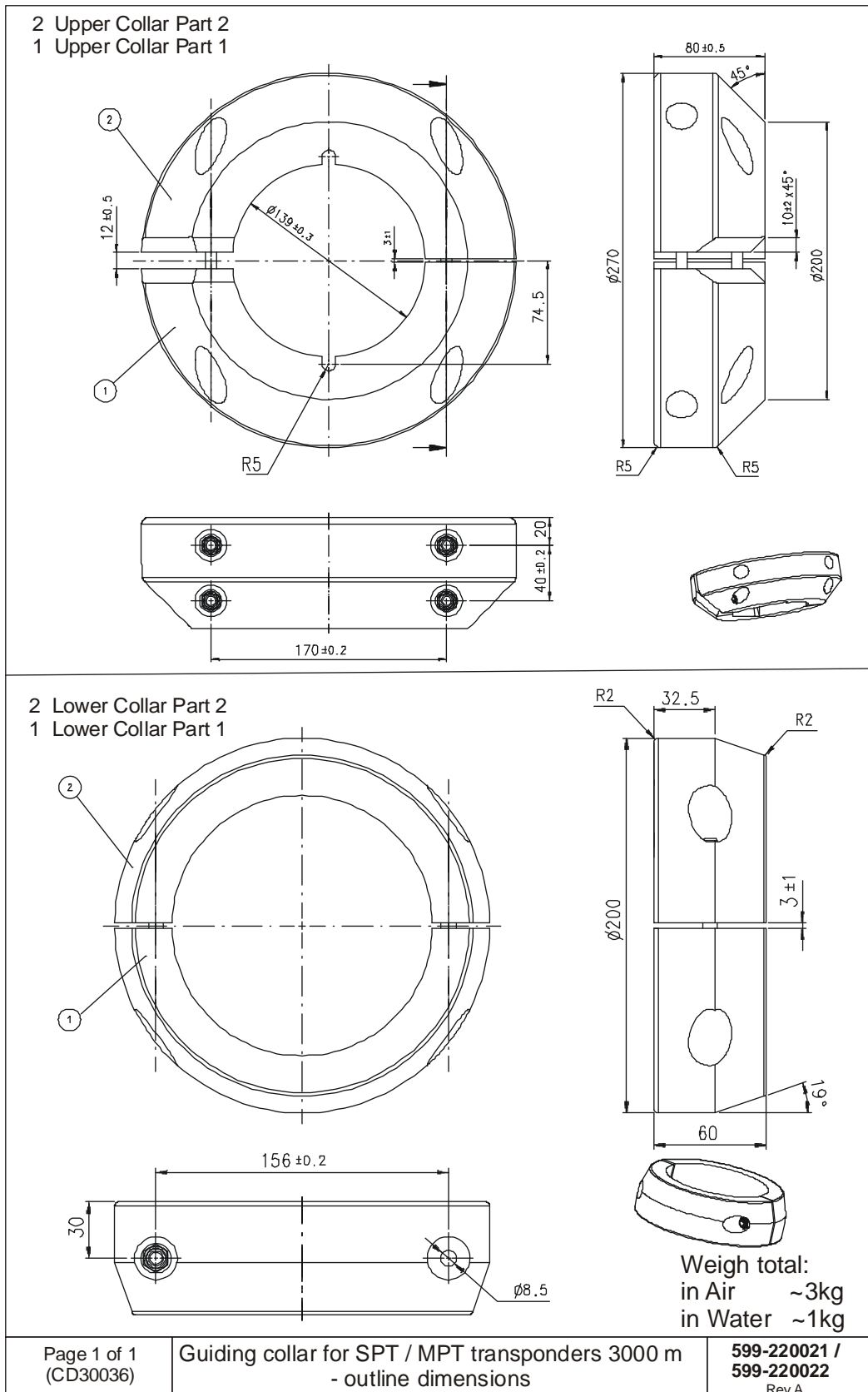

5 Upper Collar Part 2
6 Upper Collar Part 1

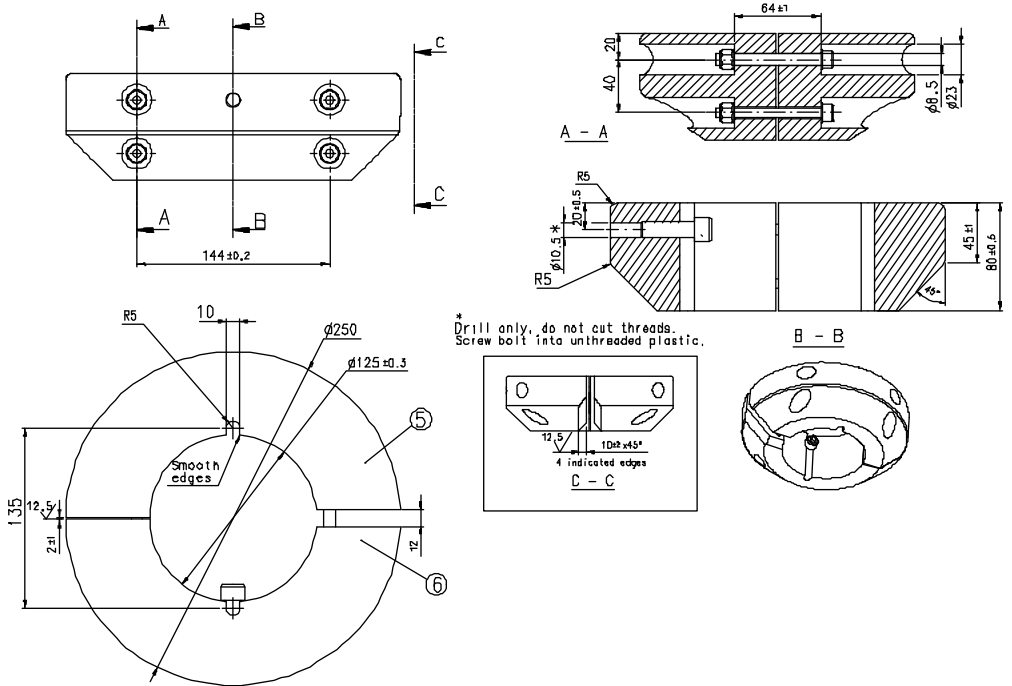

5 Lower Collar Part 2
6 Lower Collar Part 1

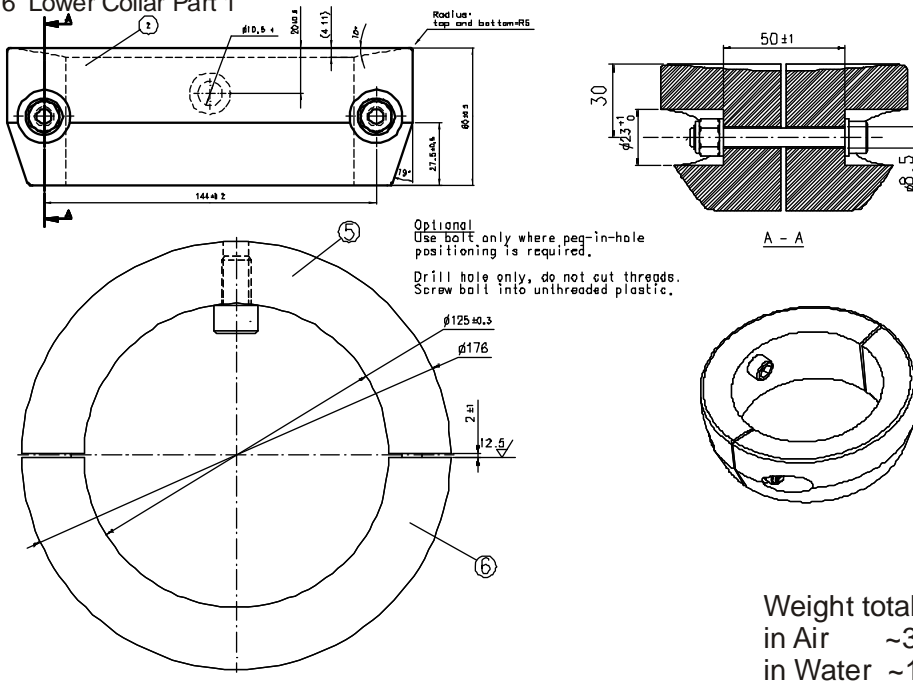

Weight total:
in Air ~3kg
in Water ~1kg

INDEX

A

Abbreviations, 1
About this manual, 1
AC/DC power unit, 70
Accessories, 86, 87
 Technical data, 87, 88
Acoustic coding, 55
Acoustic release, 6
Acoustic telemetry, 53, 54
Alkaline battery pack, 40, 46
Alkaline battery storage, 47
Anchor shackle, 35, 38
Anchor – weight, 30, 80
APOS, 28
APOS Instruction manual, 28
APOS On – line help, 31
Applications, 2, 6
 MPT specific, 6
Applications , SPT specific, 6
Assembling, 69
 Before you start, 68
Auxiliary equipment, 80
Available channels, 57
Available transponders, 7

B

Backup rings, 87
Basic model
 MPT 139, 11
 MPT 339, 11
 SPT 331, 11
Basic models, 11
Batteries, 40, 86, 88
Battery capacity, 42
Battery layout, 40, 41
Battery lifetime at operation, 40, 43
Battery lifetime at quiescent state, 47, 48

Battery pack
 Max continuous on time, 46
 Quiescent lifetime, 46
Battery packs
 Max continuous on time, 45
 Quiescent lifetime, 45
Battery replacement, 40, 41
Battery safety, 40
Battery shelf lifetime, 46, 47
Battery specification, 40
Battery storage, 45
Battery unit L24, 40
Battery weight, 22
Battery weight , 40
Beacon mode, 31
Beam patterns, 14
Before you open the unit, 63
BOP, 1
Bottom end cap, 71, 73

C

Cage, 30, 35, 36, 37
CCF, 58, 60
Channel setting, 28
Channels, 58
 MPT 139 series, 57
 SPT 133 unit, 58
 SPT and MPT 33x series, 57
Circuit boards, 71, 74
Clamp ring, 4
Common Command Frequency, 58, 59, 60
Compatibility
 13x transponders, 6
 33x transponders, 6
Configuration, 53
Connecting the battery, 27
Connecting the transponder battery, 49, 50
Contents, 1
Cylinder body, 63

D

Damage, 62
DC motor, 35
Deploy the transponder, 30
Deployment, 27, 30
Depth measurement, 6
Depth sensor, 73
Differential inclination measurement, 6
DIL switches, 54
Dismantling the transponder, 62, 63
Double inclinometer, 61
DRAWING FILE, 150
Drawings, 150
DT, 17, 18
DT sensors, 31
DTR, 17, 19

E

Electronic unit, 20
ENABLE SSBL TP, 33
End cap, 67
External connector, 17, 24
 II – interconnection, 25
 RspSx 110 Vac, 24
 RspSx 110 Vac SU, 25
External power, 61

F

Factorial coding, 55
Floating collar, 80, 81
Floating collars, 81, 151
Floating rope, 80
Frequency bands, 53, 54
Frequency shift keying, 58

G

Guiding collar, 83
 Example of use, 84
Guiding collars, 17, 21, 80, 151

H

Hazards identification, 138
Hhigh pressure hose, 33
HiPAP, 1, 31, 53
HiPAP channels, 53, 55
HiPAP compatibility, 2, 6
HiPAP system, 55
Hook, 35, 38
Housing, 63, 71, 73
Housing material, 7, 8, 10
How to handle a transponder, 2, 3
HPR, 1, 31
HPR 300 channels, 53, 58
HPR 300 command function, 58
HPR 300 frequencies, 58
 MPT 139 series, 60
 SPT 133 unit, 60
 SPT and MPT 33x series, 59
HPR 300 series, 53
HPR 300 switch settings, 58, 59
 MPT 139 series, 60
 SPT 133 unit, 60
 SPT and MPT 33x series, 59
HPR 400 channels, 53, 55, 56
Empty, 53
HPR compability, 2, 6

I

I, 17, 20
Identification, 2, 4
Identification clamp ring, 5
IFE, 58
Illustrations:
 A 7 pin and a 12 pin external connector –
 layout, 24

- Battery, 41
- Battery connector and mounting screws, 51
- Battery lifetime at operation, 44, 46, 48
- Battery lifetime at quiescent state, 45
- Connecting and mounting the battery, 50
- Connecting the battery, 49
- Example of external connector with pigtail, 29
- Example of transponder – main parts, 72
- Examples of beam patterns, 14, 15
- Examples of SPT and MPT transponders, 5
- Magnetic release mechanism, 122
- Microcontroller board – switch settings, 55
- Microcontroller circuit board – switch locations, 78
- Mounting funnel, 82
- Receiver board (Rx), 76
- Release unit, 39
- Release unit – aluminium transponder, 34
- Release unit – indicating manual release, 38
- Release unit indicating the Hook, 36
- Release unit indicating the L–arm and holdingplate, 36
- Rx amplifier matching board – block diagram, 77
- Setting the release – stainless steel transponder, 35
- Special precautions to avoid personnel injury, 3
- SPT 331 pressure housing assembly, 65
- Top view of the double inclinometer separate unit – showing the front direction, 32
- Top view of the inclinometer transponder – showing the front direction, 32
- Transducer head, indicating the two sealing screws, 67
- Transmitter circuit board, 75
- Transponder head for transponders with Depth and Temperature sensors, 73
- Transponder rack, 83
- Transponder reception and transmission signal timing diagram, 56
- Transponder with fitted guiding collar, 84
- Transponder with floating rope, 84
- Inclination measurement, 6
- Inclinometer sensors, 32
- Individual Interrogation Frequency, 58
- Initiate the double inclinometer, 61
- Input voltage, 110 Vac, 70
- Installation construction, 81

- Interconnections, 79
- Internal switches, 53

L

- LBL, 1, 80
- LBL positioning, 6
- LF, 1
- Line Replaceable Units, 85
- Lithium battery label, 17, 23, 40
- Lithium battery packs, 40, 43
- Locking shaft, 35
- Locking pin, 84
- LRUs, 85

M

- Magnetic release mechanism, 122
- Main parts, 71
- MAINTENANCE, 62
- Maximum detectable angles, 20
- ME, 1
- Micro–switch, 35
- Microcontroller board, 74, 78
- Microcontroller board (CPU), Purpose, 78
- Model, 7, 8
- Model name, 9
- Model number, 9
- Models
 - DT, 11
 - DTRDuB, 13
 - I, 12
 - II, 12
 - R, 12
 - RspSx 110 Vac, 12
 - RspSx 110 Vac SU, 12
- Motherboard, 74, 79
- Mounting, 27, 30
- Mounting brackets, 80, 81
- Mounting funnel, 81
- Mounting funnel material, 81
- Mounting the battery, 27

Mounting the transponder battery, 40
MPT, 1, 9
MPT 139, 8
MPT 139 basic transponder, Technical data, 130
MPT 139 series, 44
MPT 339 series, 44
MPT 139 Stainless steel, 151
MPT 139 transponder series, 4
MPT 139/DT transponder, Technical data, 132
MPT 139/DT – St transponder, 132
MPT 139/DTR transponder, Technical data, 134
MPT 139/DTR – St transponder, 134
MPT 139/DTRspSx 110 Vac, 44
MPT 139/DTRspSx 110 Vac transponder, Technical data, 136
MPT 139/DTRspSx 110 Vac – St transponder, 136
MPT 139/St basic transponder, 130
MPT 331, 8, 44
MPT 331 Aluminium, 150
MPT 331 Stainless steel, 150
MPT 331 transponder series, 4
MPT 331/DTDuB transponder, 127
Technical data, 124, 127, 129
MPT 331/DTDuB – St transponder, 124
MPT 331/DTRDuB transponder, 129
Technical data, 126
MPT 331/DTRDuB – St transponder, 126
MPT 339, 7
MPT 339 Aluminium, 150
MPT 339 basic transponder, Technical data, 114
MPT 339 Stainless steel, 150
MPT 339 transponder series, 4
MPT 339/DT transponder, 123
MPT 339/DTR transponder, 120
Technical data, 116, 120, 122, 123
MPT 339/DTR – St transponder, 116

MPT 339/DTRspSx 110 Vac, 44
MPT 339/DTRspSx 110 Vac transponder, 118
Technical data, 118
MPT 339/St basic transponder, 114

N

N/A, 1
Name principles, Example, 10
NC, 1
Not in operation, 30

O

O – ring, 63, 64, 68, 69, 87
On – line help, 28
Opening the pressure housing, 63
Opening the unit, 63
Operating frequencies, 57, 58
Operation, 27, 29, 30, 31
Options (names), 9
Output – Power module, 10 Vdc, 70
Output – Power module, 48 Vdc, 70
Overvoltage, 70

P

Pigtail, 27, 28, 71
Placement, 81
Positioning frequencies, 56
MPT 139 series, 57
SPT 133 unit, 58
SPT and MPT 33x series, 57
Positioning of a transponder, 27, 31
Power, 35
Power module
SPT 133/RspSx 110 Vac SU, 70, 151
SPT/MPT 110 Vac transponder, 62, 70
Power modules, wiring diagrams, 151
Power unit – 110 Vac, 70
Pre – deployment checks, 27, 28
Pressure housing assembly, 63

Preventive maintenance, 62

Pulse position coding, 58

R

Range measuring, 6

Receive sensibility, 14, 15

Receiver board, 76

Receiver board (Rx), 74

 Purpose, 76

Receiver sensitivity, 17

Rechargeable battery pack, 40, 48

Recovery, 27, 33

Related manuals, APOS Instruction manual,
28, 31

Relay, 70

Release mechanism, 12, 27, 30, 35, 36, 64
 Operation, 35

Release mechanism unit, 93
 Technical data, 93

Release unit, 67, 71, 73

Release units, 17, 18

Remove the bottom end cap, 62, 67

Remove the release unit, 62, 67

Replacement

 Batteries, 62

 Microcontroller board, 65

 Motherboard, 66

 Rx board, 65

 Rx–amplifier matching board, 66

 Transponder battery, 51

Replacement of circuit boards, 62, 65

Replacement of the battery, 27

Replacement of the transponder battery, 40

Replacement transducer

 MPT 139 series, 66

 MPT 331 series, 67

 MPT 339 series, 66

 SPT 133 unit, 66

 SPT 331, 67

Reset, 52

Resolution, 20

Responder, 61

Responder connector, 64

Responder function, 6, 27, 33

Responder trigger connector, 64

Revolution, 35

Rotary switches, 54

ROV, 1, 80

Rx, 76

Rx amplifier board, 74

Rx frequencies, 57

S

Screwed flange, 63

Sealing screws, 67

Sealing surfaces, 64

Self positioning, 6

Sensitivity, 14, 15

Sensors, 18, 86, 88

Setting the release mechanism, 35, 38

Silica–gel, 69

Silica–gel bag, 50, 52

Socket–head screws, 68

Soldering, 66

Source level, 17, 69

Source level adjustment, 62, 69

Spare parts, 85

SPT, 1, 9

SPT 133, 7

SPT 331, 7

SPT 133, 11

SPT 133 Stainless steel, 150

SPT 133 transponder unit, 4

SPT 133/RspSx 110 Vac SU, 44

SPT 133/RspSx 110 Vac SU transponder, 110
 Technical data, 110

SPT 331, 44

SPT 331 Aluminium, 150

SPT 331 basic transponder, 104

SPT 331 Stainless steel, 150

SPT 331 transponder series, 4

SPT 331/I transponder, Technical data, 89,
95, 104, 108

- SPT 331/I – St transponder, 95
- SPT 331/II separate inclinometer unit,
Technical data, 99
- SPT 331/II transponder, Technical data, 97
- SPT 331/II – St separate inclinometer unit, 99
- SPT 331/II – St transponder, 97
- SPT 331/R transponder, 91, 106
Technical data, 91, 106
- SPT 331/RspSx 110 Vac, 44
- SPT 331/RspSx 110 Vac transponder, 86, 108
Technical data, 102
- SPT 331/RspSx 110 Vac – St transponder, 102
- SPT 331/St basic transponder, 89
- SSBL, 1, 80
- SSBL positioning, 6
- Stainless steel transponders, 20
- Storage, 27, 34, 39, 69
- Subsea SPT/MPT battery unit, 40
- Switch settings, 53, 54
- System set – up, 27, 28
- T**
- Tables
- Double inclinometer external connector, 25
 - Frequency bands, 54
 - MPT 139 series – HPR 300 channel numbers and frequencies, 60
 - MPT 139 series – HPR 300 switch settings, 60
 - MPT 139 series – HPR 400 switch settings, 57
 - RspSx 110 Vac SU base external connector, 26
 - RspSx 110 Vac SU top external connector, 26
 - SPT and MPT 33x – HPR 300 frequencies and switch settings, 59
 - SPT and MPT 33x series – HPR 300 switch settings, 59
 - SPT and MPT 33x series – HPR 400 switch settings, 57
 - Standard external connector, 25
- TECHNICAL SPECIFICATIONS, 17
- Technical specifications
- Floating collars, 17, 21
 - Model/DuB, 17, 19
 - Model/II, 17, 20
 - Model/R, 17, 19
 - Model/RspSx 110 Vac, 17, 19
 - Model/SU, 17, 20
 - Mounting brackets, 17, 21
- Telemetry frequencies, 57
- Telemetry link, 55
- Telemetry of sensor data, 6
- Temperature measurement, 6
- Temperature sensor, 73
- temperature variations, 69
- Testing, 62, 63
- TP, 1
- Transducer, 30, 71, 73
- Transducer cage, 63
- Transducer handling, 62, 69
- Transducer head, 63
- Transducer unit, 20, 112
Technical data, 112
- Transducer unit of the SPT 133/RspSx 110 Vac SU – St transponder, 112
- Transmitter board, 75
- Transmitter board (Tx), 74
- Transponder assembly, 62, 68
- Transponder channels, 53
- Transponder design, 4
- Transponder in use, 27, 31
- Transponder model identification principles, 2, 9
- Transponder models description, 2, 11
- Transponder rack, 83
- Transponder safety information, 138
- Transponder series, 7, 8
- Transponder Test and Configuration Unit, 28
- Transportation, 69
- Trigger pulse, 33
- TTC 400, 28
- TTC 400 Instruction manual, 28
- TTC 400 Quick Reference Guide, 28
- Tx, 75
- Tx board, 65
- Tx frequencies, 57

W

Wires, 64

