

Installation manual

Simrad EK60 Scientific echo sounder

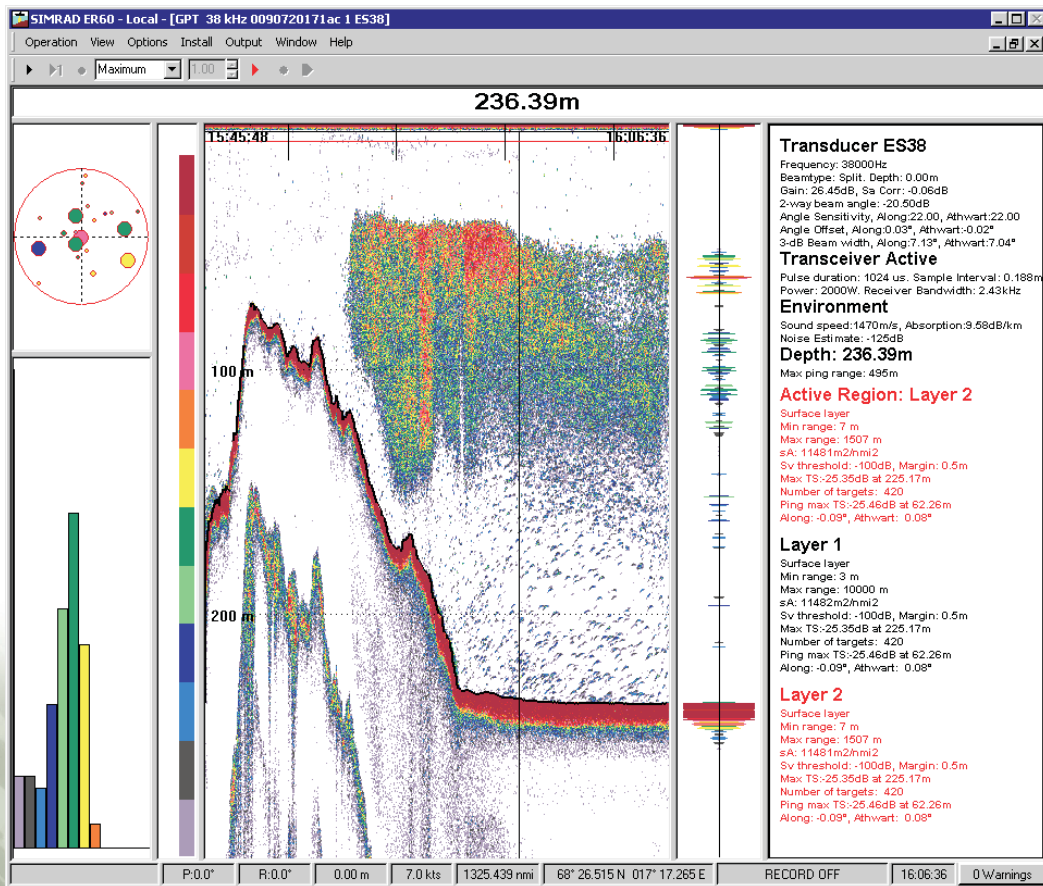



Simrad EK60

Scientific Echo Sounder

Installation manual

This manual provides you with the basic information required to install the Simrad EK60 Scientific Echo Sounder. The information is intended for qualified personnel such as naval architects, shipyard engineers and skilled workers.

For information about the practical use of the product, refer to the Simrad EK60 *Quick start guide*, the Simrad EK60 *Reference manual*, or the context sensitive on-line help.

Caution _____

You must never power up the EK60 when the ship is in dry dock. The transducers(s) will be damaged if the EK60 transmits in open air.

Document information

- **Product:** Simrad EK60
- **Document:** Installation manual
- **Document number:** 850-164696
- **Revision:** B
- **ISBN:** xxx
- **Date of issue:** 31 October 2015

Copyright

The information contained in this document remains the sole property of Kongsberg Maritime AS. No part of this document may be copied or reproduced in any form or by any means, and the information contained within it is not to be communicated to a third party, without the prior written consent of Kongsberg Maritime AS.

Warning

The equipment to which this manual applies must only be used for the purpose for which it was designed. Improper use or maintenance may cause damage to the equipment and/or injury to personnel. The user must be familiar with the contents of the appropriate manuals before attempting to operate or work on the equipment.

Kongsberg Maritime disclaims any responsibility for damage or injury caused by improper installation, use or maintenance of the equipment.

Disclaimer

Kongsberg Maritime AS endeavours to ensure that all information in this document is correct and fairly stated, but does not accept liability for any errors or omissions.

Support information

If you require maintenance or repair, contact your local dealer. You can also contact us using the following address: simrad.support@simrad.com. If you need information about our other products, visit <http://www.simrad.com>. On this website you will also find a list of our dealers and distributors.

Table of contents

ABOUT THIS MANUAL	9
SIMRAD EK60	11
Important.....	12
System description.....	13
System diagram.....	15
Main system units	17
Display description.....	17
Processor Unit description.....	18
Ethernet switch.....	19
General Purpose Transceiver (GPT) description.....	19
Transducers.....	20
Split beam, wideband and depth rated transducers.....	21
Split beam transducers.....	21
Wideband transducers.....	22
Depth rated transducers.....	22
Physical dimensions versus beam opening	23
Scope of supply.....	25
Basic items provided with a standard delivery.....	25
Additional required items.....	26
Additional optional items	27
General safety rules.....	28
Installation requirements.....	29
Supply power requirements.....	29
Uninterrupted Power Supply (UPS) requirements.....	29
Basic wiring requirements.....	29
Compass deviation requirements.....	30
Noise sources.....	30
Dry docking requirements.....	30
Classification approval requirements	30
Network security.....	31
Support information.....	32
PREPARATIONS	34
Installation summary.....	35
About installation drawings.....	36
Necessary tools and equipment for EK60 installation.....	37
Requirements for shipyard worker skills.....	37
Where to install the transducer	38

Introduction	38
Mount the transducer deep	38
Avoid protruding objects	39
Stay far away from the propellers	39
Choose a position far away from the bow thruster(s)	39
Summary and general recommendations	40
Acoustic noise	41
Contributing factors	41
Self noise	43
Ambient noise	45
Fishing gear noise	45
Electrical noise	46
Some means to reduce acoustic noise	46
INSTALLING THE EK60 HARDWARE UNITS	49
Installing the General Purpose Transceiver (GPT)	50
Installing the General Purpose Transceiver (GPT) power supply	51
Installing the display	53
Installing a commercial computer	54
Installing the Enix Processor Unit	55
Installing the transducer(s)	58
CABLE LAYOUT AND INTERCONNECTIONS	59
Read this first	60
Cable plans	61
About the cable plans	61
Topside computer cable plan	62
Single General Purpose Transceiver (GPT) cable plan	64
Dual General Purpose Transceiver (GPT) cable plan	66
List of EK60 cables	67
Transceiver interfaces	70
AC mains input	70
DC input	71
Auxiliary interface socket	71
Ethernet AUI connector	74
Ethernet RJ45 connector	74
Transducer connector	75
Graphic adapter	76
Moxa CP114EL-I serial port adapter	78
Moxa CP114EL-I overview	78
Moxa CP114EL-I connectors	79
Using a steel conduit to protect the transducer cable	79

Cable drawings and specifications	81
AC mains power cable using IEC C13 inline socket	82
Generic RS-232 connection using three wires	84
Generic RS-232 connection using five wires	85
RS-232 used as synchronization trigger (input or output)	86
Generic RS-422 serial line using five wires	87
Generic RS-485 connection using two or four wires	88
Moxa CP114EL-I Serial line adapter	89
RJ45 High speed Ethernet cable (1000Base-t).....	91
General Purpose Transceiver (GPT) external power supply	92
General Purpose Transceiver (GPT) remote on/off.....	93
General Purpose Transceiver (GPT) transmit synchronization.....	95
Single beam low power transducer connection to a GPT Transducer socket	96
Single beam high power transducer connection to a GPT Transducer socket	97
Dual single beam transducer connection to a GPT Transducer socket	98
Split beam transducer; connections and specifications	100
Split beam transducer to single beam output on GPT Transducer socket.....	102
Split beam transducer connection to a GPT Transducer socket wired for single beam high output	103
Transducer 12-16/60 connection to a GPT Transducer socket.....	105
Transducer ES18 connection to a GPT transducer socket.....	106
Transducer ES38-7 connection to a GPT transducer socket	107
Transducer ES38-10 connection to a GPT Transducer socket.....	108
Transducer 38/200 Combi C connection to a GPT Transducer socket	109
Transducer ES38-18/200-18C connection to a GPT transducer socket.....	111
Transducer 50/200 Combi C connection to a GPT Transducer socket	112
Transducer ES70-18CD connection to a GPT Transducer socket.....	114
Burton underwater connectors on split beam transducers for deep water.....	115
About serial lines.....	117
Basic cable requirements	120
Cable trays	120
Radio frequency interference	121
Physical protection of cables.....	121
Grounding of system cables	121
Cable connections and terminations.....	122
Cable identification.....	122
Cable glands and termination procedures	123
SETTING UP THE INTERFACES TO PERIPHERAL DEVICES.....	128

About NMEA and standard datagram formats	129
About the NMEA datagram formats	129
National Marine Electronics Association (NMEA)	129
NMEA sentence structure	130
Standard NMEA 0183 communications parameters	131
Interfacing peripheral equipment	132
Setting up the Ethernet data output	132
Setting up the input from a motion sensor	133
Setting up the input from a trawl system.....	134
Setting up the input from a catch monitoring system.....	135
Setting up the input from a navigation system	136
Setting up a serial line annotation input	139
Setting up depth output to an external system.....	140
Setting up depth output to a Simrad sonar	142
Synchronization with other hydroacoustic systems	145
About synchronization	145
Synchronization using a serial line.....	146
Synchronization using the Auxiliary plug.....	147
EK60 set up in <i>Slave</i> mode.....	148
EK60 set up in <i>Master</i> mode	149
SETTING TO WORK.....	151
Setting to work summary	152
Verifying that the EK60 is ready for operational use.....	153
Verifying that operational power is correct	153
Verifying that all cables are properly connected	154
Visual inspection of the display.....	154
Visual inspection of the Processor Unit	157
Visual inspection of the General Purpose Transceiver (GPT).....	158
Powering up the EK60 for the first time	160
Setting up summary	160
Installing the EK60 operational software.....	161
Defining the IP address on the Processor Unit network adapter for communication with the General Purpose Transceiver (GPT).....	162
Installing transceiver channels	163
Adjusting the screen resolution	164
System test procedures.....	165
Installation remarks.....	166
DRAWING FILE.....	167
About the drawings in the drawing file.....	168
General Purpose Transceiver (GPT) outline dimensions.....	169

GPT Power supply outline dimensions.....	172
Processor Unit outline dimensions	175
GPT Transducer connector wiring.....	179
TECHNICAL SPECIFICATIONS.....	180
Introduction to technical specifications	181
Performance specifications	181
Interface specifications.....	182
Weights and outline dimensions	185
Power requirements	187
Environmental requirements.....	188
Minimum computer requirements.....	189
Minimum technical requirements for display	190
EQUIPMENT HANDLING.....	192
Transporting Kongsberg Maritime equipment.....	193
Lifting units and transportation boxes	194
Inspection of units and transportation boxes after arrival.....	195
Specifications for storage prior to installation or use.....	196
Unpacking instructions	197
Unpacking standard parts and units.....	198
Unpacking mechanical units	199
Unpacking electronic and electromechanical units	200
Unpacking transducers	201
Specifications for storage after unpacking.....	202
Packing instructions for storage or shipping.....	203
Storage after use.....	204
Cleaning an electronic cabinet or unit.....	204
Cleaning a mechanical or electromechanical unit.....	205
Handling instructions for printed circuit boards and electronic modules.....	206
Circuit board unpacking and handling	207
Returning a printed circuit board or an electronic module to Kongsberg Maritime	208
About Electrostatic Discharge (ESD).....	209
Disposal of old products	211

About this manual

Purpose of manual

The purpose of this manual is to provide the information, procedures and basic drawings required for the physical installation of the Simrad EK60.

Target audience

The manual is intended for technical personnel; such as skilled shipyard workers, electricians, qualified engineers and naval architects. It is assumed that you understand the general principles of maritime electronic equipment. You must also be familiar with computer hardware, interface technology and installation of electronic and mechanical products.

We assume that you are familiar with the basic acoustic principles of sound in water, and that you have some experience with scientific use of sonars and/or echo sounders.

Installation instructions

You must follow the instructions in this manual to ensure optimal performance. As a guide, installation procedures are presented in the order they must be done.

The equipment described in this manual includes the complete system with relevant cabinets. Units provided locally by the customer, installation shipyard or local representative are not described.

The manual also defines the equipment responsibility, and provides applicable instructions for unpacking and storage of units.

Note

You must follow the instructions given in this manual. If not it may affect the warranty. Kongsberg Maritime AS will accept no responsibility for any damage or injury to the system, vessel or personnel caused by equipment that has been incorrectly installed or maintained, or by drawings, instructions or procedures that have not been prepared by us.

Installation drawings

The customer, or the shipyard contracted to do the installation, must provide relevant detailed vessel specific mechanical drawings.

Note

If required, all drawings provided by the shipyard for the physical installation of the EK60 must be approved by the vessel's national registry and corresponding maritime authority and/or classification society. Such approval must be obtained before the installation can begin. The shipowner and shipyard doing the installation are responsible for obtaining and paying for such approval.

Kongsberg Maritime AS may, on special order, provide assistance to these drawings.

Applicable generic outline dimension and/or production drawings are provided in the *Drawing file* chapter. Drawings may also be downloaded in PDF and/or DWG formats from our website.

- <http://www.simrad.com/ek60>

License information

The EK60 is not a licensed product.

Registered trademarks

Observe the registered trademarks that apply.

Simrad®, SIMRAD® and the Simrad® logo are either registered trademarks, or trademarks of Kongsberg Maritime AS in Norway and other countries.

Windows®, Windows XP®, and Windows® 7 are either registered trademarks, or trademarks of Microsoft Corporation in the United States and/or other countries.

Simrad EK60

Topics

[Important, page 12](#)

[System description, page 13](#)

[System diagram, page 15](#)

[Main system units, page 17](#)

[Split beam, wideband and depth rated transducers, page 21](#)

[Scope of supply, page 25](#)

[General safety rules, page 28](#)

[Installation requirements, page 29](#)

[Network security, page 31](#)

[Support information, page 32](#)

Important

As with all other advanced instruments, there are a few important things that you must be aware of.

Before you switch on the EK60

Before you power up the EK60, make sure that the transducer is submerged in water!

Caution

You must never power up the EK60 when the ship is in dry dock. The transducer will be damaged if it transmits in open air.

When the EK60 is not used

When you do not use the EK60, switch off the display and the Processor Unit.

If you know that you will not use the EK60 for a long time, we recommend that you also switch off the transceiver(s). Since each transceiver is not provided with a power switch, you must either disconnect the power cable, or disengage the relevant circuit breaker(s).

When you are docking your vessel

If the transducer is activated when out of water it may be damaged beyond repair. It is therefore very important that the EK60 system remains switched off when the vessel is in dry dock, and that no one tries to use it.

To ensure that this can not happen, disconnect the power supply cable to the either the Processor Unit or the transceiver(s) - or both! You may also remove the circuit breakers on the AC mains supply to the EK60 transceiver(s). Do this before the vessel is placed in the dry dock!

As an extra safety measure, the EK60 is by default powered up with the transmit power disabled.

If something breaks down

If you believe that something has broken down, contact your local dealer. They will be able to assist. A list of all our dealers is provided on our website.

- <http://www.simrad.com>

If you are unable to contact a dealer, observe the support information in this manual.

When you wish to switch off the EK60

You must NEVER switch off the EK60 by means of the on/off switch on the Processor Unit. You must ALWAYS exit the EK60 program by clicking **Exit** on the **File** menu.

WARNING

If you power down the EK60 by means of the power switch on the Processor Unit you may damage the software program and the interface parameters used to communicate with external devices.

Transducer handling

A transducer must always be handled as a delicate item. Wrongful actions may damage the transducer beyond repair.

Observe these rules:

- **Do not** activate the transducer when it is out of the water.
- **Do not** lift the transducer by the cable.
- **Do not** step on the transducer cable.
- **Do not** handle the transducer roughly, avoid impacts.
- **Do not** expose the transducer to direct sunlight or excessive heat.
- **Do not** use high pressure water, sand blasting, metal tools or strong solvents to clean the transducer face.

Related topics

[Support information, page 32](#)

[Network security, page 31](#)

System description

The Simrad EK60 is an advanced scientific echo sounder. Based on more than 60 years of research and development in close collaboration with leading marine scientists this echo sounder system has become an international standard for fish stock assessment.

Key features include:

- High dynamic range
- Raw data recording
- Low self noise
- High ping rate
- Multi frequency application for species identification
- Simultaneous transmission of all frequencies
- Several frequencies covering same sampling volume
- Remote control
- Store and reload personal settings

- Data server interface for raw data recording

The Simrad EK60 can operate seven echo sounder frequencies simultaneously ranging from 18 to 710 kHz. A wide selection of high quality accurate transducers is available.

The Simrad EK60 is a split-beam Microsoft® Windows® operated echo sounder with built-in calibration. It is specifically suited for permanent installation onboard a research vessel. It is still compact and a natural choice for portable use. The portable version Simrad EY60 is provided in a rugged case.

The echo sounder system is modular, and you can assemble any combinations of transceivers and transducers to fit your research purposes. In a typical configuration, the EK60 will comprise:

- One colour display
- One Processor Unit (personal computer)
- An Ethernet switch
- One or more transceiver units
- One or more transducers

Real time echo integration and target strength analysis in an unlimited number of layers is provided as well as storage of raw data for replay or analysis in one of several post-processing software packages. Several post-processing alternatives are available for rapid survey analysis and reporting.

Related topics

[System diagram, page 15](#)

System diagram

The system diagram identifies the main components of a basic EK60 system, as well as the connections between the units. Interface capabilities and power cables are not shown.

The basic Simrad EK60 scientific echo sounder system consists of one transducer, one General Purpose Transceiver (GPT) and one Processor Unit (computer). In addition to this, the system is provided with the ER60 scientific echo sounder program.

Additional transceivers and transducers can be added to meet your operational and functional requirements.

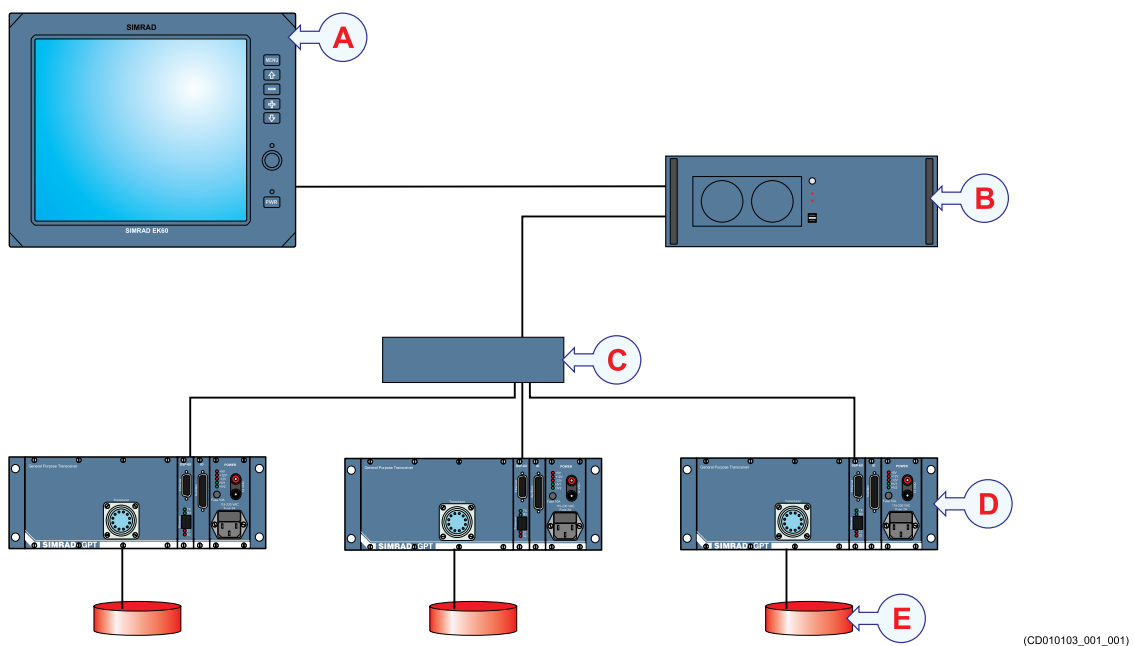

In a Simrad EY60 system, the display and the Processor Unit computer are replaced with a powerful laptop computer.

Note

The Simrad BI60 post-processing software used to be a part of the EK60. This software product is no longer supported.

Post-processing software applications may be provided from third party suppliers. See our website for more information.

- <http://www.simrad.com>

Note

Unless otherwise specified in a contract, the display and the Ethernet switch are not included in the standard delivery from Kongsberg Maritime. These are commercial items that can be purchased locally.

Related topics

[System description, page 13](#)

Main system units

Topics

[Display description, page 17](#)

[Processor Unit description, page 18](#)

[Ethernet switch, page 19](#)

[General Purpose Transceiver \(GPT\) description, page 19](#)

[Transducers, page 20](#)

Display description

A display is a required part of the Simrad EK60 Scientific Echo Sounder system.

Any commercial display can be used with the EK60 Scientific Echo Sounder, provided that the display meets the minimum requirements. If you intend to use many views simultaneously, we suggest that you purchase a large high-resolution display.

Note

The display is not a standard part of the EK60 delivery.

The chosen display must be designed for maritime use, and it must meet the minimum performance specifications. You must also make sure that the chosen display supports the video formats provided by the Processor Unit.

Tip

If you wish to see several EK60 views simultaneously, you may wish to obtain a large display with high resolution. The EK60 software supports all display sizes. The fidelity of your presentations depends on the resolution and quality of the graphic adapter in the computer, as well as the quality of the display.

Related topics

[Minimum technical requirements for display, page 190](#)

Processor Unit description

The Processor Unit is the computer that controls the EK60 system. It is a vital part of the Scientific Echo Sounder system.

Note

The Processor Unit is not a standard part of the EK60 delivery.



In this publication, the computer is referred to as the Processor Unit.

The operating system must be Microsoft Windows® 7.

The computer must be designed for rugged use, and the construction must be able to withstand the vibrations and movements of a vessel.

The computer must comply to the requirement specifications provided by Microsoft for their operating systems. It must also provide the necessary interface facilities (serial lines and Ethernet connections) that your EK60 will need to communicate with peripheral systems.

A high quality Ethernet adapter is required.

The Ethernet adapter communicating with the General Purpose Transceiver (GPT) must offer a **Receive Buffers** function. This parameter must be set to its maximum value if more than one General Purpose Transceiver (GPT) is used.

The Processor Unit is normally mounted on the bridge or in a scientific laboratory.

Tip

A suitable computer may be provided with the EK60 system.

The computer is designed for rugged use, and customized by Kongsberg Maritime. Except from the fans, it contains no moving parts. It is based on a commercial design, but the software and hardware has been specified and assembled by Kongsberg Maritime to suit the EK60 requirements.

It is set up with all necessary software.

The computer holds multiple USB ports for use with future software upgrades.

These USB ports will also allow you to export screen captures and recorded data from the EK60.

Consult your dealer or agent for more information.

Related topics

[Additional required items, page 26](#)

[Processor Unit outline dimensions, page 175](#)

[Minimum computer requirements, page 189](#)

Ethernet switch

A high capacity Ethernet switch is a key component of the EK60 system.

If you use more than one General Purpose Transceiver (GPT) in your EK60 system, you must use an Ethernet switch to connect each General Purpose Transceiver (GPT) to the Processor Unit.

The Ethernet switch is by default not included in the EK60 delivery, but this is a commercial item that can be purchased locally.

Note

Make sure that your selected switch has a large bandwidth capacity. Minimum 1 Gb (1000BASE-T) is required. You must also make sure that all Ethernet cables are type Cat 5e or better. A slower switch - or low quality cables – will decrease the operational performance of the EK60.

1000BASE-T (also known as IEEE 802.3ab) is a standard for gigabit Ethernet over copper wiring. Each 1000BASE-T network segment can be a maximum length of 100 meters (330 feet), and must use Category 5 cable or better (including Cat 5e and Cat 6).

Wikipedia, April 2014

Related topics

[Additional required items, page 26](#)

General Purpose Transceiver (GPT) description

The EK60 General Purpose Transceiver (GPT) is provided to transmit the acoustic energy into the water. To do this, the transceiver computes and generates the electric signals sent to the transducer to form a transmission - a 'ping'. After each transmission, it will receive the echoes from the objects in the water column and/or the seabed. These echoes are filtered and amplified, and then converted to digital format.

The EK60 General Purpose Transceiver (GPT) comprises a rugged box providing all necessary transmitter and receiver electronics.

The receiver is designed for low noise, and it can handle input signals spanning a very large instantaneous dynamic amplitude range. All targets are correctly measured and displayed.



A high quality Ethernet cable connects the General Purpose Transceiver (GPT) to the Processor Unit. The distance between the Processor Unit and the transceiver can be extended up to maximum 70 meters. If a longer cable is required, cut it in half, and insert an Ethernet switch to provide buffer amplification.

If more than one General Purpose Transceiver (GPT) is used, a small high capacity Ethernet switch is required to connect the transceivers to the Processor Unit.

In order to avoid electrical noise, certain transceiver configurations are supplied with an external power supply.

Related topics

[Basic items provided with a standard delivery, page 25](#)

[General Purpose Transceiver \(GPT\) outline dimensions, page 169](#)

[GPT Power supply outline dimensions, page 172](#)

Transducers

The EK60 Scientific Echo Sounder can be used with all our single beam and split beam transducers.

Kongsberg Maritime can provide a large range of efficient and accurate Simrad transducers for fishery and fishery research applications.

A wide range of operational frequencies is available.

Simrad transducers are designed to work optimally across a large bandwidth and in demanding environments. For scientific echo sounders, we divide the features of the transducers into three main categories; split beam, wideband and depth rated. Several transducers will fit more than one category.

For more information about the transducers provided by Kongsberg Maritime, consult the Simrad website.

- <http://www.simrad.com>

The installation of the transducer (or transducers) is not described in detail in this manual. Please refer to the documentation provided with each transducer.

Related topics

[Split beam transducers, page 21](#)

[Wideband transducers, page 22](#)

[Depth rated transducers, page 22](#)

[Physical dimensions versus beam opening, page 23](#)



Split beam, wideband and depth rated transducers

Simrad transducers are designed to work optimally across a large bandwidth and in demanding environments. For scientific echo sounders, we divide the features of the transducers into three main categories; split beam, wideband and depth rated. Several transducers will fit more than one category.

Topics

[Split beam transducers, page 21](#)

[Wideband transducers, page 22](#)

[Depth rated transducers, page 22](#)

[Physical dimensions versus beam opening, page 23](#)

Split beam transducers

A split beam transducer is design to transmit the acoustic pulse using one beam, while receiving the echoes in three or four individual channels.

Variations in phase of the returned echoes enable us to locate the target within the acoustic beam. Once you know the location of a target you can make up for variations in the beam patterns, and in the end you can record calibrated target tracks within the acoustic beam.

Simrad commercialized this technology in the 1980's. Our split beam echo sounders are now used to record data for marine resource management worldwide.

For more information about the split beam transducers provided by Simrad, consult our website.

- <http://www.simrad.com>

The following split beam transducers are recommended for the Simrad EK60 Scientific Echo Sounder.

Model	Order number	Nominal frequency (kHz)	Opening angle	Material
ES18	KSV-088694	18	11°	Ceramic
ES38-10	KSV-202714	38	10°	Ceramic
ES38-7	321842	38	7°	Ceramic
ES70-7C	KSV-203678	70	7°	Composite
ES120-7C	KSV-204580	120	7°	Composite
ES200-7C	KSV-203003	200	7°	Composite
ES333-7C	322598	333	7°	Composite

The installation of the transducer (or transducers) is not described in detail in this manual. Please refer to the documentation provided with each transducer.

Related topics

[Transducers, page 20](#)

[Additional required items, page 26](#)

Wideband transducers

A wideband transducer can transmit and receive on a large frequency range, for example 45 to 90 kHz, 85 to 170 kHz or 150 to 300 kHz. This means you only need three transducers to cover the entire frequency range from 45 to 300 kHz.

In order to design a transducer that is capable of providing this frequency range, composite technology is our preferred production technique. All our wideband transducers are produced using composite material.

When a wideband transducer is combined with a wideband transceiver it is possible to make sweep transmissions. In these, the transmit frequency continuously increases throughout the transmitted pulse. This functionality is often referred to as a "chirp".

It is also possible to transmit on several discrete frequencies, one at a time.

If you are an advanced user, you can define an arbitrary signal, such as a dolphin's click. This opens up a whole new world in interpretation of the echo, taking a great step forward towards the goal of providing a species identification echo sounder, or "ecosounder".

For more information about the wideband transducers provided, consult the Simrad website.

- <http://www.simrad.com>

Note

The Simrad EK60 Scientific Echo Sounder does not support wideband transmission and reception.

The installation of the transducer (or transducers) is not described in detail in this manual. Please refer to the documentation provided with each transducer.

Related topics

[Transducers, page 20](#)

[Additional required items, page 26](#)

Depth rated transducers

Sometimes collecting data from a vessel simply does not do the job for you. Perhaps you need to place the transducer in deeper waters closer to the target for better resolution.

You must then use a transducer that can handle the increased water pressure.

If it is necessary to place the transducer in deeper waters, you can use a towed body. You can also place the transducer on the seabed for long term collection of data. We have for many years designed and built transducers for deep water applications like this. Our series of 7° depth rated transducers have standard depth rating to 1500 meters. We can also build transducers for greater depths.

For more information about the depth rated transducers provided, consult the Simrad website.

- <http://www.simrad.com>

The following depth rated transducers are recommended for the Simrad EK60 Scientific Echo Sounder. Note that all these are also split beam transducers. Standard depth rating is 1500 meters. If you need to work on larger depths, feel free to contact us for advice.

Model	Order number	Nominal frequency (kHz)	Opening angle	Material
ES38DD	KSV-113392	38	7°	Ceramic
ES70-7CD	335039	70	7°	Composite
ES70-18CD	321637	70	18°	Composite
ES120-7CD	324410	120	7°	Composite
ES200-7CD	KSV-207134	200	7°	Composite
ES333-7CD	312902	333	7°	Composite

The installation of the transducer (or transducers) is not described in detail in this manual. Please refer to the documentation provided with each transducer.

Related topics

[Transducers, page 20](#)

[Additional required items, page 26](#)

Physical dimensions versus beam opening

The physical dimensions of a transducer can be explained as a function of the beam opening at a given operating frequency.

Traditionally, a 7° opening angle has been the standard for marine surveys. However, for applications where the physical size and weight of the transducer is important, you can reduce the size by allowing a larger opening angle of the acoustic beam.

The effective circular area of the transducer face is calculated from the equation:

$$A \cong \left(\frac{\lambda}{2\beta}\right)^2 \times \pi$$

Where:

- A =effective transducer circular area
- λ =wave length
- β =beam width in radians (-3 dB points)

The transducer near field is the region right in front of the transducer face, where the sound waves are complicated and does not fall off spherically with range. Targets within the near field will not be detected correctly. The near field is calculated by the equation:

$$\text{Near field} \cong \frac{A}{\lambda}$$

Parameters from typical scientific transducers are given in the table. The maximum and minimum source level (SL) is calculated from the available power settings on the Simrad EK80 scientific echo sounder.

Frequency	Wavelength	Beam width	Max/Min SL	Effective circular area	Near field
18 kHz	83 mm	11°	225/215 dB	1479 cm ²	178 cm
38 kHz	39 mm	7°	229/219 dB	820 cm ²	208 cm
70 kHz	21 mm	7°	227/217 dB	242 cm ²	113 cm
120 kHz	13 mm	7°	222/212 dB	82 cm ²	66 cm
200 kHz	8 mm	7°	220/212 dB	30 cm ²	39 cm
333 kHz	5 mm	7°	212/209 dB	11 cm ²	24 cm

Related topics

[Transducers, page 20](#)

Scope of supply

Topics

[Basic items provided with a standard delivery, page 25](#)

[Additional required items, page 26](#)

[Additional optional items, page 27](#)

Basic items provided with a standard delivery

To assemble a complete EK60 system, you will need a set of system units. The main units required are provided with the standard delivery. Other required units may be purchased from Kongsberg Maritime or obtained locally. Some units are optional.

When you unpack the items provided with the Simrad EK60 system, verify that the following items are included.

General Purpose Transceiver (GPT)

One or more General Purpose Transceiver (GPT) units are provided.

Single beam	Order number	In the box
GPT 12 kHz 2 kW 230 Vac	EK6-206809	Transceiver Unit Power supply with cables Software and documentation

Split beam	Order number	In the box
GPT 18 kHz 2 kW 115 Vac	EK6-203322	Transceiver Unit Power supply with cables Software and documentation
GPT 18 kHz 2 kW 230 Vac	305088	
GPT 38 kHz 2 kW 115 Vac	EK6-202589	
GPT 38 kHz 2 kW 230 Vac	304409	
GPT 70 kHz 1 kW	EK6-202590	Transceiver Unit Software and documentation
GPT 120 kHz 1 kW	EK6-202591	
GPT 200 kHz 1 kW	EK6-202592	
GPT 333 kHz 300W	314662	

Operational software

Operational software is provided on a suitable media. If the Processor Unit is purchased from Kongsberg Maritime, it is already installed.

End user documentation

End user documentation is provided on digital formats. All documentation related to operation and installation can also be downloaded from our website.

- <http://www.simrad.com/ek60>

Related topics

[General Purpose Transceiver \(GPT\) description, page 19](#)

[General Purpose Transceiver \(GPT\) outline dimensions, page 169](#)

[GPT Power supply outline dimensions, page 172](#)

Additional required items

The EK60 delivery will contain the mains parts required for basic operation. Certain required items must be added to the EK60 for full operational functionality. Some of these can be ordered from Simrad, others may be purchased locally.

Computer

The Simrad EK60 system is designed to be controlled by a maritime computer. This computer must be based on the Microsoft Windows® 7 operating system. It must further be designed for rugged use, and should be able to withstand the vibrations and movements of a vessel.

The computer must comply to the requirement specifications provided by Microsoft for their operating systems. It must also provide the necessary interface facilities (serial lines and Ethernet connections) that your EK60 will need to communicate with peripheral systems.

A suitable computer may be provided with the EK60 system.

Consult your dealer or agent for more information.

Product	Order number	In the box
<i>Enix</i> computer	386927	Software (readily installed) Power cable Serial line adapter

Transducer(s)

A large range of transducers is available for the different operational frequencies. For order numbers, see the Simrad website.

Display

Any commercial display can be used with the EK60 Scientific Echo Sounder, provided that the display meets the minimum requirements. If you intend to use many views simultaneously, we suggest that you purchase a large high-resolution display.

Ethernet switch

If you use more than one transceiver, an Ethernet switch is required.

Product	Order number	In the box
Black Box LBS209AE-R2	352527	Ethernet switch Power supply

Related topics

[Processor Unit description, page 18](#)

[Ethernet switch, page 19](#)

[Split beam transducers, page 21](#)

[Wideband transducers, page 22](#)

[Depth rated transducers, page 22](#)

[Processor Unit outline dimensions, page 175](#)

[Minimum technical requirements for display, page 190](#)

[Minimum computer requirements, page 189](#)

Additional optional items

The EK60 delivery will contain the mains parts required for basic operation. Several optional items are also available. Some may be ordered from Simrad, others may be purchased locally. These optional items are not required for normal use, but may offer advantages related to installation, maintenance, or operational functionality.

Uninterrupted Power Supply (UPS)

In order to ensure continuous operation of the EK60 independent of varying quality of the vessel's mains supply, the use of uninterruptible power supplies is recommended.

Normally, a single uninterruptible power supply unit is enough to power the EK60system. An existing supply can also be used.

General safety rules

The following safety precautions must be followed at all times during installation and maintenance work.

WARNING

The Simrad EK60 operates on 230 Vac 50/60 Hz. This voltage is lethal!

- You must always switch off all power before installation or maintenance work on the EK60 system.
Use the main circuit breaker, and label the breaker with a warning sign that informs others that maintenance or installation work is in progress on the system.
- For safety reasons, two persons must always be present during troubleshooting with power ON.
- Read and understand the applicable first aid instructions related to electric shock.
- Whenever maintenance is in progress, it is essential that a first aid kit is available, and that all personnel are familiar with the first aid instructions for electrical shock.

Installation requirements

Topics

[Supply power requirements, page 29](#)

[Uninterrupted Power Supply \(UPS\) requirements, page 29](#)

[Basic wiring requirements, page 29](#)

[Compass deviation requirements, page 30](#)

[Noise sources, page 30](#)

[Dry docking requirements, page 30](#)

[Classification approval requirements, page 30](#)

Supply power requirements

Observe the general requirements related to the supply power.

The supply voltage to the equipment is to be kept within $\pm 10\%$ of the installation's nominal voltage. Maximum transient voltage variations on the main switchboard's bus-bars are not to exceed -15% to $+20\%$ of the nominal voltage (except under fault conditions).

Uninterrupted Power Supply (UPS) requirements

Observe these requirements related to an Uninterrupted Power Supply (UPS).

We recommend that the EK60 system is powered using an Uninterrupted Power Supply (UPS) with sine wave output.

The Uninterrupted Power Supply must have the capacity to independently maintain power to the system for a minimum of 10 minutes. This ensures that the EK60 can be switched off in a controlled manner in the event of a power failure.

Basic wiring requirements

Correct wiring is crucial for the operational performance of the EK60.

All cables running between system cabinets located in different rooms and/or on different decks must be supported and protected along their entire lengths using conduits and/or cable trays. Note that the cables must not be installed in the vicinity of high-power supplies and cables, antenna cables or other possible sources of interference.

All transducer cables must be run in steel conduits.

For more detailed information about cables and wiring, refer to the basic cable requirements.

Compass deviation requirements

EK60 system units that are installed on the bridge may have an effect on the compass.

Once the installation is complete, the vessel must be swung with the EK60 system in both operative and inoperative modes. The shipowner and captain are responsible for updating the compass deviation table accordingly with regard to the vessel's national registry and corresponding maritime authority.

Noise sources

The operational performance of all hydroacoustic systems depend on the noise conditions.

The vessel's hull, rudder(s) and propeller(s) must be thoroughly inspected in dry dock prior to installation.

Roughness below the water-line deformities in the shell plating and protruding obstacles can create underwater noise. These sources of turbulence must be smoothed or removed as best as possible. It is especially important that the propeller(s) are not pitted or damaged.

Dry docking requirements

Whenever devices for hydroacoustic use are mounted under the vessel's hull, special considerations must be made prior to dry docking.

Make sure that ample clearance under the transducer(s) and/or protection blister is provided when dry docking the vessel.

Avoid locating supporting blocks or structures in the vicinity of this equipment.

Prior to dry docking, power down all hydro-acoustic systems on the vessel, and label each system accordingly to prevent anyone from powering up the system(s) accidentally. Remove circuit breakers if necessary.

Classification approval requirements

Classification approval is required for the EK60 installation.

The EK60 transducer installation must be approved by Det Norske Veritas (DNV) or another national classification society.

The shipowner and shipyard performing the installation are responsible for obtaining this installation approval.

Network security

If a EK60 system is connected to the ship's local area network, data security is of vital importance.

Equipment manufactured by Kongsberg Maritime are frequently connected to the ship's local area network (LAN). Connecting any computer to a network will always expose the data on that computer to all other computers connected to the same network. Several threats may immediately occur:

- Remote computers can read the data.
- Remote computers can change the data.
- Remote computers can change the behaviour of the computer, for example by installing unwanted software.

Usually, two parameters are used to define the threat level:

- 1 The likelihood that any remote connection will do any of the above.
- 2 The damage done if a remote connection succeeds doing this.

Because Kongsberg Maritime has no information regarding the complete system installation on any vessel, we can not estimate the threat level and the need for network security. For this reason, we can not accept responsibility for network security. Systems provided by Kongsberg Maritime are regarded as stand-alone offline systems, even though they may be connected to a network for sensor interfaces and/or data distribution.

Note

No network safety applications are installed on any Kongsberg Maritime computers. The computers are thus not protected against viruses, malware or unintentional access from external users.

Securing the EK60 system itself has no meaning unless there is a policy in place that secures all computers in the network. This policy must include physical access by trained and trusted users. The customer/end user of the EK60 system will always be in charge of defining and implementing a security policy, and providing the relevant network security applications.

Note

Kongsberg Maritime will not accept any responsibility for errors and/or damages caused by unauthorized use or access to the EK60.

Related topics

[Important, page 12](#)

Support information

If you need technical support for your Simrad EK60 you must contact your local dealer, or one of our support departments. A list of all our offices and dealers is provided on our website. You can also contact our main support office in Norway.

Norway (Main office)

- **Company name:** Kongsberg Maritime AS / Simrad
- **Address:** Strandpromenaden 50, 3190 Horten, Norway
- **Telephone:** +47 33 03 40 00
- **Telefax:** +47 33 04 29 87
- **Website:** <http://www.simrad.no>
- **E-mail address:** simrad.support@simrad.com

France

- **Company name:** Simrad France
- **Address:** 2 Rue Saint Jacques, 29730, Treffiagat, France
- **Telephone:** +33 298 582 388
- **Telefax:** +33 298 582 381
- **Website:** <http://www.simrad.fr>
- **E-mail address:** simrad.france@simrad.com

Spain

- **Company name:** Simrad Spain
- **Address:** Poligono Partida Torres 38, 03570 Villajoyosa, Spain
- **Telephone:** +34 966 810 149
- **Telefax:** +34 966 852 304
- **Website:** <http://www.simrad.es>
- **E-mail address:** simrad.spain@simrad.com

USA

- **Company name:** Kongsberg Underwater Technology Inc / Simrad Fisheries
- **Address:** 19210 33rd Ave W, Lynnwood, WA 98036, USA
- **Telephone:** +1 425 712 1136
- **Telefax:** +1 425 712 1193
- **Website:** <http://www.simrad.com>
- **E-mail address:** fish.usa.support@simrad.com

Malaysia

- **Company name:** Kongsberg Maritime Malaysia Sdn. Bhd
- **Address:** Unit 27-5 Signature Offices, The Boulevard, Mid Valley City, Lingkaran Syed Putra, 59200 Kuala Lumpur, Malaysia
- **Telephone:** +65 6411 7488
- **Telefax:** +60 3 2201 3359
- **Website:** <http://www.simrad.com>
- **E-mail address:** simrad.asia@simrad.com

Related topics

[Important, page 12](#)

Preparations

Topics

[Installation summary, page 35](#)

[About installation drawings, page 36](#)

[Necessary tools and equipment for EK60 installation, page 37](#)

[Requirements for shipyard worker skills, page 37](#)

[Where to install the transducer, page 38](#)

[Acoustic noise, page 41](#)

Installation summary

Installation of the EK60 is a demanding task that requires careful preparations, a number of specific procedures, wiring and required system settings.

Context

An overall installation procedure is provided below. The procedure does not describe any detailed tasks, but refers to the relevant procedures in this manual.

Note

In order to obtain maximum safety and performance, it is very important that the installation procedures in this manual are complied to, and that the tasks are carried out in the succession they are described. The vessel owner must make sure that the installation shipyard holds the applicable competence to perform the installation, and that the applicable maritime authorities are available to verify and certify the installation.

Procedure

- 1 Based on the vessel drawings and best practice, determine where the transducer (or transducers) shall be located.

Necessary considerations must be taken to avoid acoustic and electric disturbances.

Note

This information in this document must be regarded as general guidelines and recommendations only.

The installation shipyard must design and manufacture installation hardware to fit the transducer to each individual vessel.

Whenever required, the installation shipyard must also have the installation approved by the applicable maritime authorities.

- 2 Install each transducer.

The installation shipyard must provide all necessary drawings in order to do this installation, and if required, these drawings must be approved by the applicable maritime authorities. Each transducer will penetrate the hull, and this is therefore a crucial part of the EK60 installation.

Relevant installation drawings are included with each transducer. Drawings can also be downloaded from our website:

- <http://www.simrad.com>

- 3 Install the EK60 system units.

Note that some EK60 system units may be commercial. Unless ordered specifically these are not included in the delivery, and must be purchased locally.

- 4 Install the cables between the EK60 system units.

Observe the relevant cable plan, procedures, as well as the general requirements for cabling.

- 5 Power up the EK60 for the first time, and set it to work.

Note

In order to set up the EK60 in a safe and correct manner, these procedures must be complied to!

- 6 Connect the peripheral units.

- 7 Run a complete system test.

The tests are described in *Setting to work* chapter in this manual, as well as in the *Harbour Acceptance Test* and the *Sea Acceptance Test* documents.

Further requirements

Fill in and sign the *Installation Remarks* form, and send it to Simrad's support department as specified on the form.

About installation drawings

All installation drawings must be supplied by the shipyard performing the installation.

Note

If required, all drawings provided by the shipyard for the physical installation of the EK60 must be approved by the vessel's national registry and corresponding maritime authority and/or classification society. Such approval must be obtained before the installation can begin. The shipowner and shipyard doing the installation are responsible for obtaining and paying for such approval.

Simrad offers free advice for installation planning. Proposed arrangements may be sent for commentary or suggestions. The following drawings should be submitted should assistance be requested:

- General arrangement
- Body plan and drawings of the relevant compartment
- Lines plan

Relevant outline dimensions and production drawings can be download from our website. Most documents are available in PDF or AutoCad (DWG) formats.

- <http://www.simrad.com/ek60>

Necessary tools and equipment for EK60 installation

The installation of the EK60 must take place in dry dock, and the work must be done by a qualified shipyard.

In order to do the EK60 installation, all necessary tools and equipment for mechanical hull work, cabinet installation and electrical wiring must be available. It is not practical to provide a detailed list of all necessary tools and equipment. However, you must make sure that the following specialized tools are available.

- All necessary tools and items required for welding
- All necessary tools and consumables required for physical installation of units, cabinets and racks
- All necessary tools and items required for electrical installations

Note _____

Whenever specific consumables or special tools or test instruments are required, these are identified in the relevant procedure(s).

Requirements for shipyard worker skills

The installation of the EK60 is a demanding task. It is very important that the shipyard workers involved in the installation tasks are competent.

As a minimum, the following certified craftsmen must be available:

- naval architects
- welders
- electricians
- project manager

Note _____

The quality of the welding is critical to the safety of the vessel. Welding must only be done by a certified welder.

The final installation work must be approved by the vessel's national registry, the corresponding maritime authority and/or classification society. The shipowner and shipyard doing the installation are responsible for obtaining and paying for such approval.

Where to install the transducer

Topics

[Introduction, page 38](#)

[Mount the transducer deep, page 38](#)

[Avoid protruding objects, page 39](#)

[Stay far away from the propellers, page 39](#)

[Choose a position far away from the bow thruster\(s\), page 39](#)

[Summary and general recommendations, page 40](#)

Introduction

A single answer to the question “where to install the transducer” cannot be given.

The physical location of the transducer depends on the vessel's design and construction, how the hull is shaped, and how the water runs along the hull. There are however a number of important guidelines, and some of these are even conflicting.

Note

The information here must be considered as general advice. Each EK60 installation must be handled separately depending on the hull design.

Mount the transducer deep

In order to achieve the best possible EK60 performance, mount the transducer as deep as possible under the vessel's hull.

Consider the situations when the vessel is unloaded, and when it is pitching in heavy seas.

There are several reasons for this.

- 1 The upper water layers of the sea contain a myriad of small air bubbles created by the breaking waves.

In heavy seas the upper 5 to 10 metres may be filled with air, and the highest concentrations will be near the surface. Air bubbles absorb and reflect the sound energy, and they may in worst cases block the sound transmission altogether.

- 2 Another reason to go deep is cavitation.

Cavitation is the formation of small bubbles in the water close to the transducer face due to the resulting local pressure becoming negative during parts of the acoustic pressure cycles. The cavitation threshold increases with the hydrostatic pressure.

- 3 The transducer must never be lifted free of the water surface.
Transmitting into open air may damage the it beyond repair. Mounting the transducer at a deep position on the hull will in most cases prevent this.
- 4 If the transducer is lifted up from the water during heavy seas, it may be damaged when the hull strikes back at the sea surface.
This is especially important for low frequency transducers with large faces.

Avoid protruding objects

Objects protruding from the hull will generate turbulence and flow noise. This will reduce the EK60 performance.

Such objects may be zinc anodes, sonar transducers or even the vessel's keel. Holes and pipe outlets are also important noise sources, as well as rough surfaces caused by bad welding. All these protruding objects may act as resonant cavities amplifying the flow noise at certain frequencies.

Do not place a transducer in the vicinity of such objects, and especially not close behind them. For the same reason, it is very important that the hull area around the transducer face is as smooth and level as possible.

Even traces of sealing compound, sharp edges, protruding bolts or bolt holes without filling compound will create noise.

Stay far away from the propellers

The propulsion propellers is the dominant noise source on most vessels. The noise is transmitted through the sea water, and may often reduce the performance of your EK60 system.

For this reason, the transducer must be placed far away from the propellers, which means on the fore part of the hull. Positions outside the direct line of sight from the propellers are favourable.

On small vessels with short distances it is advised to mount the transducer on that side of the keel where the propeller blades move upwards, because the propeller cavitation is strongest on the other side. The cavitation starts most easily when the water flows in the same direction as the propeller blade, and that is to some degree the case at that side of the keel where the propeller blades move downwards.

Choose a position far away from the bow thruster(s)

Bow thruster propellers are extremely noisy.

When in operation, the noise and cavitation bubbles created by the thruster may make your EK60 system useless, almost no matter where the transducer is installed.

And when not in operation, the tunnel creates turbulence. If your vessel is pitching, the tunnel may be filled with air or aerated water in the upper position and release this in the lower position.

In general, all transducers must therefore be placed well away from the bow thruster. In most cases, a location forward of the bow thruster is advantageous.

However, this is not an invariable rule. Certain thruster designs combined with its physical location on the hull may still offer suitable locations near the thruster. If you are in doubt, consult a naval architect.

Summary and general recommendations

Some of the installation guidelines provided for transducers may be conflicting. For this reason, each vessel must be treated individually in order to find the best compromise.

In general, the most important factor is to avoid air bubbles in front of the transducer face. For this reason, the recommended transducer location is normally in the fore part of the hull, well ahead of the noise created by the bow wave. The maximum distance from the bow is normally equal to one third of the total water line length of the hull.

If the vessel hull has a bulbous bow, this may well be a good transducer location, but also in this case the flow pattern of the aerated water must be taken into consideration. Often the foremost part of the bulb is preferable.

This applies to the vessel in normal trim and speed.

Important

Under no circumstances should the transducer be tilted backwards when the vessel is moving at an appreciable speed. Mounting screws must never be extruding from the transducer, and the space around the screws must be filled with a compound or a locking ring.

Acoustic noise

As with any other hydroacoustic systems, the quality of the EK60 presentations are subject to unwanted acoustic noise. The echoes from any large and small target must be detected inside the noise.

It is important that we keep this noise level as low as possible in order to obtain long range and dependable interpretations of the echoes. Even with the advanced noise filtering offered by the EK60, we must address the noise challenge during both planning and preparations for the EK60 installation.

Topics

[Contributing factors, page 41](#)

[Self noise, page 43](#)

[Ambient noise, page 45](#)

[Fishing gear noise, page 45](#)

[Electrical noise, page 46](#)

[Some means to reduce acoustic noise, page 46](#)

Contributing factors

Several factors are contributing to the performance of the hydroacoustic equipment used on board a vessel.

Such factors include:

- The quality and properties of the transmitted signal
- The quality of the receiving system
- The operational settings made during operation
- The properties of the target(s)
- The signal-to-noise ratio

The majority of these factors can neither be controlled nor improved by means of installation methods or transducer locations. The quality and properties of the transmitting and receiving systems are key factors during our product development, while our end user documentation aims to help the user to make the right filter settings during operation. As for the target properties, there is nothing any of us can do with those.

The *signal-to-noise ratio*, however, can be improved by making the correct choices during installation.

Signal-to-noise ratio (often abbreviated SNR or S/N) is a measure used in science and engineering that compares the level of a desired signal to the level of background noise. It is defined as the ratio of signal power to the noise power, often expressed in decibels. A ratio higher than 1:1 (greater than 0 dB) indicates more

signal than noise. While SNR is commonly quoted for electrical signals, it can be applied to any form of signal [...].

http://en.wikipedia.org/wiki/Signal_to_noise_ratio (September 2013)

For active sonar and echo sounder systems, the signal is the echo that we want to know something about, while the noise is any unwanted signals or disturbances. The echo must be detected in the noise and therefore it is necessary to keep the noise level as low as possible in order to obtain long range and dependable interpretation. The noise that contributes to the signal to noise ratio on hydroacoustic instruments may be divided into the following types of noise:

- Self noise
- Ambient noise
- Fishing gear noise
- Electrical noise
- Reverberation

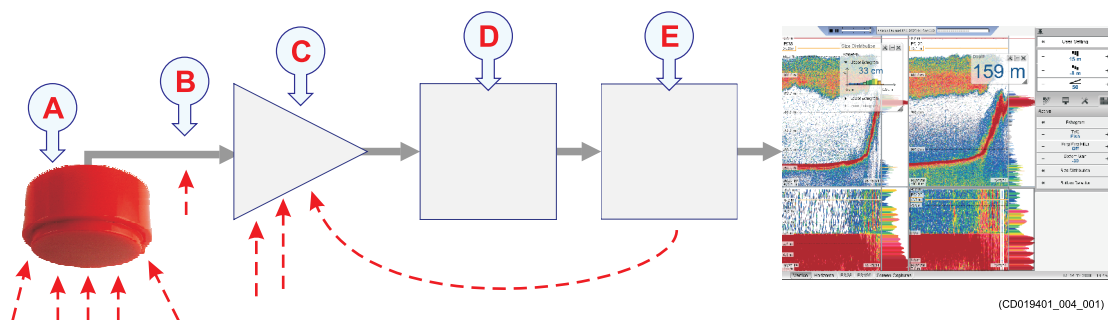

- A** The transducer can pick up noise from
 - Biological disturbances
 - Interference
 - Cavitation
 - Propeller noise
 - Flow noise
 - Acoustic noise from other hydroacoustic systems
- B** The transducer cable is long, and may pick up electric noise from generators, pumps, cooling systems etc.
- C** The preamplifiers are very sensitive, and they can easily pick up electrical noise from internal and external power supplies. They are also vulnerable for analogue noise created by their own circuitry. Digital noise created by the converter and processing circuitry can also create problems.
- D** A/D converters transform the analogue echoes to digital format.
- E** Signal processing circuitry can create digital noise.

Self noise

Any vessel equipped with a hydroacoustic system will produce more or less self noise.

There are many sources of such self noise.

- **Machinery noise:** Main engine, auxiliary engines, gears, pumps, blowers, refrigerator systems, etc.
- **Electric noise:** Electric motors, ground loops, etc
- **Propeller noise:** Propeller blade properties, cavitation, shaft vibrations, static discharges
- **Cavitation**
- **Flow noise:** Laminar flow, turbulent flow, bubbles, etc
- **Rattle noise:** Loose parts
- **Interferences:** Other hydroacoustic systems on your own vessel

We will here go into some details in order to analyse the different sources of self noise on a vessel and how they may influence upon the noise level of the hydroacoustic instruments.

Machinery noise

The main contributor is usually the main engine on board the vessel. The contribution from auxiliary machinery may, however, be considerable, especially if some of it is in poor shape. The machinery noise can be transmitted to the transducer as a:

- Structure-borne noise through the ship structure and the transducer mountings
- Water-borne noise through the hull into the water to the transducer

Electric noise

Modern vessels are normally equipped with a lot of electric instruments such as hydroacoustic systems, radars, navigation systems, and communication equipment. Any electric instruments may in some cause electrical interference and noise.

International regulations and certifications are used to control and reduce this, but even these are limited if the electrical systems are poorly installed and maintained.

Propeller noise

This source is often the main source of noise at higher vessel speeds. Variable pitch propellers or fast moving propellers usually make more noise than fixed propellers or slow moving propellers.

This noise is usually water-borne. In some cases, however, shaft vibrations or vibrations in the hull near the propeller may be structure-borne to the transducer. If a propeller blade is damaged, this may increase the noise considerably.

Propeller cavitation is a severe source of noise. "Singing" propellers might be a source of noise, which interferes at discrete frequencies. In some cases static discharge from the rotating propeller shaft may be quite disturbing.

Cavitation

Cavitation usually occurs more willingly in air filled water and the occurrence is dependent on the hydrostatic pressure. Cavitation is a severe source of noise. The noise is made when the voids implode. Cavitation noise often occurs at the propeller and near extruding objects at higher speeds.



Contributions to the flow noise may also be caused by air bubbles hitting the transducer face, or by the splash caused by the waves set up by the vessel. In some cases a resonant phenomenon is set up in a hole near the hull. This sound will have a discrete frequency, while all other flow noise will have a wide frequency spectrum.

(Image from U. S. Navy in the public domain.)

Flow noise

Every object that moves through water will disturb the medium, and it will cause friction in the water. The friction zone is called the *flow boundary layer*. The flow in this boundary layer may be *laminar* or *turbulent*.

- The laminar flow is a nicely ordered, parallel movement of the water.
- The turbulent flow is a disorderly flow pattern, full of eddies.

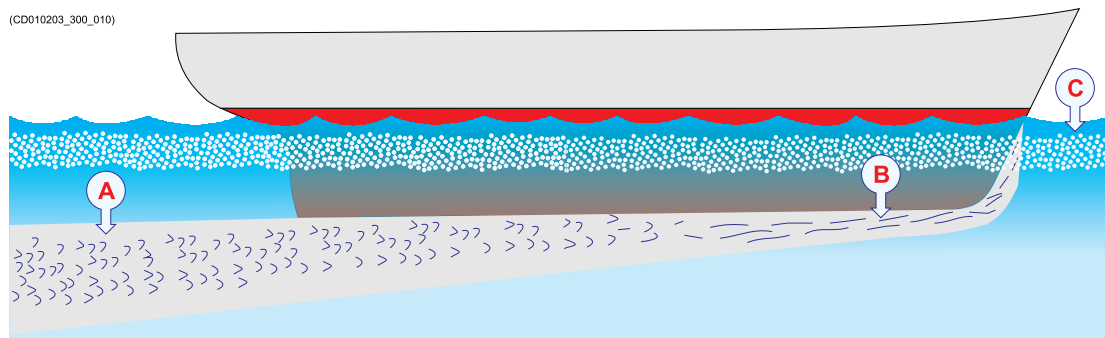

- A *Turbulent flow*
- B *Laminar flow*
- C *Air bubbles*

The boundary layer increases in thickness when it becomes turbulent. The boundary layer is thin in the forward part of the vessel hull, and increases as it moves aft. The thickness depends on ships speed and on the roughness of the hull. All objects sticking out from the hull, or dents in the hull, will disturb the flow and will increase the thickness of the boundary layer. When the flow speed is high, the turbulence can be violent enough

to destroy the integrity of the water. Small voids or cavities in the water will occur and this is called cavitation.

Rattle noises

Rattle noise may be caused by loose objects in the vicinity of the transducer, like fixing bolts. The rattle may also come from loose objects inside the hull.

Interference

Interference from other hydroacoustic equipment on board the same vessel may be an annoying source of disturbance. Unless the same frequency is used for more than one piece of equipment only the transmitted pulse will contribute to the interference.

Ambient noise

Ambient noise is usually not a limiting factor to the performance of sonars and echo sounders.

The ambient noise may be split up as follows:

- **Sea noise:** Air bubbles, seismic disturbances, waves, boundary turbulence, etc.
- **Biological noise:** Fish, mammals, etc.
- **Man made noise:** Other vessels, interference
- **Precipitation noise**

In some areas, where many vessels are operating together the engine and propeller noise from other vessels might be disturbing.

Interference from hydroacoustic instruments located in other vessels may also be a limiting factor.

The sea noise is as can be expected dependent on the weather conditions. In bad weather the sea noise can be quite high.

Fishing gear noise

Whenever your fishing gear is in use, it will create noise.

A bottom trawl, for instance, is a considerable noise maker.

Still, this noise will seldom be a limiting factor for hull mounted sonars or echo sounders.

However, for operation of a catch monitoring system or a trawl sonar, with the transducer(s) placed on the trawl, the gear noise is one of the main contributors to the noise level.

Electrical noise

Electrical or electronic noise is picked up or generated in any other part of the equipment than the transducer.

Hum picked up by the transducer cables or picked up from the voltage supply is usually the most common source of electrical noise.

At higher frequencies – where rather wide bandwidths are necessary – the noise from components, transistors or other analogue electronic may be a limiting factor.

Some means to reduce acoustic noise

Careful planning of the EK60 installation may reduce the acoustic noise.

Unfortunately, it is impossible to simply provide a number of specific procedures to reduce the noise.

An important factor is the physical location of the transducer. This depends on the vessel's design and construction, how the hull is shaped, and how the water runs along the hull.

Other factors deal with other equipment mounted on board, and this will also be vessel dependant.

At moderate ship speeds the machinery noise is usually dominant. At medium speeds the flow noise increases more rapidly and takes over, while at higher speed the propeller noise will be the main contributor.

Note

The information here must be considered as general advice. Each EK60 installation must be handled separately depending on the hull design and the other electrical and mechanical systems installed on the vessel.

Reducing flow noise

- The shape of the transducer (or dome around it) must be as streamlined as possible.
- The hull plating in front of the transducer must be as smooth as possible. Be especially aware of bilge keels and zinc alloy anodes. The keel should be rounded off without sharp edges.

Important

No extruding objects or any abrupt transitions should appear.

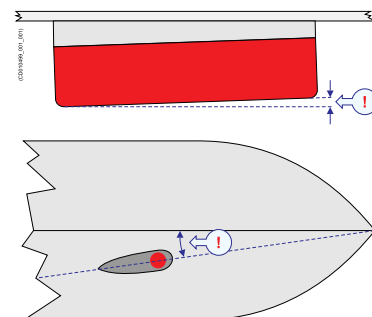

- Echo sounder transducer should be mounted with a small inclination angle (approximately 2 degrees).

Reducing machinery noise

- The transducer(s) must be installed as far away from the engine room as possible.
- The main engine and relevant auxiliary engines and equipment should be fixed to rigid foundations to avoid vibrations. Use of shock absorbers or floating rafts may sometimes reduce this noise.
- Any hull structure that may vibrate should be damped or coated to reduce the vibrations.
- The structure-borne noise may be reduced by isolation, for example by providing vibration clamping between the transducer and the hull structure.

Reducing propeller noise

- The transducer should be installed as far away from the propellers as possible.
- Sufficient clearance between the propellers and the hull, the rudder and the keel should be provided.
- Place the zinc alloy anodes in places where the water flow is the least disturbed.
- Ensure that the propellers blades are correctly designed and without damages.
- The use of a baffle between the propellers and the transducer may reduce noise appreciably.
- Static discharges caused by the rotating propeller shaft may be removed by proper grounding or by mounting a coal brush from the shaft to ground.

Reducing rattle noise

Ensure that no parts near the transducer can rattle as a result of water flow or vibrations.

Reducing interference

Interference from the transmission pulses from other hydroacoustic instruments on board the vessel is difficult to avoid.

The problem may be reduced by choosing the working frequencies carefully and to some extent by separating the different transducers.

On vessels with a large number of separate hydroacoustic systems installed and in simultaneous use, a separate synchronizing system (for example the **K-Sync**) should be considered.

Reducing electrical noise

- Place the transducer cables in metal conduits from as close to the transducer as possible, and all the way to the rear side of the transceiver.

- Make sure that all units are properly grounded, as this is important to avoid electrical noise.
- You must use shielded cables with correct grounding.
- Separate EK60 cables from other cables with heavy currents or transients.
- Place all high voltage power cables in metal conduits.

Installing the EK60 hardware units

Topics

[Installing the General Purpose Transceiver \(GPT\), page 50](#)

[Installing the General Purpose Transceiver \(GPT\) power supply, page 51](#)

[Installing the display, page 53](#)

[Installing a commercial computer, page 54](#)

[Installing the Enix Processor Unit, page 55](#)

[Installing the transducer\(s\), page 58](#)

Installing the General Purpose Transceiver (GPT)

A specific installation procedure is provided for the General Purpose Transceiver (GPT).

Prerequisites

A suitable location for the General Purpose Transceiver (GPT) must be defined prior to installation. The unit can in principle be mounted anywhere on board the ship, provided that the location is dry and ventilated. We recommend that it is mounted as close to the transducer(s) as possible.

Context

The General Purpose Transceiver can be installed in several different ways using the mounting hardware provided with the unit.



Two brackets and four pan head screws are enclosed. The side walls of the unit each hold six screws; three screws along the bottom edge and three screws along the top edge. The brackets can be vertically mounted in three different positions;

- Use the two rear holes, *or*
- Use the two centre holes, *or*
- Use the two front holes.

The brackets can be horizontally mounted in four different ways using either the bottom edge holes or the top edge holes. The brackets can be horizontally mounted in four different ways using either the bottom edge holes or the top edge holes.

Procedure

- 1 Prepare the location and the necessary tools.
- 2 Observe the installation requirements.
 - a Depending on the local requirements and preferences, the General Purpose Transceiver (GPT) can be installed on the bulkhead, inside a console, in a cabinet or 19" rack, or on a desk.
 - b The position must be chosen to fit the available cable lengths between the transceiver and the other units it connects to. Short distance to the transducer(s) is always first priority.
 - c Observe the compass safe distance.
 - d Make sure that enough space is made available for maintenance purposes.
 - e Make sure that adequate ventilation is available to avoid overheating.
 - f Ensure that the installation method allows for the physical vibration, movements and forces normally experienced on a vessel.

Note

In order to allow for future maintenance, we strongly advise that you mount the unit with its cables and connectors available for immediate access.

- 3 Verify that the chosen location meets the requirements.
- 4 Unscrew two screws from each side wall.
- 5 Mount the brackets using the pan head screws.
- 6 Position the unit on the surface and mark the four mounting holes.
- 7 Remove the unit, and drill mounting holes.
- 8 Mount the General Purpose Transceiver (GPT) using the appropriate brackets.
- 9 Mount the unit to the surface using 5 mm bolts.
- 10 Connect the cables.

Note

When you connect the cables, make sure that they are all properly secured, and able to withstand the vibration and movements of the vessel.

Related topics

[General Purpose Transceiver \(GPT\) outline dimensions, page 169](#)

[GPT Power supply outline dimensions, page 172](#)

Installing the General Purpose Transceiver (GPT) power supply

The power supply provided with the General Purpose Transceiver (GPT) is a commercial type. A specific installation procedure is provided.

Prerequisites

A suitable location for the power supply must be defined prior to installation.

Note

If you place the unit on the bridge, observe the compass safe distance.

You must be equipped with a standard set of tools. This tool set must comprise the normal tools for electronic and electromechanical tasks, such as screwdrivers, pliers, spanners, a cable stripper etc. Each tool must be provided in various sizes. We recommend that all tools are demagnetized to protect your equipment.

Context

The power supply provided with the General Purpose Transceiver (GPT) can be installed in many ways. Observe the outline dimensions drawing.

- Desktop mounting using the brackets provided with the power supply.
- Wall/bulkhead mounting using the using the brackets provided with the power supply.

For special purposes, ad-hoc installation using any means available is also a possibility.

Procedure

- 1 Prepare the location and the necessary tools.
- 2 Observe the installation requirements.
 - a The position must be chosen to fit the available cable lengths between the power supply, the transceiver and the AC power outlet.
 - b If you place the unit on the bridge, observe the compass safe distance.
 - c Make sure that enough space is made available for maintenance purposes.
 - d Make sure that adequate ventilation is available to avoid overheating.
 - e Ensure that the installation method allows for the physical vibration, movements and forces normally experienced on a vessel.

Note

In order to allow for future maintenance, we strongly advice that you mount the unit with its cables and connectors available for immediate access.

- 3 Verify that the chosen location meets the requirements.
- 4 Mount the power supply using suitable bolts or screws.
- 5 Connect the cables.

Note

When you connect the cables, make sure that they are all properly secured, and able to withstand the vibration and movements of the vessel.

Installing the display

The display is normally not included with the EK60 delivery. A generic procedure is therefore provided.

We assume that you are equipped with a standard set of tools. This tool set must comprise the normal tools for electronic and electromechanical tasks, such as screwdrivers, pliers, spanners, a cable stripper etc. Each tool must be provided in various sizes. We recommend that all tools are demagnetized to protect your equipment.

A suitable location for the display must be defined prior to installation.

Note

Observe the compass safe distance.

Procedure

- 1 Prepare the location and the necessary tools.
- 2 Observe the installation requirements.
 - a The display must be located so that it is best protected from glare which reduces readability.
 - b The display may be mounted in a panel, on the desktop or bulkhead, or overhead.
 - c Make sure that adequate ventilation is available to avoid overheating.
 - d Make sure that the installation allows for the physical vibration, movements and forces normally experienced on a vessel.
 - e Make sure that enough space is provided for maintenance work.
- 3 Install the display as described in the applicable documentation provided by the manufacturer.
- 4 Connect the cables.

Note

When you connect the cables, make sure that they are all properly secured, and able to withstand the vibration and movements of the vessel.

Installing a commercial computer

The Processor Unit (computer) may not be included with the EK60 delivery. A generic procedure is therefore provided.

Prerequisites

We assume that you are equipped with a standard set of tools. This tool set must comprise the normal tools for electronic and electromechanical tasks, such as screwdrivers, pliers, spanners, a cable stripper etc. Each tool must be provided in various sizes. We recommend that all tools are demagnetized to protect your equipment.

A suitable location for the computer must be defined prior to installation.

Note

If you place the unit on the bridge, observe the compass safe distance.

Context

For installation of a commercial computer, refer to the manual supplied by the manufacturer.

Procedure

- 1 Prepare the location and the necessary tools.
- 2 Observe the installation requirements.
 - a Depending on its physical properties, the computer can be installed inside a console, in a cabinet or 19" rack, or on a desk.
 - b The position must be chosen to fit the available cable lengths between the computer and the other units it connects to.
 - c Observe the compass safe distance.
 - d Make sure that enough space is made available for maintenance purposes.
 - e Make sure that adequate ventilation is available to avoid overheating.
 - f Ensure that the installation method allows for the physical vibration, movements and forces normally experienced on a vessel.

Note

In order to allow for future maintenance, we strongly advice that you mount the unit with its cables and connectors available for immediate access.

- 3 Verify that the chosen location meets the requirements.

- 4 Provide ample space around the computer.

You must be able to reach and use the front and rear mounted USB connectors, CD or DVD players, or to replaceable hard disks.

It is also important that you allow for easy access to all the cables, and enough space for inspection, maintenance and parts replacement.

If relevant, make sure that the space allows you to open the computer for unobstructed access to its internal parts.

Important _____

Make sure that you can access both the rear and front side of the computer after it has been installed.

- 5 Install the computer as described in the applicable documentation provided with the unit.

Note _____

Standard office computers may not be well fitted for maritime use. The motions and vibrations experienced on a vessel may reduce the computer lifetime considerably. During installation of a commercial computer, use your common sense to improve the installation method suggested by the manufacturer.

- 6 Connect the cables.

Note _____

When you connect the cables, make sure that they are all properly secured, and able to withstand the vibration and movements of the vessel.

Installing the Enix Processor Unit

A specific installation procedure is provided for the Processor Unit (computer).

Prerequisites

We assume that you are equipped with a standard set of tools. This tool set must comprise the normal tools for electronic and electromechanical tasks, such as screwdrivers, pliers, spanners, a cable stripper etc. Each tool must be provided in various sizes. We recommend that all tools are demagnetized to protect your equipment.

A suitable location for the computer must be defined prior to installation.

Note _____

If you place the unit on the bridge, observe the compass safe distance.

- A** *The bottom plate is mounted with six bolts through the computer chassis.*
- B** *Each rail provides two holes for mounting to a flat surface.*
- C** *Remove this bolt to release the rail from the bottom plate.*

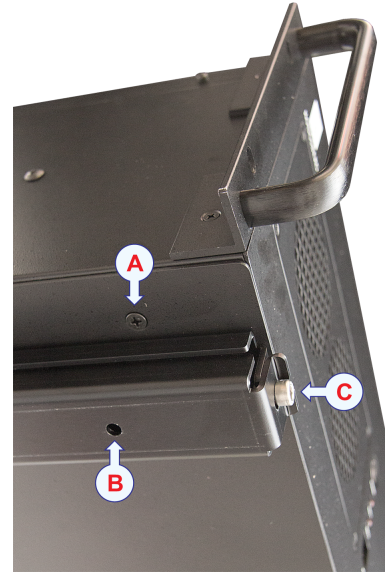

Context

If you intend to mount the Enix Processor Unit in a 19" rack, you can disregard this procedure. However, you may then wish to remove the bottom plate and shock absorbers as described in this procedure, as these will not be required.

Procedure

- 1 Prepare the location and the necessary tools.
- 2 Observe the installation requirements.
 - a Depending on its physical properties, the computer can be installed inside a console, in a cabinet or 19" rack, or on a desk.
 - b The position must be chosen to fit the available cable lengths between the computer and the other units it connects to.
 - c Observe the compass safe distance.
 - d Make sure that enough space is made available for maintenance purposes.
 - e Make sure that adequate ventilation is available to avoid overheating.
 - f Ensure that the installation method allows for the physical vibration, movements and forces normally experienced on a vessel.

Note

In order to allow for future maintenance, we strongly advice that you mount the unit with its cables and connectors available for immediate access.

- 3 Verify that the chosen location meets the requirements.

- 4 Provide ample space around the Processor Unit.

You must be able to reach and use the front and rear mounted USB connectors, CD or DVD players, or to replaceable hard disks.

It is also important that you allow for easy access to all the cables, and enough space for inspection, maintenance and parts replacement.

If relevant, make sure that the space allows you to open the computer for unobstructed access to its internal parts.

Important _____

Make sure that you can access both the rear and front side of the computer after it has been installed.

- 5 Turn the computer upside down, and remove the bottom plate (A) with the shock absorbers.

Observe the four holes in the shock absorbers and the bottom plate (B).

- 6 Using the bottom plate as a template, mark the position of the mounting bolts on the foundation.

- 7 Mount the bottom plate back on the computer.

- 8 Disassemble the two base rails from the computer by removing the two front Allen bolts (C).

- 9 Remove the bolts, lift the computer up and forward.

- 10 Mount the base rails on the foundation.

- 11 Mount the computer back onto the base rails.

a Hook the unit onto the rails at the rear end.

b Press it down.

c Secure the computer with the two front Allen bolts (C).

- 12 Connect the cables.

Note _____

When you connect the cables, make sure that they are all properly secured, and able to withstand the vibration and movements of the vessel.

Related topics

[Processor Unit outline dimensions, page 175](#)

Installing the transducer(s)

The installation of the transducer (or transducers) is a key task for successful installation of the EK60 system. Not only will you need to penetrate the vessel's hull, you must also to select a physical location for maximum performance and minimum acoustic and electric noise.

Prerequisites

To get a full overview of the installation, you will need all the relevant vessel drawings, as well as the drawings provided for each relevant transducer.

Context

Necessary information for the installation of each transducer can be found in the end user documentation provided with the transducer. The source drawings (in AutoCad format) can be downloaded from our website.

- <http://www.simrad.com>

Procedure

- 1 Based on the shape and properties of the hull, determine the physical location of the transducer.
Make sure that all possible considerations are made to reduce the noise.
- 2 Based on the shape of the transducer housing, and the mounting devices available, determine the installation method.
- 3 Design, manufacture and mount the necessary fairing, installation blister, keel box and/or tank that is required to mount the transducer.
- 4 Design, manufacture and mount the steel conduit for the transducer cable.
- 5 Unpack the transducer from its transport crate.
- 6 Position the transducer under the mounting location.
- 7 Pull the transducer cable up through the steel conduit.
- 8 Tighten the packing nut on the cable gland properly to avoid leaks.
- 9 Mount the transducer.
- 10 Seal the top of the steel conduit to prevent water leaks.
- 11 Connect the transducer cable to the transceiver.

Cable layout and interconnections

Topics

[Read this first, page 60](#)

[Cable plans, page 61](#)

[List of EK60 cables, page 67](#)

[Transceiver interfaces, page 70](#)

[Graphic adapter, page 76](#)

[Moxa CP114EL-I serial port adapter, page 78](#)

[Using a steel conduit to protect the transducer cable, page 79](#)

[Cable drawings and specifications, page 81](#)

[Basic cable requirements, page 120](#)

Read this first

Detailed information about cable specifications, termination and connectors is provided. Unless otherwise specified, all cables are supplied by Kongsberg Maritime as a part of the EK60 delivery.

Note

All electronic installations and corresponding wiring must be in accordance with the vessel's national registry and corresponding maritime authority and/or classification society. If no such guidelines exist, we recommend that Det Norske Veritas (DNV GL) Report No. 80-P008 "Guidelines for Installation and Proposal for Test of Equipment" is used as a guide.

Only trained and authorized personnel can install the EK60 cables.

Kongsberg Maritime will not accept any responsibility for errors, malfunctions or damage to system or personnel caused by improper wiring.

A detailed drawing for each specific cable is provided. Each drawing provides additional information, and may, when applicable, include minimum specifications, connector terminations and the required number of cores.

Drawings are generally not provided for standard commercial cables.

Cables fall into two categories.

- 1 **System cables:** These cables are provided by Kongsberg Maritime as a part of the EK60 delivery.
- 2 **Shipyard cables:** These cables must be provided by the shipyard performing the installation, or the shipowner. It is very important that the cables used meet the minimum specifications provided in this manual.

Kongsberg Maritime accepts no responsibility for damage to the system or reduced operational performance caused by improper wiring.

Note

It is very important that all cables are properly installed and correctly terminated. Observe the relevant regulations and work standards. Always leave enough cable slack close to system units and cabinets to allow for maintenance.

Cable plans

Topics

[About the cable plans, page 61](#)

[Topside computer cable plan, page 62](#)

[Single General Purpose Transceiver \(GPT\) cable plan, page 64](#)

[Dual General Purpose Transceiver \(GPT\) cable plan, page 66](#)

About the cable plans

Due to its modular design, the EK60 system can be set up in a variety of configurations to suit individual needs for operational frequencies, transducers and functionality.

It is not practical to define specific cable plans for all these configurations. To illustrate the variety of configurations, the following basic cable plans are provided:

- Standard topside setup with a computer
- Standard transceiver setup with one General Purpose Transceiver (GPT) unit.
- Standard transceiver setup with two General Purpose Transceiver (GPT) units.

The General Purpose Transceiver used by the Simrad EK60 can be set up to work with maximum four -4- operational frequencies. This means that you can use four single frequency/single beam transducers, two dual frequency transducers, or one split beam transducer.

For scientific work, the EK60 is normally set up with split beam transducers. This means that one General Purpose Transceiver is required for each operational frequency.

Topside computer cable plan

The topside cables include those used to connect the EK60 Processor Unit (computer) and the display to each other, to AC mains power, and to external devices. One Ethernet cable is used to connect the computer to the transceiver.

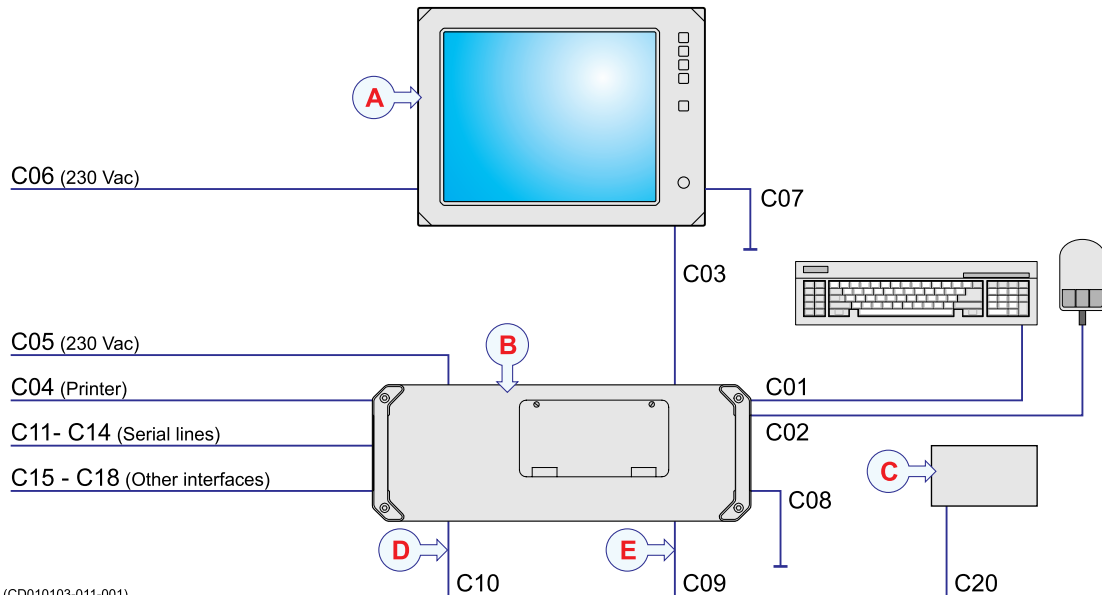

- A Display
- B Processor Unit (computer)
- C Transceiver remote control (Optional)
- D Ethernet cable to the transceiver(s)

Note

It is very important that high quality Ethernet cables are used. You must use CAT-5E STP (Shielded Twisted Pair) quality or better. Cables with lower bandwidth capacity will reduce the EK60 performance. Do not connect the Processor Unit to the transceiver(s) using the vessel's existing local area network.

- E Ethernet cable to the ship's network

Note

Several types of computers have been provided with the Simrad EK60. This drawing shows an APC12 computer. The cabling is however identical for all computer types.

Even though only one Ethernet cable is used, you should install two cables between the Processor Unit and the transceiver(s). This is recommended for redundancy purposes.

Related topics

[List of EK60 cables, page 67](#)

[Cable drawings and specifications, page 81](#)

[Basic cable requirements, page 120](#)

[Graphic adapter, page 76](#)

[Moxa CP114EL-I serial port adapter, page 78](#)

[Moxa CP114EL-I overview, page 78](#)

[Moxa CP114EL-I connectors, page 79](#)

Single General Purpose Transceiver (GPT) cable plan

The transceiver cables include those used to connect the EK60 transceiver(s) to AC mains power, and to the transducer(s). One Ethernet cable is used to connect the transceiver(s) to the topside units.

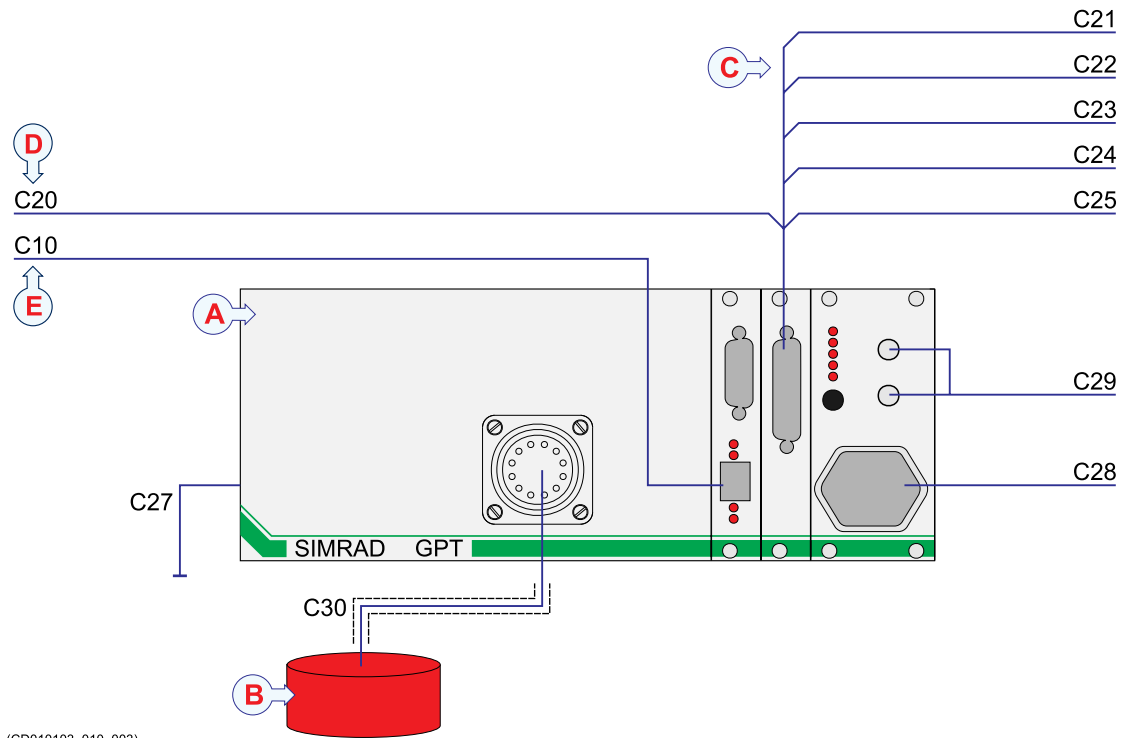

(CD010103_010_003)

- A *Transceiver Unit (General Purpose Transceiver (GPT))*
- B *Transducer*
- C *Interfaces to/from external devices*
- D *Remote on/off to optional control unit on the bridge*
- E *Ethernet cable to the Processor Unit*

Note

It is very important that high quality Ethernet cables are used. You must use CAT-5E STP (Shielded Twisted Pair) quality or better. Cables with lower bandwidth capacity will reduce the EK60 performance.

If more than one General Purpose Transceiver (GPT) is used, a commercial Ethernet switch is inserted on the C10 Ethernet cable between the Processor Unit and the transceivers.

Interface limitations

The following interfaces are not supported by the EK60 software:

- Analogue motion sensor
- Analogue temperature sensor (thermistor)
- Event and New line triggers

Related topics

[List of EK60 cables, page 67](#)

[Cable drawings and specifications, page 81](#)

[Basic cable requirements, page 120](#)

Dual General Purpose Transceiver (GPT) cable plan

The transceiver cables include those used to connect the EK60 transceiver(s) to AC mains power, and to the transducer(s). One Ethernet cable is used to connect the transceiver(s) to the topside units.

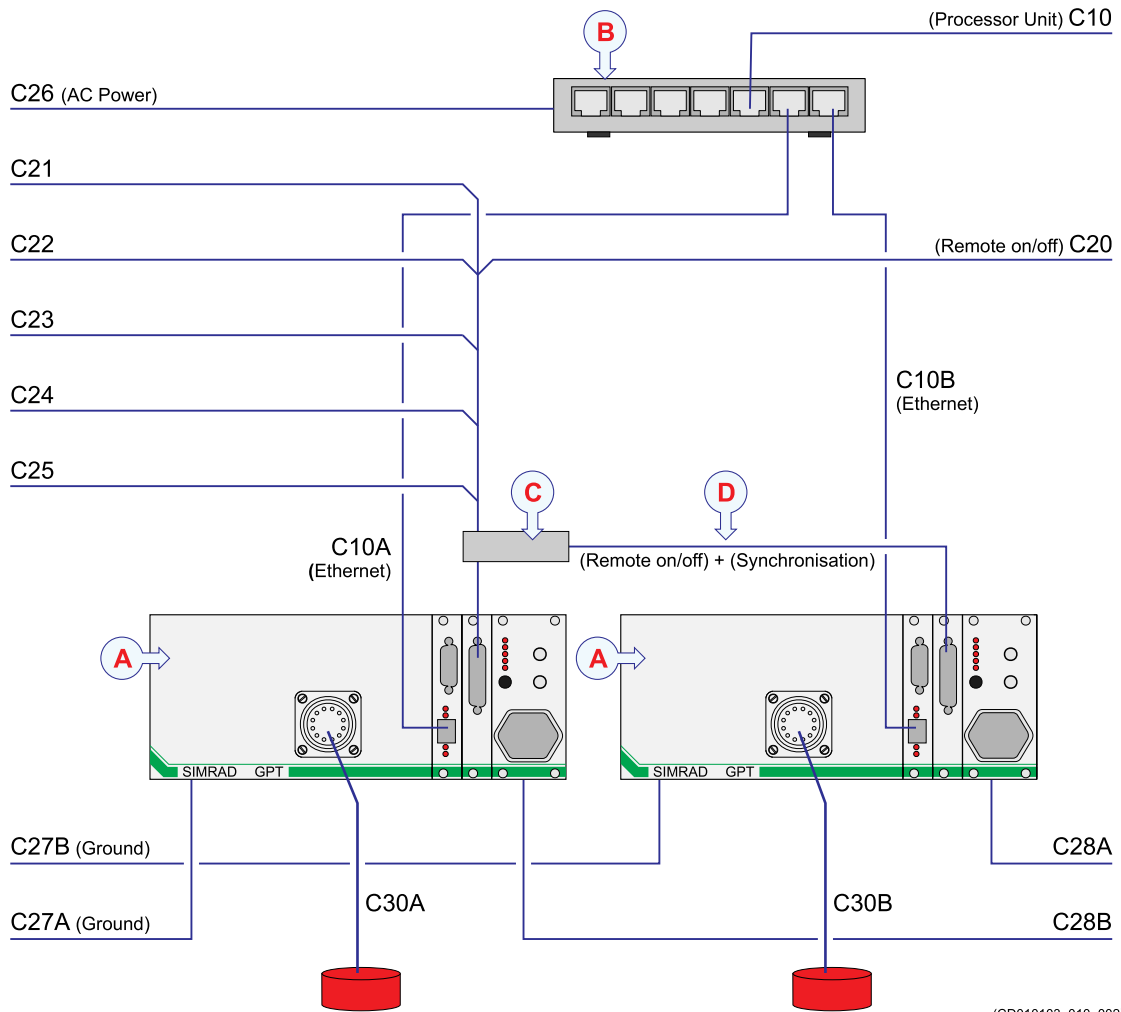

- A *Transceiver Unit (General Purpose Transceiver (GPT))*
- B *Ethernet switch*
- C *Terminal block for wiring*
- D *Only the remote on/off and synchronisation signals must be connected to each transceiver*

Depending on the operational requirements, one or more General Purpose Transceiver (GPT) units may be used in the complete EK60 system. If only one transceiver is used, the Ethernet switch is not required.

Interface limitations

The following interfaces are not supported by the EK60 software:

- Analogue motion sensor
- Analogue temperature sensor (thermistor)
- Event and New line triggers

Related topics

[List of EK60 cables, page 67](#)

[Cable drawings and specifications, page 81](#)

[Basic cable requirements, page 120](#)

List of EK60 cables

A set of cables is required to connect the EK60 system units to each other, to the relevant power source(s), and to peripheral devices.

The following cables are used.

Cable	Signal	From / To	Min. requirements
C1	Keyboard	Processor Unit / Keyboard	See comment 1
C2	Mouse	Processor Unit / Mouse	See comment 1
C3	Video	Processor Unit / Display	See comment 1
C4	Printer	Processor Unit / Printer	See comment 1
C5	AC power	Processor Unit / AC mains	2 x 1.5 mm ² + Ground
C6	AC power	Display / AC mains	2 x 1.5 mm ² + Ground
C7	Ground	Display / Ground	1 x 6 mm ²
C8	Ground	Processor Unit / Ground	1 x 6 mm ²
C9	Ethernet	Processor Unit / Ship's local area network	See comment 2
C10	Ethernet	Processor Unit / Ethernet switch or transceiver	See comment 2
C11–C14	Serial	Processor Unit / Peripheral devices	2 x 4 x 0.5 mm ²
C15–C18	Serial/USB	Processor Unit / Peripheral devices	2 x 4 x 0.5 mm ²
C19	Not used		
C20	Remote	General Purpose Transceiver (GPT) / Remote control box (optional)	2 x 0.22 mm ²
C21	New line	Not implemented in EK60 software	

Cable	Signal	From / To	Min. requirements
C22	Event	Not implemented in EK60 software	
C23	Sync	General Purpose Transceiver (GPT) / External synchronization devices or systems	2 x 2 x 0.22 mm ²
C24	Motion	Not implemented in EK60 software	
C25	Temperature	Not implemented in EK60 software	
C26	Not used		
C27	DC power	General Purpose Transceiver (GPT) / Ground	1 x 6 mm ²
C28	AC Power	General Purpose Transceiver (GPT) / AC mains	2 x 1.5 mm ² + Ground
C29	DC Power	General Purpose Transceiver (GPT) / DC power (battery or external power supply)	See comment 3
C30	Transducer	General Purpose Transceiver (GPT) / Transducer(s)	See comment 4

Comments

- 1 Cables for keyboard, video, printer and display are all commercial cables. They are normally provided with the relevant devices.
- 2 Ethernet cables are commercial.

Note

It is very important that high quality Ethernet cables are used. You must use CAT-5E STP (Shielded Twisted Pair) quality or better. Cables with lower bandwidth capacity will reduce the EK60 performance.

- 3 The DC power cable from the external power supply is provided with the supply. If you wish to power the transceiver from a battery, use any adequate cable, but make sure that the cross section is sufficient.
- 4 The transducer cable is provided with the transducer. If you need to splice the transducer cable to make it longer, observe the information in the end user documentation for the relevant transducer.

Identifying EK60 cables on a project cable drawing

The EK60 is often a part of a project delivery. For such deliveries, project cable drawings are established to show all main cables, and how the various products interconnect. In such project cable drawings, the EK60 cables are identified as **EK60/Cx**.

Related topics

[Topside computer cable plan, page 62](#)

[Single General Purpose Transceiver \(GPT\) cable plan, page 64](#)

[Dual General Purpose Transceiver \(GPT\) cable plan, page 66](#)

[Cable drawings and specifications, page 81](#)

[Basic cable requirements, page 120](#)

Transceiver interfaces

A number of interfaces have been provided to allow the General Purpose Transceiver (GPT) to communicate with the EK60 Processor Unit and peripheral devices.

- A *DC voltage input/output sockets*
- B *Auxiliary connector*
- C *Ethernet connector (not used)*
- D *Ethernet connector (RJ45)*
- E *Transducer connector*
- F *AC mains input connector (with fuse)*

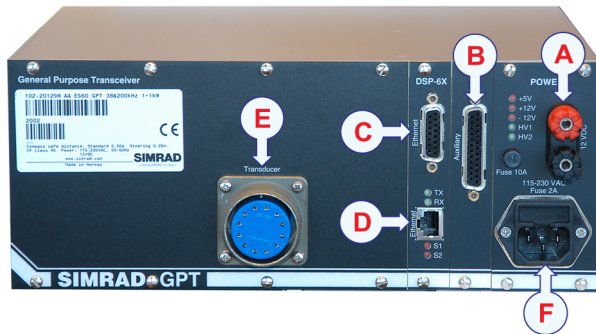

Topics

- [AC mains input, page 70](#)
- [DC input, page 71](#)
- [Auxiliary interface socket, page 71](#)
- [Ethernet AUI connector, page 74](#)
- [Ethernet RJ45 connector, page 74](#)
- [Transducer connector, page 75](#)

AC mains input

The Power Supply board on the General Purpose Transceiver (GPT) offers a standard commercial socket for 115/230 Vac input. The socket holds a fuse.

Note _____

In order to avoid electrical noise, certain transceiver configurations are supplied with an external power supply.

The AC mains input on the General Purpose Transceiver (GPT) is then not used. The DC voltage from the external power supply is connected the DC inputs.



DC input

The two "banana" connectors on the Power Supply board allows you to power the General Purpose Transceiver (GPT) from an external DC power source; for example a car battery, a battery charger or a separate power supply.

Note

In order to avoid electrical noise, certain transceiver configurations are supplied with an external power supply.

These are:

- 18 kHz, 230 Vac
- 38 kHz, 230 Vac



The AC mains input on the General Purpose Transceiver (GPT) is then not used. The DC voltage from the external power supply is connected the DC inputs.

The commercial DC/DC power module used inside other transceiver configurations is not mounted.

Auxiliary interface socket

The Input/Output circuit board on the General Purpose Transceiver (GPT) contains a 25-pin female Delta connector handling various interfaces.

The General Purpose Transceiver (GPT) offers the following interfaces on the large D-connector.

- 1 Analogue motion sensor
- 2 Temperature sensor
- 3 +5 Vdc and ± 12 Vdc outputs
- 4 Transmit synchronisation
- 5 Remote on/off
- 6 Event trigger input
- 7 New line trigger input
- 8 Alarm out



Analogue motion sensor

An analogue heave sensor can be connected to pins 3 and 16 (heave). Roll information can be connected to pins 2 and 15, while a pitch input is connected to pins 1 and 14.

One differential input is connected to the sensor output terminal, the other input is grounded at the sensor. This is done in order to prevent the ground potential offsets between the sensor and the transceiver from being adding to the sensed signal. The differential input range is ± 10 V.

Note

These inputs are not supported by the EK60 Scientific Echo Sounder.

Temperature sensor

A temperature sensor can be connected to pins 4 and 17.

Some transducers contain a built-in temperature sensitive resistor, normally 10 kohm at 25°C. This resistor is used to measure the water temperature.

Note

This input is not supported by the EK60 Scientific Echo Sounder.

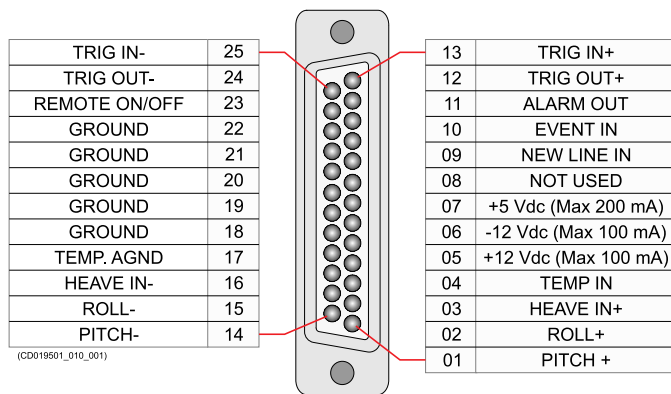

DC outputs

The following DC voltages are provided on the connector to power external instruments. Observe the maximum load!

- **Pin 5:** +12 Vdc, max 100 mA (Ground on pin 18)
- **Pin 6:** -12 Vdc, max 100 mA (Ground on pin 19)
- **Pin 7:** +5 Vdc, max 200 mA (Ground on pin 20)

Transmit synchronisation

Pins 12, 13, 23, 24 and 25 can be used to synchronize the General Purpose Transceiver (GPT) with other hydroacoustic systems.

TrigIn (25/13) and **TrigOut** (24/12) are digital signals provided for transmit synchronisation with external equipment of various types.

TrigOut+ (12) is normally low, and **TrigOut-** is the logical inverse of **TrigOut+**.

- In internal trigger mode, **TrigOut+** goes high (output transistor is not conducting) when the transmit pulse starts, and it goes low again when all frequency channels within the transceiver have finished transmitting. The **TrigIn** signals are totally disregarded.
- In external trigger mode, transmission is delayed until a pulse is detected at one of the **TrigIn** inputs; a low-to-high transition at the **TrigIn+** input or a high-to-low transition at the **TrigIn-** input. **TrigOut+** goes high when the transceiver is ready to

transmit, and it goes low again when all frequency channels within the transceiver have finished transmitting.

Remote on/off

The **RemoteIn** signal at pin 23 switches the transceiver on/off. Left open the transceiver is on. If grounded (less than +2.5 Vdc) the transceiver is off.

If you wish to take advantage of this functionality, you can build a small box with a simple on/off switch, and place it close to the computer.

Event trigger input

Use a simple non-locking push-to-make switch to trigger an event. A vertical line is drawn on the echogram

Note _____

This input is not supported by the EK60 Scientific Echo Sounder.

New line trigger input

Use a simple non-locking push-to-make switch to trigger a new survey line. A vertical line is drawn on the echogram

Note _____

This input is not supported by the EK60 Scientific Echo Sounder.

Alarm out

A positive (+ 5 Vdc) level is provided when the alarm is enabled.

On the EK60, this output is used to control the optional multiplexer.

Important _____

Note that this output must not be used to power lamps, speakers or sounder directly. The alarm signal must be connected to an optocoupler, a relay or a similar device to power peripheral alarm units.

Ethernet AUI connector

The Ethernet AUI connector on the General Purpose Transceiver (GPT) provides a standard Attachment Unit Interface (AUI) interface.

An Attachment Unit Interface (AUI) is a 15 pin connection that provides a path between a node's Ethernet interface and the Medium Attachment Unit (MAU), sometimes known as a transceiver. It is the part of the IEEE Ethernet standard located between the Media Access Control (MAC), and the MAU.



An AUI cable may be up to 50 meters long, although frequently the cable is omitted altogether and the MAU and MAC are directly attached to one another.

AUI connectors became rare beginning in the early 1990s when computers and hubs began to incorporate the MAU, particularly as the 10BASE-T standard became more common and use of 10BASE-5 (thicknet) and 10BASE-2 (thinnet) declined. The electrical AUI connection was still present inside the equipment. By the mid-1990s AUI had all but disappeared as fast Ethernet became more common.

https://en.wikipedia.org/wiki/Attachment_Unit_Interface, June 2012

This connector is no longer in use.

Ethernet RJ45 connector

The Ethernet RJ45 connector on the General Purpose Transceiver (GPT) is used to connect the cable from the transceiver and up to the Processor Unit.

If your EK60 system is setup using only one General Purpose Transceiver (GPT), the Ethernet cable is connected from the Input/Output board and directly to the Processor Unit's Ethernet adapter. If more than one transceiver is used, you must provide a high speed Ethernet switch. Use one Ethernet cable from each transceiver to the switch, and one cable from the switch to the Processor Unit.



Note

It is very important that a high quality Ethernet cable is used. You must use CAT-5E quality or better. Cables with lower bandwidth capacity will reduce the EK60 performance.

Transducer connector

The transducer connector is mounted on the front panel of the General Purpose Transceiver (GPT).

The transducer connector is mounted on the front panel of the General Purpose Transceiver. The transducer connector is a circular socket with 12 pins identified as A through N.

The pin assignment is:

- A Channel 4 +
- B Channel 4 –
- C Channel 3 +
- D Channel 3 –
- E Channel 2 +
- F Channel 2 –
- G (Not designated on socket)
- H Channel 1 +
- I (Not designated on socket)
- J Channel 1 –
- K Ground
- L Not used
- M Not used
- N Chassis ground



The General Purpose Transceiver used by the Simrad EK60 can be set up to work with maximum four -4- operational frequencies. This means that you can use four single frequency/single beam transducers, two dual frequency transducers, or one split beam transducer.

For scientific work, the EK60 is normally set up with split beam transducers. This means that one General Purpose Transceiver is required for each operational frequency.

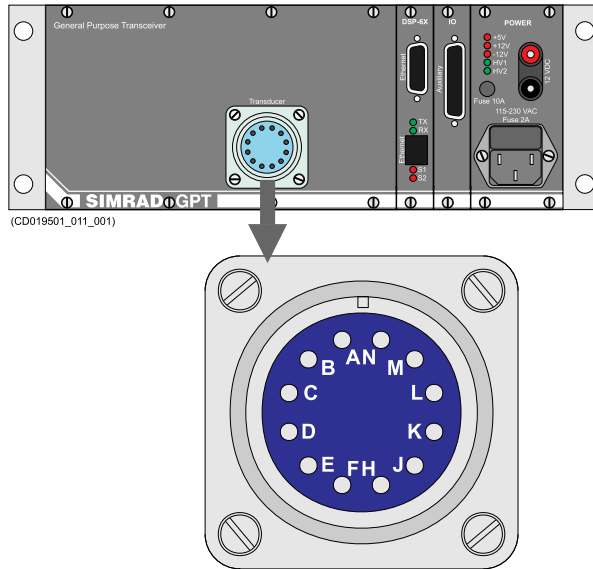

Graphic adapter

The graphic adapter used by the Enix Processor Unit is the **ER93F** manufactured by TUL.

(Photo downloaded from www.tulembedded.com, 2015)

Description

The manufacturer's website offers the following description of the ER39F graphic adapter.

The ER93F Graphic Card is provided with two DVI, two Mini DP and one HDMI port, allowing system customers to implement multi-display output without additional video converters or splitters. The graphic card's complete range of output ports is perfect for developing new system products or upgrading an existing product. The ER93F is particularly suitable for upgrading existing digital signage equipment or arcade machine. Apart from the variety of output ports, the two sets of Mini DP and DVI outputs allow old systems to be upgraded directly to multi-display solutions.

The ER93F Graphic Card uses the embedded E6760 graphics chip from AMD and incorporates 128-bit 1GB GDDR5 memory in MCM BGA packaging. Industrial-grade passive electronic components are used throughout the entire card and it has been tested between -20 ~ 55°C to ensure ideal system compatibility and reliability. For industrial and automation industry customers, this resolves any doubt about compatibility and stability on production selection and system configuration.

www.tulembedded.com, March 2015

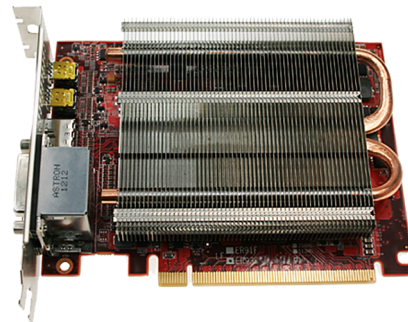

Outputs and resolutions

The following video outputs are provided.

- **Display Port**, maximum resolution 2560 x 1600 px
- **HDMI**, maximum resolution 1920 x 1200 px
- **DVI-I/D**, maximum resolution 2560 x 1600 px
- **VGA** (using adapter), maximum resolution 2048 x 1536 px

The outputs from the graphic adapters are positioned as follows:

- A *DisplayPort output*
- B *DisplayPort output*
- C *HDMI output*
- D *DVI-I output*
- E *DVI-D output*

Note

The two DVI outputs are not identical. If you wish to connect a standard VGA display using a DVI-to-VGA adapter, you must use the left output (D).

(Photo downloaded from www.tuleembedded.com, 2015)

Tip

To learn more about the various video standards, explore these Wikipedia pages.

[SVGA description](#)

[DVI description](#)

[HDMI description](#)

[DisplayPort description](#)

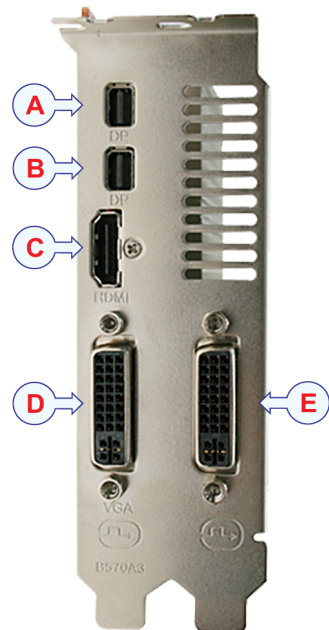

Related topics

[Topside computer cable plan, page 62](#)

Moxa CP114EL-I serial port adapter

The **Moxa CP114EL-I** serial port adapter is used in the EK60 Processor Unit to provide serial communication.

Topics

[Moxa CP114EL-I overview, page 78](#)

[Moxa CP114EL-I connectors, page 79](#)

[Moxa CP114EL-I overview, page 78](#)

[Moxa CP114EL-I connectors, page 79](#)

Moxa CP114EL-I overview

The Processor Unit is equipped with a **Moxa CP114EL-I** serial adapter board. The board provides four serial lines.

The Moxa CP114EL-I serial line adapter board supports RS-232, RS-422 and RS-485 (both 2 and 4-wire).

The connections to the board are made using a converter cable with four 9-pin male D-connectors. The converter cable is supplied with the Processor Unit.

The board is manufactured by Moxa at <http://www.moxa.com/>



Serial line support

The **Moxa CP114EL-I** serial adapter board supports the following interface formats:

- **Port 1:** RS-232 / RS-422 / RS-485
- **Port 2:** RS-232 / RS-422 / RS-485
- **Port 3:** RS-232 / RS-422 / RS-485
- **Port 4:** RS-232 / RS-422 / RS-485

A dedicated software utility in the device driver is used to set up the ports to match your requirements. For this reason, there are neither jumpers nor DIP switches on the circuit board.

Related topics

[Topside computer cable plan, page 62](#)

Moxa CP114EL-I connectors

The Moxa CP114EL-I serial line adapter board provides a front mounted D-connector for its serial lines.

A dedicated adapter cable is provided with the EK60 delivery. It splits the large front mounted connector to four 9-pin D-connectors.

To make the individual connections easier, four 9-pin D-sub connectors with screw terminals, and a number of adapter nuts for connection to the adapter cable, are also included in the delivery.

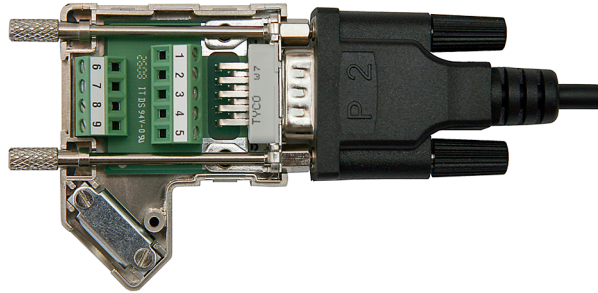

Pin assignments

Moxa CP114EL-I 9-pin D-connector converter				
Pin	RS-232	RS-422	RS485 (4-wire)	RS485 (2-wire)
1	DCD	TXD-(A)	TXD-(A)	
2	RxD	TXD+(B)	TXD+(B)	
3	TxD	RXD+(B)	RXD+(B)	Data-(B)
4	DTR	RXD-(A)	RXD-(A)	Data-(A)
5	GND	GND	GND	GND
6	DSR			
7	RTS			
8	CTS			
9				

Related topics

[Topside computer cable plan, page 62](#)

Using a steel conduit to protect the transducer cable

A steel conduit is used to protect the transducer cable.

Why use steel conduits?

It is strongly recommended to lay a steel conduit from the transducer's cable gland to the EK60 transceiver, and to pull the transducer cable through this conduit.

There are several reasons for this.

- It will make it easier at a later stage to replace the transducer.
- Noise and interference from other electrical equipment is greatly reduced.
- The risk of flooding is greatly reduced if the steel conduit is terminated above the water line.

With a steel conduit the installation will satisfy the European Union regulations for electromagnetic compatibility (EMC) interference. Without a steel conduit, there is a risk of reduced EK60 performance.

Steel conduits qualities and shielding

The steel conduit must be unbroken and watertight from the transducer to above the water line. From there, the cable can be pulled further, or a junction box can be installed to facilitate further connections.

Note

The steel conduit must act as a continuous electrical screen all the way.

The minimum dimensions of the steel conduit must be specified by the relevant maritime authority and/or classification society.

More than one transducer cable?

If two or more transducers are installed close to each other it is possible to pull their cables in the same steel conduit, provided the conduit diameter is increased accordingly. However, for easy replacement it is recommended that each transducer has its own steel conduit.

Cable drawings and specifications

Relevant cables and connections required for the EK60 are described in detail.

Topics

- [AC mains power cable using IEC C13 inline socket, page 82](#)
- [Generic RS-232 connection using three wires, page 84](#)
- [Generic RS-232 connection using five wires, page 85](#)
- [RS-232 used as synchronization trigger \(input or output\), page 86](#)
- [Generic RS-422 serial line using five wires, page 87](#)
- [Generic RS-485 connection using two or four wires, page 88](#)
- [Moxa CP114EL-I Serial line adapter, page 89](#)
- [RJ45 High speed Ethernet cable \(1000Base-t\), page 91](#)
- [General Purpose Transceiver \(GPT\) external power supply, page 92](#)
- [General Purpose Transceiver \(GPT\) remote on/off, page 93](#)
- [General Purpose Transceiver \(GPT\) transmit synchronization, page 95](#)
- [Single beam low power transducer connection to a GPT Transducer socket, page 96](#)
- [Single beam high power transducer connection to a GPT Transducer socket, page 97](#)
- [Dual single beam transducer connection to a GPT Transducer socket, page 98](#)
- [Split beam transducer; connections and specifications, page 100](#)
- [Split beam transducer to single beam output on GPT Transducer socket, page 102](#)
- [Split beam transducer connection to a GPT Transducer socket wired for single beam high output, page 103](#)
- [Transducer 12-16/60 connection to a GPT Transducer socket, page 105](#)
- [Transducer ES18 connection to a GPT transducer socket, page 106](#)
- [Transducer ES38-7 connection to a GPT transducer socket, page 107](#)
- [Transducer ES38-10 connection to a GPT Transducer socket, page 108](#)
- [Transducer 38/200 Combi C connection to a GPT Transducer socket, page 109](#)
- [Transducer ES38-18/200-18C connection to a GPT transducer socket, page 111](#)
- [Transducer 50/200 Combi C connection to a GPT Transducer socket, page 112](#)
- [Transducer ES70-18CD connection to a GPT Transducer socket, page 114](#)
- [Burton underwater connectors on split beam transducers for deep water, page 115](#)
- [About serial lines, page 117](#)

AC mains power cable using IEC C13 inline socket

This is a commercial power cable normally used for 230 Vac mains power. The inline socket and plug comply to the IEC60320 standard.

A standard commercial AC mains cable is used.

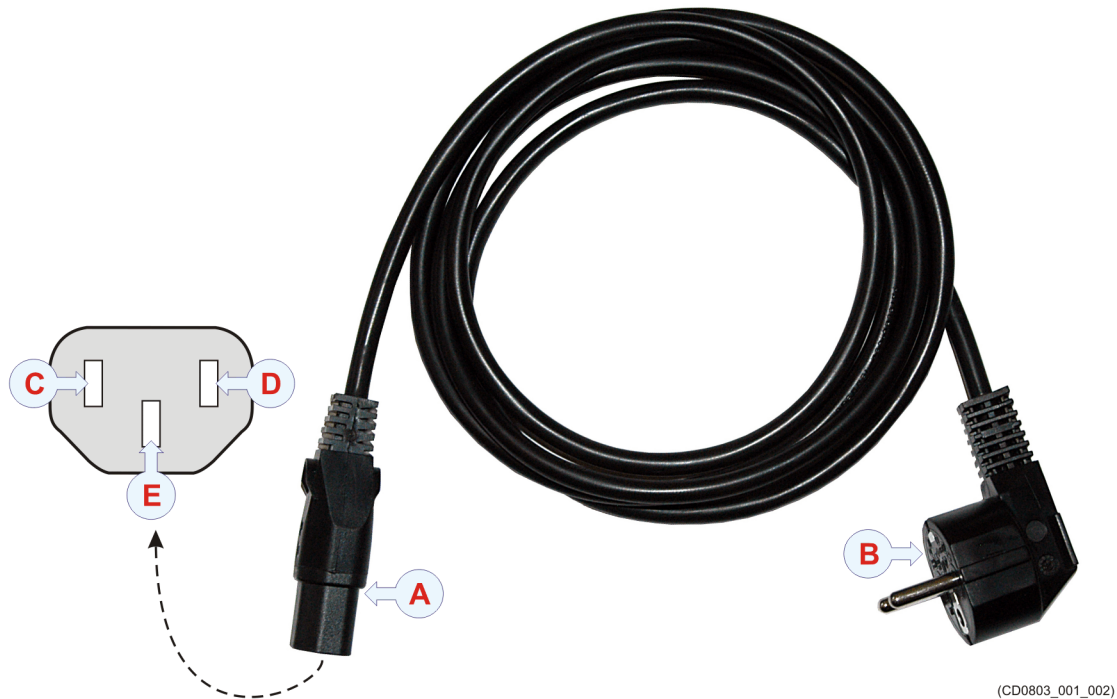

- A IEC13 line socket – may be fitted with a locking device
- B CEE 7/7 male power plug
- C Live (normally identified with Blue insulation)
- D Neutral (normally identified with Brown insulation)
- E Ground (normally identified with Yellow or Yellow/Green insulation)

The power cable is normally terminated with an female IEC C13 inline socket. The AC mains end is terminated in an AC connector suitable for the local standard and/or the output sockets on a Uninterruptible Power Supply (UPS) unit. If this is not the case, you must replace the AC connector.

The typical cable length is between 1,5 and 2 meters. If this is too short you must use an extension cable (not recommended), mount a new power outlet within range, or make your own power cable with sufficient length. If you use an Uninterruptible Power Supply (UPS), you can also move the UPS unit to a different location within range.

Note

There are substantial differences between American and British nomenclature related to power plugs and sockets. Observe local standards and regulations.

Minimum cable requirements

- **Conductors:** 2 x 1.5 mm² + GND
- **Screen:** None
- **Voltage:** 750 V
- **Maximum outer diameter:** Defined by the plugs

Generic RS-232 connection using three wires

An RS-232 serial line connection using three (3) wires and NMEA telegrams is a common way to connect the EK60 to external devices.

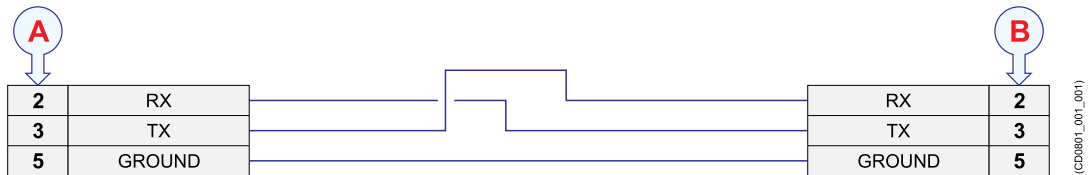

- A *Local connection*
- B *Connection on peripheral device*
- C *Female 9-pin D-connector*
- D *Male 9-pin D-connector*

Unless otherwise specified, the serial line cable must be provided by the installation shipyard.

Note that this cable does not support all the signals in the standard RS-232 specification.

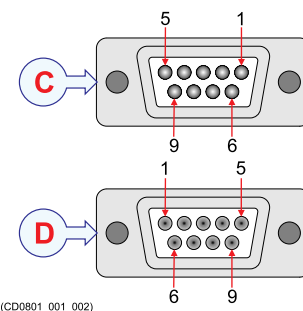

Minimum cable requirements

- **Conductors:** 2 x 4 x 0.5 mm²
- **Screen:** Overall braided
- **Voltage:** 60 V
- **Maximum outer diameter:** Defined by the plugs

If you need to install a very long serial line cable, increase the cross section.

Related topics

[About serial lines, page 117](#)

Generic RS-232 connection using five wires

An RS-232 serial line connection using five (5) wires and NMEA telegrams is a common way to connect the EK60 to external devices.

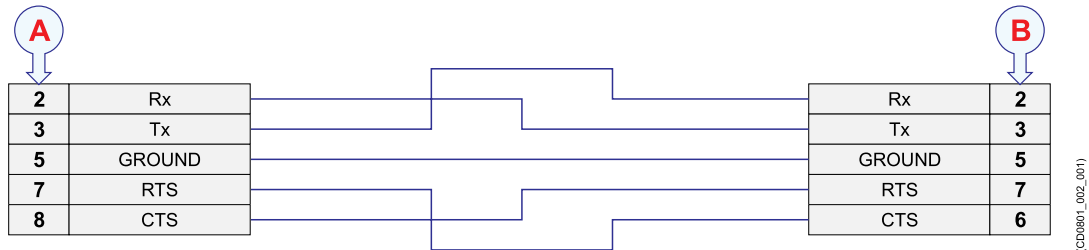

- A *Local connection*
- B *Connection on peripheral device*
- C *Female 9-pin D-connector*
- D *Male 9-pin D-connector*

Unless otherwise specified, the serial line cable must be provided by the installation shipyard.

Note that this cable does not support all the signals in the standard RS-232 specification.

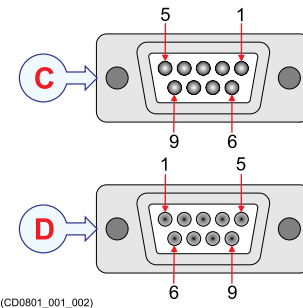

Minimum cable requirements

- **Conductors:** 2 x 4 x 0.5 mm²
- **Screen:** Overall braided
- **Voltage:** 60 V
- **Maximum outer diameter:** Defined by the plugs

If you need to install a very long serial line cable, increase the cross section.

Related topics

[About serial lines, page 117](#)

RS-232 used as synchronization trigger (input or output)

An RS-232 serial line connection using the Request To Send (RTS) and Clear To Send (CTS) signals is common way to connect the EK60 to external devices for synchronization purposes.

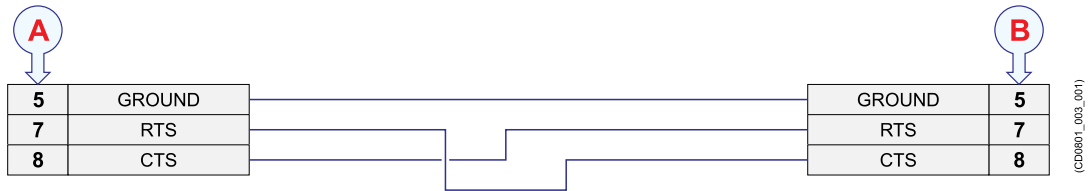

- A *Local connection*
- B *Connection on peripheral device*
- C *Female 9-pin D-connector*
- D *Male 9-pin D-connector*

This cable comprises an RS-232 serial line applied as an external trigger. It provides interface with any peripheral unit that requires or controls transmit/receive synchronization.

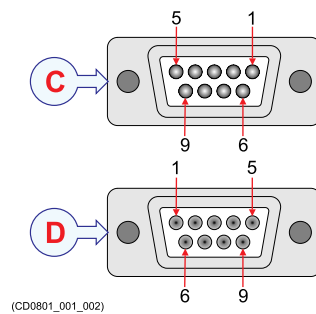

Note that this cable does not support all the signals in the standard RS-232 specification.

Unless otherwise specified, the serial line cable must be provided by the installation shipyard.

Minimum cable requirements

- **Conductors:** 2 x 4 x 0.5 mm²
- **Screen:** Overall braided
- **Voltage:** 60 V
- **Maximum outer diameter:** Defined by the plugs

If you need to install a very long serial line cable, increase the cross section.

Related topics

[About serial lines, page 117](#)

Generic RS-422 serial line using five wires

An RS-422 serial line connection can transmit data at rates as high as 10 million bits per second, and may be sent on cables as long as 1500 meters.

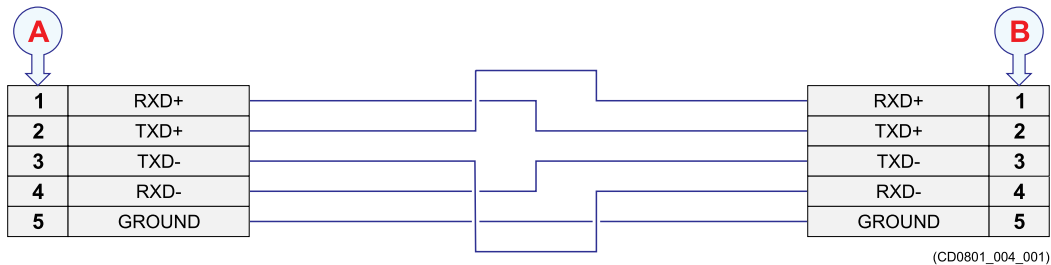

A *Local connection*

B *Connection on peripheral device (typical example)*

Note that the pin numbers on your peripheral device may be different from those shown here!

C *Female 9-pin D-connector*

D *Male 9-pin D-connector*

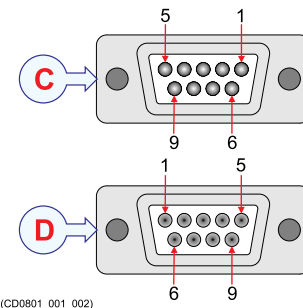

Unless otherwise specified, the serial line cable must be provided by the installation shipyard.

Minimum cable requirements

- **Conductors:** 2 x 4 x 0.5 mm²
- **Screen:** Overall braided
- **Voltage:** 60 V
- **Maximum outer diameter:** Defined by the plugs

If you need to install a very long serial line cable, increase the cross section.

Related topics

[About serial lines, page 117](#)

Generic RS-485 connection using two or four wires

An RS-485 serial line connection using two or four wires is common way to connect the EK60 to external devices. This format is recommended if the serial cable needs to be very long.

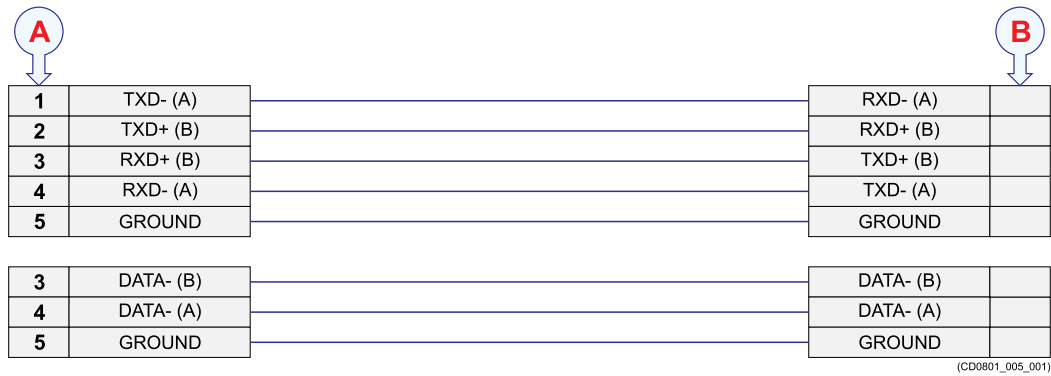

- A *Local connection with pin configuration for Moxa CP114EL-I serial adapter*
- B *Connection on peripheral device – refer to manufacturer’s documentation for pin configuration*
- C *Female 9-pin D-connector*
- D *Male 9-pin D-connector*

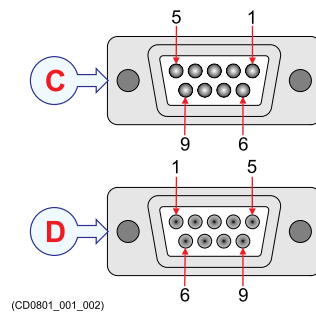

Unless otherwise specified, the serial line cable must be provided by the installation shipyard.

Minimum cable requirements

- **Conductors:** 2 x 5 x 0.5 mm²
- **Screen:** Overall braided
- **Voltage:** 60 V
- **Maximum outer diameter:** Defined by the plugs

If you need to install a very long serial line cable, increase the cross section.

Related topics

[About serial lines, page 117](#)

Moxa CP114EL-I Serial line adapter

The Processor Unit is equipped with a **Moxa CP114EL-I** serial adapter board. The board provides four serial lines.

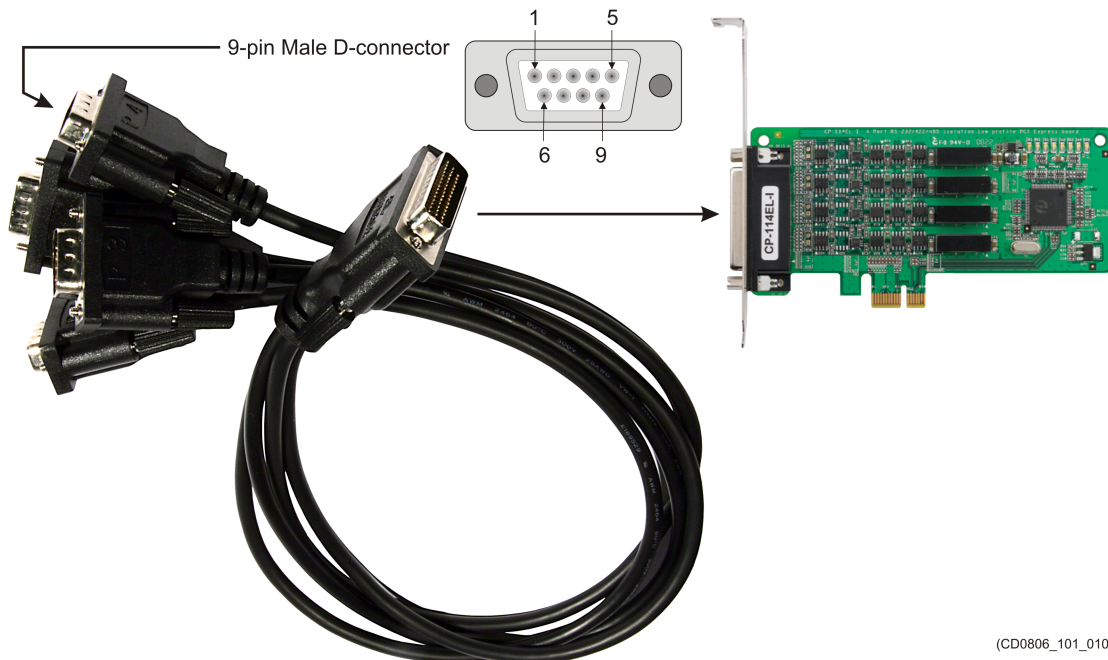

(CD0806_101_010)

The Moxa CP114EL-I serial line adapter board supports RS-232, RS-422 and RS-485 (both 2 and 4-wire).

The connections to the board are made using a converter cable with four 9-pin male D-connectors. The converter cable is supplied with the Processor Unit.

The board is manufactured by Moxa at <http://www.moxa.com/>

Unless otherwise specified, the serial line cable must be provided by the installation shipyard.

Important

When you are using RS-232 serial communication, observe that long runs of unshielded cable will pick up noise easily. This is because the RS-232 signals are not balanced.

Maximum length for an RS-232 serial cable is typically 60 meters with 2400 bps data rate, however this depends on the cable quality. Always check the cable manufacturers specifications for the actual "shunt capacitance". A common figure is 47.5 pF/m, which gives a maximum cable length of about 50 meters.

Note

Even though a standard exist for RS-232 pin configuration, certain manufacturer may still choose their own connector pins for the various signals used. In order to make the RS-232 connection to your peripheral device work properly, you must always consult the relevant instructions provided by the device manufacturer.

Pin assignments

Moxa CP114EL-I 9-pin D-connector converter				
Pin	RS-232	RS-422	RS485 (4-wire)	RS485 (2-wire)
1	DCD	TXD-(A)	TXD-(A)	
2	RxD	TXD+(B)	TXD+(B)	
3	TxD	RXD+(B)	RXD+(B)	Data-(B)
4	DTR	RXD-(A)	RXD-(A)	Data-(A)
5	GND	GND	GND	GND
6	DSR			
7	RTS			
8	CTS			
9				

Minimum cable requirements

- **Conductors:** 2 x 5 x 0.5 mm²
- **Screen:** Overall braided
- **Voltage:** 60 V
- **Maximum outer diameter:** Defined by the plugs

If you need to install a very long serial line cable, increase the cross section.

Related topics

[About serial lines, page 117](#)

RJ45 High speed Ethernet cable (1000Base-t)

Most high speed data connections between the EK60 system units are made using Ethernet cables. These cables may also be used between the EK60 and peripheral equipment.



- A *Local Ethernet connection*
- B *Connection on external network device*

Ethernet cables are available commercially in different lengths, colours and categories. Normally, CAT-5E and CAT-6 cables are used in local area networks with bandwidths exceeding 100 Mbit.

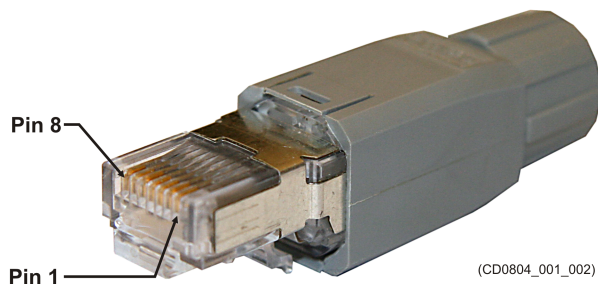

Note

It is very important that high quality Ethernet cables are used. You must use CAT-5E STP (Shielded Twisted Pair) quality or better. Cables with lower bandwidth capacity will reduce the EK60 performance.

Cable specifications

Not applicable. This is a commercial cable.

General Purpose Transceiver (GPT) external power supply

In order to suppress electric noise, certain echo sounder configurations require an external power supply. This power supply is then used instead of the 230 Vac power cable.

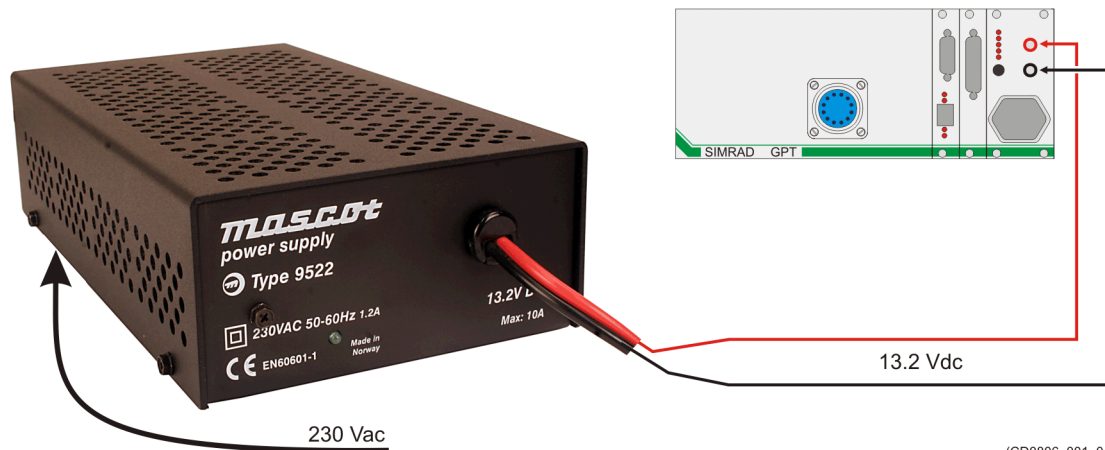

The power cables are connected to the DC input sockets on the General Purpose Transceiver (GPT).

Note

The external power supply is not required for transceivers operating on 115 Vac.

Cable specifications

Not applicable. This cable is provided with the power supply.

General Purpose Transceiver (GPT) remote on/off

An optional cable may be used to connect a remote on/off switch to the General Purpose Transceiver (GPT). The switch can be located in a separate box manufactured by the installation shipyard, or incorporated on a common switch panel.

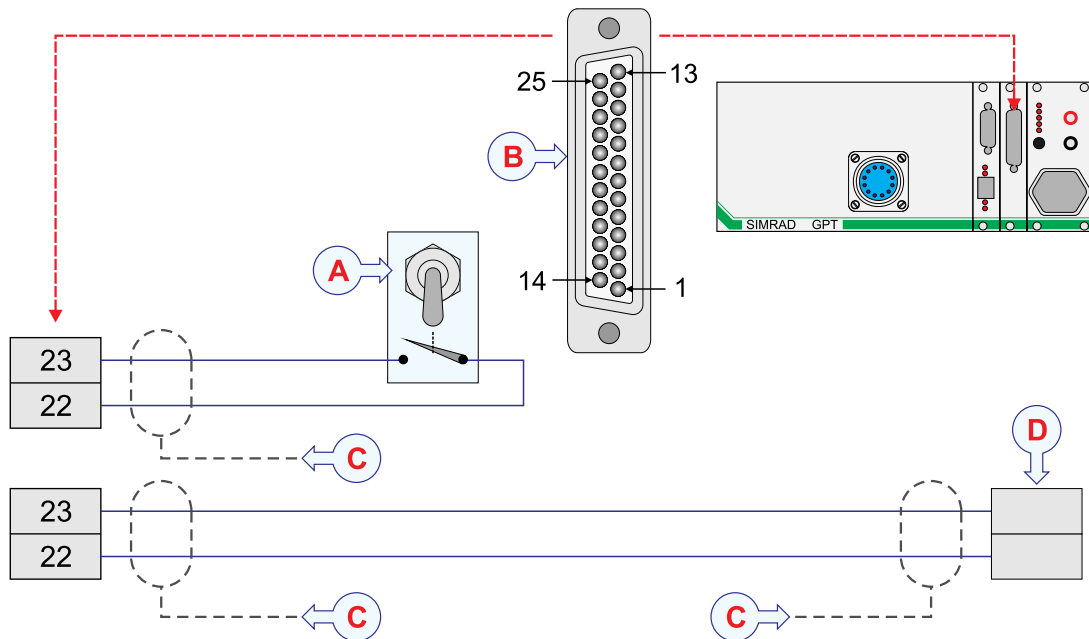

- A On/off switch on locally manufactured junction box
- B Auxiliary connector
- C Cable screen connected to the plug house of the Auxiliary connector
- D Remote control socket on computer or display

Minimum cable requirements

- **Conductors:** 2 x 0.22 mm²
- **Screen:** Overall braided
- **Voltage:** 60 V
- **Maximum outer diameter:** Defined by the plugs

Remote power on/off when multiple transceivers are used

When multiple transceivers are used, two wiring options are available:

- You can switch all transceivers off and on simultaneously using a single switch.
- You can use one switch for each transceiver and switch power on and off individually.

Both options are illustrated below using five transceivers as an example.

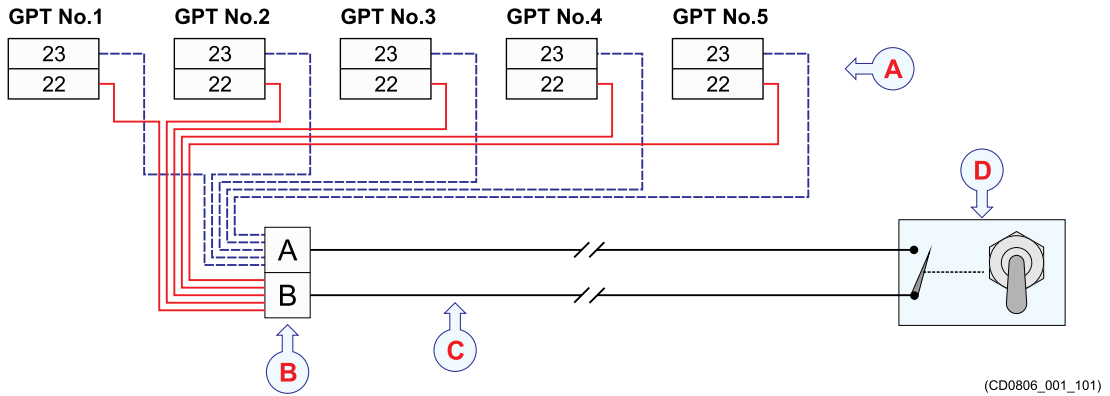

- A Individual transceivers
- B Junction box
- C Cable from sonar room to topside
- D Locally manufactured switch box

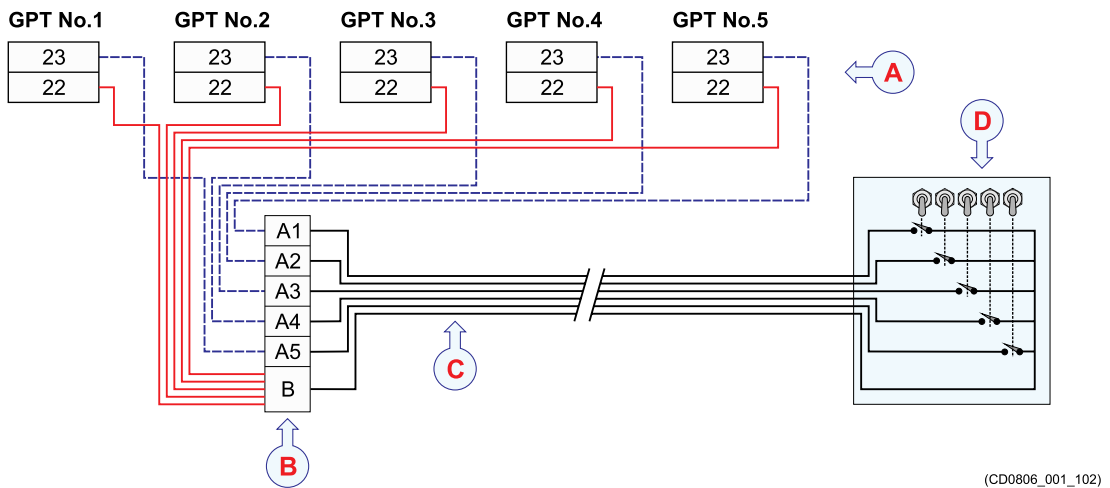

- A Individual transceivers
- B Junction box
- C Cable from sonar room to topside
- D Locally manufactured switch box

General Purpose Transceiver (GPT) transmit synchronization

An optional cable may be used to connect the General Purpose Transceiver (GPT) to an external system for synchronisation purposes.

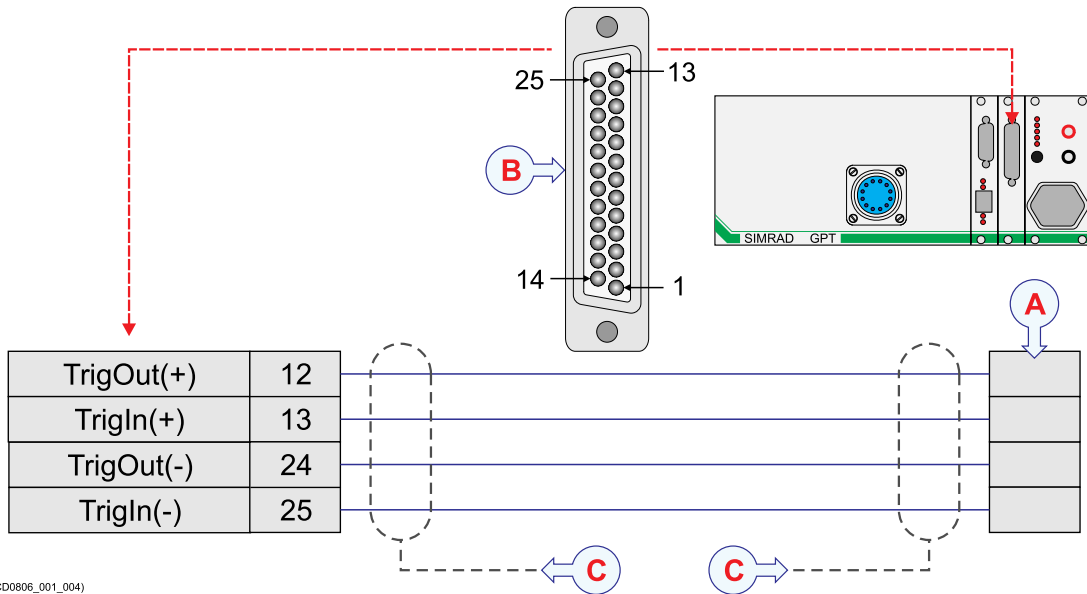

A *Remote system*

B *Auxiliary connector*

C *Cable screen connected to the plug house of the Auxiliary connector*

Minimum cable requirements

- **Conductors:** 2 x 2 x 0.22 mm²
- **Screen:** Braided pairs and overall braided
- **Voltage:** 60 V
- **Maximum outer diameter:** Defined by the plugs

Single beam low power transducer connection to a GPT Transducer socket

A single beam low power transducer can be connected to sockets **D** and **E** on a GPT type transducer socket.

The other end of the cable is permanently fixed to the transducer.

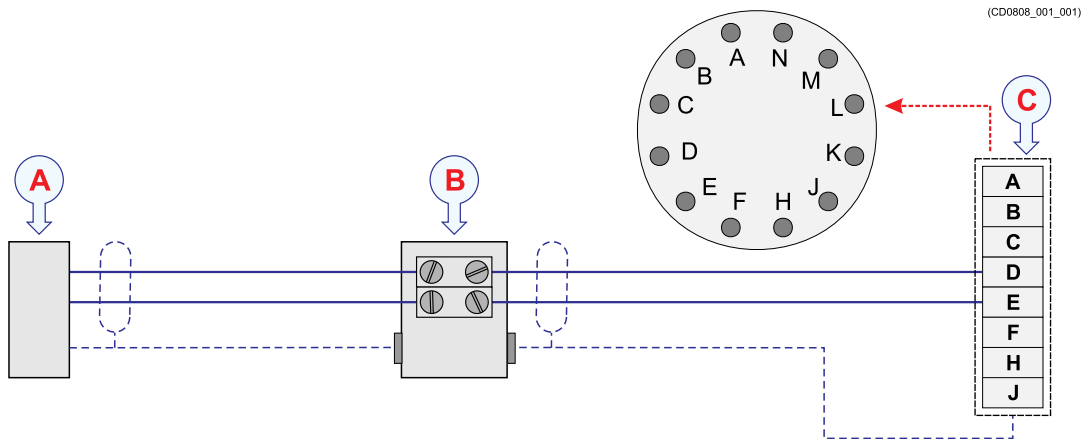

- A *Transducer*
- B *Optional junction box*
- C *GPT transducer connector*

The cable screen must be connected to the housing on the transducer plug. If a junction box is used to extend the cable, the screen must be connected to the cable glands on the box. The screen must not be connected to vessel ground.

If you need to splice the transducer cable, it is very important to use the correct cable. You must also avoid ground loops. We strongly recommend the use of a junction box. The junction box must be made of metal, it must be provided with proper cable glands, and its chassis must not be connected to vessel ground.

We strongly recommend that you install the transducer cable in a steel conduit.

Cable specifications

Not applicable. If you need an extension cable, contact your dealer – or Simrad – for advice.

Single beam high power transducer connection to a GPT Transducer socket

A single beam high power transducer can be connected to sockets **A** through **J** on a GPT type transducer socket.

The other end of the cable is permanently fixed to the transducer.

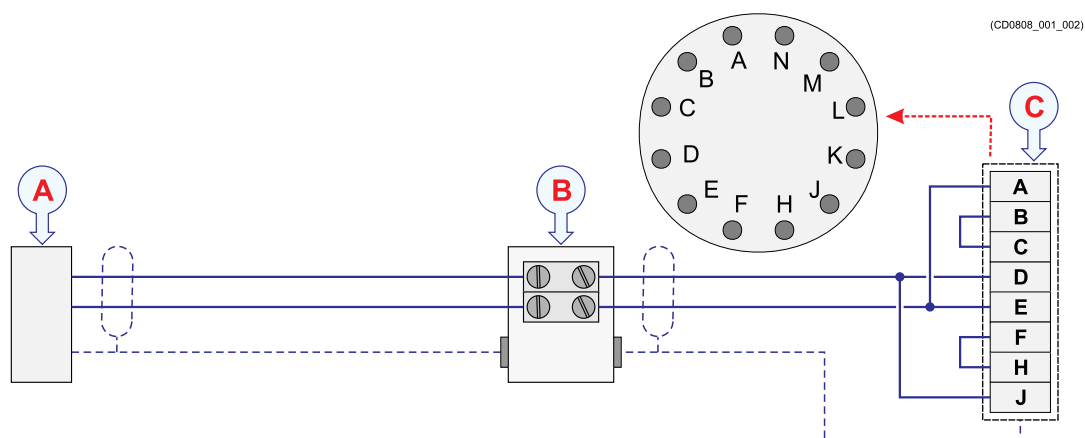

- A *Transducer*
- B *Optional junction box*
- C *GPT transducer connector*

The cable screen must be connected to the housing on the transducer plug. If a junction box is used to extend the cable, the screen must be connected to the cable glands on the box. The screen must not be connected to vessel ground.

If you need to splice the transducer cable, it is very important to use the correct cable. You must also avoid ground loops. We strongly recommend the use of a junction box. The junction box must be made of metal, it must be provided with proper cable glands, and its chassis must not be connected to vessel ground.

We strongly recommend that you install the transducer cable in a steel conduit.

Cable specifications

Not applicable. If you need an extension cable, contact your dealer – or Simrad – for advice.

Dual single beam transducer connection to a GPT Transducer socket

A dual single beam transducer can be connected to sockets **C** and **D** plus **H** and **J** on a GPT type transducer socket.

The other end of the cable is permanently fixed to the transducer.

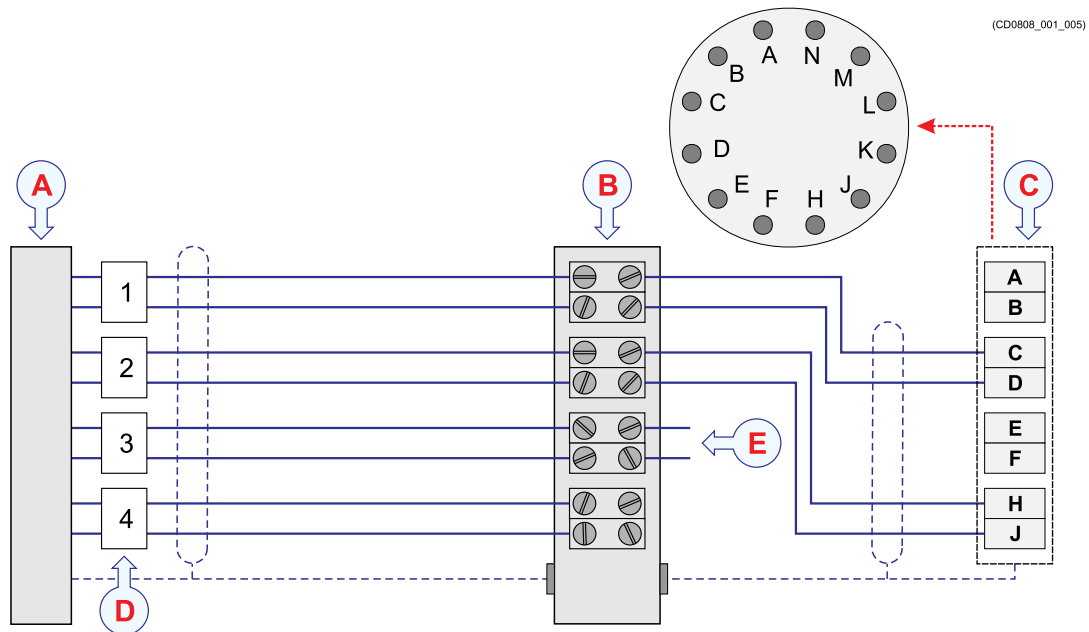

- A *Transducer*
- B *Optional junction box*
- C *GPT transducer connector*
- D *Cable pairs – each pair has a black and a white wire*
- E *Thermistor output*

The cable screen must be connected to the housing on the transducer plug. If a junction box is used to extend the cable, the screen must be connected to the cable glands on the box. The screen must not be connected to vessel ground.

Cable pair 4 is not used. Cable pair 3 is connected to the thermistor that has been built into the transducer body on some transducer types.

The thermistor output wires must be connected to the relevant analogue input on your EK60 system.

The EK60 software does not support input from a temperature sensor.

If you need to splice the transducer cable, it is very important to use the correct cable. You must also avoid ground loops. We strongly recommend the use of a junction box. The junction box must be made of metal, it must be provided with proper cable glands, and its chassis must not be connected to vessel ground.

We strongly recommend that you install the transducer cable in a steel conduit.

Cable specifications

Not applicable. If you need an extension cable, contact your dealer – or Simrad – for advice.

Split beam transducer; connections and specifications

A split beam transducer can be connected to sockets **A** through **J** on a GPT type transducer socket.

This is the termination of the transducer cable from a split beam transducer to a GPT type transducer socket.

The other end of the cable is permanently fixed to the transducer.

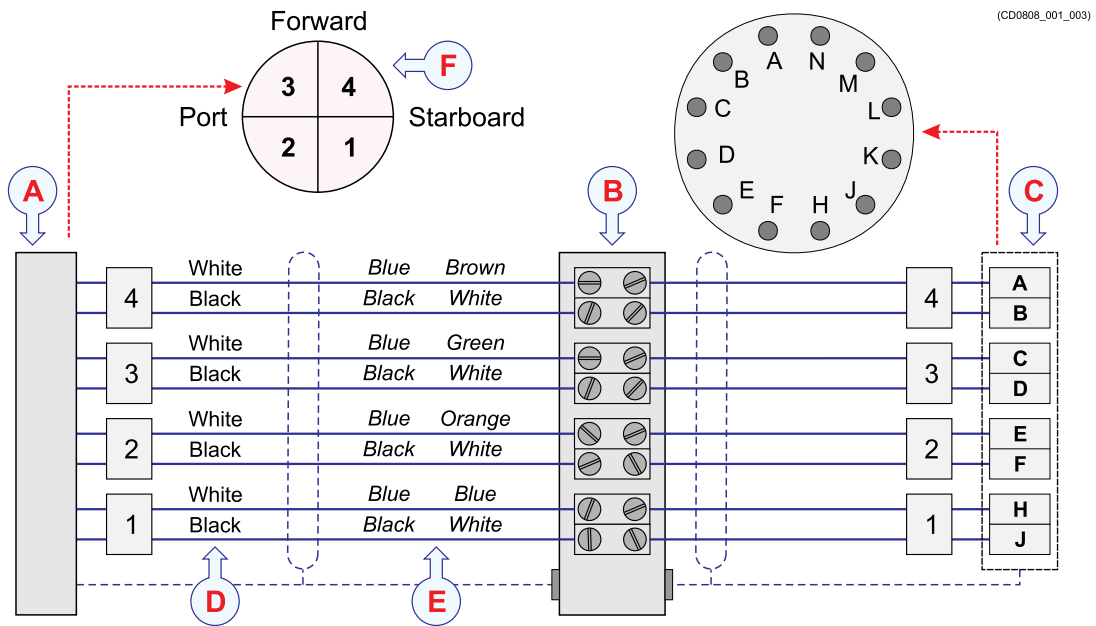

The cable screen must be connected to the housing on the transducer plug. If a junction box is used to extend the cable, the screen must be connected to the cable glands on the box. The screen must not be connected to vessel ground.

If you need to splice the transducer cable, it is very important to use the correct cable. You must also avoid ground loops. We strongly recommend the use of a junction box. The junction box must be made of metal, it must be provided with proper cable glands, and its chassis must not be connected to vessel ground.

We strongly recommend that you install the transducer cable in a steel conduit.

Cable specifications

Not applicable. If you need an extension cable, contact your dealer – or Simrad – for advice.

Split beam transducer to single beam output on GPT Transducer socket

A split beam transducer can be connected to sockets C and D on a GPT type transducer socket. This allows you to use the transducer as a single beam unit.

The other end of the cable is permanently fixed to the transducer.

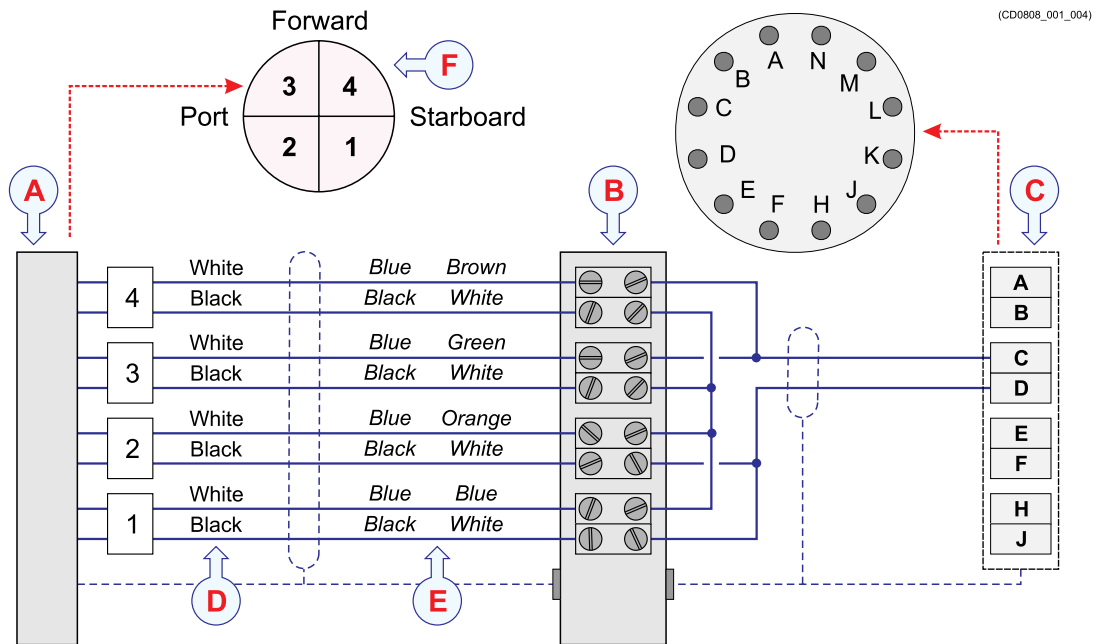

- A *Transducer*
- B *Optional junction box*
- C *GPT transducer connector*
- D *Colour codes on cables*
- E *Alternative colour codes on cables (mainly on old transducers)*
- F *Transducers segments (seen from top)*

The cable screen must be connected to the housing on the transducer plug. If a junction box is used to extend the cable, the screen must be connected to the cable glands on the box. The screen must not be connected to vessel ground.

If you need to splice the transducer cable, it is very important to use the correct cable. You must also avoid ground loops. We strongly recommend the use of a junction box. The junction box must be made of metal, it must be provided with proper cable glands, and its chassis must not be connected to vessel ground.

We strongly recommend that you install the transducer cable in a steel conduit.

Cable specifications

Not applicable. If you need an extension cable, contact your dealer – or Simrad – for advice.

Split beam transducer connection to a GPT Transducer socket wired for single beam high output

A split beam transducer can be connected as a single beam unit to sockets A through J on a GPT type transducer socket. This allows you to use the transducer as a single beam high power unit.

The other end of the cable is permanently fixed to the transducer.

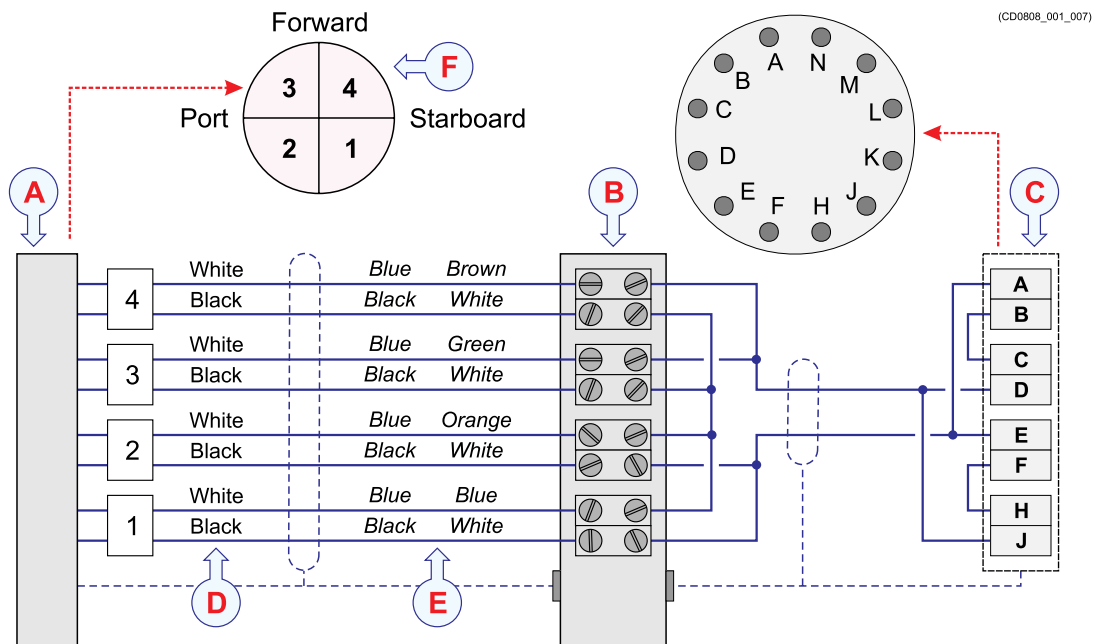

- A Transducer
- B Optional junction box
- C GPT transducer connector
- D Colour codes on cables
- E Alternative colour codes on cables (mainly on old transducers)
- F Transducers segments (seen from top)

The cable screen must be connected to the housing on the transducer plug. If a junction box is used to extend the cable, the screen must be connected to the cable glands on the box. The screen must not be connected to vessel ground.

If you need to splice the transducer cable, it is very important to use the correct cable. You must also avoid ground loops. We strongly recommend the use of a junction box. The junction box must be made of metal, it must be provided with proper cable glands, and its chassis must not be connected to vessel ground.

We strongly recommend that you install the transducer cable in a steel conduit.

Cable specifications

Not applicable. If you need an extension cable, contact your dealer – or Simrad – for advice.

Transducer 12-16/60 connection to a GPT Transducer socket

The Simrad12–16/60 dual beam transducer can be connected to sockets **C**, **D** and **N** on a GPT type transducer socket. This socket is used on the General Purpose Transceiver (GPT), and on some versions of the Wide Band Transceiver (WBT).

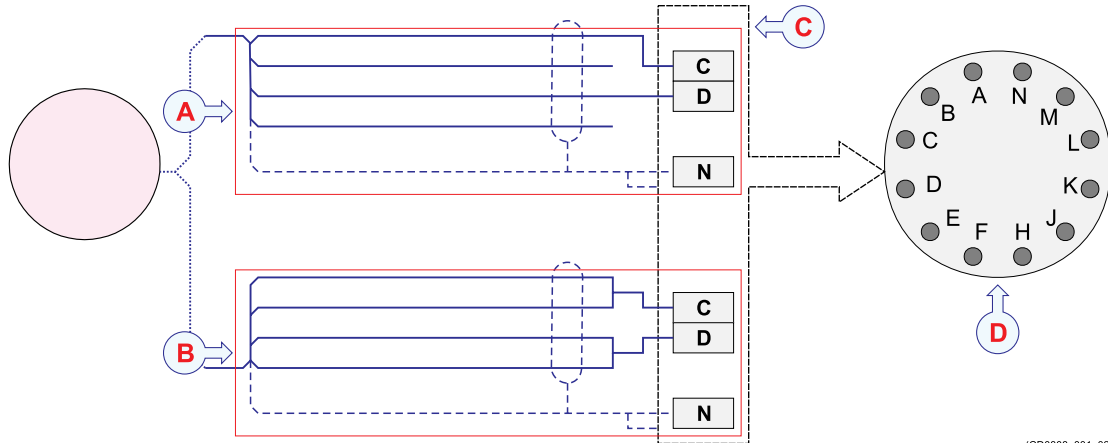

(CD0808_001_021)

- A** Use this wiring for wide beam
- B** Use this wiring for narrow beam
- C** Connectors on the GPT transducer socket (note that only C, D and N are used)
- D** GPT transducer socket seen from outside

Beam	Cable colours	Terminal on GPT socket
Wide	Brown	C
	Blue	—
	Yellow	D
	Black	—
Narrow	Brown	C
	Blue	—
	Yellow	D
	Black	—
Cable screen	Screen	N

The cable screen must be connected to the housing on the transducer plug and to terminal **N**. You must always install the transducer cable in a steel conduit.

If you need to splice the transducer cable, we strongly recommend the use of a metal junction box with proper cable glands. The cable screen must be connected to the cable glands. The cable screen and the junction box chassis must not be connected to vessel ground. Avoid ground loops. You must use the same type of cable as the original transducer cable, contact Kongsberg Maritime for advice.

Transducer ES18 connection to a GPT transducer socket

The ES18 transducer shall be connected to terminals A through J (plus N) on a GPT type transducer socket. This socket is used on the General Purpose Transceiver (GPT), and on some versions of the Wide Band Transceiver (WBT).

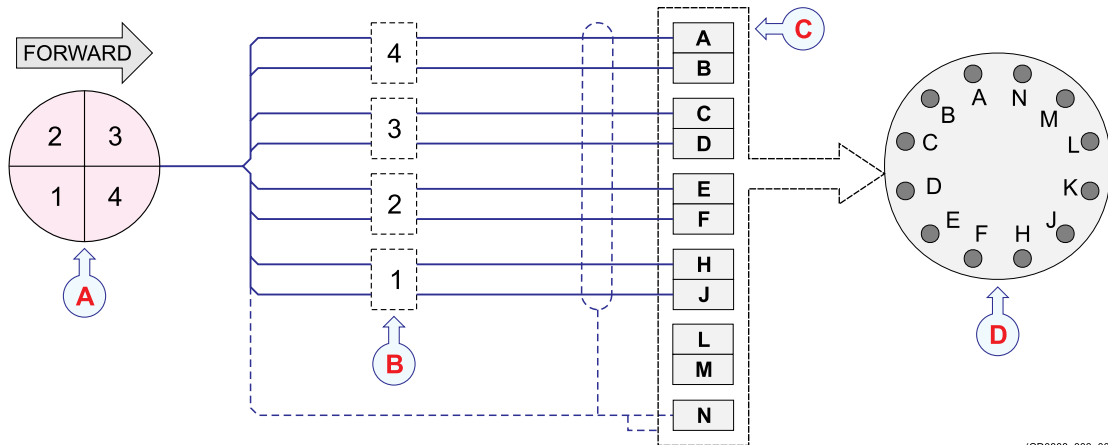

(CD0808_003_008)

- A *Transducer seen from top - observe the sector locations relative to the forward direction!*
- B *Sectors*
- C *Connectors on the GPT transducer socket*
- D *GPT transducer socket seen from outside*

Sector	Cable colours	Terminal on GPT socket
1	White	H
	Black	J
2	Green	E
	Black	F
3	Yellow	C
	Black	D
4	Blue	A
	Black	B
Cable screen	Screen	N

The cable screen must be connected to the housing on the transducer plug and to terminal N. You must always install the transducer cable in a steel conduit.

Note

The black wires in the transducer cable are not for grounding. You must never connect these together, and you must not connect any of them to vessel ground.

If you need to splice the transducer cable, we strongly recommend the use of a metal junction box with proper cable glands. The cable screen must be connected to the cable glands. The cable screen and the junction box chassis must not be connected to vessel ground. Avoid ground loops. You must use the same type of cable as the original transducer cable, contact Kongsberg Maritime for advice.

Transducer ES38-7 connection to a GPT transducer socket

The ES38-7 transducer shall be connected to terminals A through N on a GPT type transducer socket. This socket is used on the General Purpose Transceiver (GPT), and on some versions of the Wide Band Transceiver (WBT).

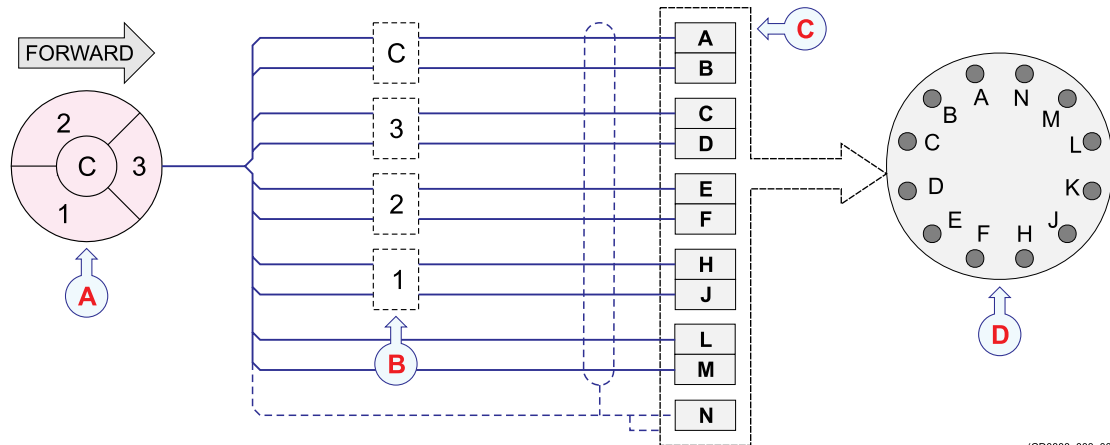

(CD0808_003_006)

- A *Transducer seen from top - observe the sector locations relative to the forward direction!*
- B *Sectors*
- C *Connectors on the GPT transducer socket*
- D *GPT transducer socket seen from outside*

Sector	Cable colours	Terminal on GPT socket
1	White	H
	Black	J
2	Green	E
	Black	F
3	Yellow	C
	Black	D
Centre	Blue	A
	Black	B
Digital output	Red	L
Digital ground	Black	M
Cable screen	Screen	N

The cable screen must be connected to the housing on the transducer plug and to terminal N. You must always install the transducer cable in a steel conduit.

Note

The black wires in the transducer cable are not for grounding. You must never connect these together, and you must not connect any of them to vessel ground.

If you need to splice the transducer cable, we strongly recommend the use of a metal junction box with proper cable glands. The cable screen must be connected to the cable glands. The cable screen and the junction box chassis must not be connected to vessel ground. Avoid ground loops. You must use the same type of cable as the original transducer cable, contact Kongsberg Maritime for advice.

Transducer ES38-10 connection to a GPT Transducer socket

The Simrad ES38-10 split beam transducer shall be connected to sockets C through J (and N) on a GPT type transducer socket. This socket is used on the General Purpose Transceiver (GPT), and on some versions of the Wide Band Transceiver (WBT).

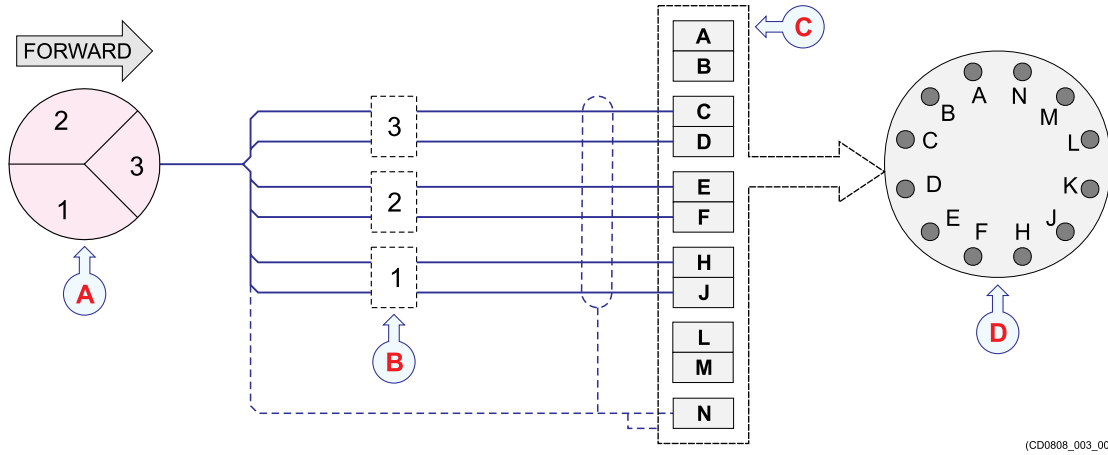

(CD0808_003_007)

- A *Transducer seen from top - observe the sector locations relative to the forward direction!*
- B *Sectors*
- C *Connectors on the GPT transducer socket*
- D *GPT transducer socket seen from outside*

Sector	Cable colours	Terminal on GPT socket
1	White	H
	Black	J
2	White	E
	Black	F
3	White	C
	Black	D
Cable screen	Screen	N

The cable screen must be connected to the housing on the transducer plug and to terminal N. You must always install the transducer cable in a steel conduit.

Note

The black wires in the transducer cable are not for grounding. You must never connect these together, and you must not connect any of them to vessel ground.

If you need to splice the transducer cable, we strongly recommend the use of a metal junction box with proper cable glands. The cable screen must be connected to the cable glands. The cable screen and the junction box chassis must not be connected to vessel ground. Avoid ground loops. You must use the same type of cable as the original transducer cable, contact Kongsberg Maritime for advice.

Transducer 38/200 Combi C connection to a GPT Transducer socket

The Simrad 38/200 Combi C transducer can be connected to sockets **C**, **D**, **H** and **J** on a GPT type transducer socket.

The other end of the cable is permanently fixed to the transducer.

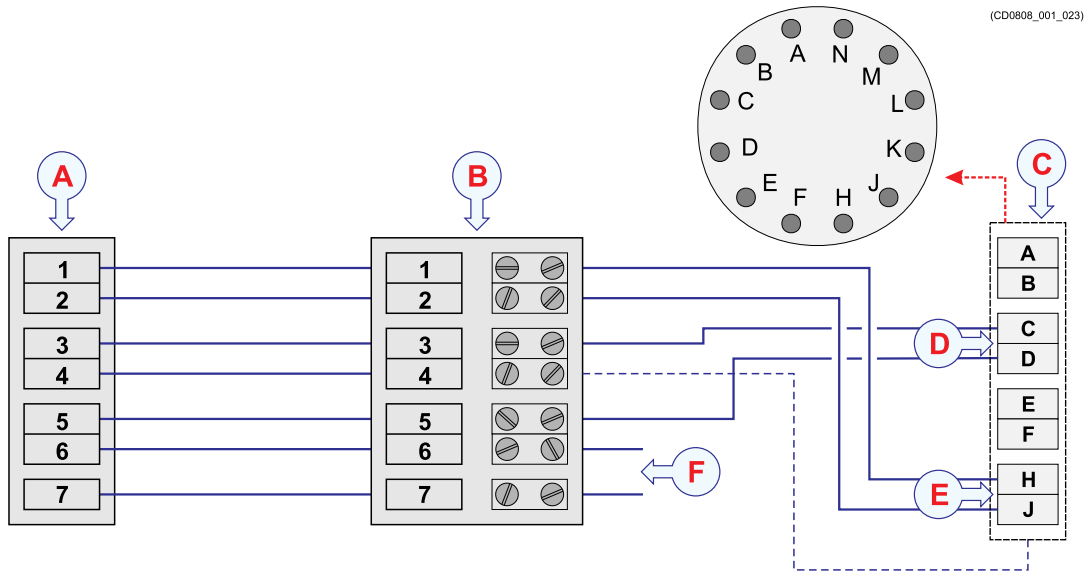

- A *Transducer – the cable is fitted with a 7-pin Mini-Con-X female plug*
- B *Optional junction box with a male 7-pin socket*
- C *GPT transducer connector*
- D *Low frequency element (38 kHz) is connected to sockets **C** and **D***
- E *High frequency element (200 kHz) is connected to sockets **H** and **J***
- F *Thermistor output*

The cable screen must be connected to the housing on the transducer plug. If a junction box is used to extend the cable, the screen must be connected to the cable glands on the box. The screen must not be connected to vessel ground.

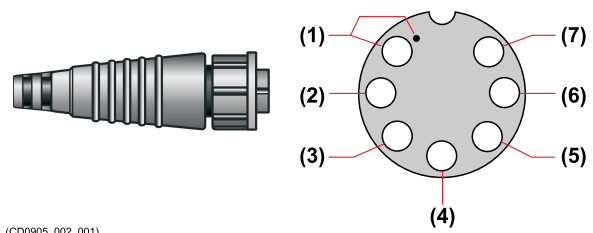

Note _____

The transducer cable must not be exposed to oil or other petroleum fluids!

Pins 6 and 7 on the transducer are connected to the thermistor that has been built into the transducer body.

The thermistor output wires must be connected to the relevant analogue input on your EK60 system.

The EK60 software does not support input from a temperature sensor.

Pin on transducer plug	Signal	Wire colour	Pin on GPT plug
1	200 kHz	Red	H
2	200 kHz	Black	J
3	38 kHz	Blue	C
4	Screen		Housing
5	38 kHz	White	D
6	Thermistor	Green	N/A
7	Thermistor	Yellow	N/A

If you need to splice the transducer cable, it is very important to use the correct cable. You must also avoid ground loops. We strongly recommend the use of a junction box. The junction box must be made of metal, it must be provided with proper cable glands, and its chassis must not be connected to vessel ground.

We strongly recommend that you install the transducer cable in a steel conduit.

Cable specifications

Not applicable. If you need an extension cable, contact your dealer – or Simrad – for advice.

Transducer ES38-18/200-18C connection to a GPT transducer socket

The ES38-18/200-18C transducer shall be connected to terminals A through N on a GPT type transducer socket. This socket is used on both the General Purpose Transceiver (GPT) and the Wide Band Transceiver (WBT) units.

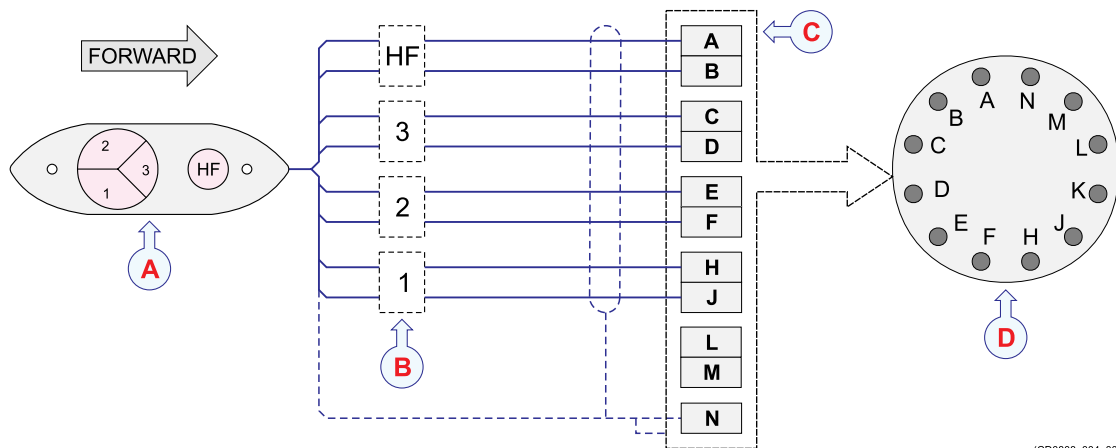

(CD0808_004_001)

- A *Transducer seen from top - observe the sector locations relative to the forward direction!*
- B *Sectors*
- C *Connectors on the GPT transducer socket*
- D *GPT transducer socket seen from outside*

Sector	Cable colours	Terminal on GPT socket
1	White	H
	Black	J
2	Green	E
	Black	F
3	Yellow	C
	Black	D
HF	Blue	A
	Black	B
Digital output	Red	L
Digital ground	Black	M
Cable screen	Screen	N

The cable screen must be connected to the housing on the transducer plug and to terminal N. You must always install the transducer cable in a steel conduit.

Note

The black wires in the transducer cable are not for grounding. You must never connect these together, and you must not connect any of them to vessel ground.

If you need to splice the transducer cable, we strongly recommend the use of a metal junction box with proper cable glands. The cable screen must be connected to the cable glands. The cable screen and the junction box chassis must not be connected to vessel ground. Avoid ground loops. You must use the same type of cable as the original transducer cable, contact Kongsberg Maritime for advice.

Transducer 50/200 Combi C connection to a GPT Transducer socket

The Simrad 50/200 Combi C transducer can be connected to sockets **C**, **D**, **H** and **J** on a GPT type transducer socket.

The other end of the cable is permanently fixed to the transducer.

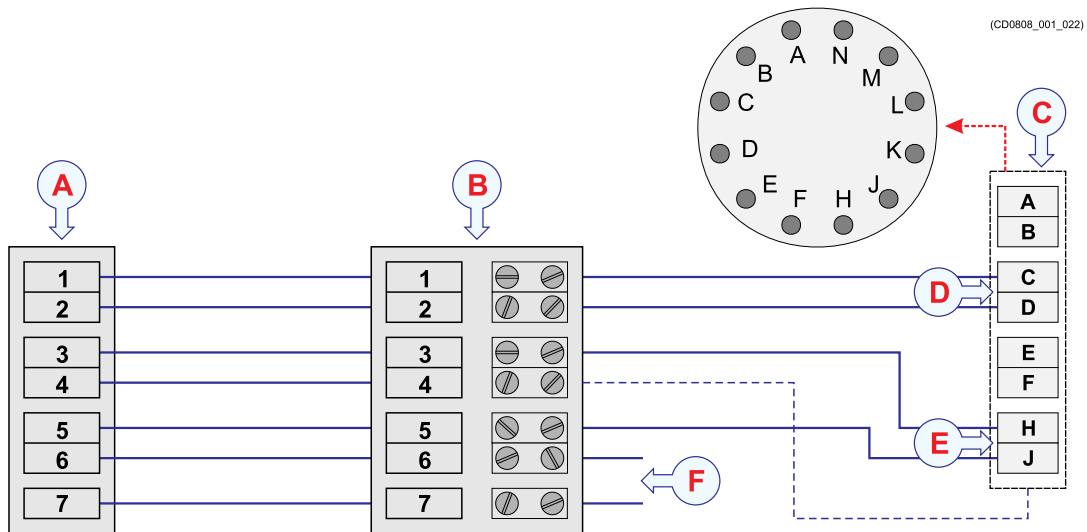

- A Transducer – the cable is fitted with a 7-pin Mini-Con-X female plug
- B Optional junction box with a male 7-pin socket
- C GPT transducer connector
- D Low frequency element (50 kHz) is connected to sockets **C** and **D**
- E High frequency element (200 kHz) is connected to sockets **H** and **J**
- F Thermistor output

The cable screen must be connected to the housing on the transducer plug. If a junction box is used to extend the cable, the screen must be connected to the cable glands on the box. The screen must not be connected to vessel ground.

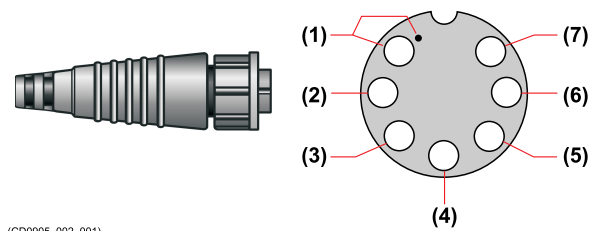

Note _____

The transducer cable must not be exposed to oil or other petroleum fluids!

Pins 6 and 7 on the transducer are connected to the thermistor that has been built into the transducer body.

The thermistor output wires must be connected to the relevant analogue input on your EK60 system.

The EK60 software does not support input from a temperature sensor.

Pin on transducer plug	Signal	Wire colour	Pin on GPT plug
1	50 kHz	Red	C
2	50 kHz	Black	D
3	200 kHz	Blue	H
4	Screen		Housing
5	200 kHz	White	J
6	Thermistor	Green	N/A
7	Thermistor	Yellow	N/A

If you need to splice the transducer cable, it is very important to use the correct cable. You must also avoid ground loops. We strongly recommend the use of a junction box. The junction box must be made of metal, it must be provided with proper cable glands, and its chassis must not be connected to vessel ground.

We strongly recommend that you install the transducer cable in a steel conduit.

Cable specifications

Not applicable. If you need an extension cable, contact your dealer – or Simrad – for advice.

Transducer ES70-18CD connection to a GPT Transducer socket

The ES70-18CD transducer is provided with an underwater plug. However, it may instead be connected to terminals A through N (plus N) on a GPT type transducer socket. This socket is used on both the General Purpose Transceiver (GPT) and the Wide Band Transceiver (WBT) units. To do this, you must cut the transducer cable to remove the plug, and use a junction box and an extension cable.

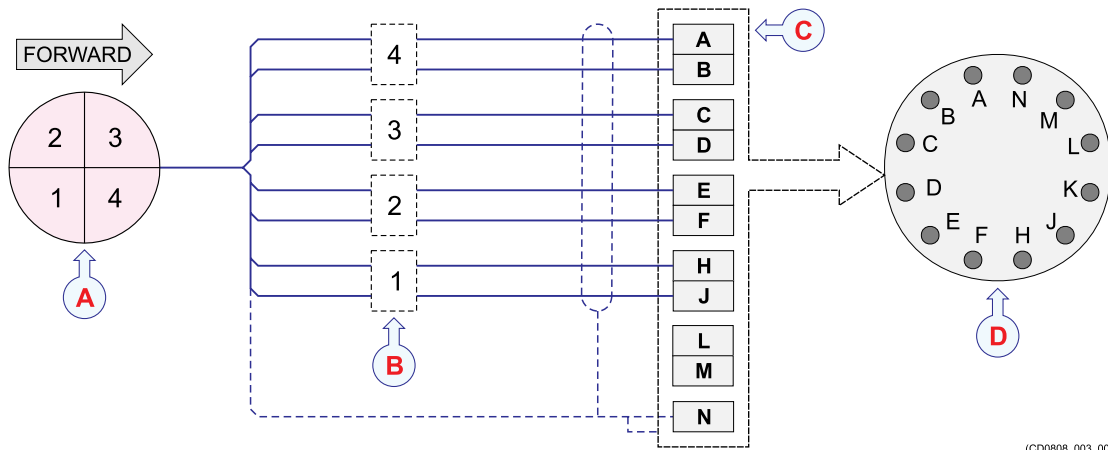

(CD0808_003_008)

- A *Transducer seen from top - observe the sector locations relative to the forward direction!*
- B *Sectors*
- C *Connectors on the GPT transducer socket*
- D *GPT transducer socket seen from outside*

Sector	Cable colours	Terminal on GPT socket
1	White	H
	Black	J
2	Green	E
	Black	F
3	Yellow	C
	Black	D
4	Blue	A
	Black	B
Cable screen	Screen	N

The cable screen must be connected to the housing on the transducer plug and to terminal N. You must always install the transducer cable in a steel conduit.

Note

The black wires in the transducer cable are not for grounding. You must never connect these together, and you must not connect any of them to vessel ground.

If you need to splice the transducer cable, we strongly recommend the use of a metal junction box with proper cable glands. The cable screen must be connected to the cable glands. The cable screen and the junction box chassis must not be connected to vessel ground. Avoid ground loops. You must use the same type of cable as the original transducer cable, contact Kongsberg Maritime for advice.

Burton underwater connectors on split beam transducers for deep water

A selection of the Simrad transducers have been designed to operate in deep water. These are intended for installation in subsea constructions, with autonomous transceivers, or inside a towed body.

Deep water transducers are fitted with only a short cable, and this is terminated in a female underwater connector. When the transducer is installed, the design of the subsea device must include a watertight junction box with the matched male panel socket. The transducer cable must then be fed from the junction box to the vessel or land station, or to a transceiver built into the subsea unit. Without a local transceiver, adequate protection must be provided to support the transducer cable.

Burton connector

The Burton connector used on the cable is an 8-pin Series 55.

The 5500 Series is an extremely rugged and reliable underwater electrical connector. It is the standard Burton connector series with pins in the receptacles and sockets in the plugs. The pin and socket relationship is due to the fact that in most applications, power runs from the plug into the receptacle. For safety reasons, it is desirable never to have power available on the pin side.

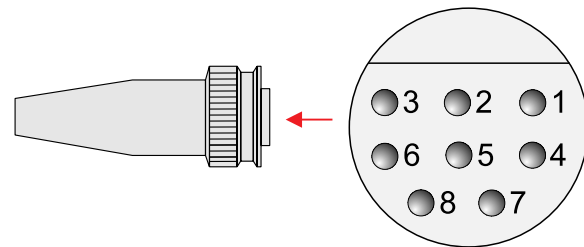

Burton subsea connectors, #CI-Subsea 102010, 2014

For more information about the Burton connectors, refer to the manufacturer's website.

- <http://www.cooperinterconnect.com>

Subsea female connector used on the cable

- Burton subsea female 8-pin connector (Series 55): **370-076837**
- True manufacturer's part number: **5501-2008-0005**

Suggested panel male connector

- Burton male panel 8-pin connector (with flange mount): **370-084169**
- True manufacturer's part number: **5506-2008-0004**

Pin configuration

Pin on Burton connector	Sector	Pin on GPT connector	Sector position
1	Sector 1 (+)	H	Aft starboard
4	Sector 1 (-)	J	
2	Sector 2 (+)	E	Aft port
5	Sector 2 (-)	F	
3	Sector 3 (+)	C	Fore port
6	Sector 3 (-)	D	
7	Sector 4 (+)	A	Fore starboard
8	Sector 4 (-)	B	

About serial lines

A preferred method to establish communication between the EK60 and peripheral devices, is by means of serial lines. Several serial line standards are available, each with different qualities.

Unless otherwise specified, the serial line cable must be provided by the installation shipyard.

RS-232 serial communication standard

An RS-232 serial port was once a standard feature of a personal computer, used for connections to modems, printers, mice, data storage, uninterruptible power supplies, and other peripheral devices. However, RS-232 is hampered by low transmission speed, large voltage swing, and large standard connectors. [...] Nevertheless, RS-232 devices are still used, especially in industrial machines, networking equipment and scientific instruments.

<https://en.wikipedia.org/wiki/RS-232> (September 2015)

Most RS-232 cables do not support all the signals in the standard RS-232 specification.

Important

When you are using RS-232 serial communication, observe that long runs of unshielded cable will pick up noise easily. This is because the RS-232 signals are not balanced.

Maximum length for an RS-232 serial cable is typically 60 meters with 2400 bps data rate, however this depends on the cable quality. Always check the cable manufacturers specifications for the actual "shunt capacitance". A common figure is 47.5 pF/m, which gives a maximum cable length of about 50 meters.

Note

Even though a standard exist for RS-232 pin configuration, certain manufacturer may still choose their own connector pins for the various signals used. In order to make the RS-232 connection to your peripheral device work properly, you must always consult the relevant instructions provided by the device manufacturer.

Fore more information about the RS-232 serial communication standard, see (for example):

- <https://en.wikipedia.org/wiki/RS-232>

RS-422 serial communication standard

While RS-232 is the most common serial interface for communicating with external devices using the NMEA standard, it only allows for one transmitter and one receiver on each line.

RS-422 provides a mechanism for transmitting data up to 10 Mbits/s. This interface format uses a balanced signal on two wires. This increases both the maximum baud

rate and the physical length of the cable, and it reduces the noise. With a high quality cable, you can use RS-422 on distances up to 1500 meters even in noisy environments. RS-422 is also specified for multi-drop applications. This means that one transmitter can send data to up to 10 receivers.

Note

There are no common standard for RS-422 pin configuration. Any manufacturer may choose their own connector pins for the various signals used. In order to make the RS-422 connection to your peripheral device work properly, you must always consult the relevant instructions provided by the device manufacturer.

For more information about the RS-422 serial communication standard, see (for example):

- <https://en.wikipedia.org/wiki/RS-422>

RS-485 serial communication standard

RS-485 (also known as TIA-485–A) is a standard defining the electrical characteristics of drivers and receivers for use in balanced digital multipoint systems. The standard is published by the Telecommunications Industry Association/Electronic Industries Alliance (TIA/EIA). Digital communications networks implementing the RS-485 standard can be used effectively over long distances and in electrically noisy environments. Multiple receivers may be connected to such a network in a linear, multi-drop configuration.

RS-485 offers data transmission speeds of 35 Mbit/s up to 10 m and 100 kbit/s at 1200 m. Since it uses a differential balanced line over twisted pair (like RS-422), it can span relatively large distances (typically up maximum 1200 m). In contrast to RS-422, which has a single driver circuit which cannot be switched off, RS-485 drivers need to be put in transmit mode explicitly by asserting a signal to the driver. This allows RS-485 to implement linear bus topologies using only two wires. The equipment located along a set of RS-485 wires are interchangeably called nodes, stations or devices.

RS-485, like RS-422, can be made full-duplex by using four wires. Since RS-485 is a multi-point specification, however, this is not necessary in many cases.

Note

There are no common standard for RS-485 pin configuration. Any manufacturer may choose their own connector pins for the various signals used. In order to make the RS-485 connection to your peripheral device work properly, you must always consult the relevant instructions provided by the device manufacturer.

For more information about the RS-485 serial communication standard, see (for example):

- <https://en.wikipedia.org/wiki/RS-485>

Related topics

[Generic RS-232 connection using three wires, page 84](#)

[Generic RS-232 connection using five wires, page 85](#)

[Generic RS-422 serial line using five wires, page 87](#)

[RS-232 used as synchronization trigger \(input or output\), page 86](#)

[Generic RS-485 connection using two or four wires, page 88](#)

[Moxa CP114EL-I Serial line adapter, page 89](#)

Basic cable requirements

It is very important that all systems cables are installed correctly. All cables must be properly supported and protected, and all relevant precautions must be made to prevent unwanted noise

Topics

[Cable trays, page 120](#)

[Radio frequency interference, page 121](#)

[Physical protection of cables, page 121](#)

[Grounding of system cables, page 121](#)

[Cable connections and terminations, page 122](#)

[Cable identification, page 122](#)

[Cable glands and termination procedures, page 123](#)

Cable trays

All permanently installed cables associated with the system must be supported and protected along their entire lengths using conduits and/or cable trays.

The only exception to this rule is over the final short distance (maximum. 0,5 meters) as the cables run into the cabinets/units to which they are connected. These short service loops are to allow the cabinets to move on their shock mounts, and to allow maintenance and repair.

- 1 Wherever possible, cable trays must be straight, accessible and placed so as to avoid possible contamination by condensation and dripping liquids (oil, etc.). They must be installed away from sources of heat, and must be protected against physical damage. Suitable shields must be provided where cables are installed in the vicinity of heat sources.
- 2 Unless it is absolutely unavoidable, cables should not be installed across the vessel's expansion joints. If the situation is unavoidable, a loop of cable having a length proportional to the possible expansion of the joint must be provided. The minimum internal radius of the loop must be at least twelve times the external diameter of the cable.
- 3 Where a service requires duplicate supply lines, the cables must follow separate paths through the vessel whenever possible.
- 4 Signal cables must not be installed in the same cable tray or conduit as high-power cables.
- 5 Cables containing insulation materials with different maximum-rated conductor temperatures should not be bunched together (that is, in a common clip, gland,

conduit or duct). When this is impractical, the cables must be carefully arranged such that the maximum temperature expected in any cable in the group is within the specifications of the lowest-rated cable.

- 6 Cables with protective coverings which may damage other cables should not be grouped with other cables.
- 7 Cables having a copper sheath or braiding must be installed in such a way that galvanic corrosion by contact with other metals is prevented.
- 8 To allow for future expansion of the system, all cables should be allocated spare conductor pairs. Also, space within the vessel should be set aside for the installation of extra cables.

Radio frequency interference

All cables that are to be permanently installed within 9 m (30 ft) of any source of Radio Frequency (RF) interference such as a transmitter aerial system or radio transmitters, must, unless shielded by a metal deck or bulkhead, be adequately screened

Suitable screening can be established using sheathing, braiding or other suitable material. In such a situation flexible cables should be screened wherever possible.

It is important that cables, other than those supplying services to the equipment installed in a radio room, are not installed through a radio room, high power switch gear or other potential sources of interference. Cables which must pass through a radio room must be screened by a continuous metal conduit which must be bonded to the screening of the radio room at its points of entry and exit.

Physical protection of cables

Cables exposed to the risk of physical damage must be enclosed in a steel conduit or protected by a metal casing unless the cable's covering (for example armour or sheath) is sufficient to protect it from the damage risk.

Cables exposed to an exceptional risk of mechanical damage (for example in holds, storage-spaces and cargo-spaces) must be protected by a suitable casing or conduit, even when armoured, if the cable covering does not guarantee sufficient protection for the cables.

Metallic materials used for the physical protection of cables must be suitably protected against corrosion.

Grounding of system cables

All metallic cable coverings (armour, metallic sheathing and other protection) must be electrically connected to the vessel's hull at both ends except in the case of final sub-circuits where they should be connected at the supply end only.

Grounding connections should be made using a conductor which has a cross-sectional area appropriate for the current rating of the cable, or with a metal clamp which grips the metallic covering of the cable and is bonded to the hull of the vessel. These cable coverings may also be grounded by means of glands specially intended for this purpose and designed to ensure a good ground connection. The glands used must be firmly attached to, and in good electrical contact with, a metal structure grounded in accordance with these recommendations.

Electrical continuity must be ensured along the entire length of all cable coverings, particularly at joints and splices. In no case should the shielding of cables be used as the only means of grounding cables or units.

Metallic casings, pipes and conduits must be grounded, and when fitted with joints these must be mechanically and electrically grounded locally.

Cable connections and terminations

All cable connections are shown on the applicable cable plan and/or interconnection diagrams.

Where the cable plan shows cable connections outside an equipment box outline, the connections are to be made to a plug or socket which matches the plug or socket on that particular item of equipment.

Where two cables are connected in series via a junction box or terminal block, the screens of both cables must be connected together, but not grounded.

Care must be taken to ensure that the correct terminations are used for all cable conductors, especially those that are to be connected to terminal blocks. In this case, crimped sleeve-terminations must be fitted to prevent the conductor core from fraying and making a bad connection with the terminal block. It is also of the utmost importance that where crimped terminations are used, the correct size of crimp and crimping tool are used. In addition, each cable conductor must have a minimum of 15 cm slack (service loop) left before its termination is fitted.

Cable identification

Cable identification codes corresponding to the cable number shown in the cable plan must be attached to each of the external cables.

The identification codes should be positioned on the cable in such a way that they are readily visible after all panels have been fitted.

In addition, each cable conductor should be marked with the terminal board number or socket to which it is connected.

Cable glands and termination procedures

Cable glands are used to attach and secure the end of a cable to the equipment. Cable glands may also be used for sealing cables passing through bulkheads or gland plates.

About cable glands

Cable glands are used whenever a cable passes through a watertight bulkhead or into a cabinet, to seal the opening through which the cable passes and to protect the cable from abrasion on the edges of the hole.

There are many different types of cable gland on the market. The cable glands are not supplied with the system.

Note

Even though the cabinets from Kongsberg Maritime may be prepared for specific types of cable glands, the installation shipyard will be responsible for selecting cable gland types and installing them.

A cable gland (in the U.S. more often known as a cable connector or fitting) is a device designed to attach and secure the end of a cable to the equipment. A cable gland provides strain-relief and connects by a means suitable for the type and description of cable for which it is designed—including provision for making electrical connection to the armour or braid and lead or aluminium sheath of the cable, if any. Cable glands may also be used for sealing cables passing through bulkheads or gland plates.

Cable glands are mechanical cable entry devices and can be constructed from metallic or non-metallic materials. They are used throughout a number of industries in conjunction with cable and wiring used in electrical instrumentation and automation systems.

Cable glands may be used on all types of electrical power, control, instrumentation, data and telecommunications cables. They are used as a sealing and termination device to ensure that the characteristics of the enclosure which the cable enters can be maintained adequately.

http://en.wikipedia.org/wiki/Cable_gland (February 2014)

Preparing cables for termination

Whenever a cable shall penetrate a cabinet or a bulkhead using a cable gland, the termination of the cable must be prepared.

Prerequisites

Electrical installations can only be done by certified electricians. All necessary tools and instruments required must be available. The installation shipyard must prepare detailed drawings of the electrical system, and identify each cable.

Context

Cable glands are used whenever a cable passes through a watertight bulkhead or into a cabinet, to seal the opening through which the cable passes and to protect the cable from abrasion on the edges of the hole. Follow the guidelines provided here when installing cables through cable glands.

Important

There are many different types of cable gland on the market. This procedure describes the types used (now and previously) as standard in the units manufactured by Kongsberg Maritime. The cable glands are not supplied with the system.

Even though the cabinets from Kongsberg Maritime may be prepared for specific types, the installation shipyard will be responsible for selecting cable gland types and installing them.

Procedure

- 1 Ensure all the cables to be connected are completely isolated from any power sources.

For safety reasons, switch off and remove the power supply fuses from any units or systems into which the cables are already connected.

- 2 Select the cable to be connected into the cabinet, and select the cable gland through which the cable is to pass.

Note

A minimum of 5 cm (recommended 5 - 10 cm) of slack cable must be allowed, both inside and outside the cabinet, when installing cables. This is to allow for vibration damping, maintenance and measurement errors. Always double-check your measurements before taking any irreversible actions.

- 3 Depending on whether the cable has previously been installed in conduits:
 - a If the cable has already been installed in conduits, measure the maximum length of cable required to reach from the final cable clip outside the cabinet to the terminal blocks inside the cabinet, add 20 cm, then remove the excess cable.
 - b If the cable has not been installed in conduits, measure the maximum length of wire required to reach from the cable gland to the terminal blocks inside the cabinet, add 20 cm, and mark the cable.

Note

The cable's outer insulation will extend into the cable gland to a point approximately 5 mm outside the outer surface of the cabinet wall into which the cable gland is secured.

- 4 Carefully remove the outer insulation from the required cable length.
Be careful to avoid damage to the screening!
- 5 Leaving an appropriate length of the screen exposed from the insulation, cut off the remainder.

Securing and terminating cables

Once a cable has been prepared for termination, it must be connected to a unit or cabinet.

Prerequisites

Electrical installations can only be done by certified electricians. All necessary tools and instruments required must be available. The installation shipyard must prepare detailed drawings of the electrical system, and identify each cable.

Context

Observe the relevant cable plan and/or interconnection drawing(s) for the product.

Procedure

- 1 Referring to the wiring diagram and ensuring that there is 5 to 10 cm slack cable inside the cabinet, prepare and connect the cable cores to the appropriate terminals and/or plugs within or onto the cabinet.
- 2 Secure the cable using cable clips.
- 3 Check the terminal connections against the wiring diagram to ensure they are correct. Follow the same procedure for all the cables and cable glands.
- 4 Check the cabinet to ensure all tools and rubbish are removed, then close the cabinet door.
- 5 Take the appropriate safety measures, then replace the fuses and apply power to the system.
- 6 Perform a relevant system test to ensure the installation has been made successfully.

Using multi-diameter cable sealing

Cable sealing systems are available from several manufacturers, and multi-diameter types are becoming increasingly popular due to their ease of use.

Prerequisites

Electrical installations can only be done by certified electricians. All necessary tools and instruments required must be available. The installation shipyard must prepare detailed drawings of the electrical system, and identify each cable.

Context

Only a brief description of the sealing system will be presented here. Further information with relevant technical specifications and installation descriptions must be obtained from the manufacturer.



Roxtec modules (Image from Roxtec website)

The illustrations and examples here are provided by the following manufacturer:

Roxtec International AB
Box 540
S-371 23 Karlskrona, SWEDEN

- <http://www.roxtec.com>



Sealing system example; the finished assembly

The Roxtec system is available with a large number of various modules and compression units. It will also comply with screening and EMC requirements.

Procedure

- 1 Cut an opening in the structure (bulkhead, cabinet etc) you wish to penetrate.

The hole must be sized to fit one of the standard rectangular or circular frames provided by the sealing system manufacturer.

Note

The chosen solution must comply with the fire and/or pressure demands for the vessel.

If the sealing is to be used under water, both pressure and material requirements must be taken into consideration.

- 2 Mount the frame.
- 3 Pull the cable(s) through the frame.
In most cases the opening will be large enough to accept the plugs on the cables.
- 4 Secure each cable with a square sealing module.
- 5 Adjust the module to fit the cable's outer diameter.
- 6 When the required number of modules are installed, tighten the assembly with a compression unit.

Further requirements

For more information, and other installation procedures, refer to the documentation provided by Roxtec (or your manufacturer of choice).

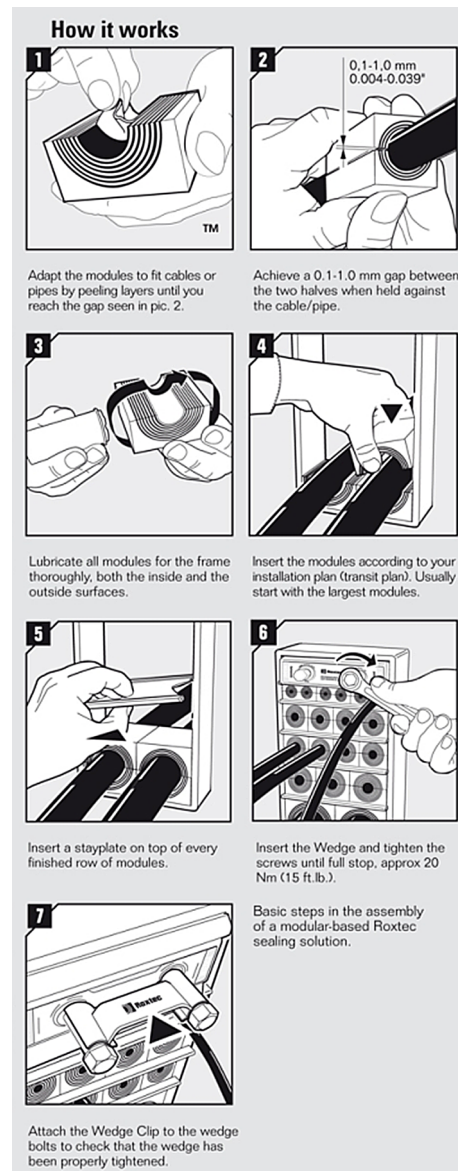

Roxtec steps (Image from Roxtec website)

Setting up the interfaces to peripheral devices

Topics

[About NMEA and standard datagram formats, page 129](#)

[Interfacing peripheral equipment, page 132](#)

[Synchronization with other hydroacoustic systems, page 145](#)

About NMEA and standard datagram formats

The majority of the datagrams used by the EK60 are defined by the National Marine Electronics Association (NMEA).

Topics

[About the NMEA datagram formats, page 129](#)

[National Marine Electronics Association \(NMEA\), page 129](#)

[NMEA sentence structure, page 130](#)

[Standard NMEA 0183 communications parameters, page 131](#)

About the NMEA datagram formats

The EK60 can send and receive information to and from several different peripherals. All transmissions take place as **datagrams** with data sentences. Each datagram has a defined format and length.

The NMEA 0183 standard is the most common protocol used to receive and transmit data to and from peripheral sensors. A parametric sentence structure is used for all NMEA data.

The sentence start with a "\$" delimiter, and represent the majority of approved sentences defined by the standard. This sentence structure, with delimited and defined data files, is the preferred method for conveying information.

For more information about the NMEA standard, the format and the data sentences, refer to their official publications. Their document *NMEA 1083 - Standard for interfacing marine electronic devices* explains the formats in detail. The document can be obtained from NMEA.

Note

Two phrases are in general use to describe basic transfer unit associated with a packet-switched network; "telegram" and "datagram". In this publication, we use the phrase "datagram".

National Marine Electronics Association (NMEA)

The National Marine Electronics Association (NMEA) has defined communication standards for maritime electronic equipment, and the EK60 Scientific Echo Sounder supports these standards for communication with external sensors and peripheral systems.

The most common standard is the NMEA 0183. The National Marine Electronics Association describes it as follows:

The NMEA 0183 Interface Standard defines electrical signal requirements, data transmission protocol and time, and specific sentence formats for a 4800 baud serial data bus. Each bus may have only one talker but many listeners.

National Marine Electronics Association

For more information about the National Marine Electronics Association and the NMEA 0183 standard, refer to the organization's web site at:

- <http://www.nmea.org>

NMEA sentence structure

A defines sentence structure is defined by NMEA to establish the communication between two units. Most other datagram formats are designed using the same, or a similar, structure.

The following provides a summary explanation of the approved parametric sentence structure.

```
$aacc,c-c*hh<CR><LF>
```

1 "\$"

This character (Hex: 24) is used to identify the start of the sentence.

2 "aacc"

This is the address field. The first two characters (aa) identifies the *talker ID*, while the last three characters are the *sentence formatter* mnemonic code identifying the data type and the string format of the successive fields.

3 ","

The comma (Hex: 2C) is used as *field delimiter*. This character starts each field except the address and checksum fields. If it is followed by a null field, it is all that remains to indicate no data in the field.

4 "c-c"

This is the *data sentence block*. This is a series of data fields containing all the data to be transmitted. The data field sentence is fixed and identified by the sentence formatter in the address field. Data fields may be of variable lengths, and they are preceded by the field delimiter.

5 "*"

This character (Hex: 2A) is the *checksum delimiter*. This delimiter follows the last field of the sentence, and indicates that the following two alphanumerical characters contain the checksum.

6 "hh"

This is the *checksum*.

7 <CR><LF>

The carriage return and line feed characters terminates the sentence.

Note

In some proprietary telegrams received from other Kongsberg Maritime equipment, the \$ character is replaced by the @ character. The checksum field may then not be in use.

Standard NMEA 0183 communications parameters

NMEA defines a fixed set of transmission parameters.

The communication parameters defined for **NMEA 0183** are:

- **Baudrate:** 4800 bits per second
- **Data bits:** 8
- **Parity:** None
- **Stop bits:** One

Some instruments may offer other parameters and/or choices. You must always check the relevant documentation provided by the manufacturer.

Interfacing peripheral equipment

Topics

- [Setting up the Ethernet data output, page 132](#)
- [Setting up the input from a motion sensor, page 133](#)
- [Setting up the input from a trawl system, page 134](#)
- [Setting up the input from a catch monitoring system, page 135](#)
- [Setting up the input from a navigation system, page 136](#)
- [Setting up a serial line annotation input, page 139](#)
- [Setting up depth output to an external system, page 140](#)
- [Setting up depth output to a Simrad sonar, page 142](#)

Setting up the Ethernet data output

The EK60 can communicate with an external network devices that can benefit from the echo data. This communication is controlled by the **Ethernet Output** dialog box.

Prerequisites

This procedures assumes that you are familiar with Ethernet communication, IP addresses and the relevant User Datagram Protocol (UDP) parameters.

Context

Through Ethernet, the EK60 can communicate with an peripheral devices that can benefit from the processed data. This Ethernet communication is controlled by the **Ethernet Output** dialog box. Note that this interface will require the absolute identity of the remote UDP port and the remote IP address.

Procedure

- 1 Connect the EK60 to the peripheral system using the Ethernet interface.

Note

It is very important that a high quality Ethernet cable is used. You must use CAT-5E quality or better. Cables with lower bandwidth capacity will reduce the EK60 performance.

- 2 Click **Output**→**Ethernet**.
Observe that the **Ethernet Output** dialog box opens.
- 3 Define the **Remote Port**.

- 4 Define the **Remote IP Address** for the computer you wish to export the information to.
- 5 Set **Communication Mode** to *Broadcast*.
- 6 In the **Ethernet Output** dialog box, click **EK500 Datagram**.
Observe that the **EK500 Datagram** dialog box opens.
 - a On the **Datagram** tab, define which datagrams you wish to export.
 - b Click **OK** to save the chosen parameters and close the dialog box.
 - c Observe that you are returned to the **Ethernet Output** dialog box.
- 7 Click **OK** to save the chosen parameters and close the dialog box.

Setting up the input from a motion sensor

The information from a motion sensor (normally heave, roll and pitch) can be imported into the EK60 to increase the accuracy of the echo sounder data.

Prerequisites

This procedure assumes that:

- You have a vacant interface port on your Processor Unit.
- You are familiar with NMEA and other relevant datagram formats.
- You know how to set up the parameters for serial and local area network (LAN) communication.

Context

The heave information is used in the bottom depth estimation, and also for display and output of echogram data. Display of roll and pitch information can be useful when replaying previously recorded data files.

Note that heave information can be monitored on the **Status bar**.

If you choose to use the analogue input on a General Purpose Transceiver (GPT), the **Setup** button allows you to open a dedicated dialog box to control the sensitivity and offset. If the **Setup** button is unavailable, click **Normal**→**Normal Operation** to activate the transceiver.

The EK60 supports the following datagram formats from a motion sensor.

- Sounder/TSS1 (Proprietary Kongsberg Maritime motion protocol)
- EM1000 (Proprietary Kongsberg Maritime motion protocol)
- EM3000 (Proprietary Kongsberg Maritime motion protocol)

Procedure

- 1 Connect the motion sensor system to an available communication port on your Processor Unit.
This is described in the *Cable layout and interconnections* chapter.
- 2 Click **Install**→**Motion**
Observe that the **Motion** dialog box opens.
- 3 Set up the interface.
 - a Select the Ethernet or serial port you wish to use.
 - b Choose which protocol (datagram) you wish to receive.
 - c If you are using a serial line, define the baud rate.
- 4 Click **OK** to save the chosen parameters and close the dialog box.

Setting up the input from a trawl system

By interfacing a trawl system, you can import relevant information about your deployed trawl, and show it in the EK60 presentation.

Prerequisites

To set up this interface, the external trawl system must be operational, and the relevant datagram export must be enabled.

This procedure assumes that:

- You have a vacant interface port on your Processor Unit.
- You are familiar with NMEA and other relevant datagram formats.
- You know how to set up the parameters for serial and local area network (LAN) communication.

Context

Communication with external trawl systems (for example Simrad ITI, Simrad FS70 or Simrad FX80) is based on NMEA and proprietary telegrams.

The EK60 supports the following datagram formats from a trawl system.

- ITI
- Ifremer

Procedure

- 1 Connect the peripheral system to an available communication port on your Processor Unit.
This is described in the *Cable layout and interconnections* chapter.

- 2 Click **Install**→**Trawl**

Observe that the **Trawl** dialog box opens.

- 3 Set up the interface.

- a Select the Ethernet or serial port you wish to use.
- b Choose which external system to receive data from.
- c Set up the relevant port parameters.

The communication parameters defined for **NMEA 0183** are:

- **Baudrate:** 4800 bits per second
- **Data bits:** 8
- **Parity:** None
- **Stop bits:** One

Some instruments may offer other parameters and/or choices. You must always check the relevant documentation provided by the manufacturer.

- d Click **OK** to save the chosen parameters and close the dialog box.

- 4 Click **OK** to save the chosen parameters and close the dialog box.

Setting up the input from a catch monitoring system

By interfacing a catch monitoring system, you can import relevant information about your deployed gear, and show it in the EK60 presentation.

Prerequisites

To set up this interface, the external catch monitoring system must be operational, and the relevant datagram export must be enabled.

This procedure assumes that:

- You have a vacant interface port on your Processor Unit.
- You are familiar with NMEA and other relevant datagram formats.
- You know how to set up the parameters for serial and local area network (LAN) communication.

Context

Communication with external catch monitoring systems (for example Simrad PI44, Simrad PI54 or Simrad PI50) is based on NMEA and proprietary telegrams.

The EK60 supports the following datagram format from a catch monitoring system.

- PSIMP-D PI Sensor data (Kongsberg Maritime proprietary format)

Procedure

- 1 Connect the peripheral system to an available communication port on your Processor Unit.

This is described in the *Cable layout and interconnections* chapter.

- 2 Click **Install**→**Trawl**

Observe that the **Trawl** dialog box opens.

- 3 Set up the interface.

- a Select the Ethernet or serial port you wish to use.
- b Choose which external system to receive data from.
- c Set up the relevant port parameters.

The communication parameters defined for **NMEA 0183** are:

- **Baudrate:** 4800 bits per second
- **Data bits:** 8
- **Parity:** None
- **Stop bits:** One

Some instruments may offer other parameters and/or choices. You must always check the relevant documentation provided by the manufacturer.

- d Click **OK** to save the chosen parameters and close the dialog box.

- 4 Click **OK** to save the chosen parameters and close the dialog box.

Setting up the input from a navigation system

In order to read navigational data (position, speed, distance and heading) from an external sensor, you must choose which interface port to use, and then which datagram(s) to read.

Prerequisites

This procedure assumes that:

- You have a vacant interface port on your Processor Unit.
- You are familiar with NMEA and other relevant datagram formats.
- You know how to set up the parameters for serial and local area network (LAN) communication.

Context

Most Global Positioning System (GPS) receivers provide NMEA 0183 telegrams containing speed, sailed distance as well as geographical latitude and longitude information. Some GPS systems will also provide the current heading, but this information is normally taken from the gyro.

The EK60 supports the following datagram formats for position information.

- **Auto**

The EK60 will read all relevant datagrams. If the specified information is provided to the system on more than one datagram format, a built-in priority list will be used.

- **GGA**

This NMEA datagram format contains time, position and fix related data from a global positioning system (GPS).

- **GLL**

This NMEA datagram format is used to transfer latitude and longitude of vessel position, time of position fix, and status from a global positioning system (GPS).

- **RMC**

This NMEA datagram format contains time, date, position, course and speed data provided by a global navigation satellite system (GNSS) receiver.

The EK60 supports the following datagram formats for speed information.

- **Auto**

The EK60 will read all relevant datagrams. If the specified information is provided to the system on more than one datagram format, a built-in priority list will be used.

- **VBW Dual ground and water speed**

- **VTG**

This NMEA datagram format contains the actual course and speed relative to the ground.

- **RMC**

This NMEA datagram format contains time, date, position, course and speed data provided by a global navigation satellite system (GNSS) receiver.

The EK60 supports the following datagram format for vessel distance information.

- **VLW**

This NMEA datagram format contains the distance travelled relative to the water and over the ground.

The EK60 supports the following datagram formats for vessel heading information.

- **Auto**

The EK60 will read all relevant datagrams. If the specified information is provided to the system on more than one datagram format, a built-in priority list will be used.

- **HDG**

This NMEA datagram format contains the heading from a magnetic sensor, which if corrected for deviation will produce magnetic heading, which if offset by variation will provide true heading.

- **HDM**

This NMEA datagram format contains vessel heading in degrees magnetic.

- **HDT**

This NMEA datagram format is used to transfer heading information from a gyro.

- **VHW**

This NMEA datagram format contains the compass heading to which the vessel points and the speed of the vessel relative to the water.

Procedure

- 1 Connect the navigation system to an available communication port on your Processor Unit.

This is described in the *Cable layout and interconnections* chapter.
- 2 Click **Install**→**Navigation**,
Observe that the **Navigation** dialog box opens.
- 3 Set up the position data you wish to receive.
 - a Click the **Position** tab.
 - b Select the Ethernet or serial port you wish to use.
 - c Click **Setup** to define the communication parameters for the selected port.
 - d Select which NMEA sentence you wish to receive.

If you choose *Auto*, the EK60 will automatically choose among the incoming telegrams according to a predefined priority list.
 - e If applicable, define the **Talker ID**.

If your EK60 is not equipped with a keyboard, click the "keyboard" button to open an on-screen keyboard.
- 4 Set up the speed data you wish to receive.
 - a Click the **Speed** tab.
 - b Select the Ethernet or serial port you wish to use.
 - c Click **Setup** to define the communication parameters for the selected port.
 - d Select which NMEA sentence you wish to receive.

If you choose *Auto*, the EK60 will automatically choose among the incoming telegrams according to a predefined priority list.
 - e If applicable, define the **Talker ID**.

If your EK60 is not equipped with a keyboard, click the "keyboard" button to open an on-screen keyboard.
 - f If you wish to define a manual speed, select **Manual Speed** and use **Speed [kts]** to choose the value.

- 5 Set up the distance data you wish to receive.
 - a Click the **Distance** tab.
 - b Choose from which source you wish to receive the distance information.
 - c Select the Ethernet or serial port you wish to use.
 - d Click **Setup** to define the communication parameters for the selected port.
 - e Select which NMEA sentence you wish to receive (currently only VLW may be chosen).
 - f If applicable, define the **Talker ID**.

If your EK60 is not equipped with a keyboard, click the "keyboard" button to open an on-screen keyboard.
 - g If you wish to define a manual distance, use **Distance [nmi]** to choose the value.
- 6 Set up the heading data you wish to receive.
 - a Click the **Heading** tab.
 - b Select the Ethernet or serial port you wish to use.
 - c Click **Setup** to define the communication parameters for the selected port.
 - d Select which NMEA sentence you wish to receive.

If you choose *Auto*, the EK60 will automatically choose among the incoming telegrams according to a predefined priority list.
 - e If applicable, define the **Talker ID**.

If your EK60 is not equipped with a keyboard, click the "keyboard" button to open an on-screen keyboard.
- 7 Click **OK** to save the chosen parameters and close the dialog box.

Setting up a serial line annotation input

Several different annotation types may be added to the echogram. You can add these manually, or import information as datagrams using a communication port.

Prerequisites

This procedure assumes that:

- You have a vacant interface port on your Processor Unit.
- You are familiar with NMEA and other relevant datagram formats.
- You know how to set up the parameters for serial and local area network (LAN) communication.

Context

The data communication from an external annotation source is based on a proprietary data format.

The EK60 supports the following datagram format for annotations.

- **ATS**

This is a proprietary format developed by Kongsberg Maritime for use with annotations

Procedure

- 1 Connect the peripheral system providing the annotations to an available communication port on your Processor Unit.

This is described in the *Cable layout and interconnections* chapter.

- 2 Click **Install**→**Annotation**

Observe that the **Annotation** dialog box opens.

- 3 In the **Annotations** dialog box, click **Port** to select which communication port to use for the interface.

- 4 Click **Setup** to define the communication parameters for the chosen port.

The communication parameters defined for **NMEA 0183** are:

- **Baudrate:** 4800 bits per second
- **Data bits:** 8
- **Parity:** None
- **Stop bits:** One

Some instruments may offer other parameters and/or choices. You must always check the relevant documentation provided by the manufacturer.

- 5 Click **OK** to save the chosen parameters and close the dialog box.

Setting up depth output to an external system

The depth output from the EK60 can be exported to a peripheral system.

Prerequisites

This procedure assumes that:

- You have a vacant interface port on your Processor Unit.
- You are familiar with NMEA and other relevant datagram formats.
- You know how to set up the parameters for serial and local area network (LAN) communication.

Context

The current depth from a defined transceiver channel can be sent out on a serial line to an external system.

The data is exported on standard NMEA datagram formats and/or on proprietary formats.

The EK60 supports the following datagram formats for depth output.

- **DBS**

This NMEA datagram format provides the current depth from the surface. The datagram is no longer recommended for use in new designs.

- **DBT**

This NMEA datagram format provides the water depth referenced to the transducer.

- **DPT**

This NMEA datagram format contains water depth relative to the transducer and offset of the measuring transducer.

- **Simrad**

This is the proprietary "EK500 Depth" datagram format created by Kongsberg Maritime to contain depth data.

- **PSIMDHB**

This proprietary datagram format created by Simrad contains the bottom hardness and biomass as calculated by an echo sounder.

- **Atlas**

This is a third party proprietary datagram format for depth information. It was created by Atlas Elektronik (<https://www.atlas-elektronik.com>) for use with their echo sounders.

Procedure

- 1 Connect the peripheral system to an available communication port on your Processor Unit.

This is described in the *Cable layout and interconnections* chapter.

- 2 Click **Output**→**Depth**.

Observe that the **Depth Output** dialog box opens.

- 3 In the **Depth Output** dialog box, click **Add** to establish a new output.

- 4 Set up the depth output port.

- a Select which communication port to use.

- b For the selected port, click **Setup** to define the communication parameters.

The communication parameters defined for **NMEA 0183** are:

- **Baudrate:** 4800 bits per second
- **Data bits:** 8
- **Parity:** None
- **Stop bits:** One

Some instruments may offer other parameters and/or choices. You must always check the relevant documentation provided by the manufacturer.

- c Select which datagram to send.
- d If applicable, define the **Talker ID**.
- e Select which transceiver and frequency you wish to export the depth information from.

Tip _____

In most cases, the lowest frequency is used.

- 5 Click **OK** to save the chosen parameters and close the dialog box.

Setting up depth output to a Simrad sonar

The depth output from the EK60 can be exported to a Simrad sonar system.

Prerequisites

This procedure assumes that:

- You have a vacant interface port on your Processor Unit.
- You are familiar with NMEA and other relevant datagram formats.
- You know how to set up the parameters for serial and local area network (LAN) communication.

Context

The current depth from a defined transceiver channel can be sent out on a serial line to a sonar system.

Note _____

For this output, you can only use an existing serial line that is already set up to accept input from an other peripheral system.

Note that the depth information is normally also provided on the duplex interfaces to trawl instrumentation and catch monitoring systems.

One or more of the following serial lines can be used:

- Heave sensor interface
- Navigation interface
- Trawl interface

The EK60 supports the following datagram formats for depth output.

- **DBS**

This NMEA datagram format provides the current depth from the surface. The datagram is no longer recommended for use in new designs.

- **DBT**

This NMEA datagram format provides the water depth referenced to the transducer.

- **DPT**

This NMEA datagram format contains water depth relative to the transducer and offset of the measuring transducer.

- **Simrad**

This is the proprietary "EK500 Depth" datagram format created by Kongsberg Maritime to contain depth data.

- **PSIMDHB**

This proprietary datagram format created by Simrad contains the bottom hardness and biomass as calculated by an echo sounder.

- **Atlas**

This is a third party proprietary datagram format for depth information. It was created by Atlas Elektronik (<https://www.atlas-elektronik.com>) for use with their echo sounders.

Procedure

- 1 Connect the sonar system to an available communication port on your Processor Unit.
This is described in the *Cable layout and interconnections* chapter.
- 2 Click **Output**→**Depth**.
Observe that the **Depth Output** dialog box opens.
- 3 In the **Depth Output** dialog box, click **Add** to establish a new output.
- 4 Set up the depth output port.
 - a Select which communication port to use.

- b For the selected port, click **Setup** to define the communication parameters.

The communication parameters defined for **NMEA 0183** are:

- **Baudrate:** 4800 bits per second
- **Data bits:** 8
- **Parity:** None
- **Stop bits:** One

Some instruments may offer other parameters and/or choices. You must always check the relevant documentation provided by the manufacturer.

- c Select which datagram to send.
- d If applicable, define the **Talker ID**.
- e Select which transceiver and frequency you wish to export the depth information from.

Tip _____

In most cases, the lowest frequency is used.

- 5 Click **OK** to save the chosen parameters and close the dialog box.

Synchronization with other hydroacoustic systems

Topics

[About synchronization, page 145](#)

[Synchronization using a serial line, page 146](#)

[Synchronization using the Auxiliary plug, page 147](#)

[EK60 set up in *Slave* mode, page 148](#)

[EK60 set up in *Master* mode, page 149](#)

About synchronization

Whenever more than one hydroacoustic system (for example echo sounder or sonar) is installed on a vessel, interference may occur. To avoid this, the relevant systems may either be connected to a common synchronisation system, or one of the hydroacoustic systems may be set up to control the transmissions.

In principles, there are three synchronisation modes:

1 **None**

The EK60 runs by itself, no synchronisation takes place.

2 **Slave**

The EK60 can be interfaced as a *Slave* to an external *Master* synchronisation device. This external device may be any other hydroacoustic system (for example an echo sounder or sonar), or even a dedicated synchronisation system.

3 **Master**

The EK60 can be set into *Master* mode. It will then control when the slave system(s) can transmit.

In its default configuration, the EK60 is set up to operate as a *Master*. Special action must be taken to redefine the EK60 for *Master* or *Slave* operation. This is made in the **Operation** dialog box by selecting **External triggering**.

The EK60 system may comprise more than one General Purpose Transceiver (GPT). If the EK60 operates as a *Master*, the synchronization between these is controlled by the echo sounder software.

If the EK60 operates as a *Slave* system, the transceivers must be individually controlled by the *Master* system.

On large hydroacoustic systems, the best solution for synchronisation will always be a dedicated synchronisation system, such as the Kongsberg K-Sync system.

The K-Sync synchronisation system provides highly configurable transmission control when multiple hydroacoustic systems are employed on a vessel. The K-Sync provides simple yet flexible control of the transmission schedule. The triggering can be tailored to the particular type of vessel operation, and the desired data density collected by each system.

Any hydroacoustic system that has a trigger input can be externally triggered by the K-Sync.

Synchronization using a serial line

In many applications, the synchronisation interface is based on an RS-232 serial port. Only the **Clear to Send (CTS)** and **Request to Send (RTS)** connections of the RS-232 interface are then used.

According to the standard specifications for RS-232, an output must generate a voltage level of +5 to +15 Vdc (logic "low"), and -5 to -15 Vdc (logic "high") into a load of 3 to 7 kΩ. An RS-232 receiver must present a 3 to 7 kΩ load, converting an input of +3 to +25 Vdc to logic "low", and an input of +3 to +25 Vdc to logic "high".

With a positive trigger pulse, the offset voltage does not have any significance. Even small variations (flutter) over and below 0 Vdc will not trigger the interface.

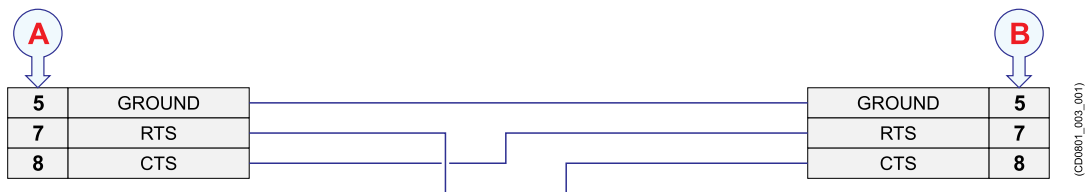

- A *Local connection*
- B *Connection on peripheral device*
- C *Female 9-pin D-connector*
- D *Male 9-pin D-connector*

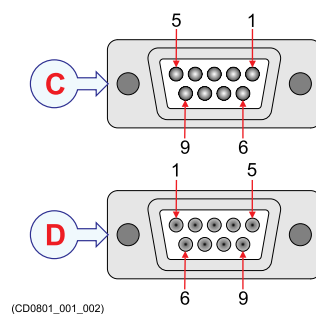

RS-422 serial interfaces can also be used for synchronization purposes. In RS-422, the voltage levels are +6 Vdc and -6 Vdc. The positive voltage is logic "low". In general use, the advantage of RS-422 is the speed and maximum range. The same pins (5, 7 and 8 on a 9-pin D-connector) are used for synchronization.

Important

When you use RS-422 you must keep in mind that the shift from logic "low" to logic "high" happens at 0 Vdc. Your offset voltage must therefore be negative to prevent small variations (flutter) over and below 0 Vdc to trigger the interface.

Synchronization using the Auxiliary plug

The General Purpose Transceiver (GPT) is equipped with an auxiliary socket, and this interface device supports trigger pulses. Dedicated circuitry in the General Purpose Transceiver (GPT) provides the input and output triggering.

Digital input

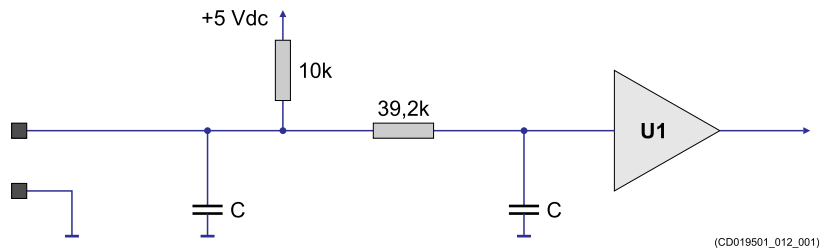

This digital input circuitry is valid for the following interfaces: **TrigIn+**, **TrigIn-**, **Event** and **Log**.

The **Event** and **Log** interfaces are not supported by the EK60 software.

Digital output

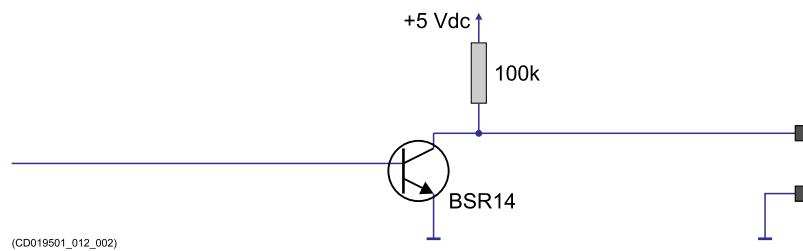

This digital output circuitry is valid for the following interfaces: **TrigOut+**, **TrigOut-** and **Alarm**.

Note

The current that can be drawn from this open collector circuitry is limited to 100 mA.

The **Alarm** interfaces is not supported by the EK60 software.

Differential input

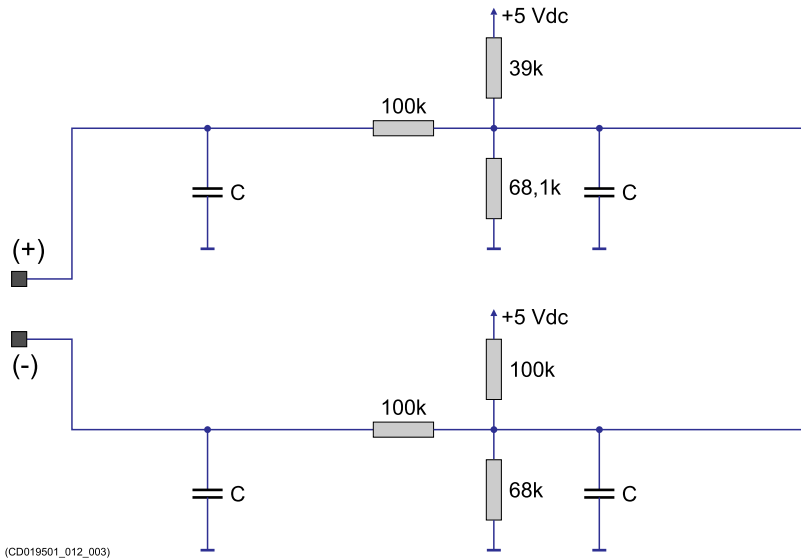

This differential input circuitry is valid for the following interfaces: **Heave, Pitch and Roll.**

Note

Maximum differential input range is ± 10 Vdc.

The **Heave, Pitch and Roll** interfaces are not supported by the EK60 software.

EK60 set up in *Slave* mode

In *Slave* mode, the EK60 triggers on a positive edge from the external system (level exceeds +3 Vdc) on **Clear to Send (CTS)** (pin 8).

Using a serial line

In order to synchronize the EK60 with older Simrad sonars, you must use a serial line on each end. The EK60 serial line must then be connected to a serial line on the sonar.

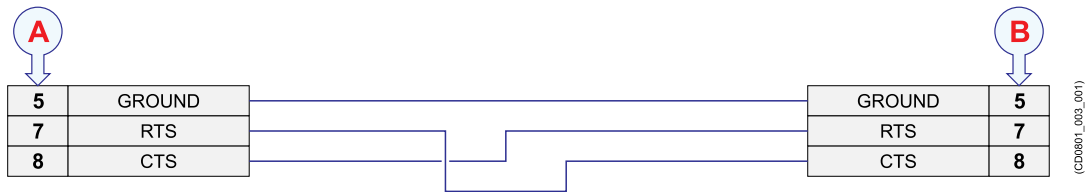

- A Local connection
- B Connection on peripheral device
- C Female 9-pin D-connector
- D Male 9-pin D-connector

On the EK60 Processor Unit, RTS (pin 7) goes logical "low" (typically +10 Vdc) approximately 2 to 3 ms prior to transmitting, and returns to logical "high" (typically -10 Vdc) when the EK60 has finished sampling the echo data.

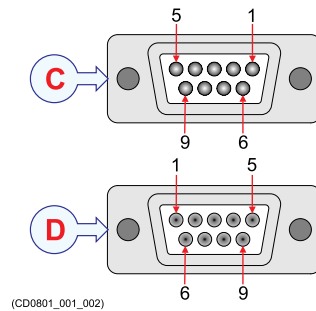

Note

On EK60 software versions prior to 2.2.0, pin 7 on the echo sounder must not be connected when the EK60 runs in Slave mode.

Using the GPT Auxiliary plug

If an external system is used to provide the transmit trigger, the trigger signal must be connected to one of the **TrigIn** inputs on the Auxiliary plug. When activated, the trigger signal from the external system will allow the EK60 system to transmit.

If more than one General Purpose Transceiver (GPT) is used by the *Slave* system, the input trigger must be connected to all the transceivers in parallel.

Two **TrigIn** inputs are available for either positive or negative triggering. The **TrigIn**-input is sensitive to a high-to-low transition.

Connect the ground wire to one of the **Ground** pins (18-22) on the Auxiliary plug.

EK60 set up in *Master* mode

If you have one *Master* system to control two slaves, you must connect a single cable (plus ground) from the **Request to Send (RTS)** output on the *Master* system to the **Clear to Send (CTS)** input on both slaves. The return from the **Request to Send (RTS)** outputs on the slaves must not be connected.

Using a serial line

The Master controls the **Request to Send (RTS)** and receives acknowledge on the **Clear to Send (CTS)**.

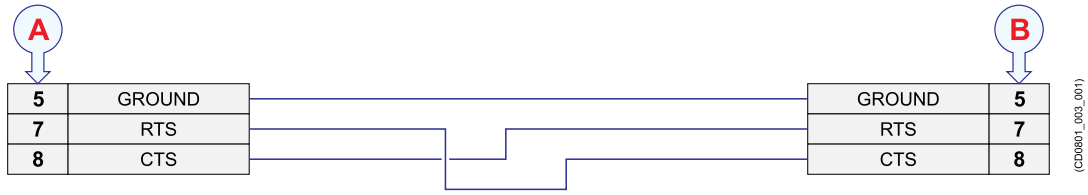

- A Local connection
- B Connection on peripheral device
- C Female 9-pin D-connector
- D Male 9-pin D-connector

The *Slave* is controlled by the **Clear to Send (CTS)** pin and sends acknowledge on the **Request to Send (RTS)** pin. So the **Request to Send (RTS)** on the *Master* side is connected to the **Clear to Send (CTS)** on the *Slave* side, and the **Clear to Send (CTS)** on the *Master* side is connected to the **Request to Send (RTS)** on the *Slave* side.

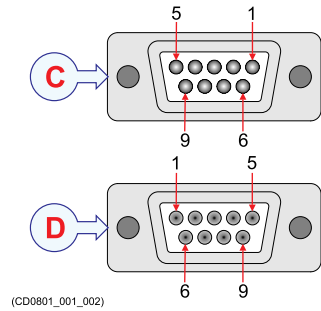

Note

On EK60 software versions prior to 2.2.0, pin 7 on the echo sounder must not be connected when the EK60 runs in Slave mode.

Using the GPT Auxiliary plug

If an external system is used to provide the transmit trigger, the trigger signal must be connected to one of the **TrigIn** inputs on the Auxiliary connector. When activated, the trigger signal from the external system will allow the EK60 system to transmit.

If more than one General Purpose Transceiver (GPT) is used by the *Slave* system, the input trigger must be connected to all the transceivers in parallel.

Two **TrigIn** inputs are available for either positive or negative triggering. The **TrigIn**-input is sensitive to a high-to-low transition.

Connect the ground wire to one of the **Ground** pins (18-22) on the Auxiliary plug.

Setting to work

Topics

[Setting to work summary, page 152](#)

[Verifying that the EK60 is ready for operational use, page 153](#)

[Powering up the EK60 for the first time, page 160](#)

[System test procedures, page 165](#)

[Installation remarks, page 166](#)

Setting to work summary

Once all the hardware units have been installed, and all the cables have been connected, the EK60 can be powered up for the first time, and set to work.

Prerequisites

- All EK60 hardware units have been installed according to the relevant instructions.
- All system cables have been installed.
- All connections have been made.
- All operating power is available.
- All peripheral devices that shall communicate with the EK60 are available and operational.
- All relevant personnel and tools are available.

Procedure

- 1 Verify that the EK60 is ready for operational use.
 - a Verify that all hardware have been installed correctly.
 - b Verify that all cables have been connected correctly.
- 2 Power up the EK60 for the first time.
 - a Install the EK60 software.
 - b Define the IP address on the Ethernet adapter.
 - c Install transducer(s) and frequency channel(s).
- 3 Set up the interfaces to peripheral devices.

To provide correct information, the EK60 needs to communicate with external devices. All these interfaces must be set up in the EK60 software.
- 4 Test the EK60 operational functionality.

To verify that the EK60 fulfills all operational and functional requirements, specific tests are required.
- 5 Create a backup with the EK60 configuration and software installation.

Once all EK60 configuration and testing have been finalized, it is good practice to back up the configuration data and software installation.
- 6 Fill in and sign the installation approval document, and return it to Simrad.

Verifying that the EK60 is ready for operational use

Topics

[Verifying that operational power is correct, page 153](#)

[Verifying that all cables are properly connected, page 154](#)

[Visual inspection of the display, page 154](#)

[Visual inspection of the Processor Unit, page 157](#)

[Visual inspection of the General Purpose Transceiver \(GPT\), page 158](#)

Verifying that operational power is correct

The EK60 operates on AC power from the vessel's mains supply. Before you can apply AC power up any EK60 unit, you must verify the power is correct.

Prerequisites

- All EK60 hardware units have been installed according to the relevant instructions.
- All system cables have been installed.
- All connections have been made.
- All operating power is available.
- All relevant personnel (ships electrician) and tools (for example a voltmeter) are available.

Procedure

- 1 For each EK60 unit that operates on AC mains:
 - a Verify that the unit is connected to AC mains.
 - b Measure the voltage and the frequency in the power outlet, and make sure that the relevant EK60 unit can operate on this power.
 - c Verify that the circuit breaker on the power circuit can handle the load when the EK60 is powered up.
- 2 If irregularities are found, write these down in the in the *Installation remarks* table.

Verifying that all cables are properly connected

The EK60 relies on communication between each system unit, and between the EK60 and external devices. It is very important that all cables are correctly installed, that the proper cable types have been used, and that all cables are connected correctly.

Prerequisites

- All EK60 hardware units have been installed according to the relevant instructions.
- All system cables have been installed.
- All connections have been made.
- All operating power is available.
- All relevant personnel (ships electrician) and tools (for example multimeter and cable tester) are available.

For this procedure you will also need a qualification tester with the ability to test the quality and bandwidth of Ethernet cables.

Context

All cabling is described in the *Cable layout and interconnections* chapter. Refer to the cable plan, the cable list and the basic cable requirements.

Procedure

- 1 For each cable that is in used on the EK60:
 - a Verify that the cable has been installed.
 - b Verify that the connections made at each end of the cable are correct.
 - c Verify that the cable has been installed as instructed in the basic cable requirements.

Pay special attention to signal cables. These must not be installed too close to power cables.
 - d Use a multimeter or a dedicated cable tester to check the continuity in each cable.
- 2 Use a qualification tester to verify that each Ethernet cable is correctly wired, and meets the specifications related to quality and bandwidth.
- 3 If irregularities are found, write these down in the in the *Installation remarks* table.

Visual inspection of the display

A visual inspection of the EK60 display is required to verify that the unit has not been physically damaged during the installation.

Prerequisites

This procedure assumes that the EK60 system has been installed as specified in the EK60 *Installation manual*.

No specific tools or instruments are required for this test.

Context

The display shall be new, clean and free from scratches, dents or other physical damage. It shall be clearly identified with a product label.

Observe the installation shipyard's procedures for workmanship, installation of physical units, and installation and termination of cables.

Note

This test procedure is only used when the display is provided by Simrad as a part of the EK60 delivery.

Procedure

- 1 Check that the display is installed in the correct location, and that it is suitably orientated with respect to ambient light conditions and reflections.
- 2 Check that the structure to which the display is fastened is substantial enough to hold the unit securely under all operating conditions.

If the display is secured to a table or shelf, check that it is bolted or welded securely to the deck and/or bulkhead.
- 3 Check that the unit is securely connected to the ship's ground with an earthing strap.

The strap must be in addition to any incidental electrical contact made by the mounting lugs on the unit.
- 4 Use a standard multimeter to check that the resistance between the unit and the ship's ground is approximately 0 (zero) Ω .
- 5 Check the physical installation of the unit.
 - a Check that the bolts, screws or studs holding the unit are of the correct size.
 - b Check that the correct flat and shake-proof washers have been used.
 - c Check that all nuts have been tightened properly.
- 6 Check that all welds and brackets have been painted with the correct preservation medium to prevent corrosion.
- 7 Check that all cables leading to the unit have been properly mounted and secured.
- 8 Verify that enough slack has been provided on the cables to allow maintenance and replacement.
- 9 Check that the unit is not physically damaged, and that the paint-work is clean.

The physical handling of the unit during the installation may have caused some scratches to the paint-work. This can be accepted. However, if rough handling has caused serious damage to the unit, this must be recorded with a written statement and necessary photos, so that corrective actions can be made.

- 10 If irregularities are found, write these down in the in the *Installation remarks* table.

Visual inspection of the Processor Unit

A visual inspection of the EK60 Processor Unit is required to verify that the unit has not been physically damaged during the installation.

Prerequisites

This procedure assumes that the EK60 system has been installed as specified in the EK60 *Installation manual*.

No specific tools or instruments are required for this test.

Context

The Processor Unit shall be new, clean and free from scratches, dents or other physical damage. It shall be clearly identified with a product label.

Observe the installation shipyard's procedures for workmanship, installation of physical units, and installation and termination of cables.

Note

This test procedure is only used when the Processor Unit is provided by Simrad as a part of the EK60 delivery.

Procedure

- 1 Check that the Processor Unit is installed in the correct location, and that it is suitably oriented for replacement and cabling.
- 2 Check that you have free access to rear and front side connectors on the Processor Unit for maintenance purposes.
- 3 Check that ample space is provided to open/close DVD and/or CD lids, and to insert and remove USB memory devices.
- 4 If the unit is installed inside a rack or a closed compartment, check that ample ventilation is provided to avoid overheating.
- 5 Check that the unit is securely connected to the ship's ground with an earthing strap.
The strap must be in addition to any incidental electrical contact made by the mounting lugs on the unit.
- 6 Use a standard multimeter to check that the resistance between the unit and the ship's ground is approximately 0 (zero) Ω .
- 7 Check the physical installation of the unit.
 - a Check that the bolts, screws or studs holding the unit are of the correct size.
 - b Check that the correct flat and shake-proof washers have been used.
 - c Check that all nuts have been tightened properly.
- 8 Check that all welds and brackets have been painted with the correct preservation medium to prevent corrosion.

- 9 Check that all cables leading to the unit have been properly mounted and secured.
- 10 Verify that enough slack has been provided on the cables to allow maintenance and replacement.
- 11 Check that the unit is not physically damaged, and that the paint-work is clean.
The physical handling of the unit during the installation may have caused some scratches to the paint-work. This can be accepted. However, if rough handling has caused serious damage to the unit, this must be recorded with a written statement and necessary photos, so that corrective actions can be made.
- 12 Verify that the unit's serial number has been recorded in the list of hardware items.

Visual inspection of the General Purpose Transceiver (GPT)

A visual inspection of each EK60 General Purpose Transceiver (GPT) is required to verify that the units have not been physically damaged during the installation.

Prerequisites

This procedure assumes that the EK60 system has been set up with its hardware units connected as specified in the EK60 *Installation manual*.

No specific tools or instruments are required for this test.

Context

The transceiver shall be new, clean and free from scratches, dents or other physical damage. It shall be clearly identified with a product label.

Observe the installation shipyard's procedures for workmanship, installation of physical units, and installation and termination of cables.

Note

The steps in this procedure must be repeated for each General Purpose Transceiver (GPT) that have been installed.

Procedure

- 1 Check that the General Purpose Transceiver (GPT) is installed in the correct location, and that it is suitably oriented for easy maintenance and replacement of parts.
- 2 Check that you have free access to all the connectors on the transceiver for maintenance purposes.
- 3 Check that the unit is securely connected to the ship's ground with an earthing strap.
The strap must be in addition to any incidental electrical contact made by the mounting lugs on the unit.

- 4 Use a standard multimeter to check that the resistance between the unit and the ship's ground is approximately 0 (zero) Ω .
- 5 Check the physical installation of the unit.
 - a Check that the bolts, screws or studs holding the unit are of the correct size.
 - b Check that the correct flat and shake-proof washers have been used.
 - c Check that all nuts have been tightened properly.
- 6 Check that all welds and brackets have been painted with the correct preservation medium to prevent corrosion.
- 7 Check that all cables leading to the unit have been properly mounted and secured.
- 8 Verify that enough slack has been provided on the cables to allow maintenance and replacement.
- 9 Check that the unit is not physically damaged, and that the paint-work is clean.

The physical handling of the unit during the installation may have caused some scratches to the paint-work. This can be accepted. However, if rough handling has caused serious damage to the unit, this must be recorded with a written statement and necessary photos, so that corrective actions can be made.
- 10 If irregularities are found, write these down in the in the *Installation remarks* table.

Powering up the EK60 for the first time

Topics

[Setting up summary, page 160](#)

[Installing the EK60 operational software, page 161](#)

[Defining the IP address on the Processor Unit network adapter for communication with the General Purpose Transceiver \(GPT\), page 162](#)

[Installing transceiver channels, page 163](#)

[Adjusting the screen resolution, page 164](#)

Setting up summary

Before a new EK60 Scientific Echo Sounder can be put to use, it must be set up for operation. You must install the software, and configure transducer(s) and transceiver(s).

Prerequisites

- The EK60 Scientific Echo Sounder system units have all been installed according to the instructions provided.
- All power and interface cables and connections have been connected and verified.
- All system units have been inspected.
- The EK60 operational software is available.

Caution

You must never power up the EK60 when the ship is in dry dock. The transducer will be damaged if it transmits in open air.

Procedure

- 1 Do the following preparations:
 - a Power up the Processor Unit.
 - b Verify that you have administrative rights.
 - c Switch off any firewall applications.
 - d Open the operating systems's *Network and Sharing Center*, and set the IP address for the network adapter used to communicate with the transceiver.
IP Address: **157.237.15.12**
Subnet mask: **255.255.255.0**
- 2 Install the EK60 operational software.

- 3 Power up the transceiver(s).
- 4 Verify that the Processor Unit is connected to the transceiver(s) using the Ethernet cable specified in the EK60 *Installation manual*.

If you use more than one transceiver, a high performance Ethernet switch must be used.

Note _____

It is very important that high quality Ethernet cables are used. You must use CAT-5E STP (Shielded Twisted Pair) quality or better. Cables with lower bandwidth capacity will reduce the EK60 performance. Do not connect the Processor Unit to the transceiver(s) using the vessel's existing local area network.

- 5 Start the EK60.
- 6 Click **Install**→**Transceiver**
- 7 Install the frequency channel(s).
 - a In the **Transceiver Installation** dialog box, select **Browse**.
The EK60 will automatically search the network for transceivers.
 - b Observe that all the available frequency channels are listed at the top of the dialog box.
 - c Select a frequency channel that is available, and choose the correct transducer.

Note _____

This is a critical task. You must ensure that the correct transducer is selected. If you connect the transceiver to a transducer that can not handle the power rating, it may be damaged beyond repair.

- 8 Click **OK** to save the chosen parameters and close the dialog box.
- 9 Set up the interfaces to peripheral navigation sensors.
- 10 Start normal operation

Note _____

To obtain quantitative data, the EK60 must be calibrated.

Observe the description in the EK60 Reference manual and on-line help.

Installing the EK60 operational software

If your EK60 Scientific Echo Sounder is provided with a Processor Unit, the EK60 software has already been installed. However, if you intend to use your own computer, you must install the software yourself.

Prerequisites

In order to install the EK60 operational software, you need the relevant file set on a suitable media. This can be a CD, a DVD or a USB flash drive.

If the EK60 software is provided on a CD or a DVD, and your computer is not fitted with a suitable drive, copy the files to a USB flash drive.

Note

You need administrative rights on the Processor Unit to install the EK60 software.

If you are using the EK60 system with your own computer, verify that this computer meets the technical requirements before you install the software.

Procedure

- 1 Power up the Processor Unit (computer), and allow the operating system to start.
- 2 Insert the EK60 software media.
- 3 Use a file manager application on the computer to access the software files.
- 4 Double-click on the `Setup.exe` file to start the installation.
- 5 Allow the installation wizard to run. Follow the instructions provided.

We recommend that you install the EK60 in the default folder suggested by the wizard.

- 6 Once the installation has been completed, double-click the EK60 icon on the desktop to start the program.
- 7 Depending on your operating system parameters, certain dialog boxes may open.
 - a Observe that Windows 7 Firewall may open a dialog box requesting information about the network. Select **Public**, and click **Allow access**.
 - b The operating system may also open other dialog boxes to verify that the EK60 software can run on the computer. You must of course permit this.

Defining the IP address on the Processor Unit network adapter for communication with the General Purpose Transceiver (GPT)

The communication between the Processor Unit and the transceiver(s) is made using a high speed Ethernet cable. If more than one transceiver is used, an Ethernet switch is added. In order to communicate, you recommend that define which IP Address and Subnet mask the Ethernet adapter in the Processor Unit shall use for this communication.

Prerequisites

This procedure is made for the Microsoft® Windows® 7 operating system. It is assumed that you are familiar with this operating system.

Context

As long as you do not change the Processor Unit to an other computer, or replace the network adapter in your Processor Unit, you will only need to do this once.

Procedure

- 1 On the Processor Unit, stop the EK60 program.
- 2 Locate the operating system dialog box.
 - a Click **Start**→**Control Panel**→**Network and Sharing Center**.
 - b On the left hand menu, select **Change adapter settings**.
 - c Click once on the network adapter to select it, then left-click and select **Properties** on the short-cut menu.
 - d On the list of connections, click **Internet Protocol 4 (TCP/IPv4)**, and then **Properties**.
- 3 Select **Use the following IP address**, and type the IP address and network mask.
IP Address: **157.237.15.12**
Subnet mask: **255.255.255.0**
- 4 Click **OK** to save the settings, then close all the dialog boxes.

Further requirements

If you later need to change the IP address, always restart the transceiver before you start the EK60.

Installing transceiver channels

In order to use the EK60 the Processor Unit must be connected to one or more transceivers, and each of these must in turn be connected to one or more transducers. This transceiver/transducer-combination is referred to as a "channel". Each channel must be installed before it can be put to use.

Prerequisites

This procedure assumes that:

- The EK60 installation is complete with all cables connected.
- The transceiver has been powered up.
- The Ethernet adapter in the Processor Unit has been set up with a unique IP address.

Context

The **Transceiver Installation** dialog box controls the installation and disconnection of transceivers. Every time this dialog box is opened, the EK60 software automatically performs a search on the Ethernet network for transceivers.

The phrase frequency channel is used to identify the combination of a transceiver, transducers and the frequencies offered.

The frequency channel list in the upper part of the **Transceiver Installation** dialog box provides you with an overview of the frequency channels currently available.

If you have many transceivers connected you can change the size of the dialog box, or you can use the two arrows on the right hand side of the list to scroll up and down.

- Entries shown in **black** are detected frequency channels which are not installed, but available for installation.
- Entries shown in **green** are detected frequency channels, which are both detected and installed.
- Entries shown in **blue** are detected frequency channels which are installed by another echo sounder program, and thus not available for this application.
- Entries shown in **red** are frequency channels which have previously been installed, but are no longer available.

Procedure

- 1 Click **Install**→**Transceiver**
- 2 Install the frequency channel(s).
 - a In the **Transceiver Installation** dialog box, select **Browse**.

The EK60 will automatically search the network for transceivers.
 - b Observe that all the available frequency channels are listed at the top of the dialog box.
 - c Select a frequency channel that is available, and choose the correct transducer.

Note

This is a critical task. You must ensure that the correct transducer is selected. If you connect the transceiver to a transducer that can not handle the power rating, it may be damaged beyond repair.

- 3 Click **OK** to save the chosen parameters and close the dialog box.

Adjusting the screen resolution

If you purchase the Simrad EK60 Scientific Echo Sounder with a "Enix" Processor Unit, you will see that the default screen resolution on the computer has been set to 1280 x 1024 pixels. We recommend that you use a higher resolution than this.

Prerequisites

This procedure is made for the Microsoft® Windows® 7 operating system. It is assumed that you are familiar with this operating system.

Context

As a general recommendation, you should set the screen resolution as high as possible. This will allow you more "space" in the EK60 presentation to offer more detailed information. The physical length of your top bar will also be extended, and free space for icons and navigational information.

As long as you do not change the Processor Unit to an other computer, replace the graphic adapter in your Processor Unit or the physical display, you will only need to do this once.

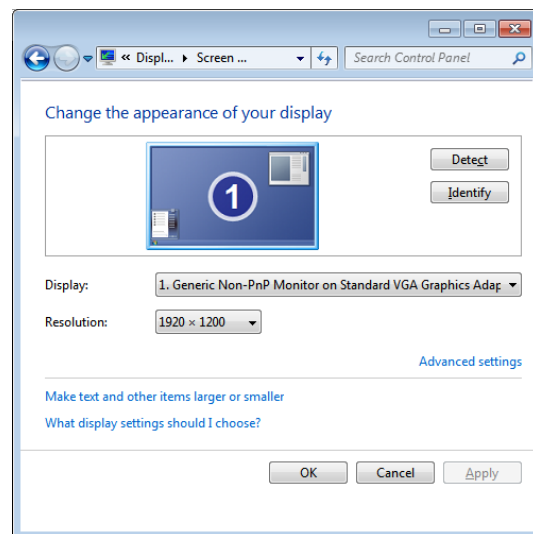

Procedure

- 1 On the Processor Unit, stop the EK60 program.
- 2 In the bottom left corner of your computer desktop, click the **Start** button.
- 3 On the right side of the **Start** menu, click **Control Panel**.
- 4 Observe that the **Control Panel** opens.
- 5 In the **Control Panel** dialog box, under **Appearance and Personalization**, click **Adjust screen resolution**.
- 6 Change the display settings:
 - a Verify that the correct display is shown.
 - b Change the resolution to maximum permitted resolution for your display.
 - c Click **OK**.
 - d Observe that the screen resolution changes.
 - e Click **Keep changes** in the acknowledge dialog box that appears.
- 7 Click the [**X**] in the top right corner to close the **Control Panel**.

System test procedures

Refer to the *Harbour Acceptance Test (HAT)* and the *Sea Acceptance Test (SAT)* for operational tests.

Installation remarks

Use this space to document comments and remarks related to the installation. When the installation has been fully completed, and all functional tests have been performed to full satisfaction, representatives from all parties concerned must sign.

Vessel/Customer:	
Place and date:	
Comments:	

Signatures

Installation performed by	Company/Position	Date	Signature
Installation accepted by	Company/Position	Date	Signature

Drawing file

Topics

[About the drawings in the drawing file, page 168](#)

[General Purpose Transceiver \(GPT\) outline dimensions, page 169](#)

[GPT Power supply outline dimensions, page 172](#)

[Processor Unit outline dimensions, page 175](#)

[GPT Transducer connector wiring, page 179](#)

About the drawings in the drawing file

Drawings relevant for EK60 installation are provided.

Note

These drawings are for information and planning purposes only. They are not in scale. All dimensions are in mm unless otherwise is noted. The original installation drawings are available on PDF and/or AutoCad's DWG format.

The original drawings can be downloaded from our website.

- <http://www.simrad.com/ek60>
-

General Purpose Transceiver (GPT) outline dimensions

Drawing 201035 (Two pages).

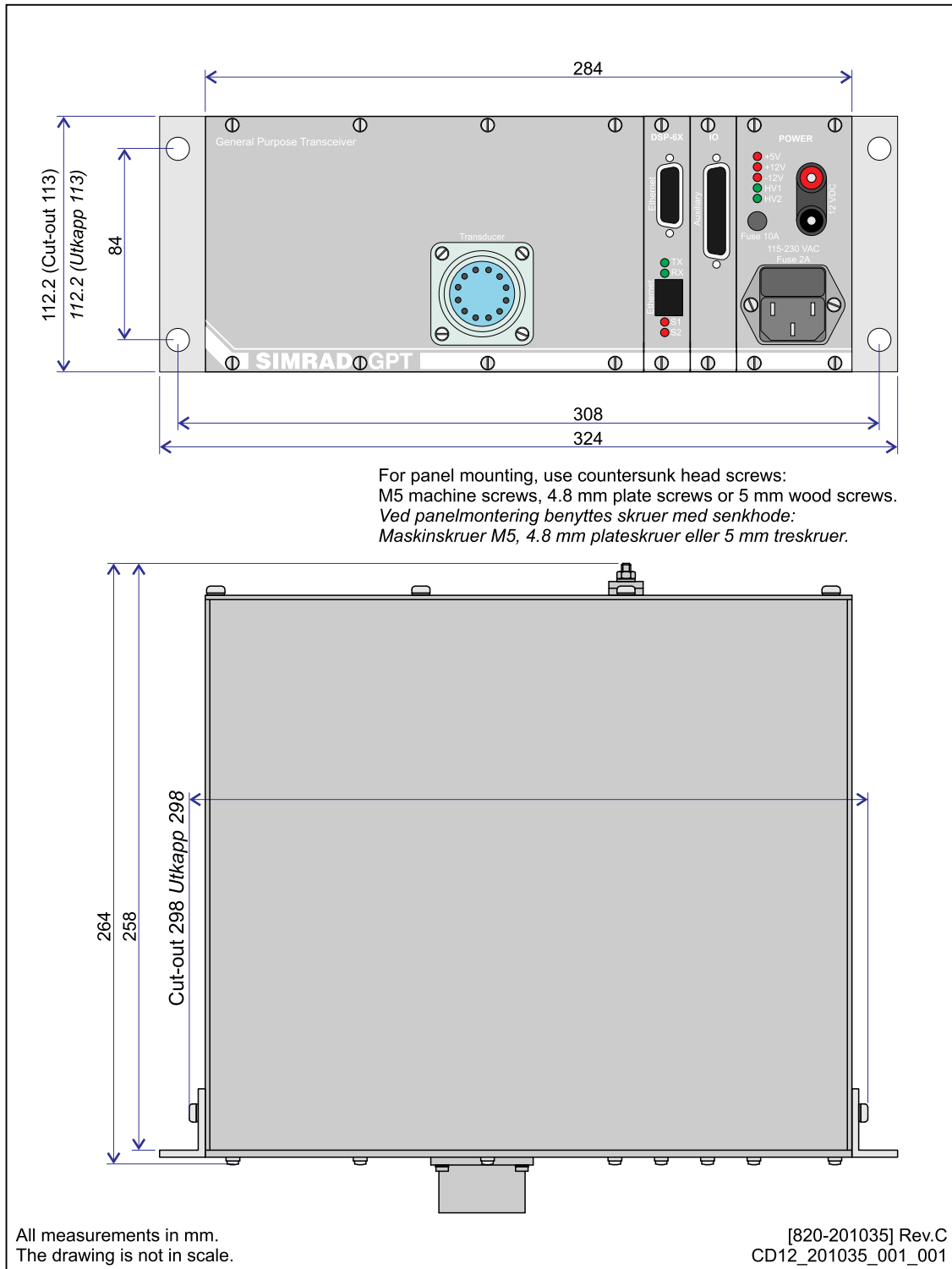

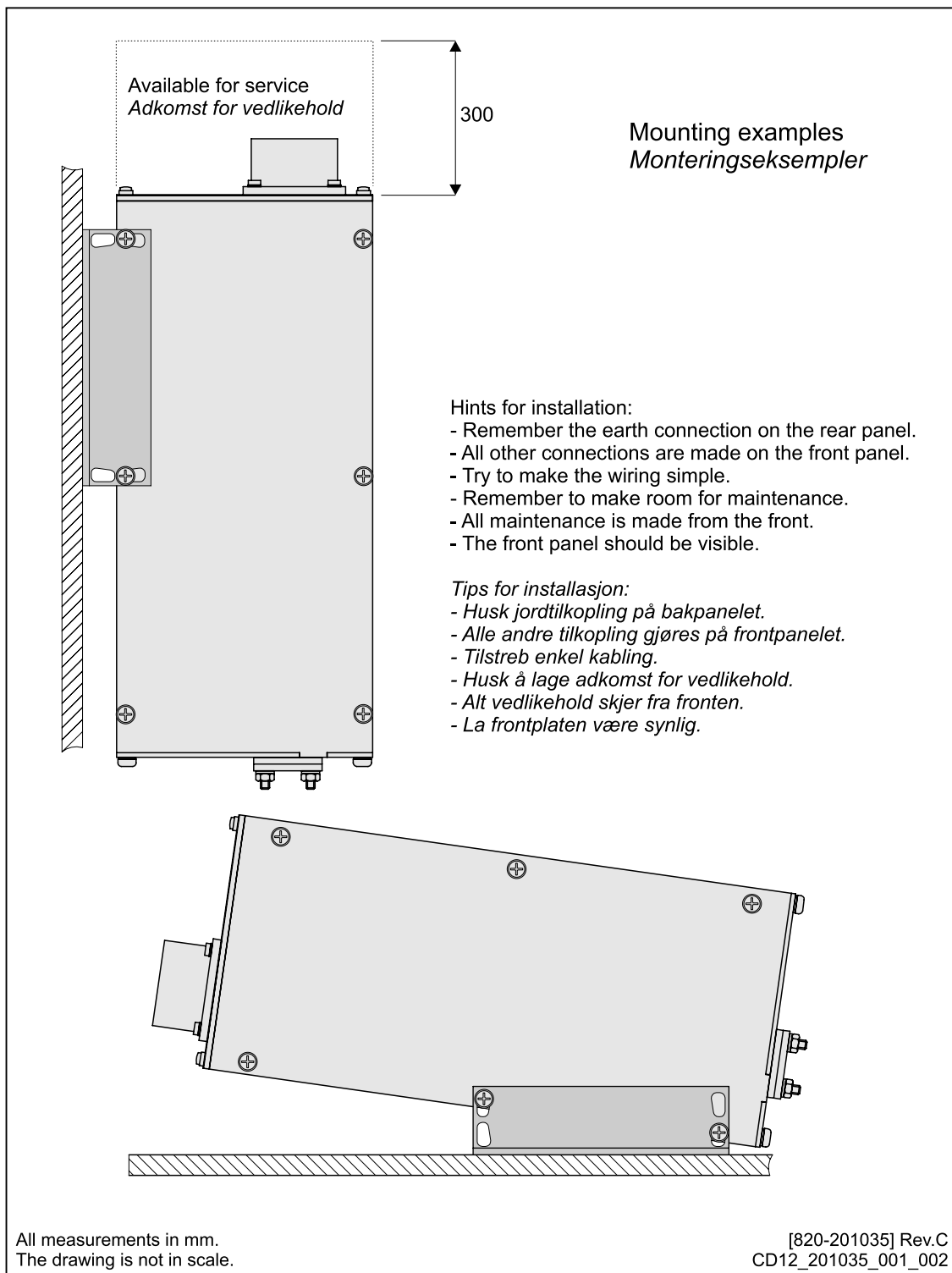

Related topics

[General Purpose Transceiver \(GPT\) description, page 19](#)

[Basic items provided with a standard delivery, page 25](#)

[Installing the General Purpose Transceiver \(GPT\), page 50](#)

[Weights and outline dimensions, page 185](#)

GPT Power supply outline dimensions

Drawing 305274 (Two pages).

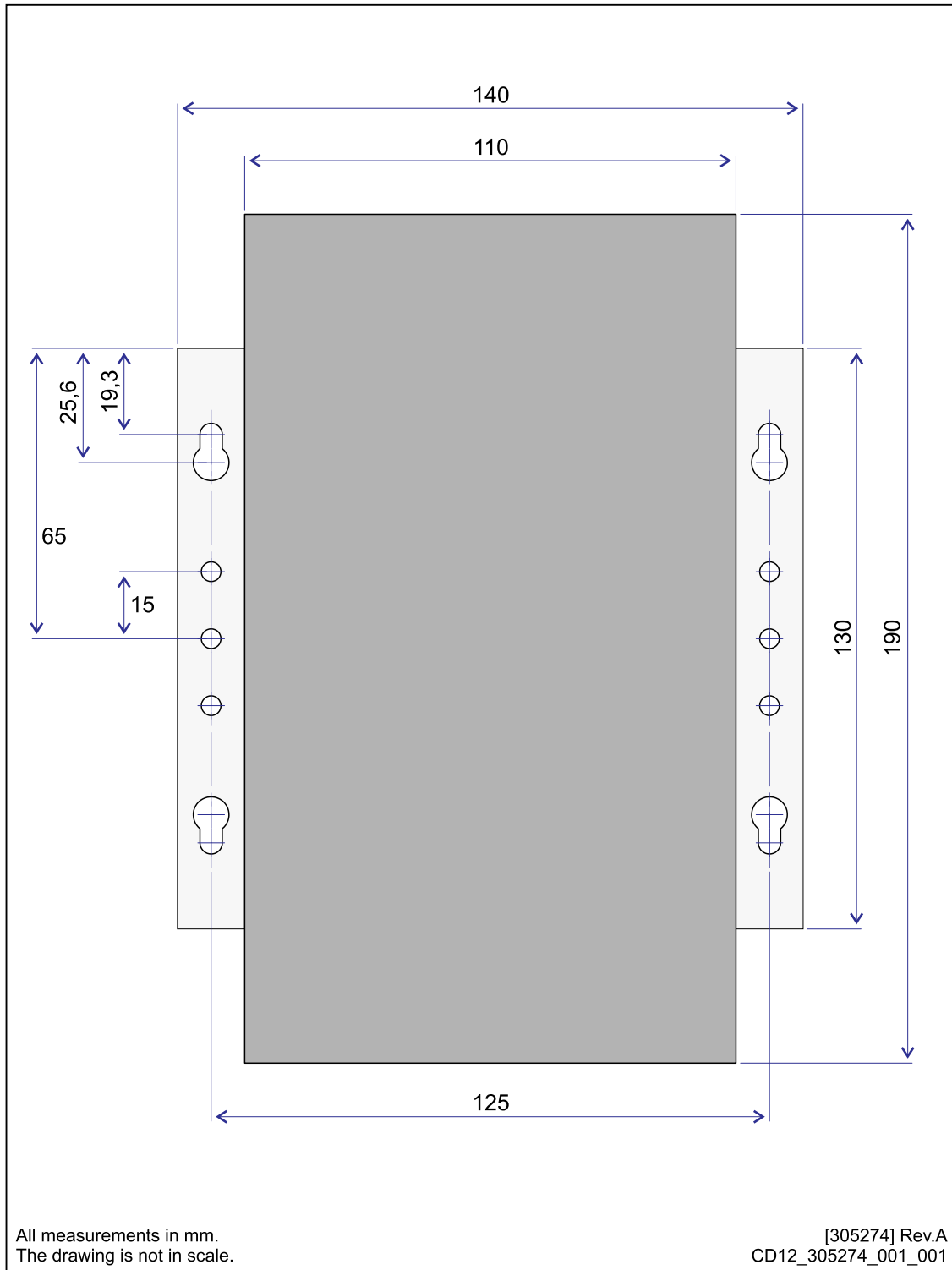

Page 2

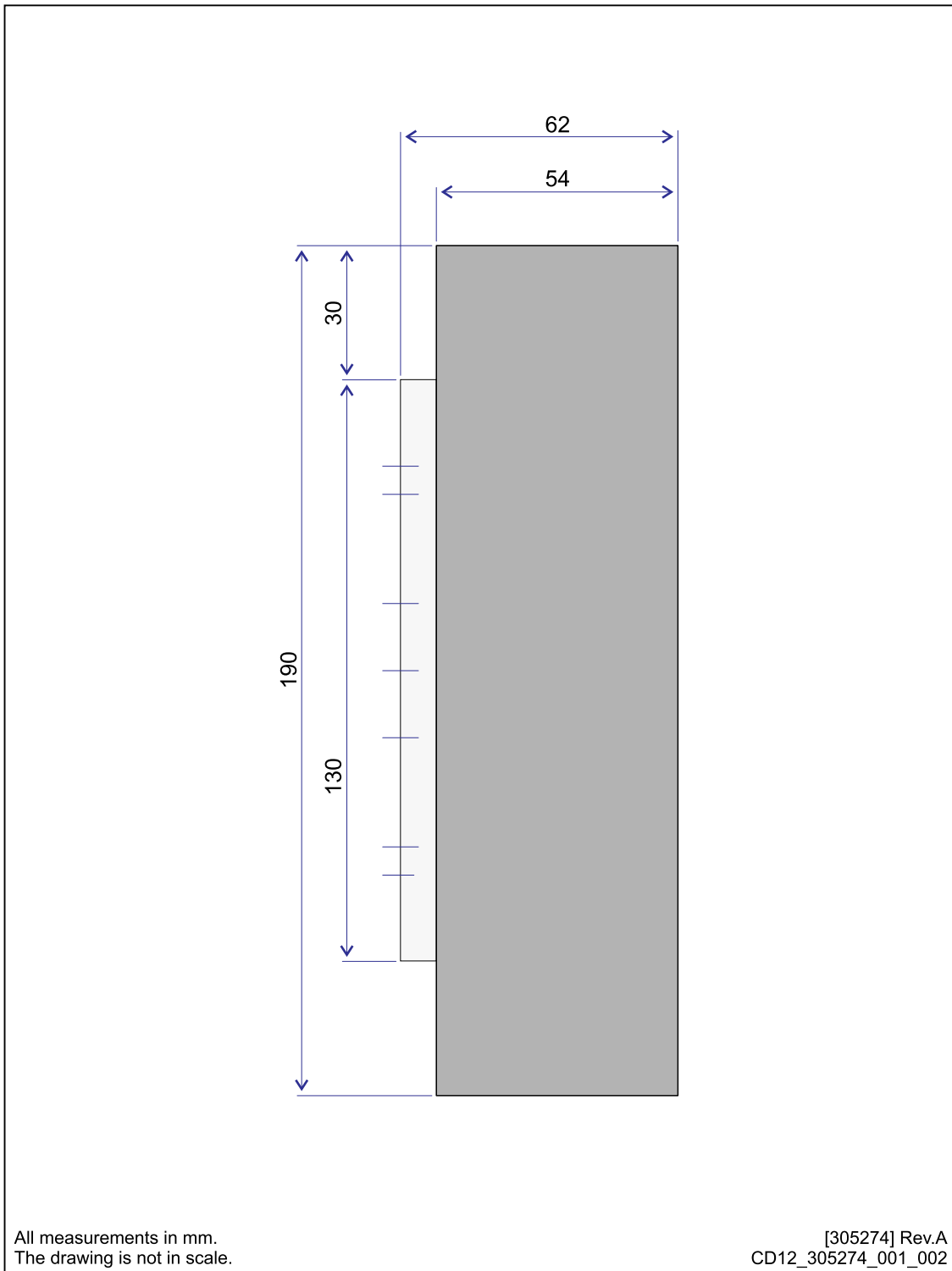

Related topics

[General Purpose Transceiver \(GPT\) description, page 19](#)

[Basic items provided with a standard delivery, page 25](#)

[Installing the General Purpose Transceiver \(GPT\), page 50](#)

[Weights and outline dimensions, page 185](#)

Processor Unit outline dimensions

Drawing 385609 (4 pages)

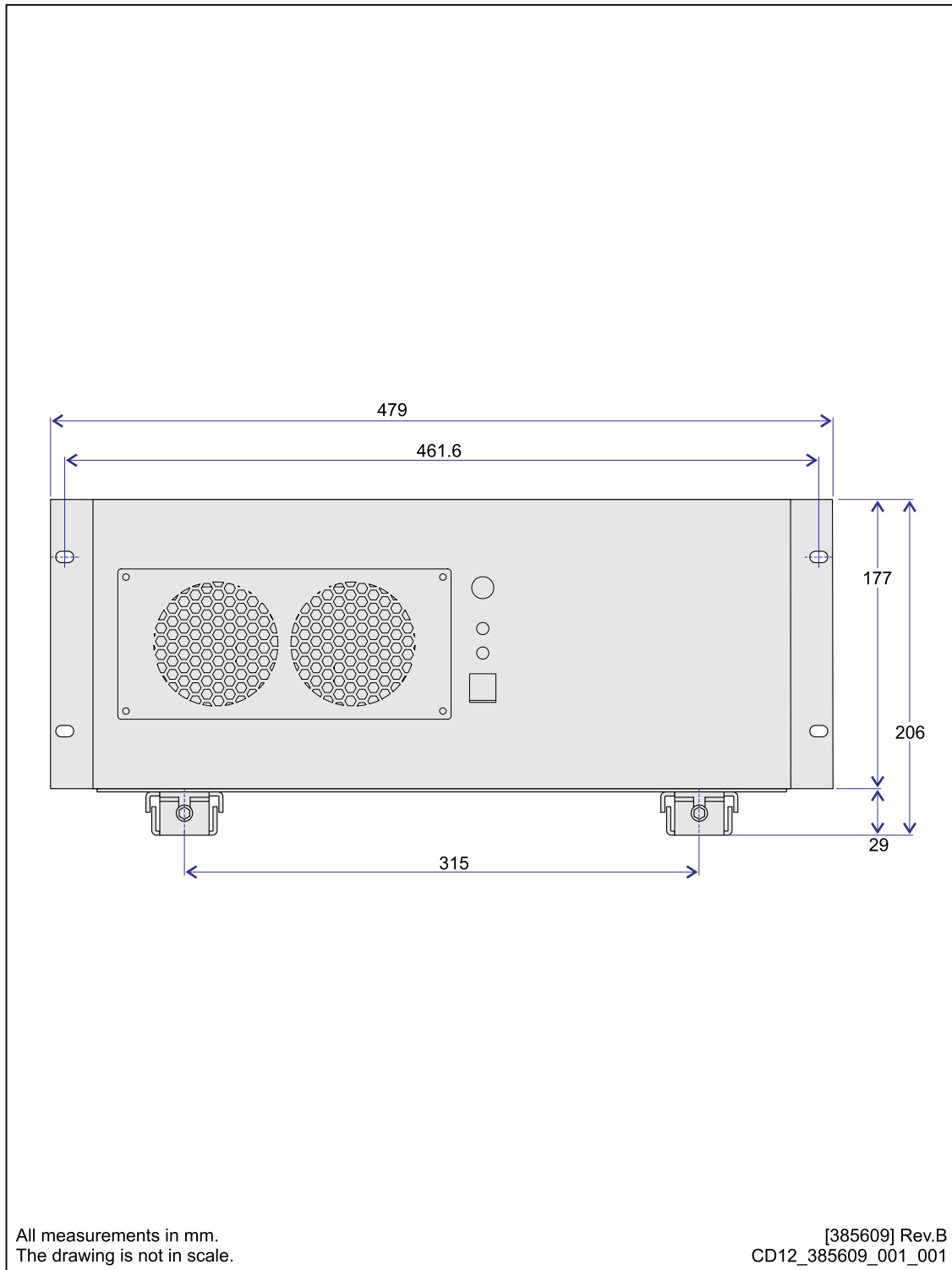

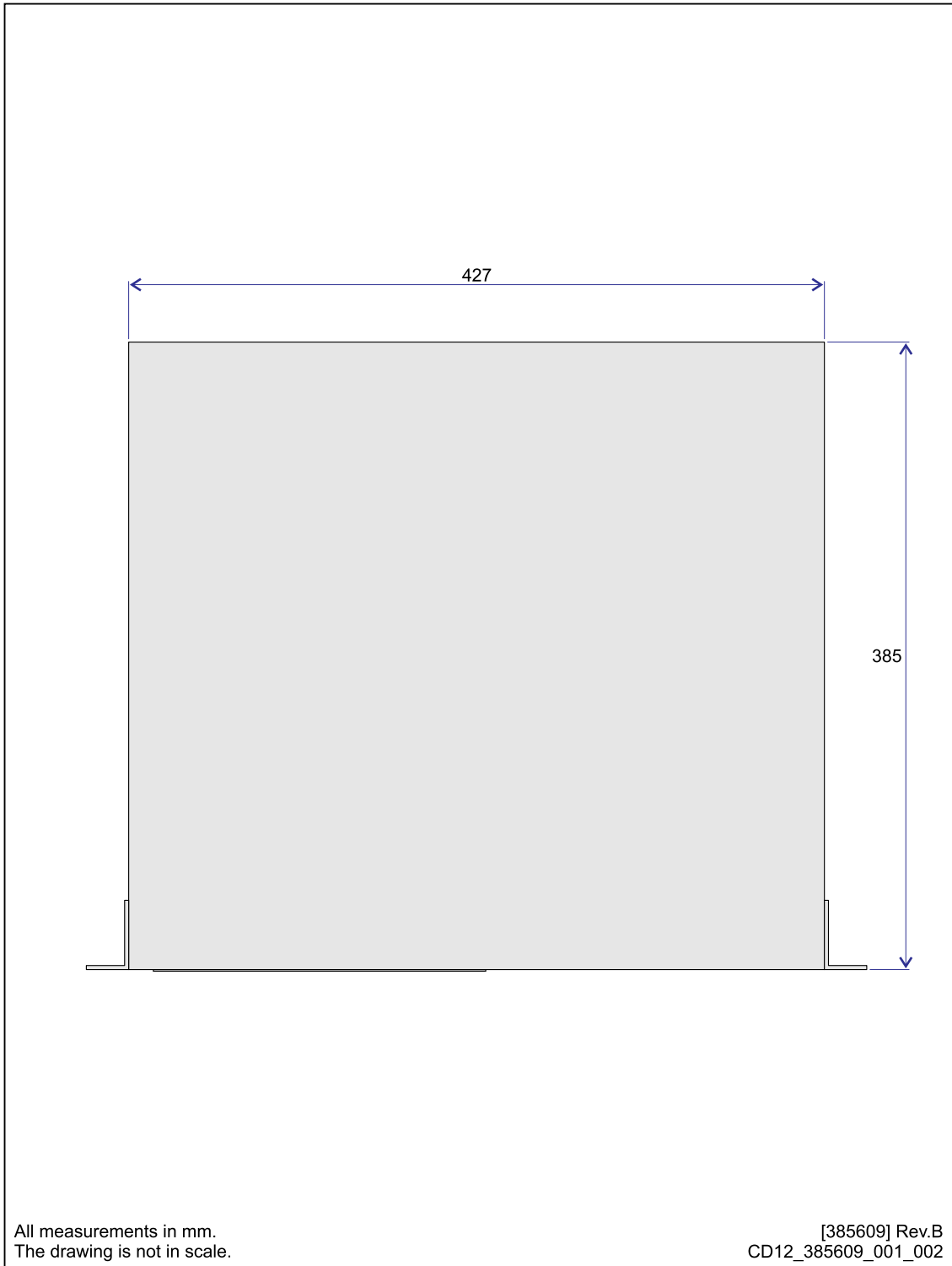

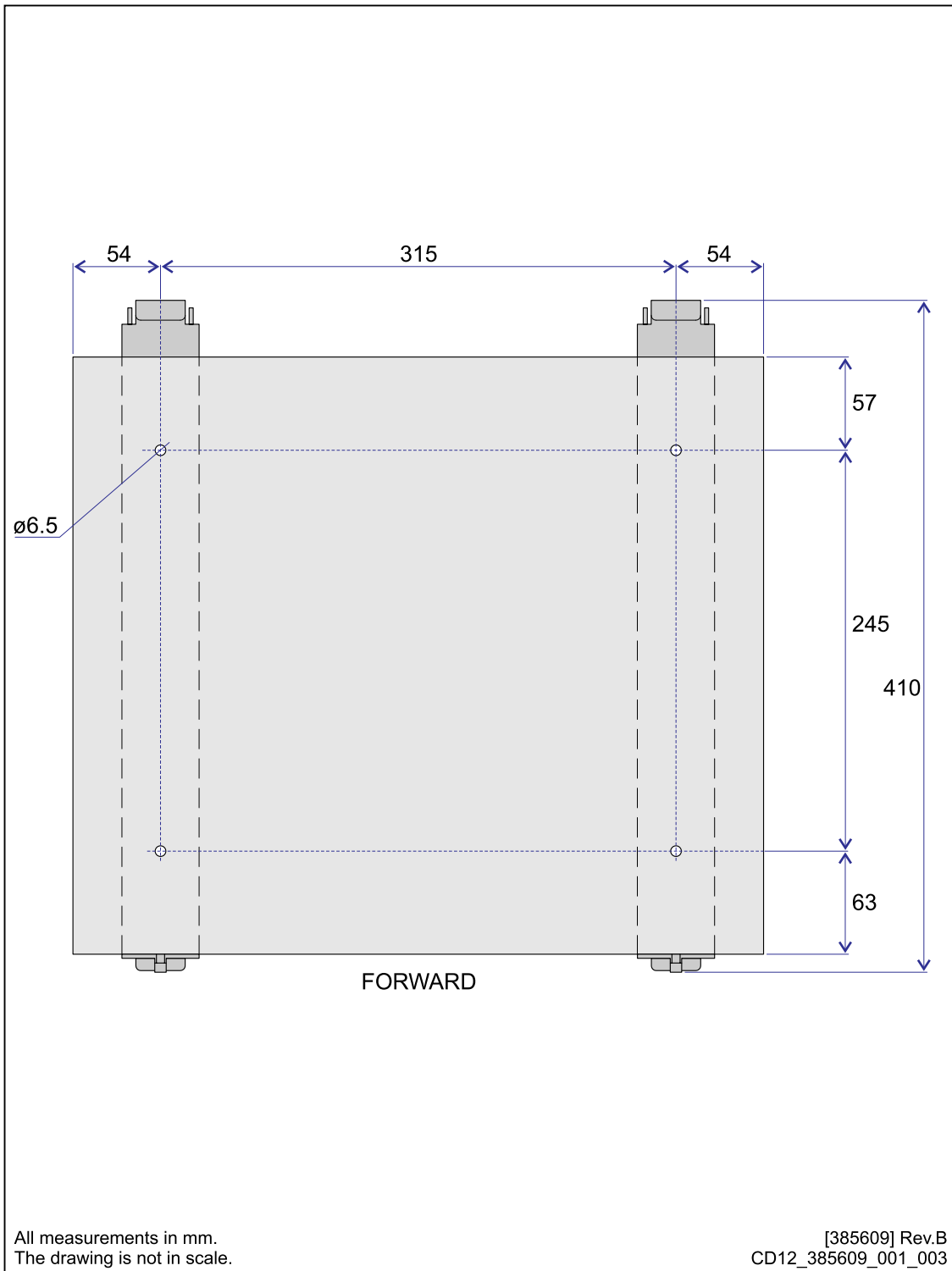

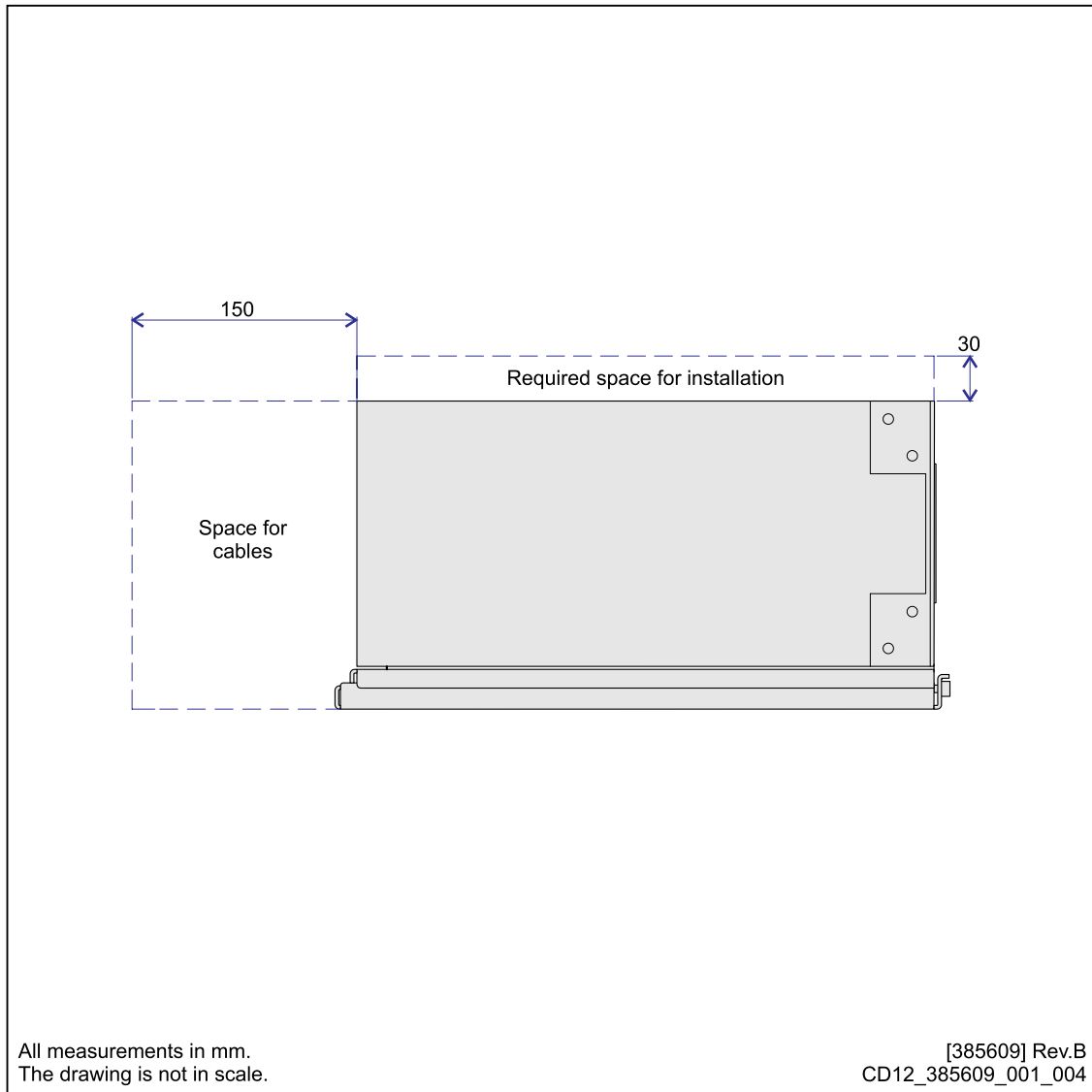

Related topics

[Processor Unit description, page 18](#)

[Additional required items, page 26](#)

[Installing the Enix Processor Unit, page 55](#)

[Weights and outline dimensions, page 185](#)

GPT Transducer connector wiring

Drawing 201575.

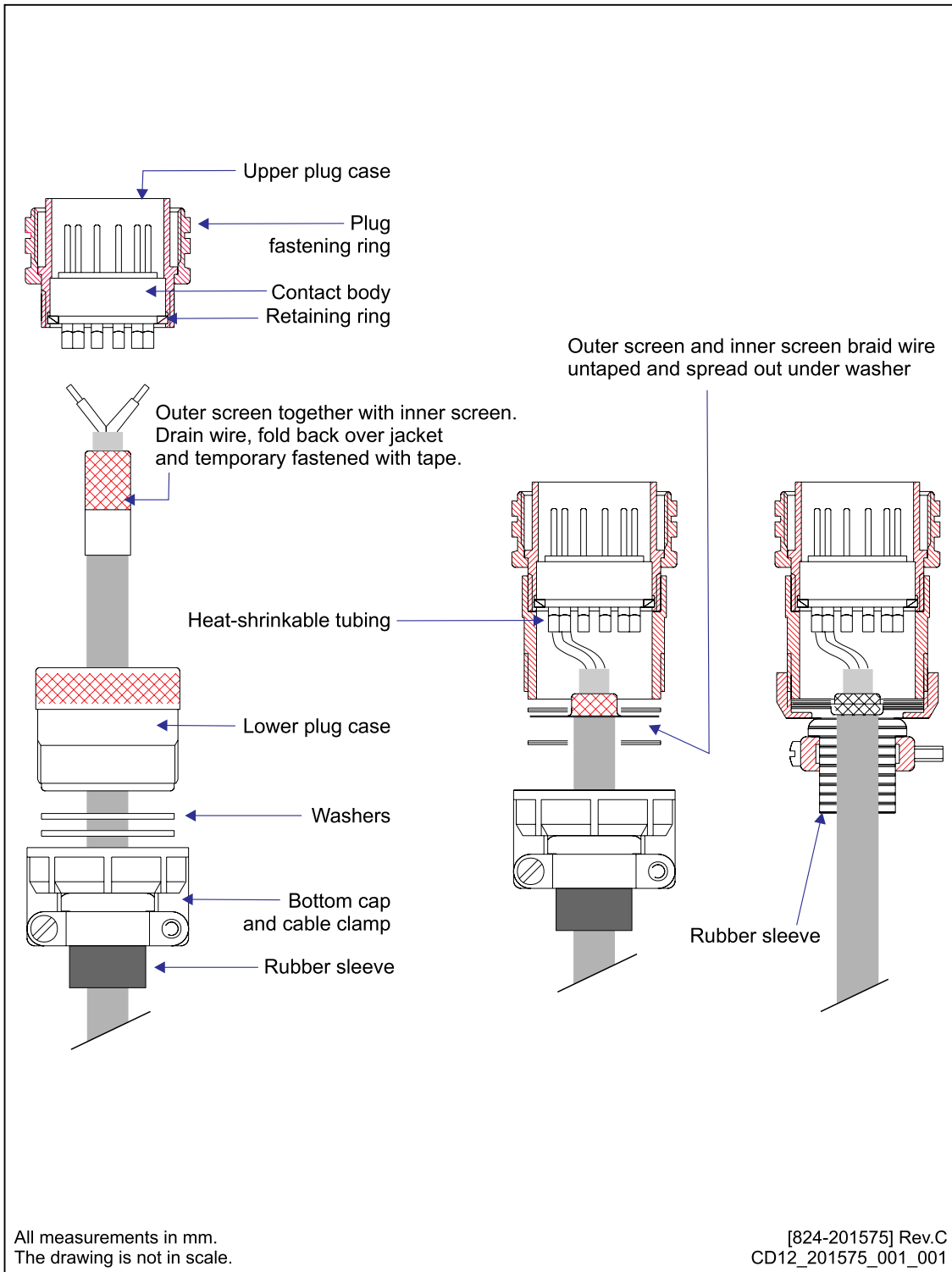

Technical specifications

Topics

[Introduction, page 181](#)

[Performance specifications, page 181](#)

[Interface specifications, page 182](#)

[Weights and outline dimensions, page 185](#)

[Power requirements, page 187](#)

[Environmental requirements, page 188](#)

[Minimum computer requirements, page 189](#)

[Minimum technical requirements for display, page 190](#)

Introduction

The technical specifications summarize the main functional and operational characteristics of the Simrad EK60 Scientific Echo Sounder, as well as information related to power requirements, physical properties and environmental conditions.

Note

In Kongsberg Maritime AS, we are continuously working to improve the quality and performance of our products. Technical specifications may therefore be changed without prior notice.

Performance specifications

The performance specifications summarize the main functional and operational characteristics of the Simrad EK60 system.

Operational specifications

- **Operating frequencies:** 18, 38, 70, 120, 200, 333 kHz
- **Ping rate:** Maximum 30 pings per second
This depends on chosen range, transmit power, pulse duration and other factors.
- **Data collection range:** 0 to 15,000 meters depending on pulse duration
- **Operational modes:** Active, Passive, Test
- **Transmit power:** Output power adjustable in steps
- **Receiver noise figure:** 4 dB
- **Receive filtering:** Matched digital filters
- **Split beam:** Complex digital demodulation

Functional specifications

- **Scope presentation:** Displays the echo strength of the most recent ping.
- **Bottom detector:** Software tracking algorithm, adjustable minimum and maximum depth
- **Operating system:** Microsoft® Windows® XP or Microsoft® Windows® 7
- **Transceiver control:**
 - Maximum seven transceivers controlled simultaneously.
 - Operation, Transmit power, Pulse duration, Ping rate, Data collection range
- **Calibration:** Built-in application
- **Sensor inputs:** GPS, Heave, Roll, Pitch, Trawl, Purse seine, Others

- **Manual input:** CTDdata, Speed
- **Views:** Echogram, Target position, Target strength distribution, Colour scale, Numerical, Bottom depth
- **Echogram view:**
 - Volume backscattering strength
 - Target strength
 - Single target
 - Virtually unlimited number of simultaneous echogram views with individual settings
- **Vertical range:** Adjustable 1 to 15.000 m
- **Horizontal time span:** Ping, Time or Distance based
- **Layers:** Virtually unlimited number of configurable layers
- **Calculation interval:** Ping, Time or Distance based
- **Single target detection settings:** Adjustable
- **Bottom detection settings:** Adjustable
- **Access control:** Identified users with password protection
- **User configuration:** Save and load personal settings
- **Data server:** Ethernet datagram based system for remote subscription of data
- **Raw data storage:** Storage of complex sample data
- **Processed output:** To serial line or Ethernet
- **Printer output:** On-line printing
- **Replay:** Replay of previously recorded data
- **Synchronisation:** Internal or external (from serial port or transceiver)

Interface specifications

Interface specifications

The EK60 will interface with peripheral systems and sensors using standard and/or proprietary datagram formats.

Outputs

- Bottom depth
- Depth data

Inputs

- Navigation (Position, speed, distance, heading)
- Motion
- Annotations
- Transmit synchronization

Supported datagram formats for position information

The EK60 supports the following datagram formats for position information.

- **Auto**

The EK60 will read all relevant datagrams. If the specified information is provided to the system on more than one datagram format, a built-in priority list will be used.
- **GGA**

This NMEA datagram format contains time, position and fix related data from a global positioning system (GPS).
- **GLL**

This NMEA datagram format is used to transfer latitude and longitude of vessel position, time of position fix, and status from a global positioning system (GPS).
- **RMC**

This NMEA datagram format contains time, date, position, course and speed data provided by a global navigation satellite system (GNSS) receiver.

Supported datagram formats for speed information

The EK60 supports the following datagram formats for speed information.

- **Auto**

The EK60 will read all relevant datagrams. If the specified information is provided to the system on more than one datagram format, a built-in priority list will be used.
- **VBW** Dual ground and water speed
- **VTG**

This NMEA datagram format contains the actual course and speed relative to the ground.
- **RMC**

This NMEA datagram format contains time, date, position, course and speed data provided by a global navigation satellite system (GNSS) receiver.

Supported datagram formats for distance information

The EK60 supports the following datagram format for vessel distance information.

- **VLW**

This NMEA datagram format contains the distance travelled relative to the water and over the ground.

Supported datagram formats for heading information

The EK60 supports the following datagram formats for vessel heading information.

- **Auto**

The EK60 will read all relevant datagrams. If the specified information is provided to the system on more than one datagram format, a built-in priority list will be used.

- **HDG**

This NMEA datagram format contains the heading from a magnetic sensor, which if corrected for deviation will produce magnetic heading, which if offset by variation will provide true heading.

- **HDM**

This NMEA datagram format contains vessel heading in degrees magnetic.

- **HDT**

This NMEA datagram format is used to transfer heading information from a gyro.

- **VHW**

This NMEA datagram format contains the compass heading to which the vessel points and the speed of the vessel relative to the water.

Supported datagram formats for motion sensor information

The EK60 supports the following datagram formats from a motion sensor.

- Sounder/TSS1 (Proprietary Kongsberg Maritime motion protocol)
- EM1000 (Proprietary Kongsberg Maritime motion protocol)
- EM3000 (Proprietary Kongsberg Maritime motion protocol)

Supported datagram format for annotations

The EK60 supports the following datagram format for annotations.

- **ATS**

This is a proprietary format developed by Kongsberg Maritime for use with annotations

Supported datagram formats for depth output

The EK60 supports the following datagram formats for depth output.

- **DBS**

This NMEA datagram format provides the current depth from the surface. The datagram is no longer recommended for use in new designs.

- **DBT**

This NMEA datagram format provides the water depth referenced to the transducer.

- **DPT**

This NMEA datagram format contains water depth relative to the transducer and offset of the measuring transducer.

- **Simrad**

This is the proprietary "EK500 Depth" datagram format created by Kongsberg Maritime to contain depth data.

- **PSIMDHB**

This proprietary datagram format created by Simrad contains the bottom hardness and biomass as calculated by an echo sounder.

- **Atlas**

This is a third party proprietary datagram format for depth information. It was created by Atlas Elektronik (<https://www.atlas-elektronik.com>) for use with their echo sounders.

Weights and outline dimensions

The weights and outline dimension characteristics summarize the physical properties of the Simrad EK60 Scientific Echo Sounder.

Note

For more detailed information about the physical dimensions, see the Drawing file.

Processor Unit

- **Make and model:** Simrad Enix
- **Outline dimensions:**
 - **Depth:** 385 mm
 - **Width:** 479,6 mm (fits in a 19" rack)
 - **Height:** 177 mm
- **Weight:** approximately 16 kg

The technical specifications are those valid for the computer that may be ordered from Kongsberg Maritime as a part of the EK60 delivery. For specifications related to a locally purchased computer, refer to the documentation provided with the unit.

Transceiver Unit

- **Type:** General Purpose Transceiver (GPT)
- **Depth:** 264 mm
- **Width:** 284 mm (excluding mounting brackets)
- **Height:** 112.2 mm
- **Weight:** Approximately 6 kg (or less, depends on hardware configuration)

Ethernet switch

- **Manufacturer:** Black Box
- **Manufacturer's website:** <http://www.blackbox.co.uk>
- **Type:** LBS209AE-R2
- **Physical dimensions:**
 - **Height:** 44 mm
 - **Width:** 22.8 mm
 - **Depth:** 123 mm
- **Weight:** 1.2 kg

These specifications were taken from the manufacturer's website in June 2013. The specifications may be altered without prior notice.

The technical specifications are those valid for the Ethernet switch that may be ordered from Kongsberg Maritime as a part of the EK60 delivery. For specifications related to a locally purchased Ethernet switch, refer to the documentation provided with the unit.

Display

The display is not a part of the EK60 scope of supply, and it is not manufactured by Kongsberg Maritime. Refer to the documentation provided by the manufacturer.

Related topics

[Processor Unit outline dimensions, page 175](#)

[General Purpose Transceiver \(GPT\) outline dimensions, page 169](#)

[GPT Power supply outline dimensions, page 172](#)

Power requirements

The power specifications summarize the supply power requirements for the Simrad EK60 Scientific Echo Sounder.

Processor Unit

- **Make and model:** Simrad Enix
- **Voltage requirement:** 115/230 Vac / 47 to 63 Hz / single phase
- **Maximum voltage deviation:** 15%
- **Maximum transient:** 20% of nominal voltage, recovery time 3 s
- **Power consumption:** Approximately 500 W @ 230 Vac

The technical specifications are those valid for the computer that may be ordered from Kongsberg Maritime as a part of the EK60 delivery. For specifications related to a locally purchased computer, refer to the documentation provided with the unit.

Transceiver Unit

- **Type:** General Purpose Transceiver (GPT)
- **Voltage requirements:**
 - 230 Vac / 47–63 Hz / single phase
 - 12–32 Vdc, 5A
- **Maximum voltage deviation:** 15%
- **Maximum transient:** 20% of nominal voltage, recovery time 3 s
- **Power consumption:** Approximately 100 VA

Ethernet switch

- **Manufacturer:** Black Box
- **Manufacturer's website:** <http://www.blackbox.co.uk>
- **Type:** LBS209AE-R2
- **Voltage requirement:** 100 to 240 Vac

These specifications were taken from the manufacturer's website in June 2013. The specifications may be altered without prior notice.

The technical specifications are those valid for the Ethernet switch that may be ordered from Kongsberg Maritime as a part of the EK60 delivery. For specifications related to a locally purchased Ethernet switch, refer to the documentation provided with the unit.

Display

The display is not a part of the EK60 scope of supply, and it is not manufactured by Kongsberg Maritime. Refer to the documentation provided by the manufacturer.

Environmental requirements

The environmental specifications summarize the temperature and humidity requirements for the Simrad EK60 system.

Processor Unit

- **Make and model:** Simrad Enix
- **Operational temperature:** –15 to +55°C
- **Storage temperature:** –20 to +70°C
- **Relative humidity:** 10 to 95% relative non-condensing
- **Certificates:**
 - IEC 60945
 - IACS E10

The technical specifications are those valid for the computer that may be ordered from Kongsberg Maritime as a part of the EK60 delivery. For specifications related to a locally purchased computer, refer to the documentation provided with the unit.

Transceiver Unit

- **Type:** General Purpose Transceiver (GPT)
- **Operational temperature:** 0 to +50°C
- **Storage temperature:** –40 to +70°C
- **Relative humidity:** 5 to 95% relative non-condensing

Ethernet switch

- **Manufacturer:** Black Box
- **Manufacturer's website:** <http://www.blackbox.co.uk>
- **Type:** LBS209AE-R2
- **Operational temperature:** 0 to +50°C
- **Relative humidity:** 10 to 90% relative non-condensing

These specifications were taken from the manufacturer's website in June 2013. The specifications may be altered without prior notice.

The technical specifications are those valid for the Ethernet switch that may be ordered from Kongsberg Maritime as a part of the EK60 delivery. For specifications related to a locally purchased Ethernet switch, refer to the documentation provided with the unit.

Display

The display is not a part of the EK60 scope of supply, and it is not manufactured by Kongsberg Maritime. Refer to the documentation provided by the manufacturer.

Minimum computer requirements

Although a computer can be ordered from Kongsberg Maritime as a part of the EK60 delivery, it is also possible to purchase one locally.

If you purchase a computer locally, make sure that the chosen model meets the functional and technical requirements.

It is important to make sure that the chosen computer model is relatively new with sufficient processing power, a high performance graphic adapter, and a high speed network adapter.

The computer must be able to facilitate the various interface requirements made by the EK60, and you may need to add extra Ethernet and serial adapters.

Note

The computer design and construction must allow for maritime use, easy access to connectors, parts and cables, and a safe installation.

A laptop computer may be used as long as it meets the functional and technical requirements.

The minimum technical requirements are:

- **Processor:** 2 GHz, Dual core
- **Memory capacity:** Minimum 2 Gb
- **Hard disk capacity:** Minimum 30 Gb free space

Note

If you wish to record raw data, you must either install a large hard disk, use peripheral storage devices, or connect the Processor Unit to the ship's network.

- **Graphic adapter:**
 - Minimum resolution is 1280 x 1024 pixels.
 - The graphic adapter must support DirectX9.0c, and must be compatible with Direct3d and OpenGL.

A large number of commercial graphic adapters are available, and we have not tested all of them. Even adapters that meet the minimum specifications may fail with the EK60 software. We welcome any feedback with comments or experiences with graphic adapters.

- **Ethernet interfaces:** The Processor Unit must offer minimum one 1 Gb/s Ethernet adapter. Two are required if the Processor Unit shall also be connected to a local area network (LAN).

- **Serial interfaces:** One or more serial line interfaces are also required. The number of serial lines depend on the interface requirements.

Tip

If you have connected a USB-to-serial adapter to the Processor Unit, do not remove it while the EK60 is running. Also, do not move the adapter to a different USB socket on the Processor Unit.

- **Operating system:** The EK60 software has been designed for 32-bit Windows® 7. For all new EK60 installations, we recommend that Windows® 7 is used.

Note

On Windows® XP® computers, Service Pack 3 is required.

Related topics

[Processor Unit description, page 18](#)

[Additional required items, page 26](#)

Minimum technical requirements for display

Unless specifically ordered, the EK60 is not provided with a display. This item must then be purchased locally.

Note

It is important that the chosen display meets the technical system requirements. The display design and construction must allow for maritime use, easy access to cables, and a safe installation.

The minimum technical requirements are:

- **Resolution:** Minimum 1280 x 1024 pixels.
- **Video interface:** These must match the video output formats provided by the Processor Unit.

The Processor Unit offers video output on several formats. Investigate your options before purchasing a display.

- **Physical size:** This depends on personal and operational preferences.

The EK60 software supports 9:16 displays.

Tip

If you use the EK60 with many transceivers, you may find it useful with a large high resolution display.

Related topics

[Display description, page 17](#)

[Additional required items, page 26](#)

Equipment handling

Observe these basic rules for transportation, storage and handling of units. In this context, a *unit* may be any large or small part of the system. It can be supplied as part of the initial delivery, or as a spare part. The phrase *box* is used to describe all kinds of cases, wooden or cardboard boxes etc used to hold the *unit*.

Topics

[Transporting Kongsberg Maritime equipment, page 193](#)

[Lifting units and transportation boxes, page 194](#)

[Inspection of units and transportation boxes after arrival, page 195](#)

[Specifications for storage prior to installation or use, page 196](#)

[Unpacking instructions, page 197](#)

[Specifications for storage after unpacking, page 202](#)

[Packing instructions for storage or shipping, page 203](#)

[Storage after use, page 204](#)

[Handling instructions for printed circuit boards and electronic modules, page 206](#)

[Disposal of old products, page 211](#)

Transporting Kongsberg Maritime equipment

Unless otherwise stated in the accompanying documentation, electronic, electromechanical and mechanical units supplied by Kongsberg Maritime can be only transported using methods approved for delicate and fragile equipment.

Prerequisites

Transportation methods approved for delicate equipment includes transportation by road, rail, air or sea.

Context

The units are to be transported in accordance with general or specific instructions for the appropriate unit(s), using pallets, transport cases, wooden boxes, or carton boxes as appropriate.

Observe the packing instructions.

Note

Special local restrictions concerning air transportation may be applied to units containing certain types of batteries. These units must be checked properly, and the regulations must be investigated by the packer/shipper before the unit is dispatched.

Procedure

- 1 Ensure that all local transportation is done according to the same specifications as for the initial delivery.
- 2 Make sure that the box containing the unit is kept dry at all times, and sheltered from the weather.

It must not be subjected to shocks, excessive vibration or other rough handling. The box will normally be marked with text or symbols indicating which way it is to be placed. Follow the instructions provided, and make sure that the box is always placed with its “top” facing upwards.

- 3 Make sure that the box is not used for any purpose for which it was not intended (step, table, etc.).

In the absence of other information, no other boxes must be stacked on top of it.

- 4 Handle all boxes and units with care.

Note

Due to the nature of Kongsberg Maritime’s products, and the extensive use of delicate electronic parts, all units and boxes must be regarded and handled as fragile equipment.

Related topics

[Packing instructions for storage or shipping, page 203](#)

[Circuit board unpacking and handling, page 207](#)

[Lifting units and transportation boxes, page 194](#)

Lifting units and transportation boxes

Some of the boxes used to hold equipment units may be heavy. Use caution when lifting.

Prerequisites

Units and boxes may be heavy. Make sure that you have the necessary equipment required for lifting heavy items. Persons using the lifting equipment must be skilled and have the relevant certificate(s).

Context

A heavy box will normally be marked with its weight. The weights of other boxes in the shipment will normally be entered on the packing list(s).

Heavy units may be equipped with dedicated lifting lugs for transportation by crane within the workshop or installation area.

Note

Observe the local rules and regulations related to the use of lifting equipment.

Procedure

- 1 Check the weight of the box or unit before you attempt to lift it.
- 2 Make sure that you have the relevant lifting apparatus required, and that this equipment is approved and certified for the load.
- 3 If you need to use a crane:
 - a Check the applicable weight certificate for the crane.
 - b Check the security of the lifting lugs.
 - c If the unit to be lifted is provided with dedicated lifting lugs, make sure that all available lugs are used.
 - d Make sure that the unit remains under full control during the lifting operation.
This is important to avoid damage to the unit, equipment or personnel.
- 4 If you need to use a forklift truck:
 - a Check the applicable weight certificate for the truck.
 - b Check the limitations for lifting height and angles.
 - c Pay special attention to the position of the unit's centre of gravity.

- d Make sure that the unit is properly secured to the truck during the lifting and transportation operations.
- 5 Handle all units and boxes with care.

Note

Due to the nature of Kongsberg Maritime's products, and the extensive use of delicate electronic parts, all units and boxes must be regarded and handled as fragile equipment.

Related topics

[Transporting Kongsberg Maritime equipment, page 193](#)

[Packing instructions for storage or shipping, page 203](#)

Inspection of units and transportation boxes after arrival

A visual inspection must be done immediately after the box(es) have arrived at their destination.

Prerequisites

If you suspect that the equipment has been damaged during the transport, request that a representative of the carrier is present during the inspection.

Procedure

- 1 Check all boxes (wooden or cardboard boxes, plastic bags and/or pallets) for physical damage.
Look for signs of dropping, immersion in water or other mishandling.
- 2 If external damage is detected, open the box to check its contents.
Request that a representative of the carrier to be present while the box is opened, so any transportation damage can be identified and documented.
- 3 If a unit has been damaged, prepare an inspection report stating the condition of the unit and actions taken.
Describe the damage, and collect photographic evidence if possible. Return the inspection report to Kongsberg Maritime as soon as possible.
- 4 If units are not damaged, check the humidity absorbing material.
If required, dry or replace the bags, then re-pack the unit(s) according to the packing instructions.

Specifications for storage prior to installation or use

When a system, a unit or a spare part has been delivered to the customer, it may be subject to long time storage prior to installation and use.

General specifications

During this storage period, certain specifications must be met. The equipment must be preserved and stored in such a way that it does not constitute any danger to health, environment or personal injury.

- 1 The equipment must be stored in its original transportation box.
- 2 Ensure that the units are clearly separated in the shelves and that each unit is easily identifiable.
- 3 The box must not be used for any purpose for which it was not intended (work platform, steps, table etc.).
- 4 Boxes must not be placed on top of each other, unless specific markings permit this.
- 5 Boxes must not be placed directly on a dirt floor.
- 6 Do not open a box for inspection unless special circumstances permit so.
“Special circumstances” may be suspected damage to the box and its content, or inspections by civil authorities.
 - a If a unit is damaged, prepare an inspection report stating the condition of the unit and the actions taken. Describe the damage and collect photographic evidence if possible. Re-preserve the equipment.
 - b If the unit is not damaged, check the humidity absorbing material. If required, dry or replace the bags, then re-pack the unit according to the packing instructions.
- 7 If a box has been opened, make sure that it is closed and sealed after the inspection. Use the original packing material as far as possible.
- 8 The storage room/area must be dry with a non-condensing atmosphere. It must be free from corrosive agents.
- 9 The storage room/area’s mean temperature must not be lower than -10° C, and not warmer than +50° C. If other limitations apply, the crates will be marked accordingly.
- 10 Boxes must not be exposed to moisture from fluid leakages.
- 11 Boxes must not be exposed to direct sunlight or excessive warmth from heaters.
- 12 Boxes must not be subjected to excessive shock and vibration.
- 13 If the unit contained in a box holds normal batteries, these may have been disconnected/isolated before the unit was packed. These must only be reconnected before the installation starts. Units containing batteries are marked.

Caution

Units containing lithium or alkaline batteries must be handled separately and with care. Such units are marked accordingly. Do not attempt to recharge such batteries, open them, or dispose of them by incineration.

Refer to the applicable product data sheets or battery handling procedures for further details.

Temperature protection

Any units that requires protection against extreme temperatures are identified as such in the applicable documentation. The box used to transport and store such units are clearly marked, for example:

Must not be transported or stored in temperatures below -5 °Celsius.

Other temperature limits may be used if applicable.

If a unit needs temperature protection, the box to be used for storage and transportation must be lined on all walls, base and lid, using minimum 5 cm thick polyurethane or polystyrene foam.

Most system units can normally be stored in temperatures between -30° C and +70° C. Refer to the relevant technical specifications for details.

Note

Unless otherwise specified, transducers and hydrophones must not be stored in temperatures below -10° C and above +50° C.

Unpacking instructions

Prior to installation or use, electronic, electromechanical and mechanical units must be unpacked from their transport boxes. It is important that this unpacking is done according to the relevant instructions, and without inflicting damage to the equipment.

Topics

[Unpacking standard parts and units, page 198](#)

[Unpacking mechanical units, page 199](#)

[Unpacking electronic and electromechanical units, page 200](#)

[Unpacking transducers, page 201](#)

Unpacking standard parts and units

Prior to installation or use, parts and units must be inspected, and then unpacked from their transport boxes. It is important that this unpacking is done without inflicting damage to the equipment.

Context

This procedure provides the basic tasks of unpacking units (main unit, spare parts etc) from boxes shipped from Kongsberg Maritime.

Note

If the unit in question is not unpacked for immediate use, you may consider storing it unopened in its original box. However, it may be useful to open the box to check its contents for damage and retrieve any accompanying documentation.

Do not use a knife to open cardboard boxes - the contents may be located close to the surface, and can then be damaged by the blade.

Procedure

- 1 Check the carton before opening it to ensure it shows no signs of dropping, immersion in water or other mishandling.
 - 1 If external damage is detected, open the box to check its contents.
 - 2 Request that a representative of the carrier to be present while the box is opened, so any transportation damage can be identified and documented.
 - 3 If a unit has been damaged, prepare an inspection report stating the condition of the unit and actions taken.

Describe the damage, and collect photographic evidence if possible. Return the inspection report to Kongsberg Maritime as soon as possible.
- 2 Place the box on a stable work bench or on the floor with the top of the box facing upwards.
- 3 In the absence of other instructions, always open the top of the carton first.

The contents of the box will normally have been lowered into the carton from above, so this will usually be the easiest route to follow. Be careful when you open the box, and make sure that the contents are not damaged. Do not use a knife to open cardboard boxes.
- 4 If the box has been closed using staples, remove the staples from the carton as you open it.

This will reduce the possibilities of scratch injury to yourself and damage to the contents.
- 5 If a wooden box has been closed using screws, always remove them using a screwdriver.

Do not attempt to force the lid open with a crowbar or similar tool.

- 6 Once the carton is open, carefully remove all loose packing and insulation material.
- 7 Check for user manuals and other documents that may have been added to the carton during packing.
- 8 Check also for special tools, door keys etc.

Related topics

[Unpacking mechanical units, page 199](#)

[Unpacking electronic and electromechanical units, page 200](#)

[Unpacking transducers, page 201](#)

Unpacking mechanical units

Prior to installation or use, mechanical units must be unpacked from their transport boxes. It is important that this unpacking is done without inflicting damage to the equipment.

Prerequisites

Observe the procedure for unpacking of standard parts and units.

Context

Mechanical and electromechanical units may be heavy.

A transducer must always be handled as a delicate item. Wrongful actions may damage the transducer beyond repair.

Observe these rules:

- **Do not** activate the transducer when it is out of the water.
- **Do not** lift the transducer by the cable.
- **Do not** step on the transducer cable.
- **Do not** handle the transducer roughly, avoid impacts.
- **Do not** expose the transducer to direct sunlight or excessive heat.
- **Do not** use high pressure water, sand blasting, metal tools or strong solvents to clean the transducer face.

Procedure

- 1 Obtain the necessary lifting equipment, and make sure that the equipment is certified for the weight.
- 2 Lift the unit out of the transportation box.
- 3 Place it in a stable position on the floor/work bench.
- 4 Inspect the unit for visual damage.
- 5 Remove any packing material that may be inside the unit.
- 6 Collect and keep the relevant user manuals and/or documents provided with the unit.

Related topics

[Unpacking standard parts and units, page 198](#)

Unpacking electronic and electromechanical units

Prior to installation or use, electronic and electromechanical units must be unpacked from their transport boxes. It is important that this unpacking is done without inflicting damage to the equipment.

Prerequisites

Observe the procedure for unpacking of standard parts and units.

Context

Electronic and electromechanical units will normally be wrapped in a clear antistatic plastic bag.

Do not break the seal to open a circuit board package before the board is to be used. If the board package is returned to the manufacturer with the seal broken, the contents will be assumed to have been used and the customer will be billed accordingly.

Note

When you handle electronic circuit boards and modules, you must beware of the dangers of electrostatic discharge (ESD), both to yourself and to the equipment. In order to ensure safe transport and storage, circuit boards and other electronic units will always be wrapped in a clear plastic protective bag, and the bag will be sealed.

Procedure

- 1 Lift the unit, in its bag, out of the box.

Note

*Cables must **never** be used as carrying handles or lifting points.*

- 2 Place it in a stable position on the floor or a work bench.
- 3 Inspect the unit for visual damage before opening the antistatic plastic bag.
- 4 Assuming all is well, open the bag and remove the unit.
- 5 If applicable, open the unit and check inside.
- 6 Remove any packing and desiccant material that may be inside the unit.
- 7 Collect and keep the relevant user manuals and/or documents provided with the unit.

Related topics

[Unpacking standard parts and units, page 198](#)

Unpacking transducers

Prior to installation or use, sonar heads and hydrophones must be unpacked from their transport boxes. It is important that this unpacking is done without inflicting damage to the equipment.

Prerequisites

Observe the procedure for unpacking of standard parts and units.

Context

Transducers may be supplied mounted to a hull unit (if any), or packed separately. Sonar heads and hydrophones are normally packed and shipped in separate boxes. Boxes are identified by the order number and the serial number of the unit inside.

Note

Once a transducer, sonar head or hydrophone is unpacked, make sure that the body and the cabling are not exposed to any mechanical stress. Protect the transducer face with a padded cover plate to prevent damage.

Transducers may be heavy.

A transducer must always be handled as a delicate item. Wrongful actions may damage the transducer beyond repair.

Observe these rules:

- **Do not** activate the transducer when it is out of the water.
- **Do not** lift the transducer by the cable.
- **Do not** step on the transducer cable.
- **Do not** handle the transducer roughly, avoid impacts.
- **Do not** expose the transducer to direct sunlight or excessive heat.
- **Do not** use high pressure water, sand blasting, metal tools or strong solvents to clean the transducer face.

Procedure

- 1 Obtain the necessary lifting equipment, and make sure that the equipment is certified for the weight.
- 2 Lift the transducer, sonar head or hydrophone out of the transportation box.
- 3 Place it in a stable position on the floor/work bench.
- 4 Inspect the unit for visual damage.
- 5 Make sure that the relevant protection is kept in place until the final stages of the installation.
- 6 Collect and keep the relevant user manuals and/or documents provided with the unit.

7 Observe the handling rules for transducers.

Related topics

[Unpacking standard parts and units, page 198](#)

Specifications for storage after unpacking

The unit must whenever possible be stored in its original transportation crate until ready for installation.

General specifications

During storage, each box must not be used for any purpose for which it was not intended (work platform, table, steps etc.).

Once unpacked, all equipment must be kept in a dry, non condensing atmosphere, free from corrosive agents and isolated from sources of vibration.

Note

Do not break the seal to open a circuit board package before the board is to be used. If the board package is returned to Kongsberg Maritime with the seal broken, we will assumed that the unit has been used, and the you will be billed accordingly.

Each unit must be installed in its intended operating position as soon as possible after unpacking. If the unit contains normal batteries, these may have been disconnected/isolated before the unit was packed. These must then be reconnected during the installation procedure. Units containing batteries are marked.

Caution

Units containing lithium or alkaline batteries must be handled separately and with care. Such units are marked accordingly. Do not attempt to recharge such batteries, open them, or dispose of them by incineration.

Refer to the applicable product data sheets or battery handling procedures for further details.

Temperature protection

Any units that requires protection against extreme temperatures are identified as such in the applicable documentation. The box used to transport and store such units are clearly marked, for example:

Must not be transported or stored in temperatures below -5 °Celsius.

Other temperature limits may be used if applicable.

If a unit needs temperature protection, the box to be used for storage and transportation must be lined on all walls, base and lid, using minimum 5 cm thick polyurethane or polystyrene foam.

Most system units can normally be stored in temperatures between -30°C and $+70^{\circ}\text{C}$. Refer to the relevant technical specifications for details.

Note _____

Unless otherwise specified, transducers and hydrophones must not be stored in temperatures below -10°C and above $+50^{\circ}\text{C}$.

Packing instructions for storage or shipping

If a unit needs to be packed for storage or shipment, you must whenever possible use its original packing material and/or crate.

Context

In the event that the original packing material is unavailable, observe this basic procedure. It applies to all cabinets, large or small units, and mechanical items.

Note that a dedicated procedure applies for circuit board handling and packaging.

Any units that requires protection against extreme temperatures are identified as such in the applicable documentation. The box used to transport and store such units are clearly marked, for example:

Must not be transported or stored in temperatures below -5°C .

Other temperature limits may be used if applicable.

If a unit needs temperature protection, the box to be used for storage and transportation must be lined on all walls, base and lid, using minimum 5 cm thick polyurethane or polystyrene foam.

Most system units can normally be stored in temperatures between -30°C and $+70^{\circ}\text{C}$. Refer to the relevant technical specifications for details.

Note _____

Unless otherwise specified, transducers and hydrophones must not be stored in temperatures below -10°C and above $+50^{\circ}\text{C}$.

Procedure

- 1 Clean and protect the unit as described in the relevant procedures.
- 2 Place the unit in a suitable cardboard box or wooden crate.

- 3 Make sure that the unit is well be protected against physical damage by means of shock-absorbing insulation mats.
- 4 Take the necessary precautions if the unit must be protected against high or low temperatures, and mark the box accordingly.
- 5 Mark the box clearly to identify its contents.
- 6 Stored the box in a dry and dust-free area.

Related topics

[Transporting Kongsberg Maritime equipment, page 193](#)

[Lifting units and transportation boxes, page 194](#)

[Circuit board unpacking and handling, page 207](#)

[Returning a printed circuit board or an electronic module to Kongsberg Maritime, page 208](#)

[About Electrostatic Discharge \(ESD\), page 209](#)

Storage after use

If a unit is removed from its operating location and placed into storage, it must be properly cleaned and prepared before packing.

Topics

[Cleaning an electronic cabinet or unit, page 204](#)

[Cleaning a mechanical or electromechanical unit, page 205](#)

Cleaning an electronic cabinet or unit

If an electronic cabinet has been exposed to salt atmosphere, it must be thoroughly cleaned both internally and externally to prevent corrosion.

Prerequisites

In order to clean an electronic cabinet or unit, you will need relevant tools and detergents. You will also need some amount of desiccant material.

Procedure

- 1 Wipe off the external surfaces of the unit using a damp lint free cloth and a mild detergent.

Note

Do not use excessive amounts of water. The unit may not be water tight.

- 2 On completion, dry the unit thoroughly.
- 3 Inspect all surfaces for signs of corrosion, flaking, bubbling paint, stains etc.
- 4 Clean damaged or suspect areas, prepare and preserve these areas using the correct preservation mediums.
- 5 Open the unit.
- 6 Use a dedicated vacuum cleaner with an anti static nozzle to remove all dust from inside the unit.

Note _____

Use extreme care with delicate circuit boards and units. Make sure that these are not damaged in the process.

- 7 Wipe clean all exposed cables, and check for damage.
If a cable shows signs of wear or ageing, contact Kongsberg Maritime for advice.
- 8 Check if the unit contains batteries.
If the unit contains batteries, these may discharge slowly during storage. If the unit is to be stored for an extended period, disconnect or remove all internal batteries.
A suitable piece of insulating material can be placed between the battery and the electrical contacts to prevent electrical discharge. The battery can then remain in the unit, reducing the risk of it being misplaced during the storage period.
Caution _____
Units containing lithium or alkaline batteries must be handled separately and with care. Such units are marked accordingly. Do not attempt to recharge such batteries, open them, or dispose of them by incineration.
Refer to the applicable product data sheets or battery handling procedures for further details.
- 9 Place a suitably sized bag of desiccant material (silica gel or similar) into the unit to keep the electronic components as dry as possible.
- 10 Close the cabinet firmly before storage and/or shipment.
- 11 Secure and protect loose parts (shock absorbers, plug and sockets, protruding objects etc).
- 12 If the electronic cabinet shall be sent to storage or shipped, spray it externally using a corrosion inhibitor (for example a light oil) prior to packing.

Cleaning a mechanical or electromechanical unit

If an mechanical unit has been exposed to a salt atmosphere, it must be thoroughly cleaned to prevent corrosion.

Prerequisites

In order to clean a mechanical or electromechanical unit, you will need relevant tools and detergents.

Procedure

- 1 Wipe off the external surfaces of the mechanical unit using a damp lint free cloth and a mild detergent.

Note

Do not use excessive amounts of water. The unit may include parts that are not water tight.

- 2 On completion, dry the unit thoroughly.
- 3 Inspect all surfaces for signs of corrosion, flaking, bubbling paint, stains etc.
- 4 Clean damaged or suspect areas, prepare and preserve these areas using the correct preservation mediums.
- 5 Wipe clean all exposed cables, and check for damage.
If a cable shows signs of wear or ageing, contact Kongsberg Maritime for advice.
- 6 Secure and protect loose parts (shock absorbers, plug and sockets, protruding objects etc).
- 7 If the mechanical unit shall be sent to storage or shipped, spray it externally using a corrosion inhibitor (for example a light oil) prior to packing.
- 8 If relevant, place a suitably sized bag of desiccant material (silica gel or similar) into the to storage/transport box to keep the components as dry as possible.

Handling instructions for printed circuit boards and electronic modules

Printed circuit boards and electronic modules are delicate items. They may work year after year in an advanced product, but then fail due to a small spark of static electricity. For this reason, it is very important that they are properly handled and protected during shipping.

Topics

[Circuit board unpacking and handling, page 207](#)

[Returning a printed circuit board or an electronic module to Kongsberg Maritime, page 208](#)

[About Electrostatic Discharge \(ESD\), page 209](#)

Circuit board unpacking and handling

It is very important that printed circuit boards and other electronic modules are handled correctly.

Prerequisites

For correct and safe handling of printed circuit boards and electronic modules, you will need a suitable workbench with an approved conductive service mat. This service mat must be connected directly to a reliable earth point via its earthing cord. You must wear a wristband in direct contact with the skin, and the wristband must be connected to the service mat.

Sensitive printed circuit boards and electronic modules must always be transported and stored in protective antistatic packing bags. The circuit boards and modules must not be transported or stored close to strong electrostatic, electromagnetic or radioactive fields.

Context

Beware of electrostatic discharge (ESD)!

Note

When you handle electronic circuit boards and modules, you must beware of the dangers of electrostatic discharge (ESD), both to yourself and to the equipment. In order to ensure safe transport and storage, circuit boards and other electronic units will always be wrapped in a clear plastic protective bag, and the bag will be sealed.

Procedure

- 1 Prepare a suitable workbench with a conductive service mat.
- 2 Make sure that you wear a grounded wristband with direct contact with the skin

When you are working on board a vessel, an “approved conductive service mat” is often far away. As you still need to unpack circuit boards, make sure that you do it in the instrument room, or at another location where you have a steel deck.

Note

Keep far away from the bridge or any other rooms with wall-to-wall carpets!

If possible, bring a wristband and ground yourself.

- 3 Lift the circuit board, in its protective antistatic packing bag, out of the transport box.
- 4 Place it in a stable position on the workbench.
- 5 Inspect the unit for damage before you open the plastic bag.

- 6 Do not break the seal to open a printed circuit board or electronics module package before the item shall to be used.

Important _____

If the package is returned with the seal broken, we will assume that the content has been used. You will then be billed accordingly.

- 7 Assuming all is well, open the bag and remove the unit.
- 8 Take out and keep the documentation.
You will need the documentation if the circuit board or module shall be returned to us.
- 9 Remove any packing and desiccant material that may be inside.
- 10 Keep the protective antistatic packing bag for future use.

Related topics

[Transporting Kongsberg Maritime equipment, page 193](#)

[Packing instructions for storage or shipping, page 203](#)

[Returning a printed circuit board or an electronic module to Kongsberg Maritime, page 208](#)

[About Electrostatic Discharge \(ESD\), page 209](#)

Returning a printed circuit board or an electronic module to Kongsberg Maritime

If you wish to return a printed circuit board or an electronic module to us – either operational or defective – certain rules apply.

Prerequisites

For correct and safe handling of printed circuit boards and electronic modules, you will need a suitable workbench with an approved conductive service mat. This service mat must be connected directly to a reliable earth point via its earthing cord. You must wear a wristband in direct contact with the skin, and the wristband must be connected to the service mat.

Sensitive printed circuit boards and electronic modules must always be transported and stored in protective antistatic packing bags. The circuit boards and modules must not be transported or stored close to strong electrostatic, electromagnetic or radioactive fields.

Context

Beware of electrostatic discharge (ESD)!

When you handle electronic circuit boards and modules, you must beware of the dangers of electrostatic discharge (ESD), both to yourself and to the equipment. In order to

ensure safe transport and storage, circuit boards and other electronic units will always be wrapped in a clear plastic protective bag, and the bag will be sealed.

Note

Failure to follow these rules may result in unserviceable circuit boards.

Procedure

- 1 Place the circuit board to be returned in the same protective antistatic packing bag as you originally received it in - or in a protective bag of similar electrostatic discharge (ESD) protection quality.

Note

DO NOT use standard plastic bags, such as commercial bubble wrap.

- 2 Fill in all the necessary information on the applicable documentation and place it inside the bag.
- 3 Seal the bag.
- 4 Place the circuit board in a suitable carton, and secure it for shipping.

Related topics

[Packing instructions for storage or shipping, page 203](#)

[Circuit board unpacking and handling, page 207](#)

[About Electrostatic Discharge \(ESD\), page 209](#)

About Electrostatic Discharge (ESD)

Electrostatic discharge (ESD) is the sudden flow of electricity between two electrically charged objects. Such flow can be caused by contact, an electrical short, or dielectric breakdown. ESD can cause serious damage to printed circuit boards and electronic modules.

Beware of Electrostatic Discharge (ESD)!**Note**

When you handle electronic circuit boards and modules, you must beware of the dangers of electrostatic discharge (ESD), both to yourself and to the equipment. In order to ensure safe transport and storage, circuit boards and other electronic units will always be wrapped in a clear plastic protective bag, and the bag will be sealed.

For correct and safe handling of printed circuit boards and electronic modules, you will need a suitable workbench with an approved conductive service mat. This service mat must be connected directly to a reliable earth point via its earthing cord. You must

wear a wristband in direct contact with the skin, and the wristband must be connected to the service mat.

What is Electrostatic Discharge (ESD)?

Electrostatic Discharge (ESD) is the transfer of an electrostatic charge between two bodies at different electrostatic levels, caused either by direct contact or induction by an electrostatic field.

The passing of a charge through an electronic device can cause local overheating, and it can also “puncture” insulating layers within the structure of the device. This may deposit a conductive residue of the vaporized metal on the device, and thus create a short circuit.

This may result in a failures or degraded performance of the device.

ESD can create spectacular electric sparks (thunder and lightning is a large-scale ESD event), but also less dramatic forms which may be neither seen nor heard, yet still be large enough to cause damage to sensitive electronic devices. Electric sparks require a field strength above approximately 4 kV/cm in air, as notably occurs in lightning strikes. Other forms of ESD include corona discharge from sharp electrodes and brush discharge from blunt electrodes.

ESD can cause a range of harmful effects of importance in industry, including gas, fuel vapour and coal dust explosions, as well as failure of solid state electronics components such as integrated circuits. These can suffer permanent damage when subjected to high voltages. Electronics manufacturers therefore establish electrostatic protective areas free of static, using measures to prevent charging, such as avoiding highly charging materials and measures to remove static such as grounding human workers, providing antistatic devices, and controlling humidity.

http://en.wikipedia.org/wiki/Electrostatic_discharge (January 2014)

Precautions to prevent Electrostatic Discharge (ESD)

Sensitive printed circuit boards and electronic modules must always be transported and stored in protective antistatic packing bags. The circuit boards and modules must not be transported or stored close to strong electrostatic, electromagnetic or radioactive fields.

If it is necessary to open and touch the printed circuit board or module inside the protective bag, the following precautions must be taken:

- 1 The working area must be covered by an approved conductive service mat that has a resistance of between 50 k Ω and 2 M Ω , and is connected directly to a reliable earth point via its earthing cord.
- 2 You - and all other service personnel involved - must wear a wristband in direct contact with the skin. The wristband must be electrically connected to the service mat.
- 3 Printed circuit boards and electronic modules must be placed on the conductive service mat during installation and maintenance operations.

- 4 If, for any reason, it is necessary to move the circuit board from the conductive service mat, it must be placed in an approved antistatic transportation container (for example a static shielding bag) before transportation.
- 5 During installation and servicing, all electrical equipment (for example soldering irons and test equipment) must be earthed.

Related topics

[Packing instructions for storage or shipping, page 203](#)

[Circuit board unpacking and handling, page 207](#)

[Returning a printed circuit board or an electronic module to Kongsberg Maritime, page 208](#)

Disposal of old products

At the end of the product lifetime, all Kongsberg Maritime products must be disposed of in an environmentally-friendly way.

All electrical and electronic components must be disposed of separately from the municipal waste stream via designated collection facilities appointed by the government or local authorities. The correct disposal and separate collection of your old appliance will help prevent potential negative consequences for the environment and human health. This is a precondition for reuse and recycling of used electrical and electronic equipment. For more detailed information about disposal of your old appliance, please contact your local authorities or waste disposal service.

All disposal of mechanical, electromechanical, electronic and chemical waste - including all types of batteries - must take place according to national and international rules and regulations. Observe the relevant Waste Electrical and Electronic Equipment (WEEE) regulations.

Product recycling service

Kongsberg Maritime offers a product recycling service. The service is described on our website.

- <http://www.km.kongsberg.com>

Observe the following path: **Products**→**Services**→**Product recycling**.

We accept all Kongsberg Maritime products for recycling free of charge. The cost of having products removed, packed and delivered to a Kongsberg Maritime registered company location is, however, not covered by us. Prior to returning any material please contact us for information about a relevant return address and procedure for your product.

Kongsberg Maritime has implemented and maintains an environmental management system in accordance with NS-EN ISO 14001:2004.

Topics

©2015 Kongsberg Maritime

**Simrad EK60 Scientific echo sounder
Installation manual**

**Simrad EK60 Scientific echo sounder
Installation manual**

**Simrad EK60 Scientific echo sounder
Installation manual**