



KONGSBERG

HiPAP 502P
502P/452P system
Instruction Manual

440337/A

August 2018 © Kongsberg Maritime AS

Document information

- **Product:** Kongsberg HiPAP 502P
- **Document:** Instruction Manual
- **Document part number:** 440337
- **Revision:** A
- **Date of issue:** August 2018

Copyright

The information contained in this document remains the sole property of Kongsberg Maritime AS. No part of this document may be copied or reproduced in any form or by any means, and the information contained within it is not to be communicated to a third party, without the prior written consent of Kongsberg Maritime AS.

Warning

The equipment to which this manual applies must only be used for the purpose for which it was designed. Improper use or maintenance may cause damage to the equipment and/or injury to personnel. You must be familiar with the contents of the appropriate manuals before attempting to operate or work on the equipment.

Kongsberg Maritime disclaims any responsibility for damage or injury caused by improper installation, use or maintenance of the equipment.

Disclaimer

Kongsberg Maritime AS endeavours to ensure that all information in this document is correct and fairly stated, but does not accept liability for any errors or omissions.

Support information

If you require maintenance or repair, contact Kongsberg Maritime's support organisation. You can also contact us using the following address: km.support.hpr@kongsberg.com. If you need information about our other products, visit <https://www.km.kongsberg.com>.

Table of contents

ABOUT THIS MANUAL	7
KONGSBERG HIPAP 502P	8
System description.....	9
System diagram.....	10
System units.....	11
Computer.....	11
Transceiver.....	11
Responder Driver Unit (optional).....	12
APOS - the HiPAP operator system.....	12
HiPAP 500 Portable transducer.....	12
General supply conditions.....	12
Receipt, unpacking and storage.....	13
Equipment responsibility.....	13
Support information.....	13
INSTALLATION	15
Installing the computer in a 19" rack.....	16
Installing the computer with a KM1000 kit.....	16
Installing the transceiver.....	17
Installing the Responder Driver Unit.....	18
CABLE LAYOUT AND INTERCONNECTIONS	20
Cable plan.....	21
List of cables.....	22
Yard/customer responsibilities for installation of HiPAP 502P computer.....	23
Installing the HiPAP 502P topside cables.....	23
Computer rear connectors.....	25
Connecting power and ground to the transceiver.....	26
Connecting the transducer to the transceiver.....	28
Connect the cable from the transceiver to the Responder Driver Unit.....	29
Connecting the Responder Driver Unit to the responder.....	31
Converting from fibre optical to electrical signal.....	32
OPERATING PROCEDURES	33
TECHNICAL SPECIFICATIONS	34
Performance specifications.....	35
Weight and outline dimensions.....	36
Power specifications.....	37
Environmental requirements.....	38

MAINTENANCE	39
About Electrostatic Discharge (ESD)	40
Preventive maintenance schedule	42
Computer	42
Replacing the filter	42
Preventive maintenance intervals	44
Backup	44
Transceiver unit.....	44
Replacing the Ethernet switch/Converter	44
Removing the LPT32 Transceiver board	45
Replacing a circuit board.....	46
Removing a filter board.....	47
Replacing a filter board	48
Removing the power module from the transceiver unit	48
Replacing the power module in the transceiver unit	49
Replacing the fan unit in the transceiver unit.....	49
Replacing the terminal block in the transceiver unit.....	50
Replacing a fuse in the transceiver unit.....	50
SPARE PARTS	52
Computer	53
HiPAP 500 transducer.....	53
Transceiver unit.....	53
LPT32 Transceiver board Spare part	54
LPT32 Filter board Spare part	54
Power supply Spare part	54
Ethernet switch Spare part	54
Fan unit Spare part.....	54
DRAWING FILE.....	55
MP5810 Computer.....	56
Transceiver unit - Outline dimensions	57
435248 Transceiver unit - Wiring diagram	58
433851 Transducer dimensions	59
433953 Sensor reference point.....	60
Responder driver unit, outline dimensions	61
Responder driver unit, wiring diagram	62
Fibre to responder drive converter, wiring diagram	63
EQUIPMENT HANDLING.....	64
Inspection of units and transportation boxes after arrival.....	65
Unpacking standard parts and units	65
Specifications for storage after unpacking.....	67

Transporting Kongsberg Maritime equipment.....68

About this manual

The purpose of this manual is to provide the descriptions, procedures and detailed parameter explanations required to allow for safe and efficient use of the HiPAP 502P.

Target audience

This manual is intended for all users of the HiPAP 502P.

Online information

All end-user manuals provided for operation and installation of your HiPAP 502P can be downloaded from our website.

- <https://www.km.kongsberg.com>

Registered trademarks

Observe the registered trademarks that apply.

Windows® is a registered trademark of Microsoft Corporation in the United States and other countries.

HiPAP® is a registered trademark of Kongsberg Maritime AS in Norway and other countries.

cNODE® is a registered trademark of Kongsberg Maritime AS in Norway and other countries.

Kongsberg HiPAP 502P

Topics

[System description, page 9](#)

[System diagram, page 10](#)

[System units, page 11](#)

[General supply conditions, page 12](#)

[Support information, page 13](#)

System description

The HiPAP 502P system is designed for optimal positioning of subsea objects in both shallow and deep water.

The HiPAP 502P systems provides accurate positions of subsea objects such as Remotely operated vehicles (ROVs), Autonomous underwater vehicles (AUV's), towed bodies or fixed seabed transponders.

The system is offering the user a wide range of transponder channels and cNODE transponder models for depths rating down to 11000 metres.

HiPAP Portable is available in several models with respect to motion and heading sensors. These models have no need for calibration of roll and pitch alignments, but might need to calibrate for alignment to the vessels' gyro compass. The transducers are designed to be mounted on a shaft for installation over-the-side or through a moon-pool of a vessel.

System diagram

The system diagram identifies the main components of a basic HiPAP 502P system. Only the main connections between the units are shown. Detailed interface capabilities and power cables are not shown.

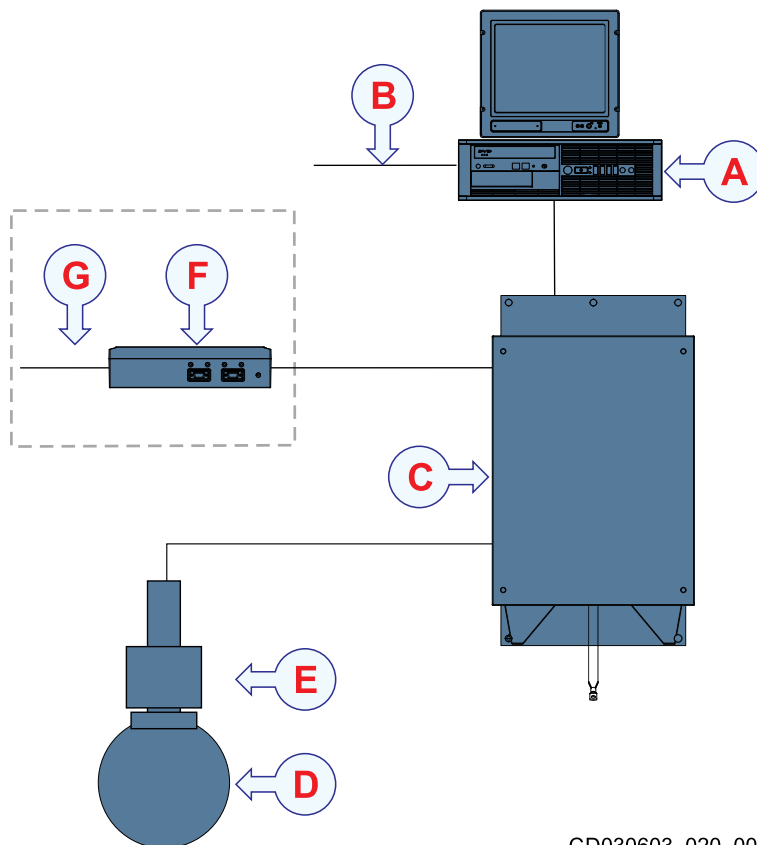

CD030603_020_001

- A** *Computer*
- B** *Interfaces*
 - *Attitude (roll, pitch and heave)*
 - *Heading*
 - *Positioning systems*
- C** *transceiver*
- D** *Transducer*
- E** *Motion and heading sensor*
- F** *Responder Driver Unit (optional)*
- G** *Responder*

System units

Computer

The HiPAP system is operated through either one or several operator stations or computers.

The computer consists of the following main units:

- Computer
- Display
- Keyboard and mouse

Computer

The computer is an 8 channel serial line model. It is built on a high performance CPU running a Microsoft Windows 7 operating system. The computer can be installed inside operator station consoles by using specific brackets or as a stand alone unit.

Display

Refer to the separate manual supplied with the display.

Keyboard and mouse

The keyboard is a USB QWERTY keyboard with US layout. The mouse is optical with cable and USB connection.

Transceiver

The transceiver is provided to transmit acoustic energy through water. To do this, the transceiver computes and generates the electric signals sent to the transducer to form a transmission - a "ping". After each transmission, the transceiver receives the echoes from the targets in the water and/or the seabed. These echoes are filtered and amplified, and then converted to digital format.

The transceiver is a stainless steel cabinet that contains racks holding the system electronic modules. It contains a number of circuit boards and modules. The transceiver is designed to be installed on a suitable bulkhead and are fitted with vibration/shock absorbers to reduce the effects of vessel vibrations.



Responder Driver Unit (optional)

The Responder Driver Unit provides responder trigger signals to responders.

The Responder Driver Unit is a stand-alone unit. The unit is interfaced to the HiPAP system via the transceiver unit. APOS controls which drive is being active while the sync/timing is received from the transceiver.



APOS - the HiPAP operator system

The HiPAP system is operated from an acoustic positioning operator station (APOS). The operator station is a Windows based computer running dedicated acoustic positioning software.

The system can be operated from one single APOS station or from a wide number of APOS operator stations connected on a network.

HiPAP 500 Portable transducer

The transducer is portable and has an integrated motion sensor. Several models are available with different motion and heading sensors.

The HiPAP 500 Portable transducer has a full spherical body that includes 241 transducer elements. The HiPAP 450 has the same transducer with disabled elements. The sensors are inside the unit that is attached to the top of the transducer.



General supply conditions

The following general supply conditions apply to this Kongsberg HiPAP 502P delivery.

Related topics

[Inspection of units and transportation boxes after arrival, page 65](#)

[Unpacking standard parts and units, page 65](#)

[Specifications for storage after unpacking, page 67](#)

[Transporting Kongsberg Maritime equipment, page 68](#)

Receipt, unpacking and storage

Upon accepting shipment of the equipment, the shipyard and/or the dealer must ensure that the delivery is complete and inspect each shipping container for evidence of physical damage.

If the inspection reveals any indication of crushing, dropping, immersion in water or any other form of damage, the recipient should request that a representative from the company used to transport the equipment be present during unpacking.

All equipment must be inspected for physical damage, i.e. broken controls and indicators, dents, scratches etc. during unpacking. If any damage to the equipment is discovered, the recipient must notify both the transportation company and Kongsberg Maritime so that Kongsberg Maritime can arrange for replacement or repair of the damaged equipment.

Once unpacked, the equipment must be stored in a controlled environment with an atmosphere free of corrosive agents, excessive humidity or temperature extremes.

The equipment must be covered to protect it from dust and other forms of contamination when stored.

Equipment responsibility

Unless otherwise stated in the contract, the shipyard doing the installation and/or equipment dealer becomes fully responsible for the equipment upon receipt.

The duration of responsibility cover:

- The period of time the equipment is stored locally before installation
- The entire installation process
- Commissioning
- The period of time between commissioning and the final acceptance of the equipment by the end user or owner

Unless other arrangements have been made in the contract, the Kongsberg HiPAP 502P warranty period (as specified in the contract) begins when the acceptance documents have been signed.

Support information

Should you need technical support for your HiPAP 502P you must contact a Kongsberg Maritime office. A list of all our offices is provided on our website. You can also contact our main support office in Norway.

- **Company name:** Kongsberg Maritime AS
- **Address:** Strandpromenaden 50, 3190 Horten, Norway
- **Telephone:** +47 33 03 41 00

- **Telephone 24h support:** +47 33 03 24 07
- **Telefax:** +47 33 04 76 19
- **Website:** <http://www.km.kongsberg.com>
- **Support website:** http://www.km.kongsberg.com/support_hpr
- **E-mail address:** km.support.hpr@kongsberg.com

Installation

Topics

[Installing the computer in a 19" rack, page 16](#)

[Installing the computer with a KM1000 kit, page 16](#)

[Installing the transceiver, page 17](#)

[Installing the Responder Driver Unit, page 18](#)

Installing the computer in a 19" rack

The computer can be installed inside a console, inside a suitable cabinet, in a 19" rack or on a desk. This procedure describes how to install the computer using rack kit 371931.

Context

Procedure

- 1 Remove the lid from the rack shelf.
- 2 Place the computer on the shelf with the front to the front of the shelf.
- 3 Mount the lid, and secure properly with the lock nuts and washers.
- 4 Mount the shelf to the rack with the cage nuts, washers and screws provided.

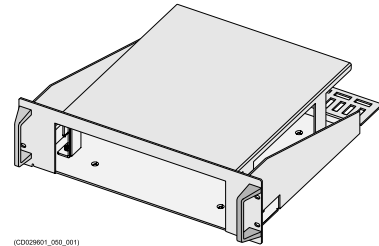

Further requirements

Connect the cables.

After electrical installation, secure all cables to cable fingers and holes.

Installing the computer with a KM1000 kit

The computer can be installed inside a console, inside a suitable cabinet, in a 19" rack or on a desk. This procedure describes how to install the computer using KM1000 kit (331385).

Prerequisites

Install the computer horizontal or vertical with the KM1000 kit.

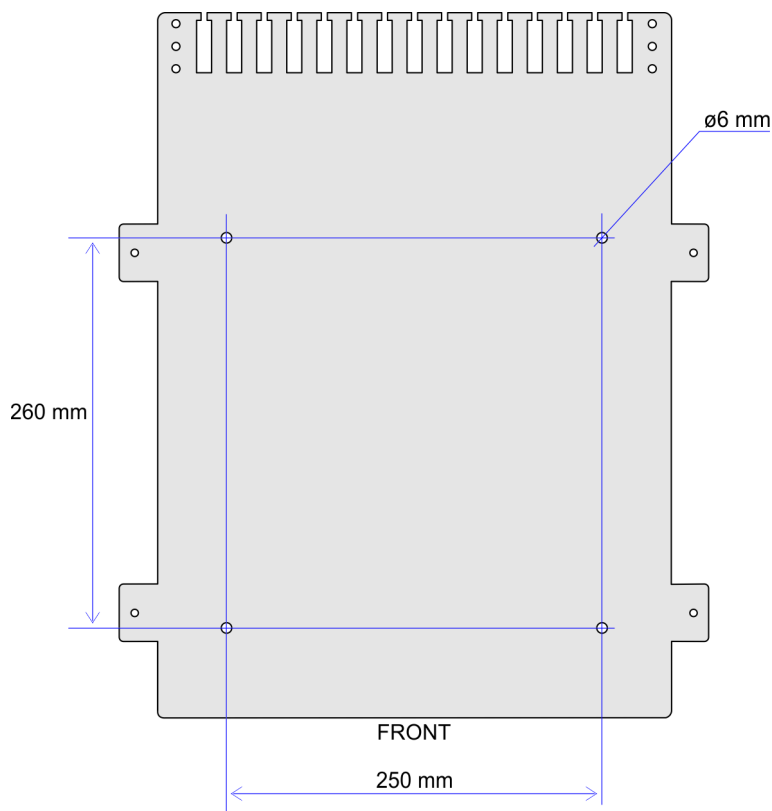

Procedure

- 1 Prepare four holes, each for M6, following the illustration.
- 2 Mount the bottom plate using countersunk screws or bolts.
- 3 Place the computer on the bottom plate.
- 4 Mount the two brackets to the bottom plate using M5 locking nuts and washers.

Further requirements

Connect the cables.

After electrical installation, secure all cables to cable fingers and holes.

Installing the transceiver

The physical length of the cables limit the distance between the transducer and the transceiver.

Prerequisites

There must be a clear space of at least 500 mm in front of the unit for maintenance and 200 mm under the unit for the cables.

The transceiver unit must be mounted on a bulkhead. You do not need to remove the circuit boards or modules from the transceiver unit during the installation process. Keep the transceiver unit door on during the installation. Make sure that the unit is not exposed to dust, moisture, vibration or physical damage during the installation process.

The brackets for hanging up the transceiver is delivered with the unit.

Caution

Do not weld in the vicinity of the transceiver unit. First weld the brackets, then bring in the transceiver unit.

Procedure

- 1 Measure and mark the locations where to mount the brackets.
Make sure the transceiver is at a suitable height for easy access.
- 2 Weld the brackets to the bulkhead.
- 3 Clean the welds and brackets, and paint them with an appropriate preservation medium.
- 4 Once the paint is dry, lift the unit into position and align the unit onto the brackets.
- 5 Start with the upper bracket, and bolt the shock absorbers to the brackets.

Further requirements

Connect the cables.

Related topics

[About Electrostatic Discharge \(ESD\), page 40](#)

Installing the Responder Driver Unit

The Responder Driver Unit provides responder trigger signals to responders. The RDU is a stand-alone unit and can be mounted horizontally or vertically.

Prerequisites

The unit should be located where it is most suitable for connecting the cables to the responders. This can be close to Remote Operating Vehicle (ROV) operation room. The unit must be installed so it is easy accessible for operators to check the working condition of the responder trigger status diodes.

Procedure

- 1 Open the unit by removing the four screws that secures the lid.
- 2 Lift off the lid and see the four mounting holes, one in each corner.

- 3 Mount the responder driver unit where suitable.
The mounting screws with nuts and washers are delivered with the unit.
- 4 Close the unit.

Cable layout and interconnections

Topics

[Cable plan, page 21](#)

[List of cables, page 22](#)

[Yard/customer responsibilities for installation of HiPAP 502P computer, page 23](#)

[Installing the HiPAP 502P topside cables, page 23](#)

[Computer rear connectors, page 25](#)

[Connecting power and ground to the transceiver, page 26](#)

[Connecting the transducer to the transceiver, page 28](#)

[Connect the cable from the transceiver to the Responder Driver Unit., page 29](#)

[Connecting the Responder Driver Unit to the responder, page 31](#)

[Converting from fibre optical to electrical signal, page 32](#)

Cable plan

The cables are part of the delivery with the main units.

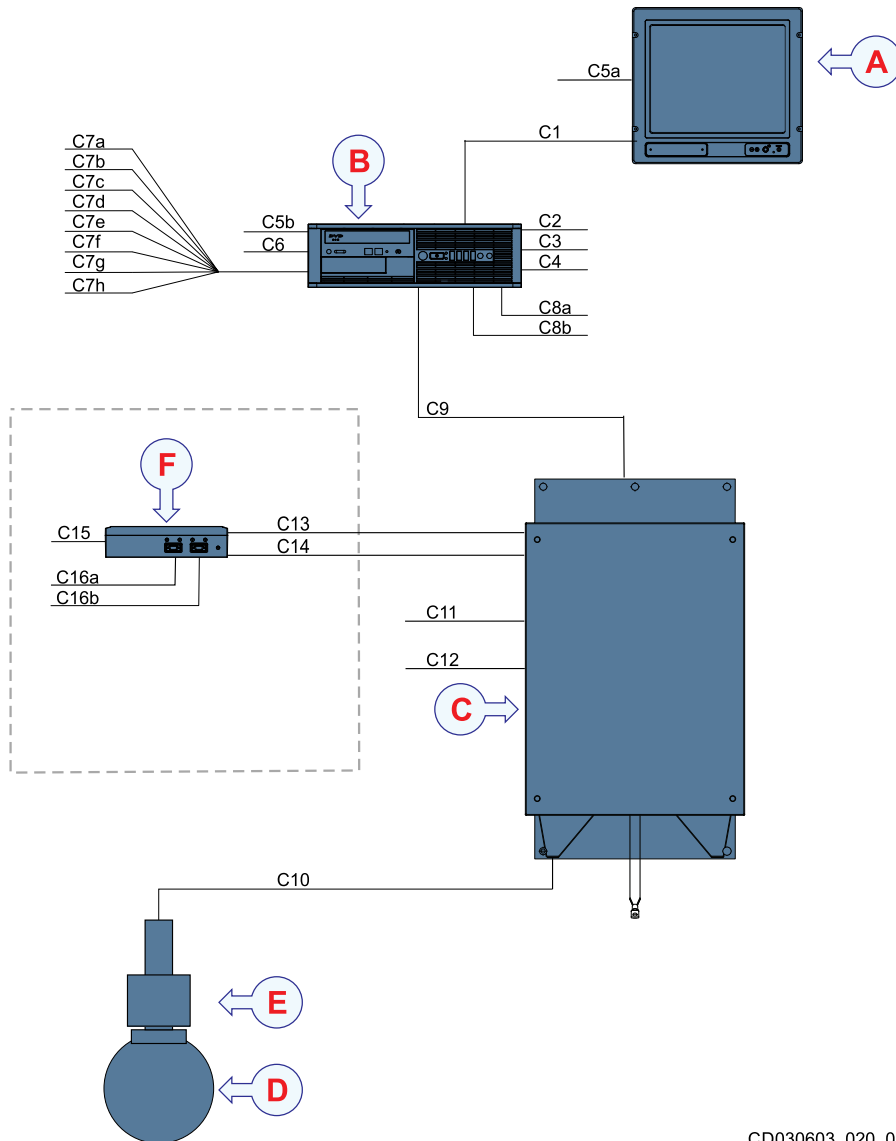

CD030603_020_002

- A** Display
- B** Computer
- C** transceiver
- D** Transducer
- E** Inertial Measurement Unit
- F** Responder Driver Unit (optional)

List of cables

A set of cables is required to connect the HiPAP 502P units to each other, and to the relevant power source(s).

Cable	Type	From/To	Minimum requirements
C1	Video cable	From computer to display	
C2	Computer cable	From computer to keyboard	
C3	Computer cable	From computer to mouse (or another similar device)	
C4	Serial cable	From computer to external device(s)	
C5 (a)	AC power cable	From display to AC power outlet	
C5 (b)	AC power cable	From computer to AC power outlet	
C6	Ground cable	From computer to vessel ground	
C7 (a)	Serial cable	From computer to external device(s)	Split cable 4x2x0.5 w/ screen
C7 (b)	Serial cable	From computer to external device(s)	Split cable 4x2x0.5 w/ screen
C7 (c)	Serial cable	From computer to external device(s)	Split cable 4x2x0.5 w/ screen
C7 (d)	Serial cable	From computer to external device(s)	Split cable 4x2x0.5 w/ screen
C7 (e)	Serial cable	From computer to external device(s)	Split cable 4x2x0.5 w/ screen
C7 (f)	Serial cable	From computer to external device(s)	Split cable 4x2x0.5 w/ screen
C7 (g)	Serial cable	From computer to external device(s)	Split cable 4x2x0.5 w/ screen
C7 (h)	Serial cable	From computer to external device(s)	Split cable 4x2x0.5 w/ screen
C8 (a)	Ethernet cable	From computer to local area network (LAN) A	Cat 7 * 100/ 1000 BaseTX port
C8 (b)	Ethernet cable	From computer to local area network (LAN) B	Cat 7 * 100/ 1000 BaseTX port
C9	Ethernet cable	From transceiver to computer	Cat 7 * 1000 BaseTX port
C10	Transducer cable	From transceiver to transducer	
C11	AC power cable	From transceiver to AC power outlet	
C12	Ground cable	From transceiver to vessel ground	
C13	Ethernet cable	From transceiver to Responder Driver Unit	

C14	Serial cable	From transceiver to Responder Driver Unit	
C15	AC power cable	From Responder Driver Unit to AC power outlet	
C16 (a)	Serial cable	From Responder Driver Unit to external device(s)	
C16 (b)	Serial cable	From Responder Driver Unit to external device(s)	

Yard/customer responsibilities for installation of HiPAP 502P computer

Yard/customer has to install one (1) double 115/230 VAC power sockets within 2 metres cabling distance from the computer. One (1) 115/230 VAC power cable of 2 metres length is delivered.

Yard has to install the patch panel for the system network (if delivered).

The serial number plate has to be mounted near by the computer (on the outside of the yard/customer supplied console/cabinet if the computer is mounted inside a console/cabinet).

Installing the HiPAP 502P topside cables

The topside/bridge cables include those used to connect the HiPAP 502P computer and the display to each other, to AC mains power, and to external devices. One high capacity Ethernet cable connects the computer to the transceiver.

Procedure

- 1 Connect the power cable from the display to the AC power outlet. (C5a)
- 2 Connect the power cable from the computer to the AC power outlet. (C5b)
- 3 Connect the cable from the computer to the keyboard. (C2)
- 4 Connect the cable from the computer to the mouse (or another similar device). (C3)
- 5 Connect the video cable from the computer to the display. (C1)
- 6 Connect the ground cable from the computer to vessel ground. (C6)
The cable must be provided by the installation shipyard.
- 7 Connect the Ethernet cable from the computer to the local area network (LAN). (C8 a, C8 b)
- 8 Connect the serial cables from the computer to the relevant external devices. (C7)

- 9 Connect the Ethernet cable from the computer to the transceiver. (C9)

Note _____

It is very important that a high quality Ethernet cable is used.

- 10 Connect the ground cable from the transceiver to vessel ground. (C12)
- 11 Connect the power cable from the RDU to the AC power outlet. (C15)
- 12 Connect the cable from the transceiver to the Responder Driver Unit. (C13, C14)
- 13 Connect the cable from the RDU to the external device.

Computer rear connectors

The rear panel on the computer holds connectors for the various HiPAP 502P cables.

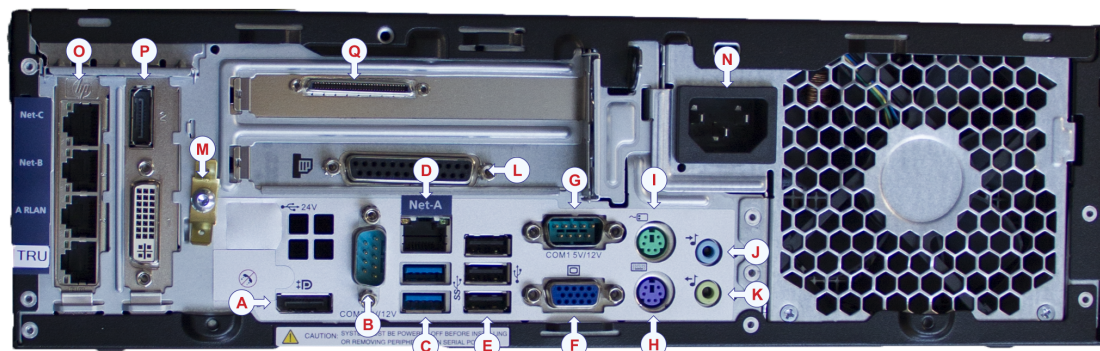

- A Display cable
- B Serial cable
- C USB cables
- D Ethernet cable
- E USB cables
- F Display cable
- G Serial cable
- H PS/2 keyboard cable
- I PS/2 mouse cable
- J Audio cable — Audio input
- K Audio cable — Audio output
- L Parallel cable
- M Ground cable
- N AC power cable
- O Ethernet cables
- P Video cables
- Q Special cable

Connecting power and ground to the transceiver

The transceiver must be connected to AC mains and it must be properly grounded.

Prerequisites

The transceiver is delivered with a power cable for test use only. The power cable must be provided by the yard.

Procedure

- 1 Produce the cable according to the specification.
- 2 Connect the cable between the power source and the transceiver.
- 3 Loosen the cable gland on the cable to the filter. The top part needs to be loosened, not the nut.

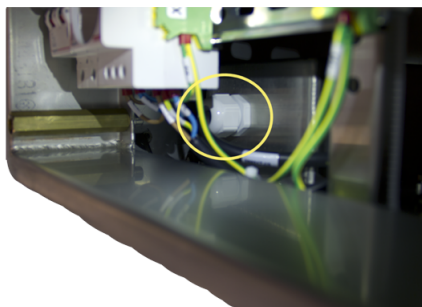

The cable gland is located near the bottom of the cabinet.

- 4 Remove the 16 screws on the power box underneath the transceiver cabinet.

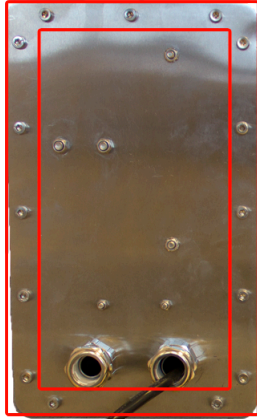

- 5 Take care not to lose the gasket around the box.

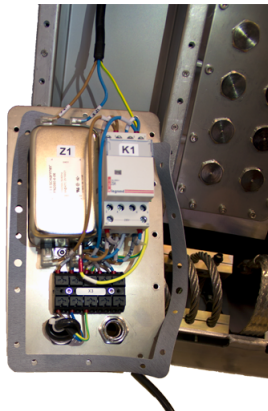

- 6 Remove the test cable.
- 7 Enter the cable through the gland, connecting it as shown in the wiring diagram and the cable description.

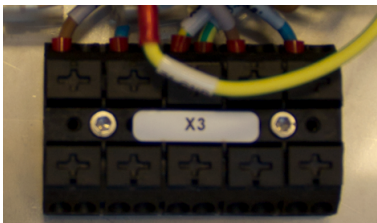

There are room for two individual power cables, for redundancy.

- 8 Block the cable gland not in use, if there is no redundancy in the power supply. Use a F/M20 cable gland blind plug.
- 9 Screw the power box back on with the gasket fitted.
- 10 Fasten the cable glands, both the one loosened and the one/s for the power cable/s.

- 11 Connect the grounding cable to ships ground.

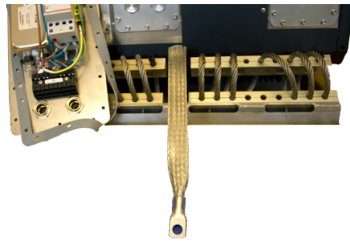

Connecting the transducer to the transceiver

The cable is physically connected to the transducer.

Prerequisites

Make sure this cable moves as smooth as possible without any unnecessary wear.

Procedure

- 1 Remove the blind cover from underneath the transceiver on the right side, keeping the screws for the cover and EMC gasket.

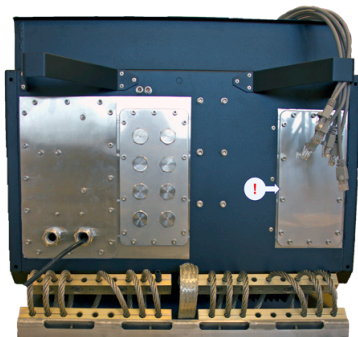

- 2 Insert the cable and connectors.



- 3 Fasten the cover.
- 4 Connect the individual transducer cables to the correct circuit board.

The connectors are numbered. Circuit board 1 is to the left following in sequence to board number 8 to the far right.

- 5 Bundle the cables to the bracket inside the transceiver unit.



- 6 Connect the power cable to the X2 +48 V terminal block according to the wiring diagram.
- 7 Connect the Ethernet cable to the MOXA switch.
- 8 Close the door.

Connect the cable from the transceiver to the Responder Driver Unit.

The synchronization cable for the Responder Driver Unit is provided by the yard.

Prerequisites

The 9-pin D-sub plug is delivered with the Responder Driver Unit.



(CD0801_004_005)

- A** Responder Driver Unit, **Input Responder Sync**
- B** Transceiver Unit, X2

Procedure

- 1 Select the cable according to the specification and cut it to the needed length.
- 2 Install the 9-pin D-sub plug to the cable.
- 3 Support the cable between the transceiver and the Responder Driver Unit, making sure the D-sub connector ends at the Responder Driver Unit.
- 4 Remove one of the blind plugs in the bottom of the cabinet.
- 5 Insert the cable through one of the cable glands delivered with the transceiver cabinet.
- 6 Connect the wires to terminal block X2 according to the cable drawing or the wiring diagram.

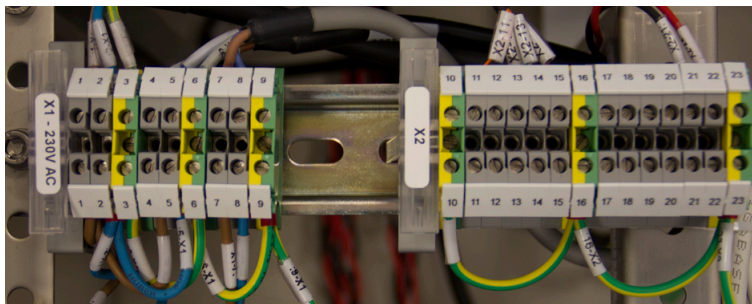

- 7 Provide a service loop on the cable and fasten the cable gland.
- 8 Connect the 9-pin D-sub plug to the **Input Responder Sync** connector on the Responder Driver Unit.

Connecting the Responder Driver Unit to the responder

The Responder Driver Unit provides responder trigger signals to responders. These cables must be provided by the installation shipyard.

Prerequisites

The signal cables to the responder consists of 2 dsusb connectors for electrical signals for responders 1–4.

Pinout Responder drive signal 1 to 4 for Responder Drive Unit	
Responder 1	9p D-sub
Power 1 +24V	1
Drive signal 1	2
Ground	3
Responder 2	9p D-sub
Power 2 +24V	6
Drive signal 2	7
Ground	8
Responder 3	9p D-sub
Power 3 +24V	1
Drive signal 1	2
Ground	3
Responder 4	9p D-sub
Power 4 +24V	6
Drive signal 2	7
Ground	8

RDU
Front view

Male 9-pin D-sub connector

CD0801_003_004

Procedure

- 1 Manufacture the cable.
- 2 Secure the cable from the responder driver unit to the responder.
Use a fibre to electrical signal converter if necessary.
- 3 Connect the cable.

Converting from fibre optical to electrical signal

The converter works both ways and can be used to create an optical isolation between high voltage equipment and a transceiver.

Context

You need one kit for each responder signal. The connectors are provided to make the cable as long as it needs to be.

Procedure

- 1 Produce the cable from the responder driver unit to the converter according to drawing 308850 in the drawing file chapter. The connectors are part of the converter kit.
- 2 Secure the cable and connect it.
- 3 For an optical isolation, produce the cable from the converter to the ROV according to drawing 308850 in the drawing file chapter. This connector is also provided.
- 4 Secure the cable and connect it.
- 5 Continue with fibre optical or electrical cables as needed.

Operating procedures

See APOS online help.

Technical specifications

Topics

[Performance specifications, page 35](#)

[Weight and outline dimensions, page 36](#)

[Power specifications, page 37](#)

[Environmental requirements, page 38](#)

Performance specifications

These performance specifications summarize the main functional and operational characteristics of the HiPAP 502P 502P/452P system.

	S/N [dB rel. 1μPa]		
	20	10	0
Angular Accuracy (X & Y direction) [°]	0.06	0.1	0.3
Position Accuracy [°] (At 0° elevation)	0.08	0.14	0.42
Range Accuracy [m]	0.1	0.1	0.15
Cymbal Range Accuracy [m]	0.02	0.02	0.02
Receiver beam [°]	10		
Coverage [°]	±100		

Angular Accuracy (X & Y direction) [°] is the accuracy in each of the x and y axes.

Position Accuracy [°] is the combined accuracy of both axes ($\sqrt{x^2 + y^2}$).

Transceiver unit

The HiPAP transceiver accepts the following input formats:

Gyro

- NMEA \$**HDT
- NMEA \$**VHW
- Yokogawa \$**HRC
- SKR
- STL

VRU/Attitude

- EM 3000
- \$SPSXN,10
- \$SPSXN,23
- IxSea Octans TAH (\$PHOCT) R-P-H (UTC)
- IxSea Octans \$PHTRO (roll and pitch)
- Ixsea Octans \$PHLIN (Heave only)

For attitude data, the data rate should be at least 25 Hz, 100 Hz is recommended.

Data input can be either serial line RS-232 / RS-422 or Ethernet UDP.

Serial line speeds can be from 1200 baud up to 115200 baud, 1 or 2 stop bits, 7/8 bit data and parity none, even or odd.

Weight and outline dimensions

These weights and outline dimension characteristics summarize the physical properties of the HiPAP 502P system.

Display

- **Model:** Hatteland Display JH19T14
- **Outline dimensions:**
 - **Depth:** 82 mm
 - **Width:** 483 mm
 - **Height:** 444 mm
- **Weight:** 11.5 kg

Computer

- **Model:** MP5810
- **Outline dimensions:**
 - **Depth:** 379 mm
 - **Width:** 338 mm
 - **Height:** 100 mm
- **Weight:** 7 kg

Transceiver Unit

- **Model:** x82
- **Outline dimensions:**
 - **Depth:** 525 mm
 - **Width:** 909 mm
 - **Height:** 548 mm
- **Weight:** 72 kg

Responder Driver Unit

- **Outline dimensions:**
 - **Depth:** 200 mm

- **Width:** 280 mm
- **Height:** 73 mm
- **Weight:** 2.8 kg

Transducer

- **Model:** HiPAP 500 Portable transducer
- **Outline dimensions:**
 - **Diameter:** 392 mm
 - **Height:** 749 mm
- **Weight:** 93 kg + cables

Related topics

[MP5810 Computer, page 56](#)

[Transceiver unit - Outline dimensions, page 57](#)

[Responder driver unit, outline dimensions, page 61](#)

Power specifications

These power characteristics summarize the supply power requirements for the HiPAP 502P system.

Computer

- **Model:** MP5810
- **Voltage requirement:** 110/220 VAC , 50/60 Hz autosensing, 240 W 85+ autosensing power
- **Maximum voltage deviation:** 15%
- **Maximum current draw:** 5 A
- **Normal current draw:** 0.5 A
- **Power consumption:** 150 W

Transceiver Unit

- **Make and model:** x82
- **Voltage requirement:** 115/230 VAC — 50/60 Hz
- **Immunity:** Fast transient burst EN61000-4-4 (4kV)
- **Maximum voltage deviation:** 15 %
- **Maximum current draw:** 40 A
- **Normal current draw:** 0.8 A

Responder Driver Unit

- **Voltage requirement:** 85 to 264 VAC — 40 to 440 Hz
- **Maximum inrush:** 5 A AC
- **Maximum current draw:** 0.4 A
- **Normal current draw:** 0.06 A
- **Power consumption:** 15 W

Environmental requirements

These environmental specifications summarize the temperature and humidity requirements for the HiPAP 502P 502P/452P system.

Computer

- **Model:** MP5810
- **Operational temperature:** 0 to +55 °C
- **Storage temperature:** -20 to 70 °C
- **Relative humidity:** 5 to 95% relative, non-condensing

Transceiver Unit

- **Ingress protection (IP) rating:** IP44
- **Vibration:** 5 to 100 Hz
- **Excitation level:** 5-13.2 Hz \pm 1.5 mm, 13.2-100 Hz 1 g
- **Operational temperature:** 0 to +55 °C
- **Storage temperature:** -20 to 65 °C
- **Relative humidity:** 15 to 95% relative non-condensing

Responder Driver Unit

- **Ingress protection (IP) rating:** IP44
- **Vibration:** 5 to 100 Hz
- **Excitation level:** 5 to 13.2 Hz \pm 1.5 mm, 13.2 to 100 Hz 1 g
- **Operational temperature:** 0 to +55 °C
- **Storage temperature:** -40 to 75 °C
- **Relative humidity:** 15 to 95% relative non-condensing

Maintenance

Topics

[About Electrostatic Discharge \(ESD\), page 40](#)

[Preventive maintenance schedule, page 42](#)

[Computer, page 42](#)

[Transceiver unit, page 44](#)

About Electrostatic Discharge (ESD)

Electrostatic discharge (ESD) is the sudden flow of electricity between two electrically charged objects. Such flow can be caused by contact, an electrical short, or dielectric breakdown. ESD can cause serious damage to printed circuit boards and electronic modules.

Beware of Electrostatic Discharge (ESD)!

Note

When you handle electronic circuit boards and modules, you must beware of the dangers of electrostatic discharge (ESD), both to yourself and to the equipment. In order to ensure safe transport and storage, circuit boards and other electronic units will always be wrapped in a clear plastic protective bag, and the bag will be sealed.

For correct and safe handling of printed circuit boards and electronic modules, you will need a suitable workbench with an approved conductive service mat. This service mat must be connected directly to a reliable earth point via its earthing cord. You must wear a wristband in direct contact with the skin, and the wristband must be connected to the service mat.

What is Electrostatic Discharge (ESD)?

Electrostatic Discharge (ESD) is the transfer of an electrostatic charge between two bodies at different electrostatic levels, caused either by direct contact or induction by an electrostatic field.

The passing of a charge through an electronic device can cause local overheating, and it can also “puncture” insulating layers within the structure of the device. This may deposit a conductive residue of the vaporized metal on the device, and thus create a short circuit.

This may result in a failures or degraded performance of the device.

ESD can create spectacular electric sparks (thunder and lightning is a large-scale ESD event), but also less dramatic forms which may be neither seen nor heard, yet still be large enough to cause damage to sensitive electronic devices. Electric sparks require a field strength above approximately 4 kV/cm in air, as notably occurs in lightning strikes. Other forms of ESD include corona discharge from sharp electrodes and brush discharge from blunt electrodes.

ESD can cause a range of harmful effects of importance in industry, including gas, fuel vapour and coal dust explosions, as well as failure of solid state electronics components such as integrated circuits. These can suffer permanent damage when subjected to high voltages. Electronics manufacturers therefore establish electrostatic protective areas free of static, using measures to prevent charging, such as avoiding highly charging materials and measures to remove static such as grounding human workers, providing antistatic devices, and controlling humidity.

http://en.wikipedia.org/wiki/Electrostatic_discharge (January 2014)

Precautions to prevent Electrostatic Discharge (ESD)

Sensitive printed circuit boards and electronic modules must always be transported and stored in protective antistatic packing bags. The circuit boards and modules must not be transported or stored close to strong electrostatic, electromagnetic or radioactive fields.

If it is necessary to open and touch the printed circuit board or module inside the protective bag, the following precautions must be taken:

- 1 The working area must be covered by an approved conductive service mat that has a resistance of between 50 k Ω and 2 M Ω , and is connected directly to a reliable earth point via its earthing cord.
- 2 You - and all other service personnel involved - must wear a wristband in direct contact with the skin. The wristband must be electrically connected to the service mat.
- 3 Printed circuit boards and electronic modules must be placed on the conductive service mat during installation and maintenance operations.
- 4 If, for any reason, it is necessary to move the circuit board from the conductive service mat, it must be placed in an approved antistatic transportation container (for example a static shielding bag) before transportation.
- 5 During installation and servicing, all electrical equipment (for example soldering irons and test equipment) must be earthed.

Preventive maintenance schedule

In order to secure long and trouble-free operation of the HiPAP 502P, certain specific preventive maintenance tasks must be done. The tasks are organized in a preventive maintenance schedule.

- After use
 - Clean the transducer
 - Clean the repeater unit
 - Lubricate the connectors
 - Check that all fasteners are tightened
 - Check that there are no physical damage to the unit
- Every month
 - Dust the units
 - APOS backup
- Every sixth month
 - Check all cable connections
 - Check all units for damage

Computer

Replacing the filter

Prerequisites

- Turn off the power to the computer.
- Make sure that the new filter is identical to the one listed in the recommended spare part list.
- Remove the computer from the damper kit
- Remove the cabinet lid from the computer.

Procedure

- 1 Press the three green handles to remove the front cover.

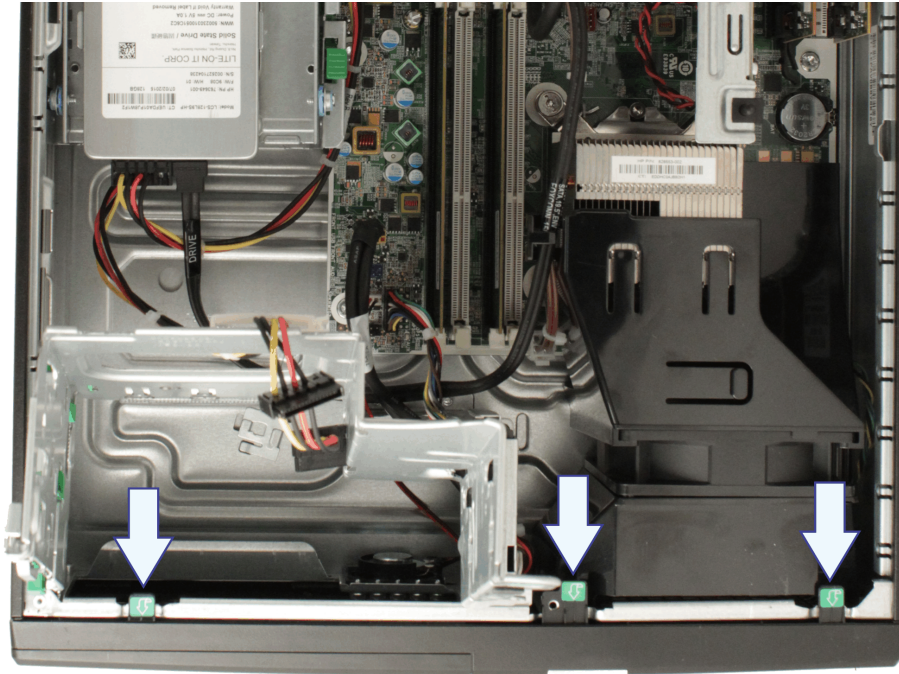

- 2 Carefully remove the old filter inside.

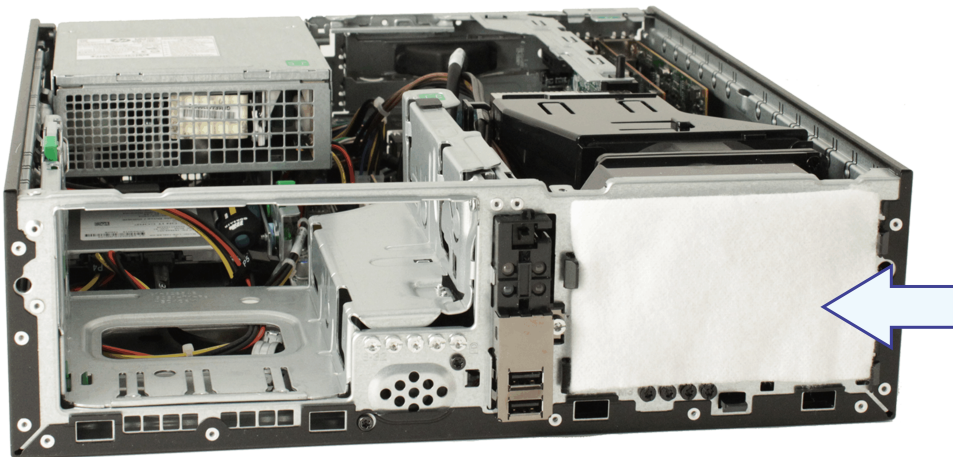

- 3 Install the new filter.
- 4 Put the front cover back in place.
- 5 Put the cabinet lid back in place.

Preventive maintenance intervals

Note

These procedures should be performed on each HiPAP in the system. Local evaluations should be made to determine site-specific maintenance intervals.

ACTION	INTERVAL RECOMMENDED
Clean all filters for units equipped with fans.	Every week.
Clean cabinet surface.	Each month.
Check for loose connectors and wires.	Every six month.

Backup

For backup procedures, refer to the Backup files document, doc no 859-216300. This is a separate manual supplied at system delivery.

You are advised to take back-up of all operator stations at regular intervals (1-3 months), and every time major changes have been performed in the configuration and /or user settings.

Important

A system backup must be performed when the software has been upgraded.

Transceiver unit

Replacing the Ethernet switch/Converter

Maintenance is not required under normal conditions apart from keeping the unit clean. If the Ethernet switch/Converter is not functioning properly, the unit must be replaced.

Procedure

- 1 Switch off the transceiver unit using the Main switch.
- 2 Remove all cables in front of the Ethernet switch.
- 3 Remove the four screws in the front.
- 4 Remove the unit and unplug the power cable.
- 5 Replace the unit.
- 6 Reconnect all cables.

7 Switch on the transceiver unit using the Main switch.

Further requirements

The new Ethernet switch/Converter must be configured. You will find the configuration information on the Operator Station.

Ref: C:\Install\moxa\moxaconfig.rtf

Removing the LPT32 Transceiver board

The circuit boards are located inside the transceiver unit.

Prerequisites

You must be equipped with a standard set of tools. This tool set must comprise the normal tools for electronic and electromechanical tasks. This includes different screwdriver types, pliers, spanners, a cable stripper, a soldering iron etc. Each tool must be provided in various sizes. We recommend that all tools are demagnetized to protect your equipment.

Context

Note

Be careful not to touch the sides of the circuit boards and filter boards as the capacitors might still be charged.

Procedure

- 1 Switch off the transceiver unit using the Main switch.
- 2 Make sure the light on the power unit inside goes from **blue to red/off** before touching the transceiver boards.
- 3 Locate the faulty board.
- 4 Note the locations and remove the cable connected to the front of the board.
- 5 Loosen the two screws (**A**).
- 6 Press down the red knobs (**B**) on the board ejectors. The ejectors are now free.
- 7 To loosen the board, push the top ejectors (**C**) up, and the bottom ejector (**C**) down.
- 8 Then pull the board out towards you (**D**).
- 9 Place the board inside an anti-static plastic bag and place it on a clean, stable work-bench where it cannot be damaged.

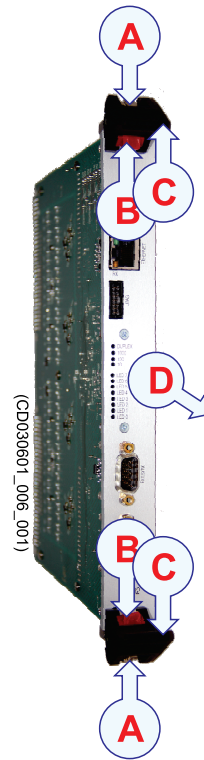

Related topics

[About Electrostatic Discharge \(ESD\), page 40](#)

Replacing a circuit board

The circuit boards are located inside the transceiver unit.

Context

Note _____

Be careful not to touch the sides of the circuit boards and filter boards as the capacitors might still be charged.

Procedure

- 1 Grab the board ejectors with both hands, and push the board in while keeping it as straight as possible.

- 2 Lock the board in place by pulling the top locking handle down, and the bottom locking handle up.
- 3 Fasten the screws.
- 4 Insert the front mounted Ethernet cable and other front mounted cables.
- 5 Once all the boards are in position, re-apply power as required.
- 6 Close the transceiver unit front door.

Related topics

[About Electrostatic Discharge \(ESD\), page 40](#)

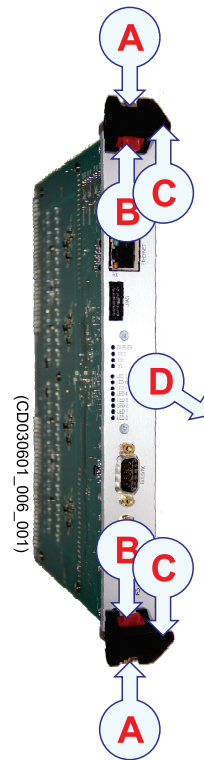

Removing a filter board

The filter boards are located inside the transceiver unit.

Context

Note

Be careful not to touch the sides of the circuit boards and filter boards as the capacitors might still be charged.

Procedure

- 1 Switch off the transceiver unit using the Main switch.
- 2 Make sure the light on the power unit inside goes from **blue to red/off** before touching the transceiver boards.
- 3 Locate the faulty board.
- 4 Note the locations and remove the cable connected to the front of the board.
- 5 Loosen the two screws.
- 6 Press down the red knobs on the board ejectors. The ejectors are now free.
- 7 To loosen the board, push the top ejectors up, and the bottom ejector down.
- 8 Then pull the filter board out towards you.

- 9 Place the board inside an anti-static plastic bag and place it on a clean, stable work-bench where it cannot be damaged.

Related topics

[About Electrostatic Discharge \(ESD\), page 40](#)

Replacing a filter board

The filter boards are located inside the transceiver unit.

Context

Note

Be careful not to touch the sides of the circuit boards and filter boards as the capacitors might still be charged.

Procedure

- 1 Grab the board ejectors with both hands, and push the board in while keeping it as straight as possible.
- 2 Lock the board in place by pulling the top locking handle down, and the bottom locking handle up.
- 3 Fasten the screws.
- 4 Insert the front mounted Ethernet cable and other front mounted cables.
- 5 Once all the boards are in position, re-apply power as required.
- 6 Close the transceiver unit front door.

Related topics

[About Electrostatic Discharge \(ESD\), page 40](#)

Removing the power module from the transceiver unit

The power module is located in back of the transceiver unit.

Prerequisites

Removing the Moxa switch makes the job of replacing the power unit easier.

Procedure

- 1 Switch off the transceiver unit using the Main switch.
- 2 Disconnect all the cables in the grey area marked in the illustration.
- 3 Disconnect the Ethernet cable from the power unit.

- 4 Remove the screw on the front of the power unit and remove the cover.
- 5 Disconnect all the cables that are connected to the power unit.
- 6 Open the lock on the right hand side of the power unit and turn it 180° counter-clockwise.
- 7 Slide the power unit to the left and pull out the power unit very carefully out of the Transceiver unit.
Pull the top of the power unit out towards you before sliding it sideways through the gap in the transceiver unit.
- 8 Make sure all cables are detached before removing the power unit.

Related topics

[About Electrostatic Discharge \(ESD\), page 40](#)

Replacing the power module in the transceiver unit

The power module is located in back of the transceiver unit.

Prerequisites

Removing the Moxa switch makes the job of replacing the power unit easier.

Procedure

- 1 Insert the new power unit through the same gap in the Transceiver unit.
- 2 Place the power unit on the six nuts on the back wall of the Transceiver unit.
- 3 Slide the power unit to the right and secure the power unit by turning the flap on the right side 180° and close the flap.
- 4 Reconnect all cable to the power unit.
- 5 Reattach the cover and secure with the screw.

Replacing the fan unit in the transceiver unit

The fan unit is located below the circuit boards inside the transceiver unit.

Prerequisites

Removing some of the circuit boards at the left side makes the job of replacing the fan unit easier.

Procedure

- 1 Switch off the transceiver unit using the Main switch.
- 2 Remove the four screws in the front.

- 3 Unplug the power cable by pressing the IEC lock on the connector at the back of the fan unit.
- 4 Remove the fan unit.
- 5 Replace the old fan unit with the new one.
- 6 Plug the power cable back in at the back of the fan unit.
- 7 Screw in the four screws in the front.
- 8 Switch on the transceiver unit using the Main switch.

Replacing the terminal block in the transceiver unit

The Ethernet switch/Converter is located below the PCB rack in the transceiver unit.

Procedure

- 1 Switch off the transceiver unit using the Main switch.
- 2 Remove the power cables in to the cabinet.
- 3 Disconnect the terminal block module.
- 4 The module is snapped on. To remove it, pull down the lock-tab in the lower end, and pull it directly out from the support rail.
- 5 Align the new module on the support rail.
- 6 Press the module and pull down the lock-tab until it snaps into place.

Replacing a fuse in the transceiver unit

The transceiver unit is powered via a Main switch mounted on the support rail at the bottom of the transceiver unit.

Context

The fuse is a circuit breaker, and it trips at 25 A.

Note

Always use the correct size and type of fuse. Irreparable damage may be caused to the transceiver unit if the wrong fuse (or anything else) is used.

Procedure

- 1 Switch off all external units and systems connected to the HiPAP system.
- 2 Remove the transceiver unit front door.
- 3 Switch off power to the unit using the Main switch.
- 4 Replace the blown fuse(s) with a fuse with correct size and type.

- 5 If the Main switch has tripped, reset the switch.

Note _____

Release the switch immediately. It is made so it can trip again if necessary.

- 6 Turn on the power to the HiPAP system and then to the other external units.

Note _____

If, when a fuse is replaced, it blows or trips again when power is switched on to the system, a more serious fault exists. Do not replace the fuse(s) a second time until the fault has been found and corrected.

- 7 Close the transceiver unit front door.

Spare parts

Topics

[Computer, page 53](#)

[HiPAP 500 transducer, page 53](#)

[Transceiver unit, page 53](#)

[LPT32 Transceiver board Spare part, page 54](#)

[LPT32 Filter board Spare part, page 54](#)

[Power supply Spare part, page 54](#)

[Ethernet switch Spare part, page 54](#)

[Fan unit Spare part, page 54](#)

Computer

Computer

- **Part name:** MP5810
- **Part number:** 413084

HiPAP 500 transducer



- **Part name:** Transducer HiPAP 500
- **Part number:** TDH-089996

The transducer comes with:

- 3 O-rings 180x4 mm
- 2 O-rings 99.1x5.7 mm
- 4 M8x20 bolts
- 12 M8x35 bolts
- 12 M8 lock washers

Transceiver unit

- **Part name:** Transceiver unit x82–M8P
- **Part number:** 435243



LPT32 Transceiver board Spare part

- **Part name:** LPT32 Transceiver board
Part number: 367861

LPT32 Filter board Spare part

- **Part name:** LPT32 Filter board
Part number: 394739

Power supply Spare part

- **Part name:** Power supply transceiver
Part number: 427030

Ethernet switch Spare part

- **Part name:** Ethernet switch transceiver
Part number: 391184

Fan unit Spare part

- **Part name:** Fan unit transceiver
Part number: 397740

Drawing file

Topics

[MP5810 Computer, page 56](#)

[Transceiver unit - Outline dimensions, page 57](#)

[435248 Transceiver unit - Wiring diagram, page 58](#)

[433851 Transducer dimensions, page 59](#)

[433953 Sensor reference point, page 60](#)

[Responder driver unit, outline dimensions, page 61](#)

[Responder driver unit, wiring diagram, page 62](#)

[Fibre to responder drive converter, wiring diagram, page 63](#)

MP5810 Computer

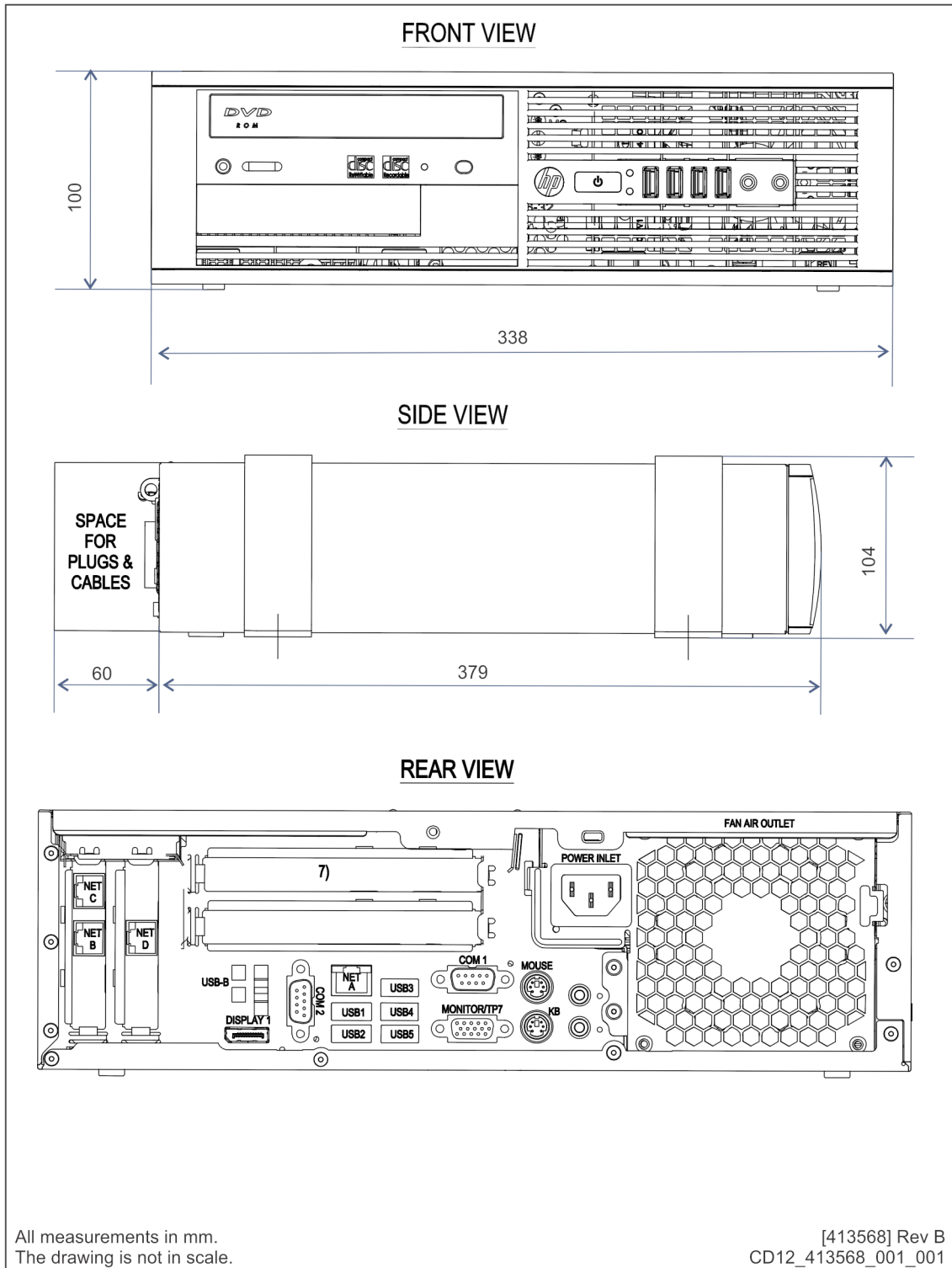

Transceiver unit - Outline dimensions

Drawing 400538.

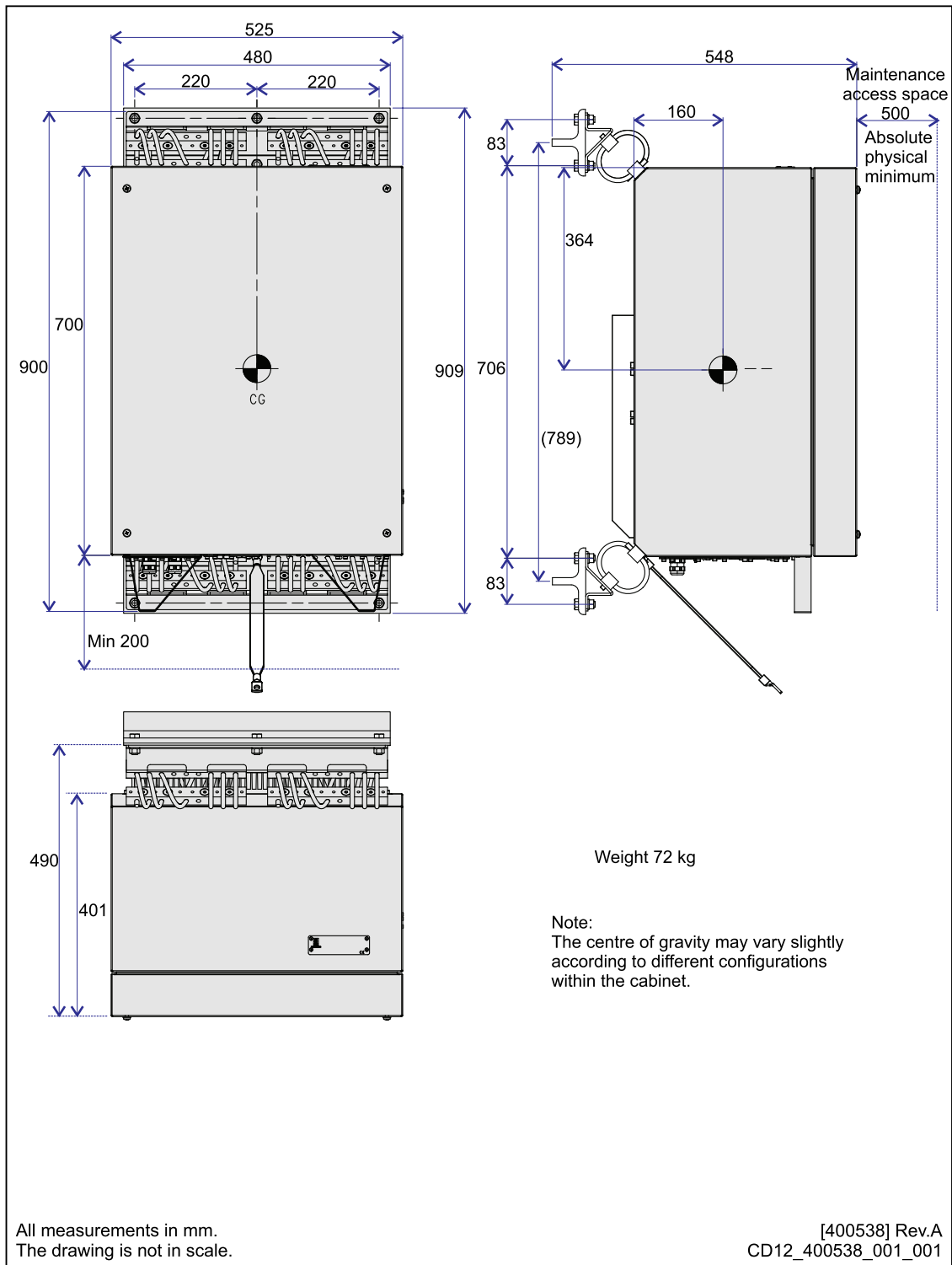

435248 Transceiver unit - Wiring diagram

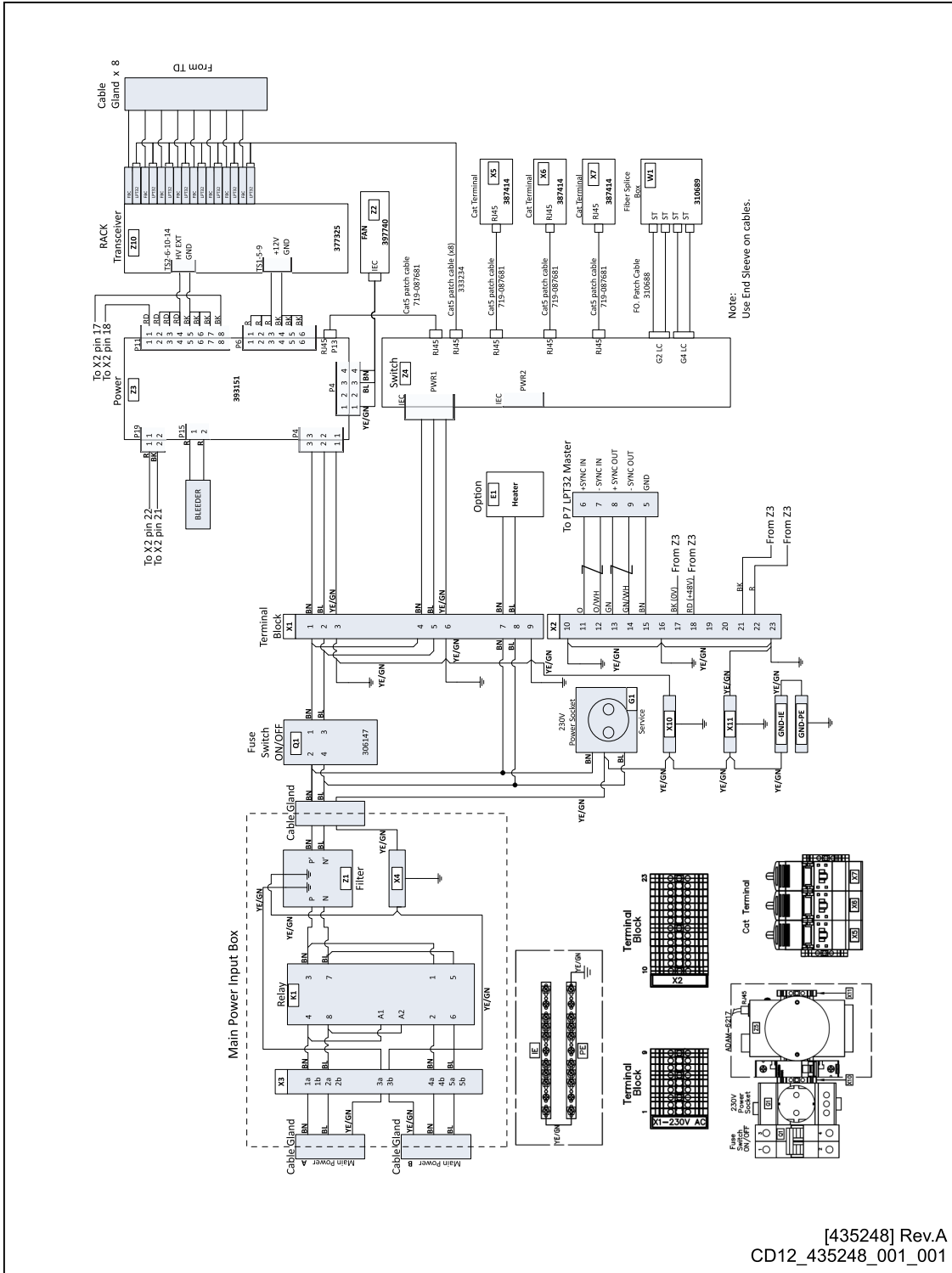

[435248] Rev.A
CD12_435248_001_001

433851 Transducer dimensions

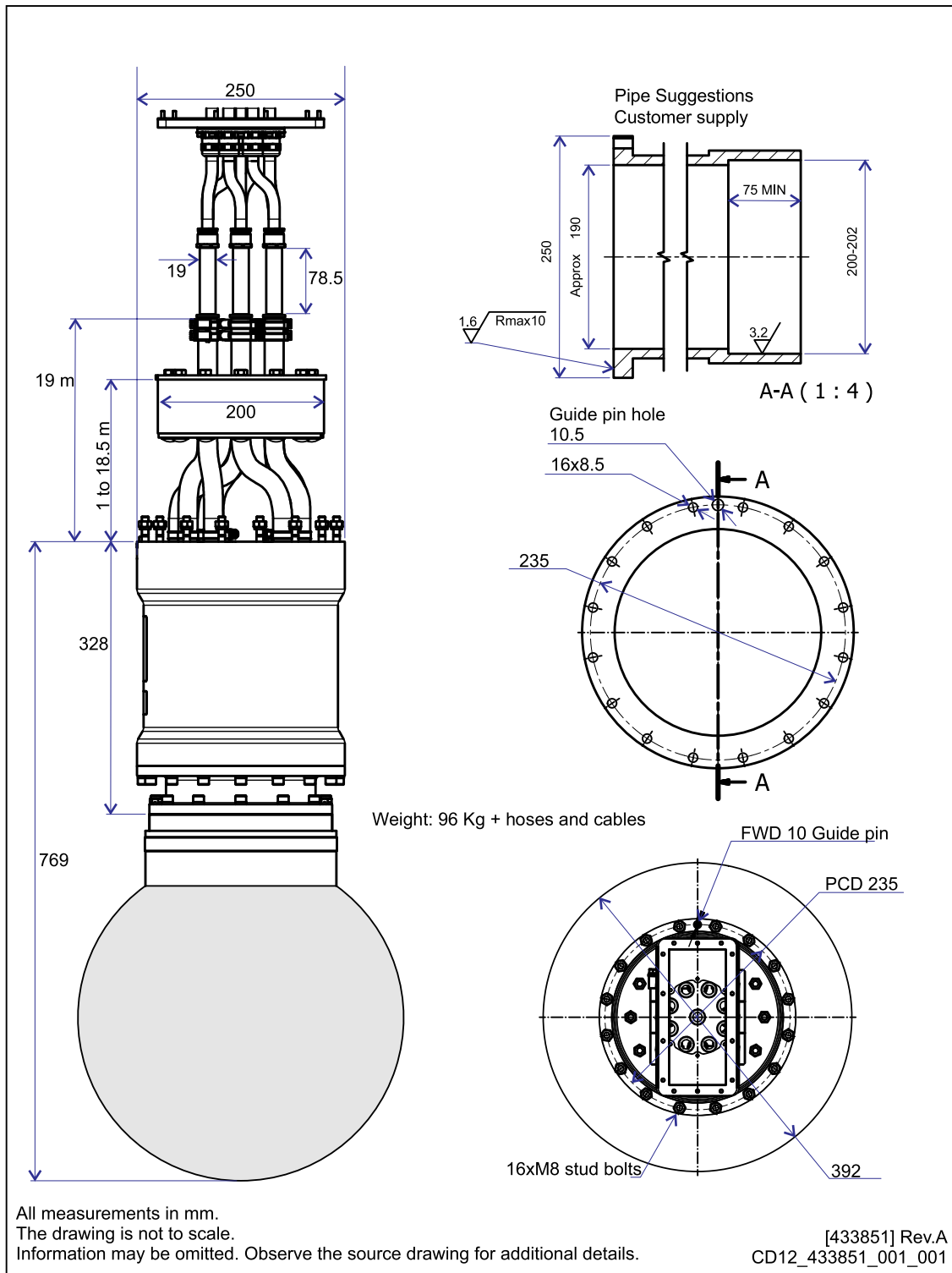

433953 Sensor reference point

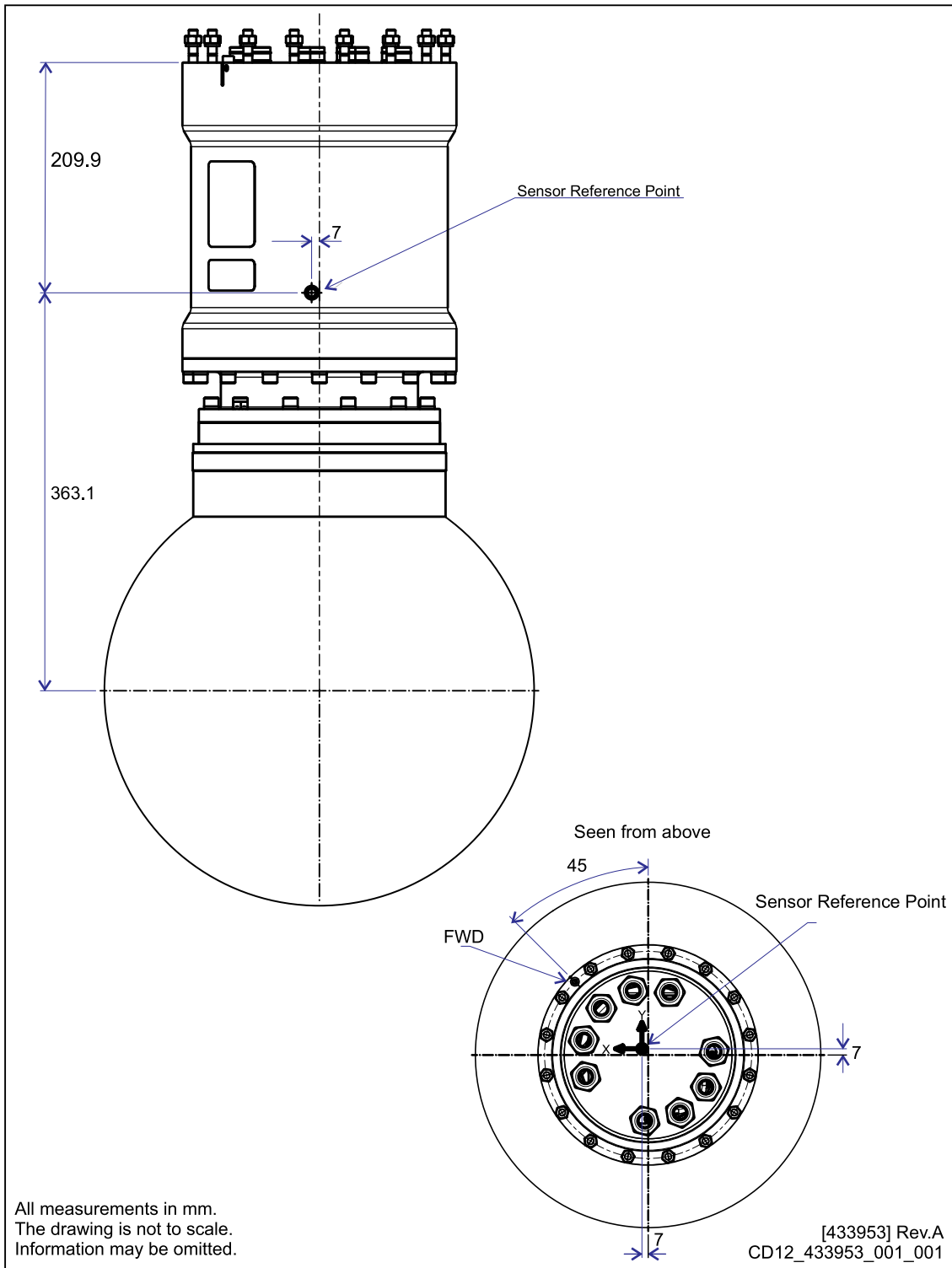

Responder driver unit, outline dimensions

Drawing 316067

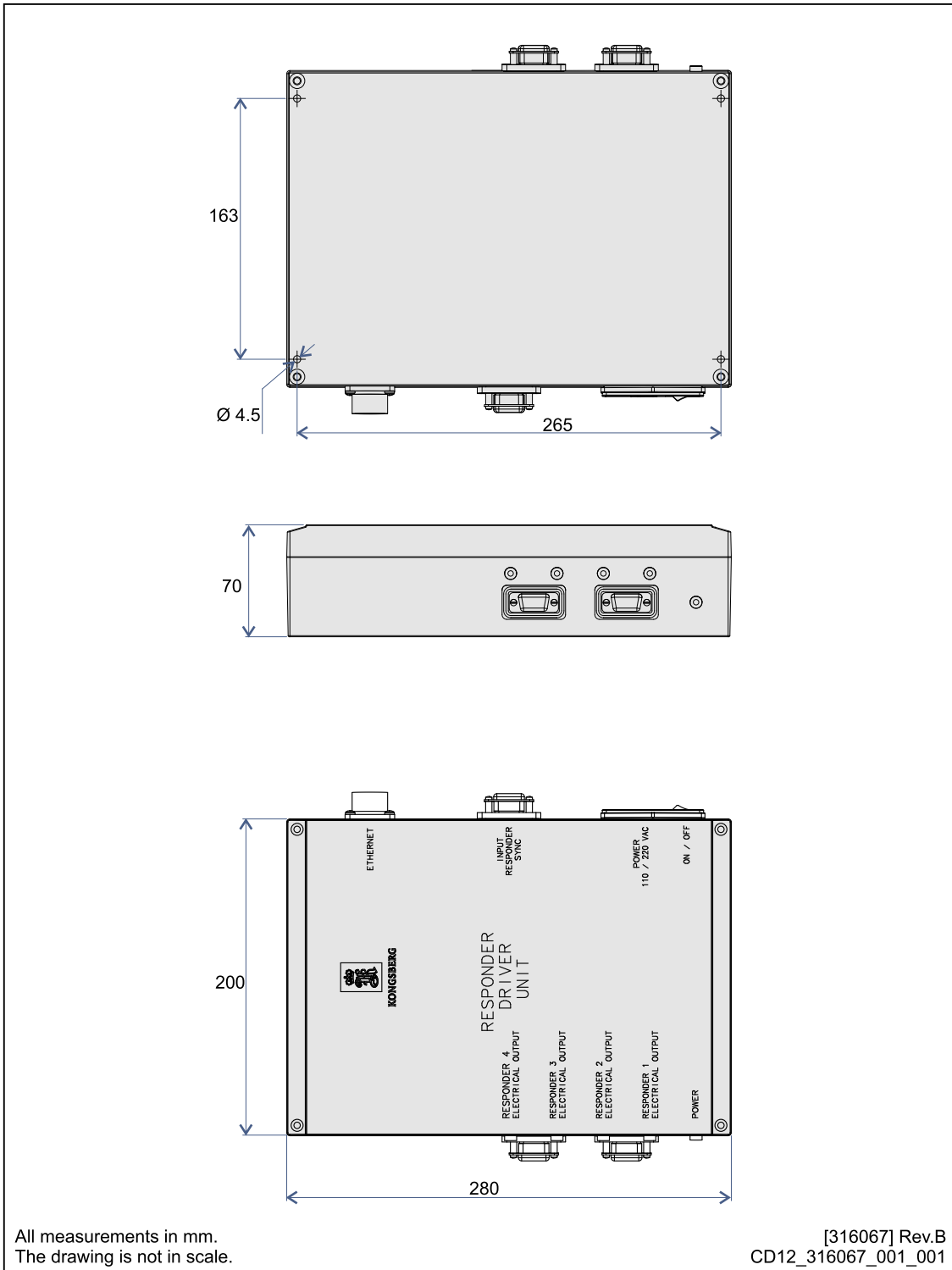

Responder driver unit, wiring diagram

Drawing 313697

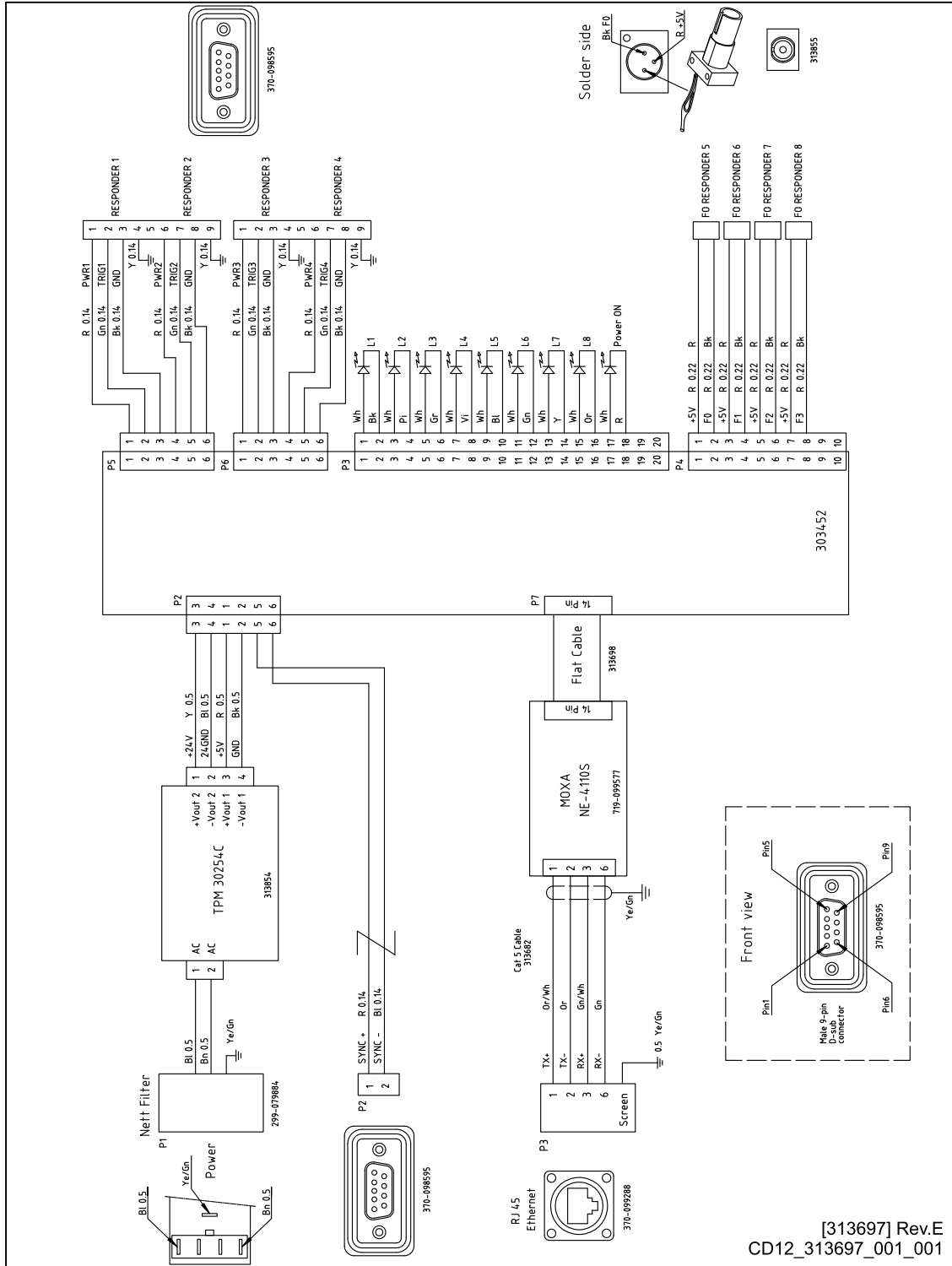

[313697] Rev.E
CD12_313697_001_001

Fibre to responder drive converter, wiring diagram

Drawing 308850

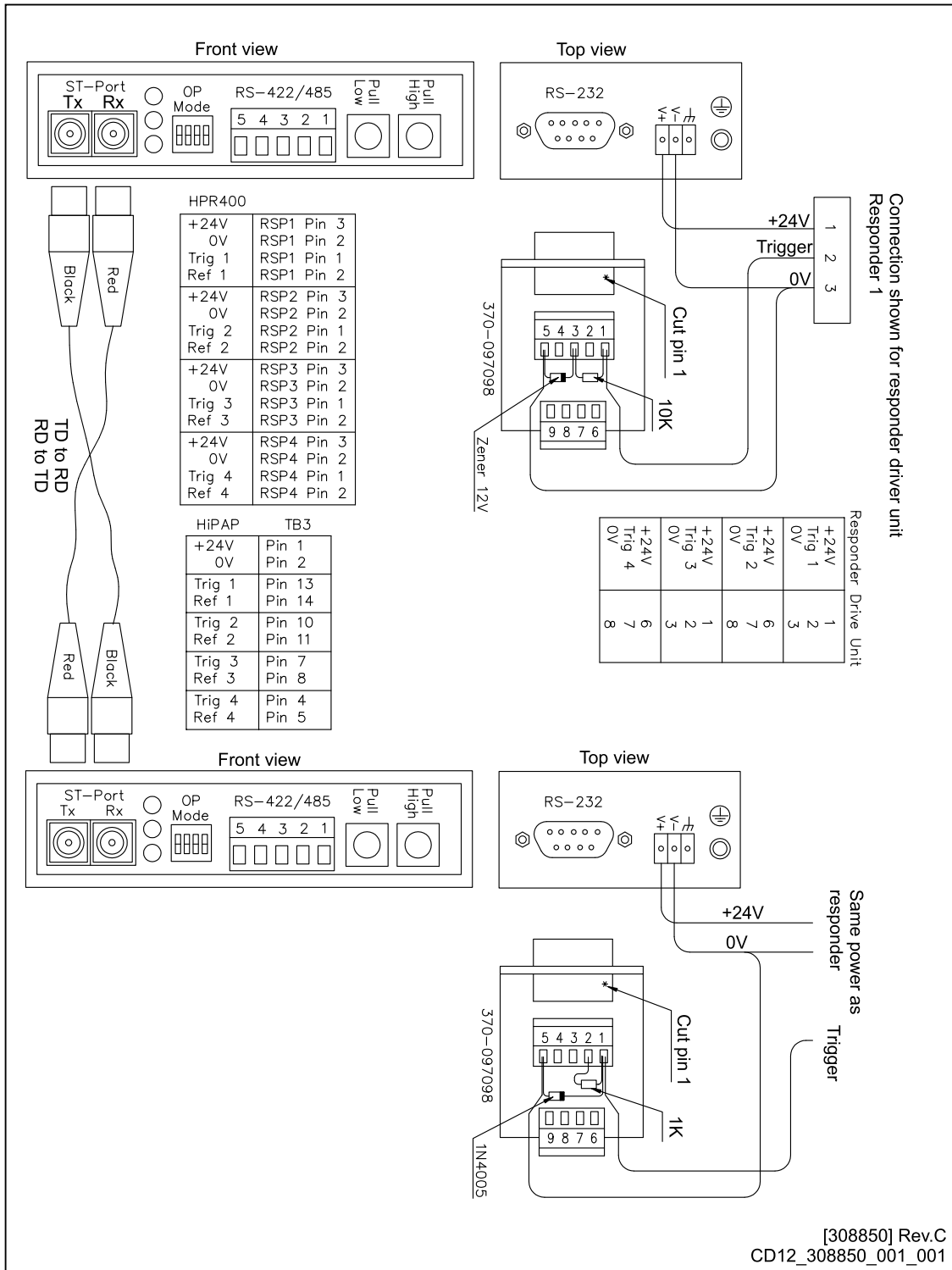

Equipment handling

Topics

[Inspection of units and transportation boxes after arrival, page 65](#)

[Unpacking standard parts and units, page 65](#)

[Specifications for storage after unpacking, page 67](#)

[Transporting Kongsberg Maritime equipment, page 68](#)

Inspection of units and transportation boxes after arrival

A visual inspection must be done immediately after the box(es) have arrived at their destination.

Prerequisites

If you suspect that the equipment has been damaged during the transport, request that a representative of the carrier is present during the inspection.

Procedure

- 1 Check all boxes (wooden or cardboard boxes, plastic bags and/or pallets) for physical damage.
Look for signs of dropping, immersion in water or other mishandling.
- 2 If external damage is detected, open the box to check its contents.
Request that a representative of the carrier to be present while the box is opened, so any transportation damage can be identified and documented.
- 3 If a unit has been damaged, prepare an inspection report stating the condition of the unit and actions taken.
Describe the damage, and collect photographic evidence if possible. Return the inspection report to Kongsberg Maritime as soon as possible.
- 4 If units are not damaged, check the humidity absorbing material.
If required, dry or replace the bags, then re-pack the unit(s) according to the packing instructions.

Unpacking standard parts and units

Prior to installation or use, parts and units must be inspected, and then unpacked from their transport boxes. It is important that this unpacking is done without inflicting damage to the equipment.

Context

This procedure provides the basic tasks of unpacking units (main unit, spare parts etc) from boxes shipped from Kongsberg Maritime.

Note

If the unit in question is not unpacked for immediate use, you may consider storing it unopened in its original box. However, it may be useful to open the box to check its contents for damage and retrieve any accompanying documentation.

Do not use a knife to open cardboard boxes - the contents may be located close to the surface, and can then be damaged by the blade.

Procedure

- 1 Check the carton before opening it to ensure it shows no signs of dropping, immersion in water or other mishandling.
 - 1 If external damage is detected, open the box to check its contents.
 - 2 Request that a representative of the carrier to be present while the box is opened, so any transportation damage can be identified and documented.
 - 3 If a unit has been damaged, prepare an inspection report stating the condition of the unit and actions taken.

Describe the damage, and collect photographic evidence if possible. Return the inspection report to Kongsberg Maritime as soon as possible.
- 2 Place the box on a stable work bench or on the floor with the top of the box facing upwards.
- 3 In the absence of other instructions, always open the top of the carton first.

The contents of the box will normally have been lowered into the carton from above, so this will usually be the easiest route to follow. Be careful when you open the box, and make sure that the contents are not damaged. Do not use a knife to open cardboard boxes.
- 4 If the box has been closed using staples, remove the staples from the carton as you open it.

This will reduce the possibilities of scratch injury to yourself and damage to the contents.
- 5 If a wooden box has been closed using screws, always remove them using a screwdriver.

Do not attempt to force the lid open with a crowbar or similar tool.
- 6 Once the carton is open, carefully remove all loose packing and insulation material.
- 7 Check for user manuals and other documents that may have been added to the carton during packing.
- 8 Check also for special tools, door keys etc.

Specifications for storage after unpacking

The unit must whenever possible be stored in its original transportation crate until ready for installation.

General specifications

During storage, each box must not be used for any purpose for which it was not intended (work platform, table, steps etc.).

Once unpacked, all equipment must be kept in a dry, non condensing atmosphere, free from corrosive agents and isolated from sources of vibration.

Note

Do not break the seal to open a circuit board package before the board is to be used. If the board package is returned to Kongsberg Maritime with the seal broken, we will assumed that the unit has been used, and then you will be billed accordingly.

Each unit must be installed in its intended operating position as soon as possible after unpacking. If the unit contains normal batteries, these may have been disconnected/isolated before the unit was packed. These must then be reconnected during the installation procedure. Units containing batteries are marked.

Caution

Units containing lithium or alkaline batteries must be handled separately and with care. Such units are marked accordingly. Do not attempt to recharge such batteries, open them, or dispose of them by incineration.

Refer to the applicable product data sheets or battery handling procedures for further details.

Temperature protection

Any units that requires protection against extreme temperatures are identified as such in the applicable documentation. The box used to transport and store such units are clearly marked, for example:

Must not be transported or stored in temperatures below -5 °C.

Other temperature limits may be used if applicable.

If a unit needs temperature protection, the box to be used for storage and transportation must be lined on all walls, base and lid, using minimum 5 cm thick polyurethane or polystyrene foam.

Most system units can normally be stored in temperatures between -30° C and +70° C. Refer to the relevant technical specifications for details.

Note

Unless otherwise specified, transducers and hydrophones must not be stored in temperatures below -10°C and above $+50^{\circ}\text{C}$.

Transporting Kongsberg Maritime equipment

Unless otherwise stated in the accompanying documentation, electronic, electromechanical and mechanical units supplied by Kongsberg Maritime can be only transported using methods approved for delicate and fragile equipment.

Prerequisites

Transportation methods approved for delicate equipment includes transportation by road, rail, air or sea.

Context

The units are to be transported in accordance with general or specific instructions for the appropriate unit(s), using pallets, transport cases, wooden boxes, or carton boxes as appropriate.

Observe the packing instructions.

Note

Special local restrictions concerning air transportation may be applied to units containing certain types of batteries. These units must be checked properly, and the regulations must be investigated by the packer/shipper before the unit is dispatched.

Procedure

- 1 Ensure that all local transportation is done according to the same specifications as for the initial delivery.
- 2 Make sure that the box containing the unit is kept dry at all times, and sheltered from the weather.

It must not be subjected to shocks, excessive vibration or other rough handling. The box will normally be marked with text or symbols indicating which way it is to be placed. Follow the instructions provided, and make sure that the box is always placed with its “top” facing upwards.

- 3 Make sure that the box is not used for any purpose for which it was not intended (step, table, etc.).

In the absence of other information, no other boxes must be stacked on top of it.

- 4 Handle all boxes and units with care.

Note

Due to the nature of Kongsberg Maritime's products, and the extensive use of delicate electronic parts, all units and boxes must be regarded and handled as fragile equipment.

Index

367861		outline dimensions.....	36
LPT32 spare part.....	54	outline dimensions drawing.....	56
391184		power requirements.....	37
switch spare part.....	54	spare part.....	53
394739		weight.....	36
LPT32 filter board spare part.....	54	connecting AC mains	
397740		to the transceiver.....	26
fan spare part.....	54	connecting ground	
413084		to the transceiver.....	26
computer.....	53	connecting transducer	
427030		to the transceiver.....	28
power supply spare part.....	54	connection	
435243		diagram.....	21
transceiver spare part.....	53	serial cable used for synchronization.....	29
A		connectors	
about		computer.....	25
document downloads.....	7	D	
electrostatic discharge (ESD).....	40	description	
online information.....	7	operator station.....	11
purpose of this manual.....	7	system.....	9
registered trademarks.....	7	Transceiver Unit.....	11
target audience.....	7	diagram	
transducer.....	12	connections.....	21
AC mains		wiring.....	21
connecting to the transceiver.....	26	dimensions	
APOS		computer.....	36
backup.....	44	computer outline dimensions drawing.....	56
audience		display.....	36
this manual.....	7	technical specifications.....	36
B		transceiver.....	36
backup		transducer.....	37
APOS.....	44	dimensions drawing	
block		transducer.....	59
diagram.....	10	display	
book		outline dimensions.....	36
purpose.....	7	weight.....	36
target audience.....	7	documents	
C		download from website.....	7
cable drawing		download	
serial line used for synchronization.....	29	documents from website.....	7
cable plan.....	21	drawing	
cables		computer outline dimensions.....	56
list of system interconnection cables.....	22	serial line cable used for synchronization.....	29
cabling		system diagram.....	10
RDU.....	31	transducer outline dimensions.....	59
characteristics		E	
performance.....	35	electrical to fibre optical converter	
computer		installation.....	32
413084.....	53	electrostatic discharge (ESD)	
connectors.....	25	about.....	40
environmental requirements.....	38	preventing.....	41
filter.....	42	what is it?.....	40
installation.....	16	environmental	
maintenance.....	44	requirements.....	38
		environmental requirements	
		computer.....	38

transceiver	38	inspection	
Transceiver Unit	38	transportation boxes	65
equipment		units	65
handling	13	installation	
receipt	13	computer	16
responsibility	13	converter	32
storage	13	RDU	18
equipment handling	64	transceiver	18
inspection	65	installation requirements	
storage after unpacking	67	environmental	38
transportation	68	humidity	38
unpacking	65	temperature	38
visual inspection	65	interconnection cables	
ESD (electrostatic discharge)		list	22
about	40	interfaces	
preventing	41	computer	25
what is it?	40	introduction	
ethernet switch		operator station	11
spare part	54	Transceiver Unit	11
F		K	
fan unit		kits	
spare part	54	transducer	53
fibre converter		Kongsberg Maritime	
wiring diagram	63	support	13
fibre optical to electrical converter		L	
installation	32	LCD monitor	
functional		outline dimensions	36
diagram	10	weight	36
G		list	
general supply conditions	12	system interconnection cables	22
equipment responsibility	13	LPT32	
receipt	13	maintenance	46–48
storage	13	removing a filter board	47
unpacking	13	replacing a circuit board	46
ground		replacing a filter board	48
connecting to the transceiver	26	LPT32 filter board	
H		spare part	54
how to		LPT32 transceiver board	
cable RDU to responder	31	spare part	54
connect AC mains to the transceiver	26	LPT32 Transceiver board	
connect ground to the transceiver	26	removing	45
connect transducer to the transceiver	28	M	
install the computer	16	maintenance	
install the RDU	18	computer	44
install the transceiver	18	LPT32	46–48
remove the LPT32 Transceiver board	45	MP5810	44
transport Kongsberg Maritime equipment	68	preventive, schedule	42
unpack standard parts and units	65	removing a filter board	47
visual inspection of units and transportation		removing the power module from the	
boxes after arrival	65	transceiver unit	48
humidity		replacing a circuit board	46
requirements	38	replacing a filter board	48
I		replacing a fuse in the transceiver unit	50
information		replacing the Ethernet switch/Converter	44
online	7	replacing the fan unit in the transceiver unit	49
support	13	replacing the power module in the transceiver	
		unit	49

replacing the terminal block in the transceiver unit	50	physical dimensions	
manual		responder driver unit	61
purpose	7	transceiver unit	57
target audience	7	plan	
monitor		cable	21
outline dimensions	36	plugs	
weight	36	computer	25
MP5810		power	
filter	42	requirements	37
maintenance	44	specifications	37
O		power consumption	
offices		computer	37
support	13	transceiver	37
online		Transceiver Unit	37
information	7	power requirements	
operating procedures		computer	37
see APOS online help	33	transceiver	37
operating voltage		Transceiver Unit	37
computer	37	power supply	
transceiver	37	part number	54
Transceiver Unit	37	spare part	54
operator station		precautions	
description	11	electrostatic discharge (ESD)	41
introduction	11	preventing	
overview	11	electrostatic discharge (ESD)	41
purpose	11	preventive maintenance	
order number		schedule	42
computer	53	procedure	
ethernet switch	54	cable from RDU to responder	31
fan unit	54	connecting AC mains to the transceiver	26
filter board	54	connecting ground to the transceiver	26
transceiver	53	connecting transducer to the transceiver	28
transceiver board	54	installing the computer	16
outline dimensions		installing the RDU	18
computer	36	installing the transceiver	18
display	36	removing the LPT32 Transceiver board	45
responder driver unit	61	transporting Kongsberg Maritime equipment	68
technical specifications	36	unpacking standard parts and units	65
transceiver	36	visual inspection of units and transportation	
transceiver unit	57	boxes after arrival	65
transducer	37	publication	
outline dimensions drawing		purpose	7
computer	56	target audience	7
transducer	59	purpose	
overview		operator station	11
operator station	11	this manual	7
Transceiver Unit	11	Transceiver Unit	11
P		R	
part number		RDU	
computer	53	cabling	31
ethernet switch	54	installation	18
fan unit	54	reader	
filter board	54	this manual	7
power supply	54	receipt	
transceiver	53	general supply conditions	13
transceiver board	54	registered trademarks	7
PC		removing	
installation	16	LPT32 Transceiver board	45
performance		removing a filter board	
specifications	35	LPT32	47
		maintenance	47
		removing the power module	
		transceiver unit x82	48

removing the power module from the transceiver unit	
maintenance	48
replacing a circuit board	
LPT32	46
maintenance	46
replacing a filter board	
LPT32	48
maintenance	48
replacing a fuse	
transceiver unit	50
replacing a fuse in the transceiver unit	
maintenance	50
replacing the Ethernet switch/Converter	
maintenance	44
replacing the fan unit	
transceiver unit x82	49
replacing the fan unit in the transceiver unit	
maintenance	49
replacing the filter	42
replacing the power module	
transceiver unit x82	49
replacing the power module in the transceiver unit	
maintenance	49
replacing the terminal block	
transceiver unit x82	50
replacing the terminal block in the transceiver unit	
maintenance	50
requirements	
environmental	38
humidity	38
power	37
temperature	38
responder driver unit	
outline dimensions	61
wiring diagram	62
responsibility	
equipment	13
RS-422	
serial line cable used for synchronization	29
S	
schedule	
preventive maintenance	42
serial line	
used for synchronization	29
size	
computer	36
display	36
responder driver unit	61
technical specifications	36
transceiver	36
transceiver unit	57
sockets	
computer	25
spare part	52
computer	53
ethernet switch	54
fan unit	54
LPT32 filter board	54
LPT32 transceiver board	54
power supply	54
transceiver	53
spare part fan	
397740	54
spare part LPT32	
367861	54
spare part LPT32 filter board	
394739	54
spare part power supply	
427030	54
spare part switch	
391184	54
spare parts	
transducer	53
specifications	
outline dimensions	36
performance	35
power	37
serial line cable used for synchronization	29
storage after unpacking	67
storage	
after unpacking	67
general supply conditions	13
supply conditions	12
equipment responsibility	13
receipt	13
storage	13
unpacking	13
supply voltage	
computer	37
transceiver	37
Transceiver Unit	37
support information	13
synchronization	
cables using RS-422 serial line	29
system	
description	9
diagram	10
system cables	
list	22
T	
target audience	
this manual	7
technical specifications	
outline dimensions	36
temperature	
requirements	38
this manual	
purpose	7
target audience	7
trademarks	
registered	7
transceiver	
435243	53
connecting AC mains	26
connecting ground	26
connecting transducer	28
environmental requirements	38
installation	18
outline dimensions	36
power requirements	37
spare part	53
weight	36
transceiver unit	
outline dimensions	57
replacing a fuse	50

Transceiver Unit

- description 11
- environmental requirements 38
- introduction 11
- overview 11
- power requirements 37
- purpose 11
- transceiver unit x82
 - removing the power module 48
 - replacing the fan unit 49
 - replacing the power module 49
 - replacing the terminal block 50
- transducer
 - about 12
 - connecting to the transceiver 28
 - dimensions 37
 - outline dimensions drawing 59
 - spare parts 53
 - weight 37
- transportation
 - of delicate and fragile equipment 68

U

unpacking

- general supply conditions 13
- standard parts and units 65

V

visual inspection

- transportation boxes 65
- units 65

W

website

- download documents 7

weight

- computer 36
- display 36
- transceiver 36
- transducer 37

what is

- electrostatic discharge (ESD) 40

wiring

- diagram 21
- list of system interconnection cables 22

wiring diagram

- fibre converter for responder driver unit 63
- responder driver unit 62

©2018 Kongsberg Maritime