



KONGSBERG

cNODE Embed Instruction Manual

429468/B

October 2020 © Kongsberg Maritime AS

Document information

- **Product:** Kongsberg cNODE Embed
- **Document:** Instruction Manual
- **Document part number:** 429468
- **Revision:** B
- **Date of issue:** 30 October 2020

Copyright

The information contained in this document remains the sole property of Kongsberg Maritime AS. No part of this document may be copied or reproduced in any form or by any means, and the information contained within it is not to be communicated to a third party, without the prior written consent of Kongsberg Maritime AS.

Warning

The equipment to which this manual applies must only be used for the purpose for which it was designed. Improper use or maintenance may cause damage to the equipment and/or injury to personnel. You must be familiar with the contents of the appropriate manuals before attempting to operate or work on the equipment.

Kongsberg Maritime disclaims any responsibility for damage or injury caused by improper installation, use or maintenance of the equipment.

Disclaimer

Kongsberg Maritime AS endeavours to ensure that all information in this document is correct and fairly stated, but does not accept liability for any errors or omissions.

Support information

If you require maintenance or repair, contact Kongsberg Maritime's support organisation. You can also contact us using the following address: km.support.hpr@kongsberg.com. If you need information about our other products, visit <https://www.kongsberg.com/maritime>.

Table of contents

ABOUT THIS MANUAL	5
KONGSBERG CNODE EMBED	6
System description.....	7
Scope of supply.....	7
General supply conditions.....	7
Receipt, unpacking and storage.....	7
Support information.....	8
INSTALLING THE CNODE EMBED CABLES	9
About Electrostatic Discharge (ESD).....	10
Installing the cNODE Embed cables.....	11
Installing the transducer cables TD180.....	12
Installing the transducer cables TD80V.....	13
Connectors.....	15
Transducer connector pinout J1.....	15
Power connector J4.....	16
Service connector J5.....	17
GENERAL ACOUSTIC CONSIDERATIONS	18
OPERATING PROCEDURES	20
SPARE PARTS	21
TD180 Spare part.....	22
TD80V Spare part.....	22
Printed Circuit Board (PCB) Spare part.....	22
Capacitor Spare part.....	22
Transformer TD180 Spare part.....	22
Transformer TD80V Spare part.....	23
Cable kit Spare part.....	23
TECHNICAL SPECIFICATIONS	24
Performance specifications.....	25
Weight and outline dimensions.....	26
Power requirements.....	27
Environmental requirements.....	27
DRAWING FILE	28
TD80V Outline dimensions.....	29
TD180 Outline dimensions.....	30
PCB Outline dimensions.....	31
cNODE Embed TD80V Low wiring diagram.....	32

cNODE Embed TD180 wiring diagram33

About this manual

The purpose of this manual is to provide the descriptions, procedures and detailed parameter explanations required to allow for safe and efficient use of the cNODE Embed.

Target audience

This manual is intended for all users of the cNODE Embed.

Online information

All end-user manuals provided for operation and installation of your cNODE Embed can be downloaded from our website.

<https://www.kongsberg.com/maritime>

Registered trademarks

Observe the registered trademarks that apply.

Windows® is a registered trademark of Microsoft Corporation in the United States and other countries.

HiPAP® is a registered trademark of Kongsberg Maritime AS in Norway and other countries.

cNODE® is a registered trademark of Kongsberg Maritime AS in Norway and other countries.

Kongsberg cNODE Embed

Topics

[System description, page 7](#)

[Scope of supply, page 7](#)

[General supply conditions, page 7](#)

[Support information, page 8](#)

System description

cNODE Embed is designed for integration onto AUVs, ROVs or other vehicles where space and weight are restricted.

The cNODE Embed provides flexibility to integrate transponder electronics into a custom pressure housing. This reduces the size, weight and the need for subsea interface cabling.

A variety of flush mount and remote transducers are available to provide optimal performance in shallow, deep water or horizontal positioning applications for AUVs, ROVs, gliders, towed fish or nodes.

It has the same SSBL, LBL and telemetry capability as a standard cNODE and provides the same performance when positioning the transponder with any HiPAP SSBL or cPAP LBL system.

It operates in the Medium Frequency 20 kHz to 30 kHz band and both FSK and Kongsberg Cymbal navigation codes are available. Cymbal wide band offers 560 unique navigation codes and range accuracies of better than 2 cm are achievable.

Scope of supply

The main units required are provided with the standard delivery.

- Printed Circuit Board (PCB)
- Transducer
- Transformer
- Cable kit (Optional)
- Quick Reference Guide

General supply conditions

General supply conditions apply to this cNODE Embed delivery.

Receipt, unpacking and storage

Upon accepting shipment of the equipment, the shipyard and/or the dealer must ensure that the delivery is complete and inspect each shipping container for evidence of physical damage.

If the inspection reveals any indication of crushing, dropping, immersion in water or any other form of damage, the recipient should request that a representative from the company used to transport the equipment be present during unpacking.

All equipment must be inspected for physical damage, i.e. broken controls and indicators, dents, scratches etc. during unpacking. If any damage to the equipment is discovered, the recipient must notify both the transportation company and Kongsberg Maritime so that Kongsberg Maritime can arrange for replacement or repair of the damaged equipment.

Once unpacked, the equipment must be stored in a controlled environment with an atmosphere free of corrosive agents, excessive humidity or temperature extremes.

The equipment must be covered to protect it from dust and other forms of contamination when stored.

Support information

Should you need technical support for your cNODE Embed you must contact a Kongsberg Maritime office. A list of all our offices is provided on our website. You can also contact our main support office in Norway.

Manuals and technical information can be downloaded from our support website.

Company name	Kongsberg Maritime AS
Address	Strandpromenaden 50, 3183 Horten, Norway
Telephone	+47 33 03 41 00
Telephone 24h support	+47 33 03 24 07
Telefax	+47 33 04 76 19
Website	https://www.kongsberg.com/maritime/
Support website	Product support A to Z
E-mail address	km.support.hpr@kongsberg.com

Installing the cNODE Embed cables

Topics

[About Electrostatic Discharge \(ESD\), page 10](#)

[Installing the cNODE Embed cables, page 11](#)

[Installing the transducer cables TD180, page 12](#)

[Installing the transducer cables TD80V, page 13](#)

[Connectors, page 15](#)

About Electrostatic Discharge (ESD)

Electrostatic discharge (ESD) is the sudden flow of electricity between two electrically charged objects. Such flow can be caused by contact, an electrical short, or dielectric breakdown. Electrostatic discharge (ESD) can cause serious damage to printed circuit boards and electronic modules.

Beware of Electrostatic Discharge (ESD)!

Note

When you handle electronic circuit boards and modules, you must beware of the dangers of electrostatic discharge (ESD), both to yourself and to the equipment. In order to ensure safe transport and storage, circuit boards and other electronic units will always be wrapped in a clear plastic protective bag, and the bag will be sealed.

For correct and safe handling of printed circuit boards and electronic modules, you need a suitable working area. The working area must be covered by an approved conductive service mat that has a resistance of between 50 k Ω and 2 M Ω , and is connected directly to a reliable earth point via its earthing cord. You - and all other service personnel involved - must wear a wristband in direct contact with the skin. The wristband must be electrically connected to the service mat..

What is Electrostatic Discharge (ESD)?

Electrostatic Discharge (ESD) is the transfer of an electrostatic charge between two bodies at different electrostatic levels, caused either by direct contact or induction by an electrostatic field. The passing of a charge through an electronic device can cause local overheating, and it can also "puncture" insulating layers within the structure of the device. This may deposit a conductive residue of the vaporized metal on the device, and thus create a short circuit. Electrostatic Discharge (ESD) may result in a failures or degraded performance of the device.

ESD can create spectacular electric sparks (thunder and lightning is a large-scale ESD event), but also less dramatic forms which may be neither seen nor heard, yet still be large enough to cause damage to sensitive electronic devices. Electric sparks require a field strength above approximately 4 kV/cm in air, as notably occurs in lightning strikes. Other forms of ESD include corona discharge from sharp electrodes and brush discharge from blunt electrodes.

ESD can cause a range of harmful effects of importance in industry, including gas, fuel vapour and coal dust explosions, as well as failure of solid state electronics components such as integrated circuits. These can suffer permanent damage when subjected to high voltages. Electronics manufacturers therefore establish electrostatic protective areas free of static, using measures to prevent charging, such as avoiding highly charging materials and measures to remove static such as grounding human workers, providing antistatic devices, and controlling humidity.

http://en.wikipedia.org/wiki/Electrostatic_discharge (January 2014)

Precautions to prevent Electrostatic Discharge (ESD)

Sensitive printed circuit boards and electronic modules must always be transported and stored in protective antistatic packing bags. It is also important that they are not transported or stored close to strong electrostatic, electromagnetic or radioactive fields. If it is necessary to open and touch the printed circuit board or module inside the protective bag, the following precautions must be taken.

- 1 For correct and safe handling of printed circuit boards and electronic modules, you need a suitable working area. The working area must be covered by an approved conductive service mat that has a resistance of between 50 k Ω and 2 M Ω , and is connected directly to a reliable earth point via its earthing cord.
- 2 You - and all other service personnel involved - must wear a wristband in direct contact with the skin. The wristband must be electrically connected to the service mat.
- 3 Printed circuit boards and electronic modules must be placed on the conductive service mat during installation and maintenance operations.
- 4 If, for any reason, it is necessary to move the circuit board from the conductive service mat, it must be placed in an approved antistatic transportation container (for example a static shielding bag) before transportation.
- 5 During installation and servicing, all electrical equipment (for example soldering irons and test equipment) must be earthed.

Installing the cNODE Embed cables

The cables can be provided with an optional cable kit.

Prerequisites

The following specific items are required for this task.

- 1 x Molex 4-pin receptacle 43025-0400
- 1 x Molex 8-pin receptacle 43025-0800
- 1 x Molex 10-pin receptacle 43025-1000
- 14 x Molex Female crimp terminal 43030-0008

If you have a cable kit, the wires are already connected to the connectors.

Procedure

- 1 Connect the transducer cable.
 - [Installing the transducer cables TD80V, page 13](#)
 - [Installing the transducer cables TD180, page 12](#)
 - [Transducer connector pinout J1, page 15](#)

- 2 Prepare 2 red and 2 black wires with the appropriate length for the power.
- 3 Add crimp terminals to the end of the wires.
- 4 Install the crimp terminals in a Molex 4-pin receptacle according to the cable drawing.

[Power connector J4, page 16](#)

This is now connector J4.

- 5 Connect J4 to P4 in the front on the PCB.
- 6 Prepare 3 wires with the appropriate length for the service interface.
- 7 Add crimp terminals to the end of the wires.
- 8 Install the crimp terminals in a Molex 10-pin receptacle according to the cable drawing.

[Service connector J5, page 17](#)

This is now connector J5.

- 9 Connect J5 to P5 in the front on the PCB.

Installing the transducer cables TD180

The cables can be provided with an optional cable kit.

Prerequisites

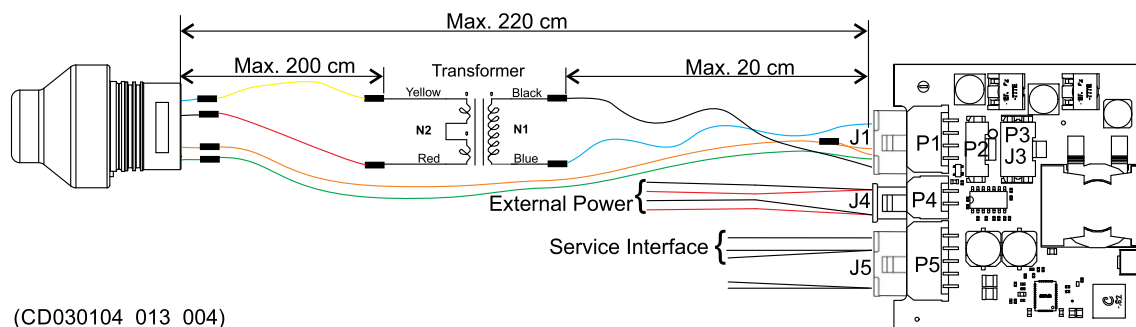

[Transducer connector pinout J1, page 15](#)

The following specific items are required for this task.

- 1 x Molex 8-pin receptacle 43025-0800
- 7 x Molex Female crimp terminal 43030-0008

Procedure

- 1 Use one yellow wire (0.5 mm²) and connect the white wire from the transducer with the yellow wire from the transformer.

- 2 Use one red wire (0.5 mm²) and connect the black wire from the transducer with the red wire from the transformer.
- 3 Use two black wires (0.5 mm²) and connect both to the black wire from the transformer.
- 4 Use two blue wires (0.5 mm²) and connect both to the blue wire from the transformer.
- 5 Use two green wires (0.24 mm²) and connect both to the green wire from the transducer.
- 6 Use one orange wire (0.24 mm²) and connect to the orange wire from the transducer.
- 7 Add crimp terminals to the end of the wires.
- 8 Install the crimp terminals in a Molex 8-pin receptacle according to the cable drawing.
 - a Connect the green wires to pin 1 and 5 on the receptacle.
 - b Connect the black wires to pin 3 and 7 on the receptacle.
 - c Connect the blue wires to pin 4 and 8 on the receptacle.
 - d Connect the orange wire to pin 6 on the receptacle.

This is now receptacle J1.
- 9 Connect receptacle J1 to connector P1 on the front of the PCB.

Installing the transducer cables TD80V

The cables can be provided with an optional cable kit.

Prerequisites

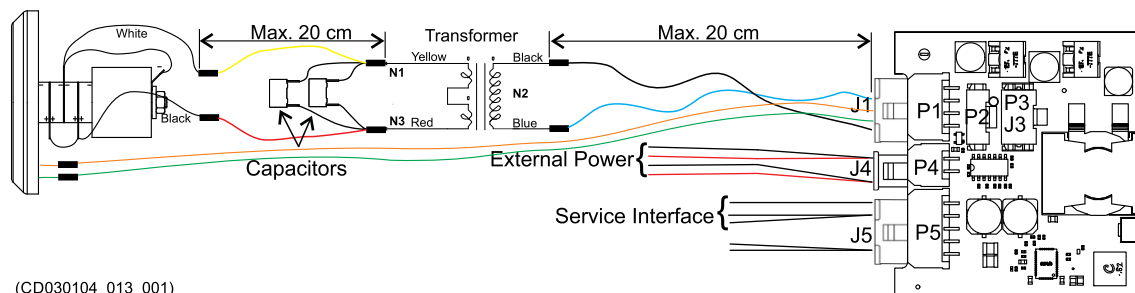

[Transducer connector pinout J1, page 15](#)

The following specific items are required for this task.

- 1 x Molex 8-pin receptacle 43025-0800
- 7 x Molex Female crimp terminal 43030-0008

Procedure

- 1 Use one yellow wire (0.5 mm²) and connect the white wire from the transducer with both capacitors and the yellow wire from the transformer.
- 2 Use one red wire (0.5 mm²) and connect the black wire from the transducer with both capacitors and the red wire from the transformer.
- 3 Use two black wires (0.5 mm²) and connect both to the black wire from the transformer.
- 4 Use two blue wires (0.5 mm²) and connect both to the blue wire from the transformer.
- 5 Use two green wires (0.24 mm²) and connect both to the green wire from the transducer.
- 6 Use one orange wire (0.24 mm²) and connect to the orange wire from the transducer.
- 7 Add crimp terminals to the end of the wires.
- 8 Install the crimp terminals in a Molex 8-pin receptacle according to the cable drawing.
 - a Connect the green wires to pin 1 and 5 on the receptacle.
 - b Connect the black wires to pin 3 and 7 on the receptacle.
 - c Connect the blue wires to pin 4 and 8 on the receptacle.
 - d Connect the orange wire to pin 6 on the receptacle.This is now receptacle J1.
- 9 Connect receptacle J1 to connector P1 on the front of the PCB.

Connectors

Transducer connector pinout J1

This is the pin configuration for a female plug, as seen towards the plug (face view).

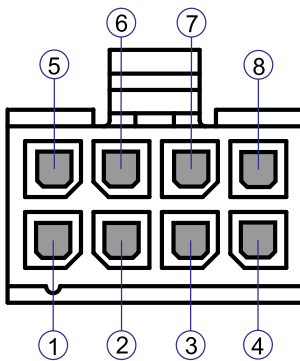

Pin number	Colour	Signal	Minimum requirements
1	Green	ID data	0.24 mm ²
2		Screen	
3	Black	TD +	0.5 mm ²
4	Blue	TD –	0.5 mm ²
5	Green	ID data	0.24 mm ²
6	Orange	Ground	0.24 mm ²
7	Black	TD +	0.5 mm ²
8	Blue	TD –	0.5 mm ²

Related topics

[Installing the transducer cables TD80V, page 13](#)

[Installing the transducer cables TD180, page 12](#)

Power connector J4

This is the pin configuration for a female plug, as seen towards the plug (face view).

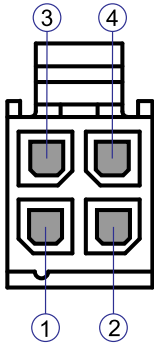

Pin number	Colour	Signal	Minimum requirements
1	Red	External power (24 VDC)	0.5 mm ²
2	Red	External power (24 VDC)	0.5 mm ²
3	Black	Ground	0.5 mm ²
4	Black	Ground	0.5 mm ²

Service connector J5

This is the pin configuration for a female plug, as seen towards the plug (face view).

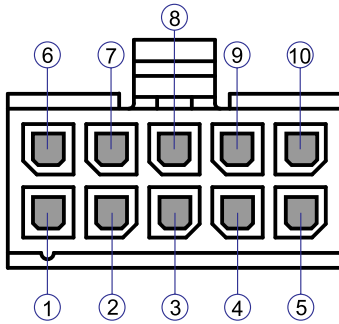

Pin number	Signal	Minimum requirements
1	Not connected	
2	Not connected	
3	Not connected	
4	Ground	0.5 mm ²
5	Not connected	
6	Not connected	
7	Not connected	
8	Not connected	
9	RS-232 Tx	0.5 mm ²
10	RS-232 Rx	0.5 mm ²

General acoustic considerations

Take this information into consideration when deploying the transponders.

Acoustic range

The depth rating should not be confused with acoustic range. The acoustic range is dependent on many factors, and some of the factors are outside control of the user.

Vessel system

The directivity and coverage area for the vessel system is different, depending on which system you are using. Some systems have high directivity and omnidirectional coverage, while other systems has reduced coverage and less directivity. The transponder should always be within the coverage cone of the vessel system.

Transducer type

There are different types of transducers used on the transponders. An omnidirectional transducer, such as TD180, covers a large area, but has less acoustic power compared to a focused transducer, such as TD30V. A focused signal gives less footprint/coverage. The vessel should always be within the signal footprint of the transponder.

Tx Power

The ability to detect signals depends on the signal strength. The transmission power can be adjusted, both for the vessel system and for the transponder.

Acoustic noise

Acoustic noise is present at all vessels. At given conditions, the noise level can be excessive. Acoustic noise is caused by main propellers and thrusters, and in some instances also from machinery and/or pumps on board. Heavy propeller/thruster use or also waves can also generate air bubbles, which can get in front of the vessel transducer and block the acoustic signal.

Sound velocity and ray bending

Changes in sound velocity through the water column caused by changes in the water temperature and/or salinity can bend the acoustic signal and make it impossible to reach the vessel.

Operating procedures

The transponder is operated from the HiPAP operator station APOS.

- Refer to APOS online help for descriptions.

Spare parts

Topics

[TD180 Spare part, page 22](#)

[TD80V Spare part, page 22](#)

[Printed Circuit Board \(PCB\) Spare part, page 22](#)

[Capacitor Spare part, page 22](#)

[Transformer TD180 Spare part, page 22](#)

[Transformer TD80V Spare part, page 23](#)

[Cable kit Spare part, page 23](#)

TD180 Spare part

- **Part name:** TD180
- **Part number:** 417492

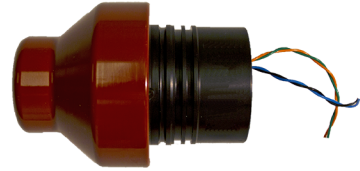

TD80V Spare part

- **Part name:** TD80V
- **Part number:** 350501



Printed Circuit Board (PCB) Spare part

- **Part name:** cNODE Embed Printed Circuit Board (PCB)
- **Part number:** 423908

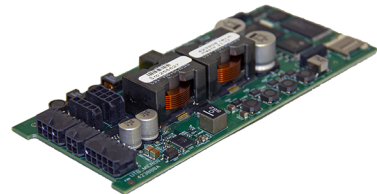

Capacitor Spare part

- **Part name:** cNODE Embed Capacitor
- **Part number:** 212-076626



Transformer TD180 Spare part

- **Part name:** Transformer TD180
- **Part number:** 412432

Transformer TD80V Spare part

- **Part name:** Transformer TD80V
- **Part number:** 402399

Cable kit Spare part

The cable kit contains the following items

- Receptacle J1 with 150 mm wires.
- Receptacle J4 with 150 mm wires.
- Receptacle J5 with 150 mm wires.
- **Part name:** cNODE Embed Cable kit
- **Part number:** 430973

Technical specifications

Topics

[Performance specifications, page 25](#)

[Weight and outline dimensions, page 26](#)

[Power requirements, page 27](#)

[Environmental requirements, page 27](#)

Performance specifications

These performance specifications summarize the main functional and operational characteristics of the cNODE Embed Embed.

- **Operational frequency:** 21 - 31 kHz
- **Responder trigger signal:** 5 - 25 V positive logic pulse (2 - 6 ms)
- **Depth rating:** 3000 m
- **Internal tilt sensor:** $\pm 90^\circ$

TD80V

- **Transducer beam:** 80° Vertical
- **Receiver sensitivity:** 85 dB
- **Source level:**
 - Maximum: 188 dB
 - High: 182 dB
 - Low: 176 dB
 - Minimum: 171 dB

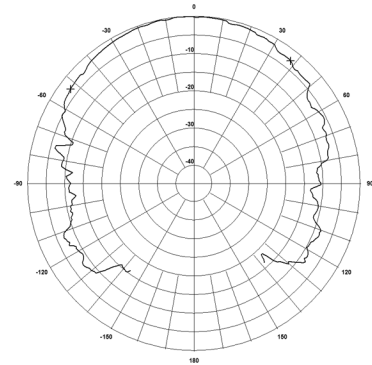

TD180

- **Transducer beam:** 180°
- **Receiver sensitivity:** 100 dB
- **Source level:**
 - Maximum: 190 dB
 - High: 184 dB
 - Low: 178 dB
 - Minimum: 173 dB

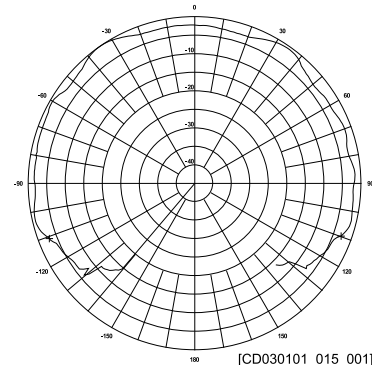

Weight and outline dimensions

These weights and outline dimension characteristics summarize the physical properties of the cNODE Embed system.

Printed Circuit Board (PCB)

- **Outline dimensions:**
 - **Height:** 142 mm
 - **Width:** 63 mm
 - **Depth:** 22 mm

TD80V

- **Outline dimensions:**
 - **Height:** 57.7 mm
 - **Diameter:** 68 mm

TD180

- **Outline dimensions:**
 - **Height:** 70.5 mm
 - **Diameter:** 88 mm

Capacitor

- **Outline dimensions:**
 - **Height:** 18 mm
 - **Width:** 5 mm
 - **Depth:** 10.5 mm

Transformer

- **Outline dimensions:**
 - **Height:** 32 mm
 - **Diameter:** 42 mm

Power requirements

These power characteristics summarize the supply power requirements for the cNODE Embed system.

- **Voltage requirement:** 22.5–29.5 VDC
- **Nominal voltage:** 24 VDC
- **Transmit power:** 250 W
- **Standby power:** < 100 mW

Environmental requirements

These specifications summarize the temperature requirements and other environmental standards for the cNODE Embed system.

- **Operating temperature:** -5 to 55 °C
- **Storage temperature:** -30 to 70 °C

Drawing file

Topics

[TD80V Outline dimensions, page 29](#)

[TD180 Outline dimensions, page 30](#)

[PCB Outline dimensions, page 31](#)

[cNODE Embed TD80V Low wiring diagram, page 32](#)

[cNODE Embed TD180 wiring diagram, page 33](#)

TD80V Outline dimensions

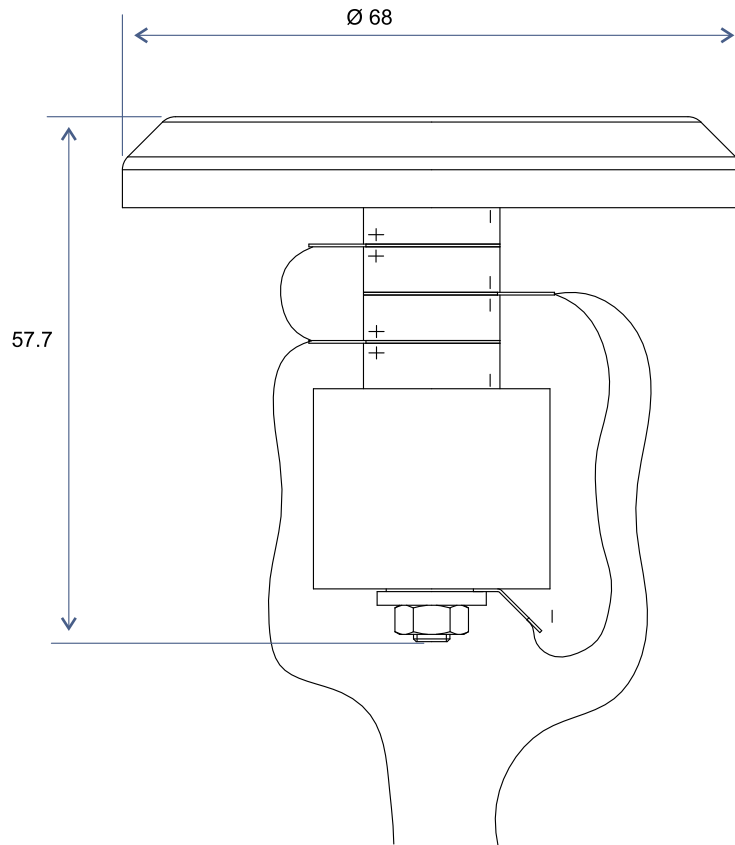

All measurements in mm.
The drawing is not in scale.

350501 Rev. B
CD12_350501_001_001

TD180 Outline dimensions

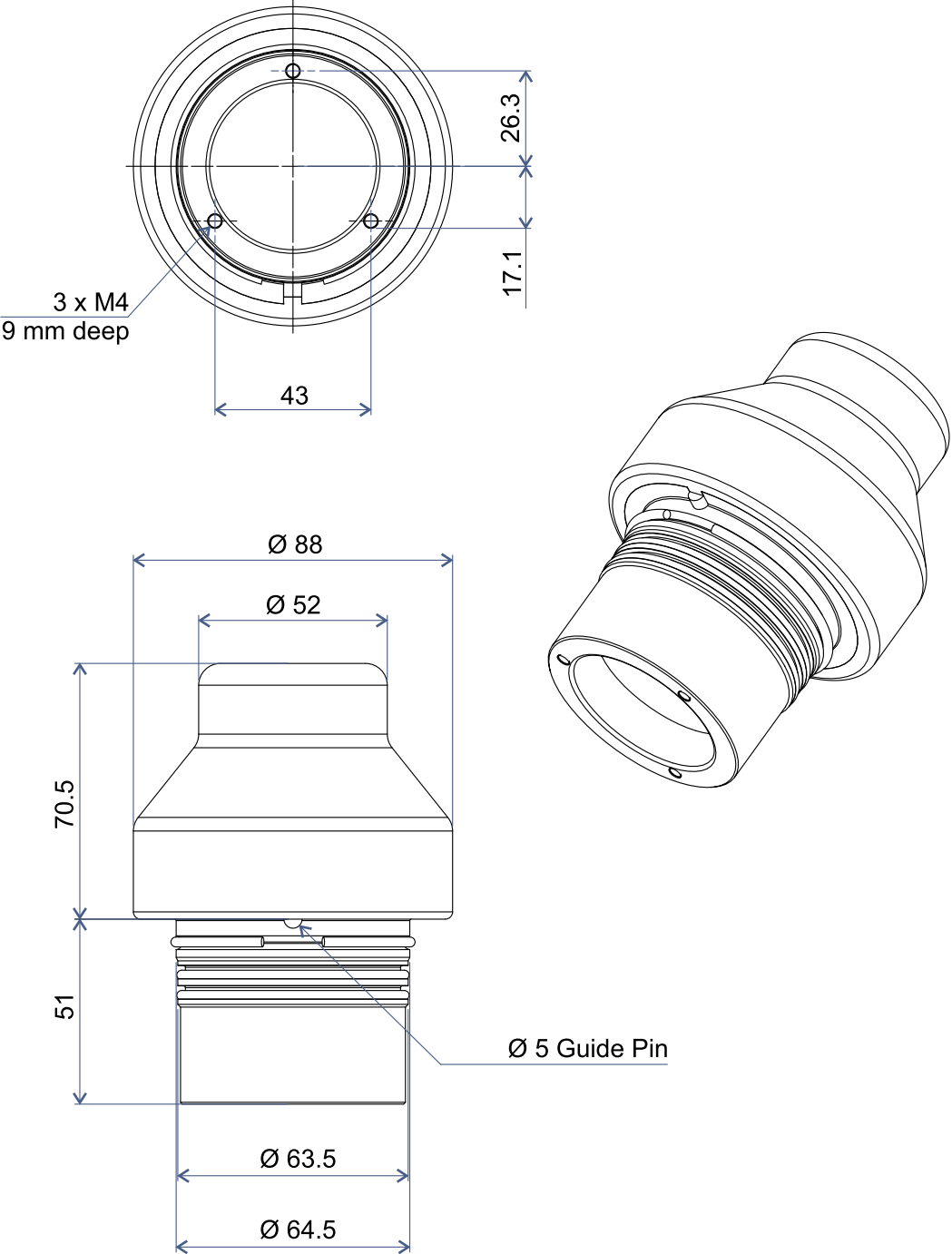

All measurements in mm.
The drawing is not in scale.

[436632] Rev.A
CD12_436632_001_001

PCB Outline dimensions

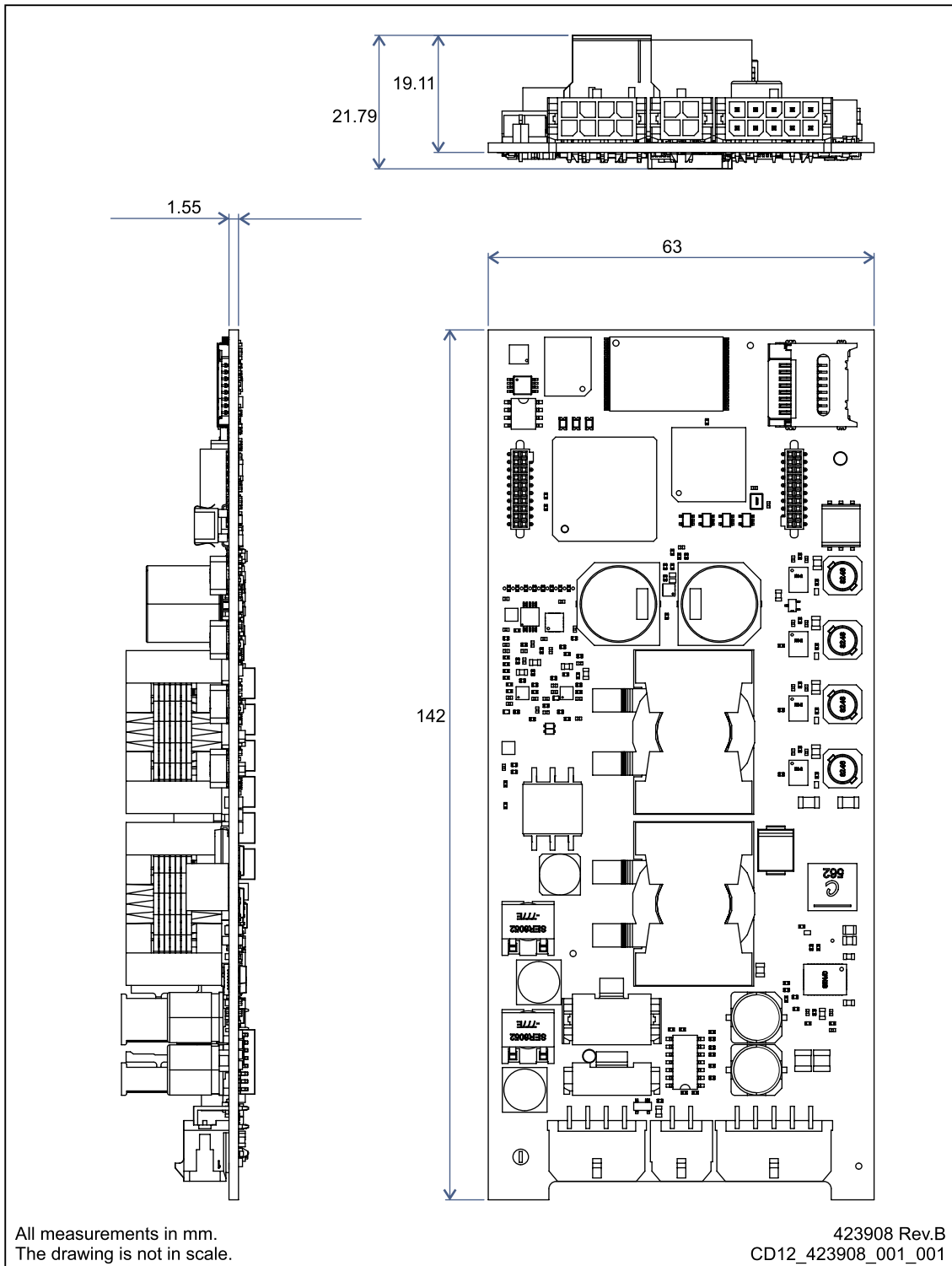

cNODE Embed TD80V Low wiring diagram

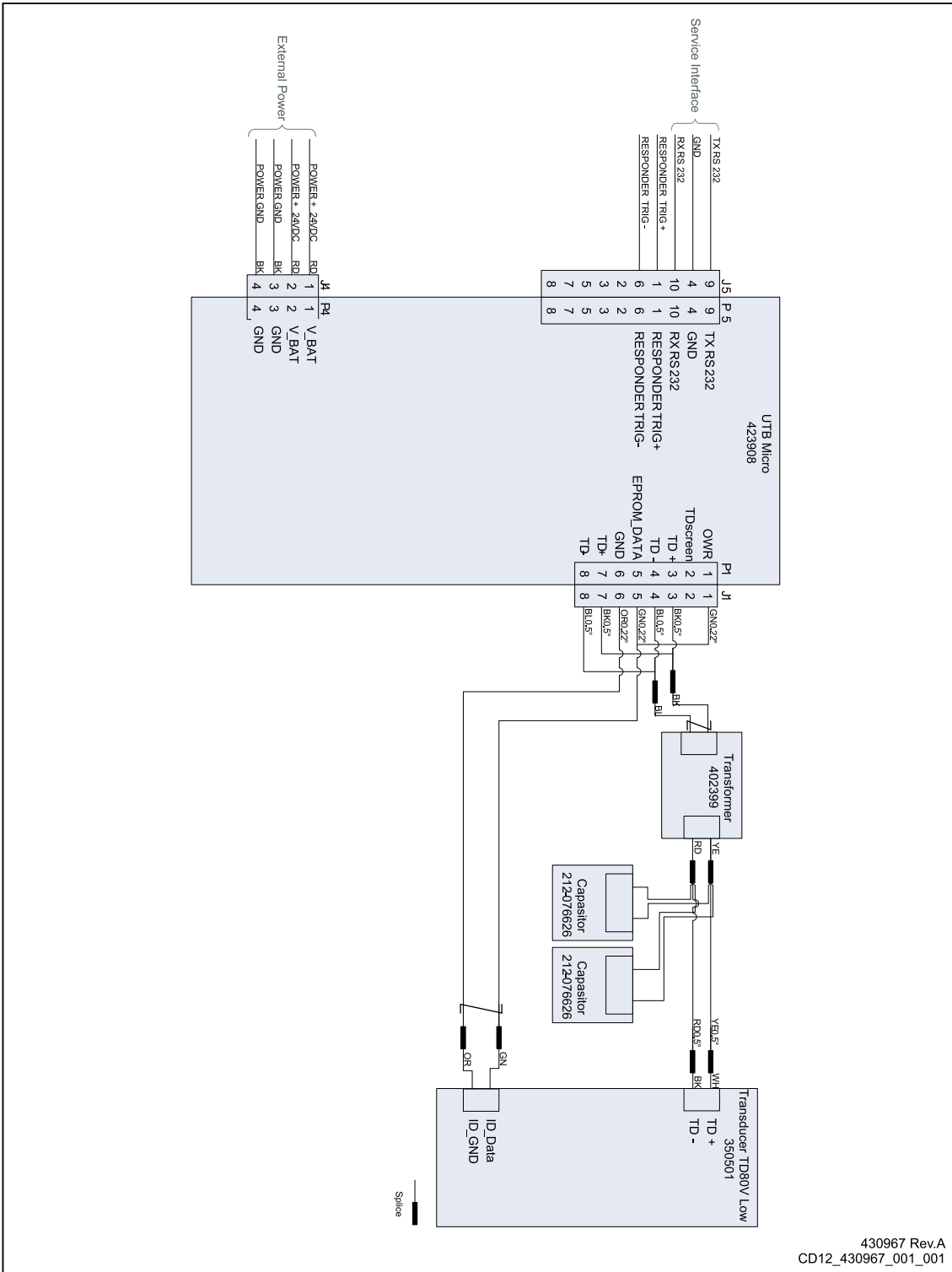

cNODE Embed TD180 wiring diagram

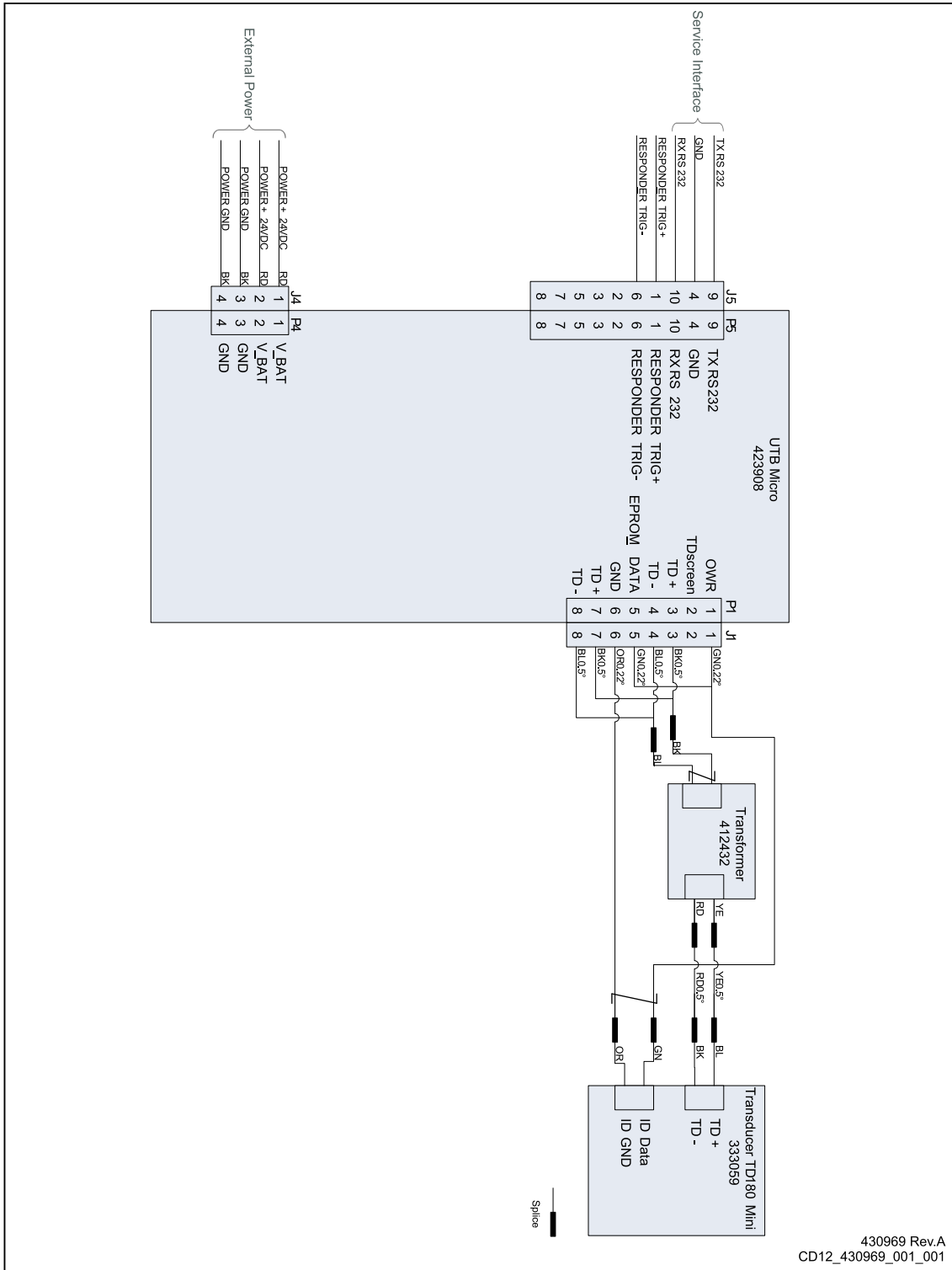

430969 Rev.A
CD12_430969_001_001

Index

212-076626		
capacitor.....	22	
350501		
TD80V	22	
402399		
transformer.....	22-23	
412432		
transformer.....	22-23	
417492		
TD180	22	
423908		
PCB.....	22	
A		
about		
acoustic considerations.....	18	
acoustic range	18	
document downloads.....	5	
electrostatic discharge (ESD).....	10	
online information	5	
purpose of this manual	5	
registered trademarks.....	5	
target audience	5	
transducer type	18	
vessel system	18	
acoustic considerations		
about.....	18	
acoustic range		
about.....	18	
audience		
this manual.....	5	
B		
basic items		
provided with the delivery.....	7	
book		
purpose	5	
target audience	5	
C		
cable installation		
prerequisites	11-13	
cable kit		
spare part.....	23	
capacitor		
212-076626	22	
spare part.....	22	
caution		
ESD (electrostatic discharge).....	10	
characteristics		
performance	25	
connector		
pin out	15-17	
signal pin number.....	15-17	
D		
description		
system	7	
dimensions		
technical specifications.....	26	
documents		
download from website	5	
download		
documents from website.....	5	
E		
electrostatic discharge (ESD)		
about.....	10	
caution.....	10	
preventing.....	11	
what is it?	10	
environmental		
requirements.....	27	
equipment		
handling	7	
receipt	7	
storage.....	7	
ESD (electrostatic discharge)		
about.....	10	
caution.....	10	
preventing.....	11	
what is it?	10	
G		
general supply conditions		
receipt	7	
storage.....	7	
unpacking.....	7	
H		
help		
support offices.....	8	
I		
information		
online	5	
support	8	
installation of cables		
prerequisites	11-13	
installation requirements		
environmental	27	
temperature	27	
M		
main items		
provided with the delivery.....	7	
manual		
purpose	5	
target audience	5	

- O**
- offices
 - support 8
 - online
 - information 5
 - order number
 - cable kit 23
 - capacitor 22
 - PCB 22
 - TD180 22
 - TD80V 22
 - transformer 22–23
 - outline dimensions
 - technical specifications 26
- P**
- part number
 - cable kit 23
 - capacitor 22
 - PCB 22
 - TD180 22
 - TD80V 22
 - transformer 22–23
 - PCB
 - 423908 22
 - spare part 22
 - performance
 - specifications 25
 - pin out
 - connector 15–17
 - power
 - requirements 27
 - precautions
 - electrostatic discharge (ESD) 11
 - prerequisites
 - cable installation 11–13
 - preventing
 - electrostatic discharge (ESD) 11
 - publication
 - purpose 5
 - target audience 5
 - purpose
 - this manual 5
- R**
- reader
 - this manual 5
 - receipt
 - general supply conditions 7
 - registered trademarks 5
 - requirements
 - environmental 27
 - power 27
 - temperature 27
- S**
- scope of supply
 - basic items 7
 - size
 - technical specifications 26
- spare part
 - cable kit 23
 - capacitor 22
 - PCB 22
 - TD180 22
 - TD80V 22
 - transformer 22–23
- specifications
 - outline dimensions 26
 - performance 25
 - weight 26
- standard items
 - provided with the delivery 7
- storage
 - general supply conditions 7
- supply conditions
 - receipt 7
 - storage 7
 - unpacking 7
- support information 8
- system
 - description 7
- T**
- target audience
 - this manual 5
 - TD180
 - 417492 22
 - spare part 22
 - TD80V
 - 350501 22
 - spare part 22
 - technical requirements
 - power 27
 - technical specifications
 - outline dimensions 26
 - weight 26
 - technical support
 - offices 8
 - temperature
 - requirements 27
 - this manual
 - purpose 5
 - target audience 5
 - trademarks
 - registered 5
 - transducer type
 - about 18
 - transformer
 - 402399 22–23
 - 412432 22–23
 - spare part 22–23
- U**
- unpacking
 - general supply conditions 7
- V**
- vessel system
 - about 18

W

website	
download documents	5
weight	
technical specifications.....	26
what is	
electrostatic discharge (ESD)	10
wiring	
prerequisites	11–13

©2020 Kongsberg Maritime