

Installation manual

Simrad 50-7 50 kHz Single beam transducer



Simrad 50-7

Installation manual

This document provides a general description of how to install the Simrad 50-7 Single beam transducer. The information must be regarded as general guidelines and recommendations only. The installation shipyard must design and manufacture installation hardware to fit the 50-7 transducer on each individual vessel.

Document history

Document number: 305270 / ISBN-10: 82-8066-075-5 / ISBN-13: 978-82-8066-075-6		
Rev.A	August 2006	Original issue.

Copyright

©2006 Simrad Horten AS

Disclaimer

The information contained in this document remains the sole property of Simrad Horten AS. No part of this document may be copied or reproduced in any form or by any means, and the information contained within it is not to be communicated to a third party, without the prior written consent of Simrad Horten AS. Simrad Horten AS endeavours to ensure that all information in this document is correct and fairly stated, but does not accept liability for any errors or omissions.

Warning

The equipment to which this manual applies must only be used for the purpose for which it was designed. Improper use or maintenance may cause damage to the equipment and/or injury to personnel. The user must be familiar with the contents of the appropriate manuals before attempting to operate or work on the equipment. Simrad disclaims any responsibility for damage or injury caused by improper installation, use or maintenance of the equipment.

Support

If you require maintenance on your Simrad equipment, contact your local dealer. You can also contact Simrad using the following e-mail address:
e-mail: contact@simrad.com

Simrad Horten AS

Strandpromenaden 50
P.O.Box 111
N-3191 Horten,
Norway

Telephone: +47 33 03 40 00
Telefax: +47 33 04 29 87
www.simrad.com
simrad.sales@simrad.com

SIMRAD
A KONGSBERG Company

Table of contents

INTRODUCTION	5
TRANSDUCER LOCATION	6
Go deep.....	6
Vessel heave	6
Noise from protruding objects on the hull.....	6
Boundary water layer	7
Propeller noise.....	7
Inclination of the transducer face	8
Summary and general recommendation	8
WAYS OF MOUNTING THE TRANSDUCER	10
Transducer blister	11
Box keel.....	17
Flush mounting in a steel tank.....	19
Acoustic window	21
Inside the hull	23
Drop keel	25
Retractable transducer	26
CABLE GLANDS	27
Order numbers	27
Cable gland for steel hulls	28
Cable gland for wood or GRP hulls	29
Cable glands for small hulls	30
Cable splicing	31
STEEL CONDUIT	32
HANDLING AND MAINTENANCE	33
Approved anti-fouling paints.....	34
DRAWING FILE	35
Single frequency, single beam, low power transducer connection.....	36
Outline dimensions.....	37
Mounting arrangement	38
Mounting ring.....	40
Blister assembly	42
Blister design.....	44

INTRODUCTION

The purpose of this manual is to provide the basic information required to install the 50-7 Single beam transducer.

Note that although drawings are provided to explain the installation principles, the installation shipyard must provide the final drawings required to fit each individual vessel. Also, when applicable, the installation shipyard must have the drawings and installation approved by the proper authorities.

Transducer order number: **KSV-203665**.

A cable gland kit for steel hull is included with the delivery. Other cable glands must be ordered separately.

Transducer installation

The next chapter in this manual provides general guidelines for transducer installation. The drawings specific for the 50-7 transducer are located in the *Drawing file*.

Technical specifications

Refer to the 50-7 Product specification.

Additional parts

The following items can be supplied by Simrad to facilitate installation:

- **Mounting ring:** Order number 499–203336
- **Transducer cable** (for extension): Order number 642–016604

TRANSDUCER LOCATION

A single answer to the question where to locate the transducer cannot be given. It depends very much on the vessel's construction. However, there are some important guide lines.

Go deep

The upper water layers of the sea contain a myriad of small air bubbles created by the breaking waves. In heavy seas the uppermost 5 to 10 metres may be air-filled, with the highest concentrations near the surface. Air bubbles absorb and reflect the sound energy, and may in worst cases block the sound transmission totally. Therefore, mount the transducer at a deep position on the hull.

Consider the situation when the vessel is unloaded, and when it is pitching in heavy seas.

WARNING

The transducer must never be lifted free of the water surface.

Not only will the sound transmission be blocked, but the transducer may be damaged by slamming against the sea surface.

Another reason to go deep is cavitation in front of high power transducers. Cavitation is the formation of small bubbles in the water due to the resulting local pressure becoming negative during parts of the acoustic pressure cycles. The cavitation threshold increases with the hydrostatic pressure.

Vessel heave

Heave is the up and down movement of the vessel. It disturbs the echo traces in the echogram, so that a flat bottom is displayed as a wave. A transducer location in the middle of the vessel minimises the influence of vessel roll and pitch.

Noise from protruding objects on the hull

Objects protruding from the hull, such as zinc anodes, sonar transducers or even the vessel's keel, generate turbulence and flow noise. Also holes and pipe outlets are noise sources. They may act as resonant cavities amplifying the flow noise at certain frequencies. Do not place an echo sounder transducer in the vicinity of such objects, and especially not close behind them.

For the same reason, it is very important that the hull area around the transducer face is as smooth and level as possible. Even traces of sealing compound, sharp edges, protruding bolts or bolt holes without filling compound will create noise.

Boundary water layer

When the vessel forces its way through the sea, the friction between the hull and the water creates a boundary layer. The thickness of the boundary layer depends upon vessel speed and the roughness of the hull. Objects protruding from the hull, and dents in the hull, disturb the flow and increase the thickness of the boundary layer. The flow in this boundary layer may be laminar or turbulent. A laminar flow is a nicely ordered, parallel movement of the water. A turbulent flow has a disorderly pattern, full of eddies. The boundary layer increases in thickness when the flow goes from laminar to turbulent. The figure below illustrates the boundary layer of a vessel moving through the water.

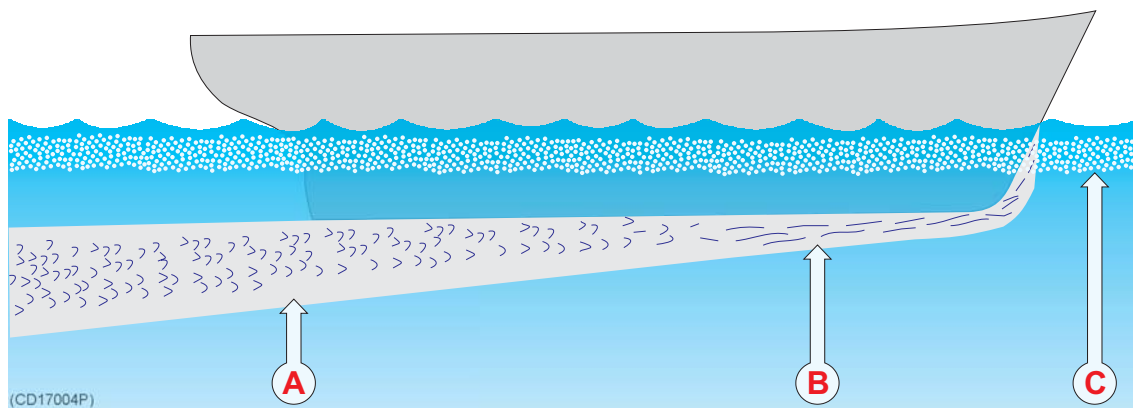

Boundary water layers:

(A) = *Turbulent flow*

(B) = *Laminar flow*

(C) = *Air bubbles in the water*

Furthermore, air bubbles in the sea water are pressed down below the hull and mixed into the boundary layer. The boundary layer is thin underneath the forward part of the vessel, and increases in thickness as it moves towards aft. If the sides of the hull are steep, some of the air bubbles in the boundary layer may escape to the sea surface along the vessel sides. It is our experience that a wide and flat bottom, with a rising angle less than around 13 degrees, is prone to giving air problems for the transducer. In any case a transducer location in the forward part of the hull is preferred in order to minimise the influence of the boundary layer.

Propeller noise

The propulsion propeller is the dominant noise source on most fishing vessels, research vessels, merchant vessels and pleasure crafts. The noise is transmitted through the sea water. For this reason, the transducer should be placed far away from the propeller, which means on the fore part of the hull. Positions

outside the direct line of sight from the propeller are favourable. On small vessels with short distances it is advised to mount the transducer on that side of the keel where the propeller blades move upwards, because the propeller cavitation is strongest on the other side. The cavitation starts most easily when the water flows in the same direction as the propeller blade, and that is to some degree the case at that side of the keel where the propeller blades move downwards.

Bow thruster propellers are extremely noisy. When in operation, the noise and cavitation bubbles make the echo sounder useless, almost no matter where the transducer is installed. And when not in operation, the tunnel creates turbulence, and if the vessel is pitching, the tunnel may be filled with air or aerated water in the upper position and release this in the lower position. Therefore, an echo sounder transducer should be placed well away from the bow thruster.

Inclination of the transducer face

Ideally, the transducer face should be mounted in parallel with the sea surface when the vessel is in normal trim, as this will provide the most accurate echo information. However, it is also very important that the water flow over the transducer face is laminar.

In order to ensure laminar flow, the transducer face may be tilted slightly upwards in relation to the water flow. This allows the flowing water to meet the face directly, and assures laminar flow. The inclination angle must however be determined carefully. The angle must be small on transducers with narrow beam angles. As a rule of thumb, mount transducers with beam angles smaller than seven degrees with minimum inclination angle. The smaller beam angle your transducer has, the smaller the inclination angle can be.

Ensure that you do not mount the transducer with a negative inclination angle. This may cause turbulence under the transducer face, and reduced echo sounder performance.

Summary and general recommendation

Some of the above guide lines are conflicting, and each case has to be treated individually in order to find the best compromise. Generally the propeller noise is the dominant factor, and a recommended transducer location is in the fore part of the hull, with maximum distance from the bow equal to one third of the total length of the hull at the water line.

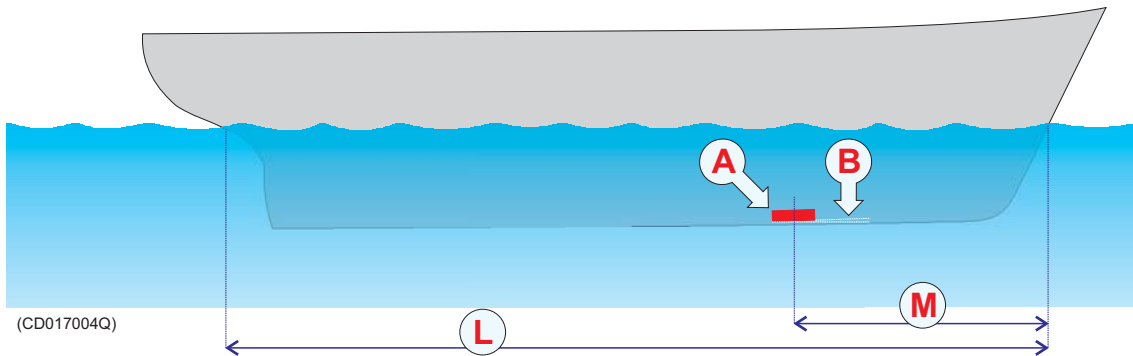

General recommendation for transducer location:

(A) = Transducer

(B) = Inclination angle

(L) = Hull length at water line

(M) = Maximum 1/3 of the hull length at water line (L)

If the vessel hull has a bulbous bow, this may well be a good transducer location, but also here must be taken into consideration the flow pattern of the aerated water. Often the foremost part of the bulb is preferable.

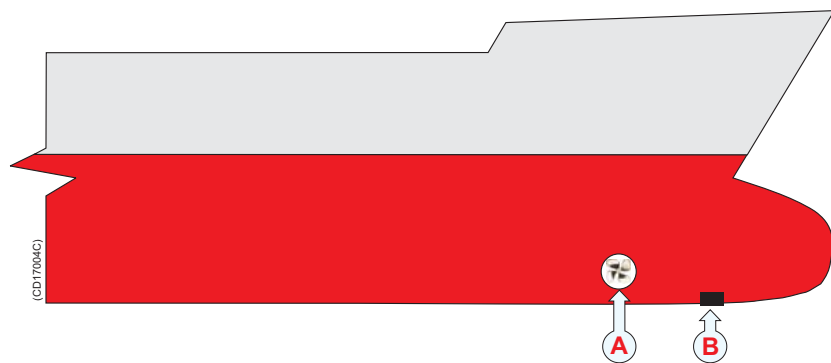

Recommended location of the transducer on a bulbous hull:

(A) = Thruster

(B) = Transducer location

WAYS OF MOUNTING THE TRANSDUCER

There are many different ways to mount the transducer. These are the recommended methods to mount a circular transducer.

Topics

Transducer blister on page 11

Box keel on page 17

Flush mounting in a steel tank on page 19

Acoustic window on page 21

Inside the hull on page 23

Drop keel on page 25

Retractable transducer on page 26

Transducer blister

With a transducer with circular housing, one recommended installation method is by using a blister. The transducer blister must be designed and manufactured by the installation shipyard to fit the vessel's size and hull shape.

Mounting and clamping rings

Circular transducers may be provided with mounting and clamping rings, or with drawings to allow for local production of these. The mounting ring is welded to the hole in the transducer blister, while the clamping ring fits around the edge of the transducer body. Bolts through the clamping ring into the mounting ring will then secure the transducer between them. Note that several transducers use direction guides to allow correct mounting.

Smooth surface

Mounting screws or bolts must not be extruding from the transducer blister. Ensure that the surface of the transducer face, the blister, the hull plating and putty around the transducer is as even and smooth as possible. Obstructions on these surfaces will create problems with turbulent flow.

Horizontal support bar

Large diameter transducers must be fitted with a horizontal support bar. This bar can be secured to the mounting ring using threaded rods.

Example: Large transducer

The illustration below shows a typical transducer blister designed for a large transducer. Note that due to the physical size of the transducer, a U-shaped support bar (E) is used to support the transducer. The purpose of this support is to prevent the transducer from being pushed up into the blister in heavy seas.

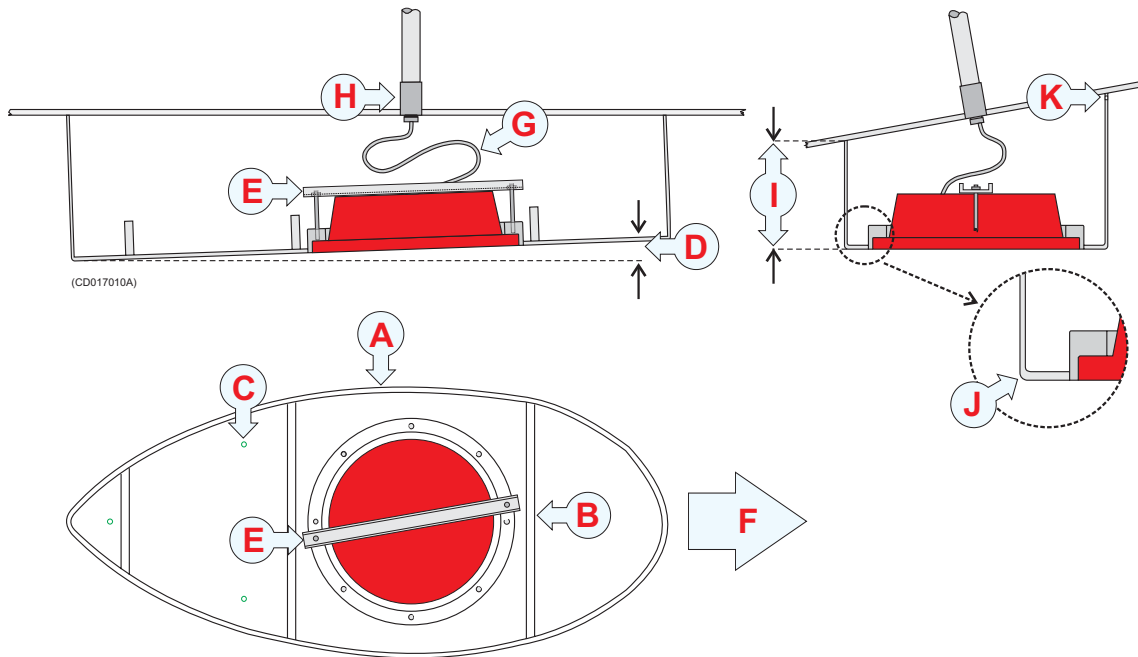

- | | |
|----------------------------|--------------------------|
| (A) = Streamlined blister | (G) = Cable service loop |
| (B) = Stiffening rib | (H) = Stuffing tube |
| (C) = Drainage holes | (I) = Minimum 400 mm |
| (D) = Inclination angle | (J) = Rounded corners |
| (E) = U-shaped support bar | (K) = Air outlet |
| (F) = Forward | |

Example: Small transducer

The illustration below shows a typical transducer blister designed for a small transducer. The same blister design principles as for a large transducer apply.

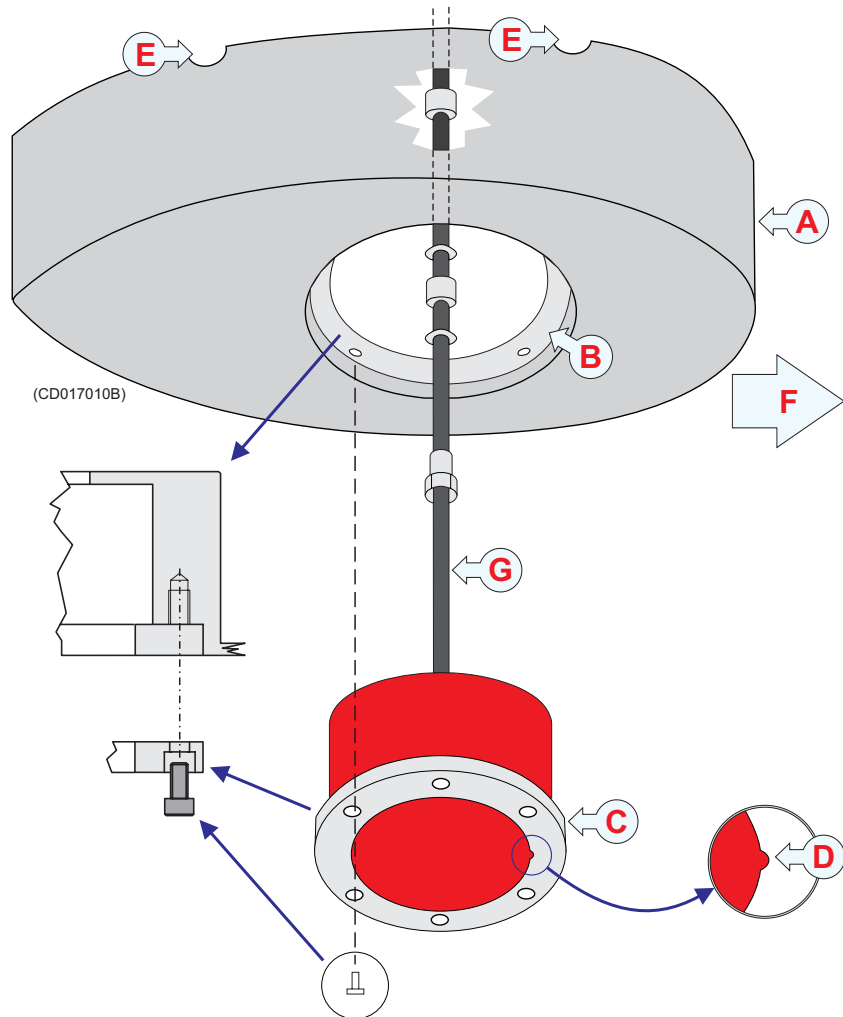

- (A) = Streamlined blister
- (B) = Mounting ring
- (C) = Clamping ring
- (D) = Guide
- (E) = Air outlet
- (F) = Forward
- (G) = Transducer cable

Note that the transducer cable must be provided with a cable loop inside the blister. Observe the vertical forward edge of the blister. This will guide the water to each side of the blister.

Example: Medium sized transducer without clamping ring

The illustration below shows a transducer blister designed for a medium sized transducers. The same blister design principles apply. Note that the transducer is mounted without a clamping ring, which makes it necessary to use a different mounting ring design.

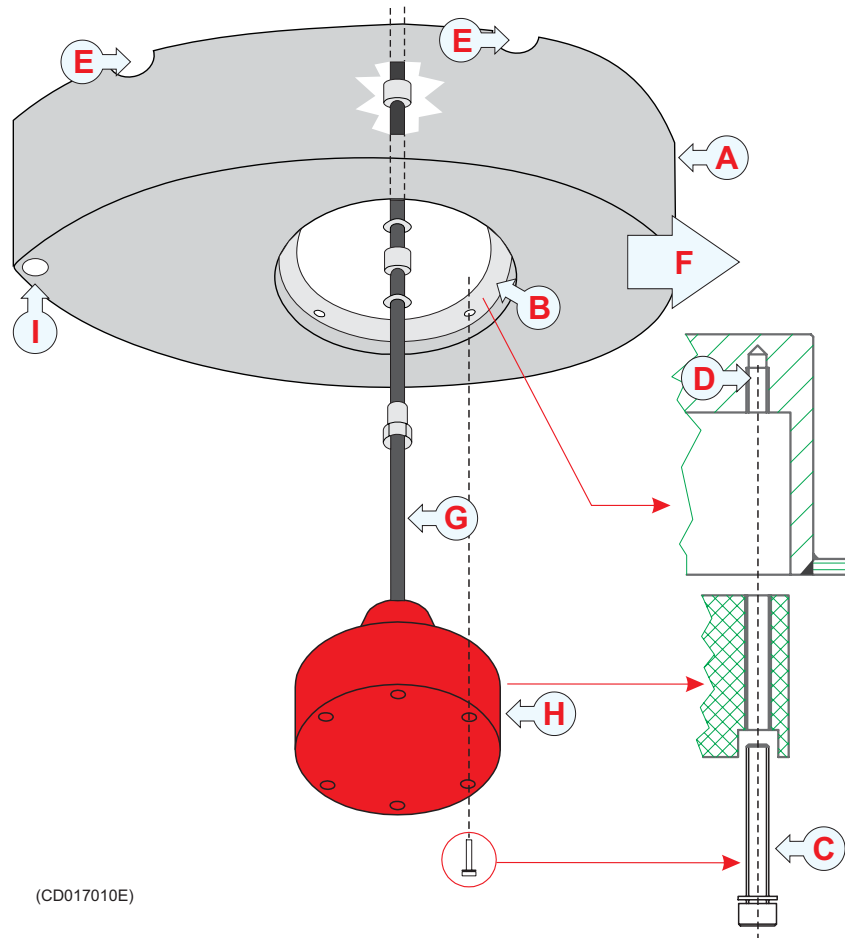

- | | |
|----------------------------|------------------------|
| (A) = Streamlined blister | (E) = Air outlet |
| (B) = Mounting ring | (F) = Forward |
| (C) = Bolt | (G) = Transducer cable |
| (D) = Self-locking threads | (H) = Transducer |

Note that the transducer cable must be provided with a cable loop inside the blister. Observe the vertical forward edge of the blister. This will guide the water to each side of the blister.

Common guidelines

The best performance is obtained with a blister height of 40 cm or more. A streamlined shape and rounded edges reduce the flow noise. A vertical leading edge or front will guide the aerated water to the sides of the blister. The orientation of the blister should follow the water flow.

The interior of the blister must be filled with sea water. Use drainage holes in the bottom and an air outlet on the top. The water pressure behind the transducer will then compensate for the outside pressure during vessel movements in rough sea.

Large diameter transducers must be fitted with a horizontal U-shaped support bar. This bar can then be secured to the mounting ring using threaded rods.

The transducer cable penetrates the hull in a stuffing tube. Leave an adequate loop of the cable behind the transducer for easy mounting or removal of the transducer.

Toe-in

The primary consideration must be to allow laminar water flow. In most cases this is achieved by designing the blister in parallel with the keel. However, if the blister is located close to the bow, the front of the blister may have a few degrees toe-in towards the bow.

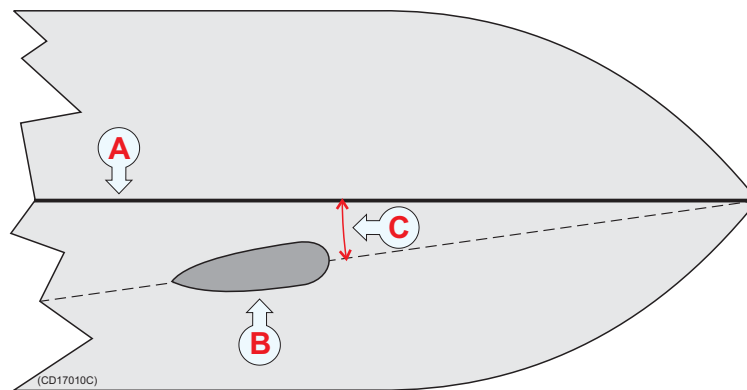

(A) = Keel

(B) = Blister

(C) = Toe-in angle

Physical location

The blister is placed on one of the sides of the hull, and the distance from the keel is a trade off between a close distance giving a turbulent flow of water in a narrow passage, and a large distance bringing the transducer higher up and also more affected by vessel roll. Normally a distance of approximately 1 m is a good compromise.

Observe the horizontal and vertical distances (X and Y) between the keel and the transducer blister. On a medium sized vessel, the horizontal distance (X) should be approximately 1 meter. The vertical distance (Y) must in general be as small as possible. This is important to prevent the keel from shadowing the transducer beam in shallow waters.

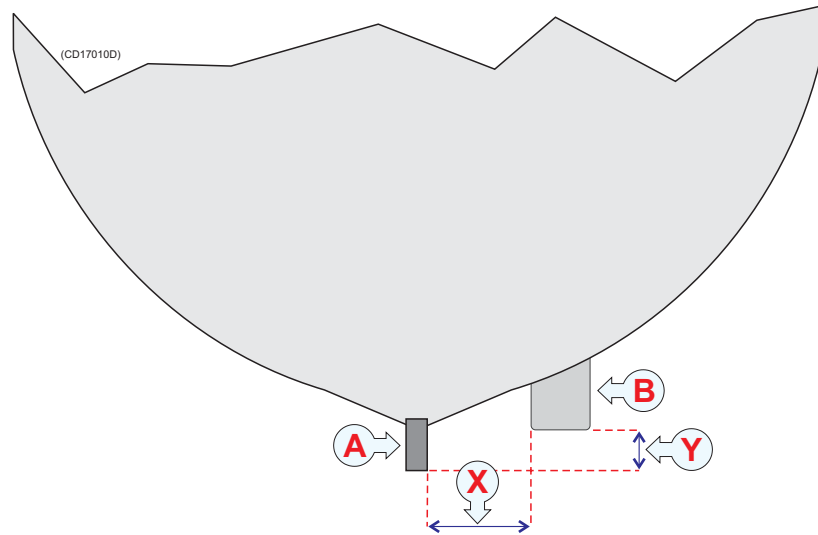

(A) = Keel

(B) = Transducer blister

(X) = Horizontal distance between keel and blister

(Y) = Vertical distance between the blister surface and the keel

Box keel

Vessels with a box keel may use this for transducer installation.

The box keel is already the deepest part of the vessel. If the box keel is too narrow to accommodate the transducer, it can be widened, either symmetrically or to one side only. In the last case the installation could also be described as a blister merged into the keel.

Mounting and clamping rings

Circular transducers may be provided with mounting and clamping rings, or with drawings to allow for local production of these. The mounting ring is welded to the hole in the box keel, while the clamping ring fits around the edge of the transducer body. Bolts through the clamping ring into the mounting ring will then secure the transducer between them. Note that several transducers use direction guides to allow correct mounting.

Smooth surface

Mounting screws or bolts must not be extruding from the box keel. Ensure that the surface of the transducer face, the box, the hull plating and putty around the transducer is as even and smooth as possible. Obstructions on these surfaces will create problems with turbulent flow.

Horizontal support bar

Large diameter transducers must be fitted with a horizontal support bar. This bar can be secured to the mounting ring using threaded rods.

Example

The figure below illustrates a symmetrical box keel installation.

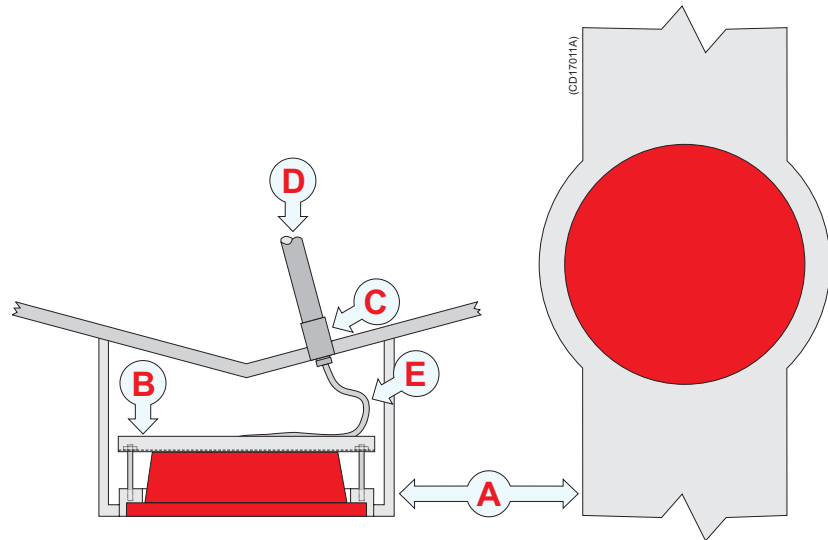

(A) = *Box keel*

(B) = *U-shaped support bar (only required on large transducers)*

(C) = *Stuffing tube*

(D) = *Cable in steel conduit*

(E) = *Cable service loop*

Flush mounting in a steel tank

Flush mounting is used on very large vessels with a hull so deep that no air bubbles are found below the hull, and on vessels operating in shallow harbours or waters, where a protruding blister can not be accepted.

The standard procedure for flush mounting on a steel vessel is to weld a steel tank inside the hull, and mount the transducer into this tank.

Mounting and clamping rings

Circular transducers may be provided with mounting and clamping rings, or with drawings to allow for local production of these. The mounting ring is welded to the hole in the hull plating, while the clamping ring fits around the edge of the transducer body. Bolts through the clamping ring into the mounting ring will then secure the transducer between them. Note that several transducers use direction guides to allow correct mounting.

Smooth surface

Mounting screws or bolts must not be extruding from the hull plating. Ensure that the surface of the transducer face, the hull plating and putty around the transducer is as even and smooth as possible. Obstructions on these surfaces will create problems with turbulent flow.

Horizontal support bar

Large diameter transducers must be fitted with a horizontal support bar. This bar can be secured to the mounting ring using threaded rods.

Water filled

As for a blister, the interior of the tank must be filled with water. This can be accomplished by air release through a steel tube, which is extended either to open air 1.5 m above the water line or to the water outside the hull at a point higher than the tank interior. If the tube is extended to open air, drainage must be provided with leakage at the transducer flange or a separate hole in the tank bottom.

Example

Transducer mounting in a steel tank is shown in the figure below.

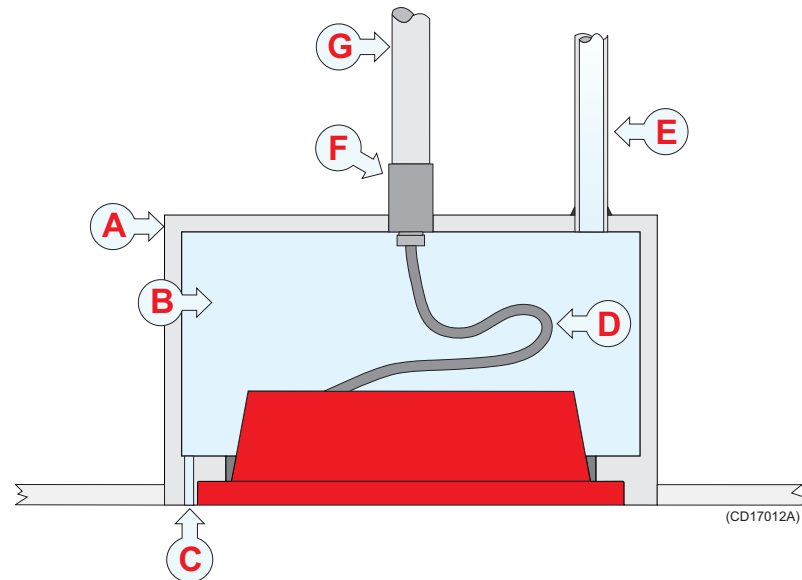

- (A) = Steel tank
- (B) = Water
- (C) = Drainage hole
- (D) = Cable service loop
- (E) = Steel tube for air outlet
- (F) = Stuffing tube
- (G) = Cable in steel conduit

Acoustic window

Vessels operating in arctic waters need special attention on transducer installation. Floating blocks of ice may damage even a flush mounted transducer face. For this situation Simrad offers arctic tanks in different sizes.

Mounting and clamping rings

Circular transducers may be provided with mounting and clamping rings, or with drawings to allow for local production of these. The mounting ring is welded to the hole inside the steel tank, while the clamping ring fits around the edge of the transducer body. Bolts through the clamping ring into the mounting ring will then secure the transducer between them. Note that several transducers use direction guides to allow correct mounting.

Smooth surface

Mounting screws or bolts must not be extruding from the acoustic window. Ensure that the surface of the window, the hull plating and putty around the transducer is as even and smooth as possible. Obstructions on these surfaces will create problems with turbulent flow.

Horizontal support bar

Large diameter transducers must be fitted with a horizontal support bar. This bar can be secured to the mounting ring using threaded rods.

Example

The transducer shown in the figure below is mounted inside the tank behind a strong acoustic window which could be made of polycarbonate. The tank is filled with oil.

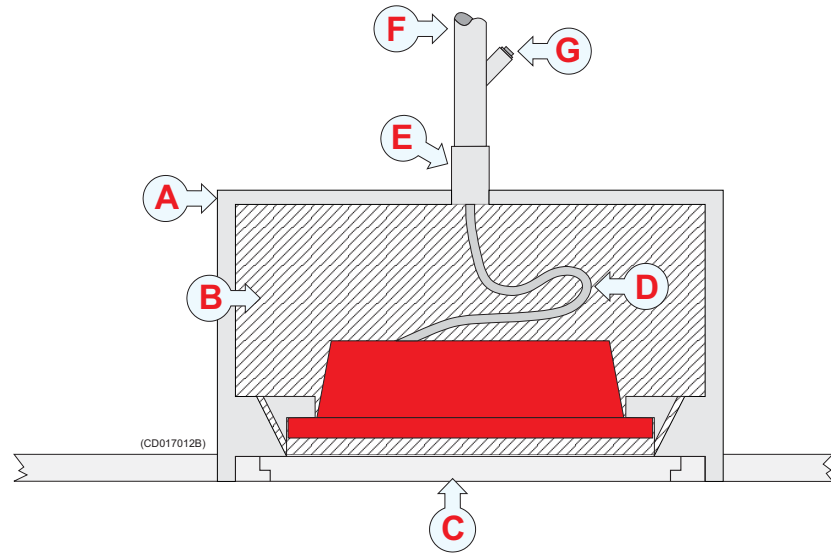

- (A) = Steel tank
- (B) = Oil
- (C) = Acoustic window
- (D) = Cable service loop
- (E) = Stuffing tube
- (F) = Cable in steel conduit
- (G) = Oil inlet

Inside the hull

The transducer can also be mounted inside the hull.

An installation of the transducer inside the hull, and sounding through the hull, requires a good acoustic contact between the transducer face and the hull. Build a tank around the transducer and fill it with a liquid. Oil used in hydraulic systems is a well suited liquid for this purpose. It contains no gas bubbles and is non-corrosive.

Typical values of the two way loss are 3 dB for polyester, 6 dB for aluminium and 10 dB for steel. Hulls made of wood or a sandwich type with foam in the middle, attenuate the sound so much that through hull sounding must be regarded as impossible. The loss varies with the distance between transducer face and the hull. The best result is obtained when the distance is half a wavelength. Consult Simrad for advice. In addition to the loss, the beam pattern is degraded, because a larger area of the hull is set into vibrations.

Mounting and clamping rings

Circular transducers may be provided with mounting and clamping rings, or with drawings to allow for local production of these. The mounting ring is welded to the hole inside the steel tank, while the clamping ring fits around the edge of the transducer body. Bolts through the clamping ring into the mounting ring will then secure the transducer between them. Note that several transducers use direction guides to allow correct mounting.

Smooth surface

Mounting screws or bolts must not be extruding from the acoustic window. Ensure that the surface of the window, the hull plating and putty around the transducer is as even and smooth as possible. Obstructions on these surfaces will create problems with turbulent flow.

Horizontal support bar

Large diameter transducers must be fitted with a horizontal support bar. This bar can be secured to the mounting ring using threaded rods.

Example

The transducer shown in the figure below is mounted inside the hull. The tank is filled with oil.

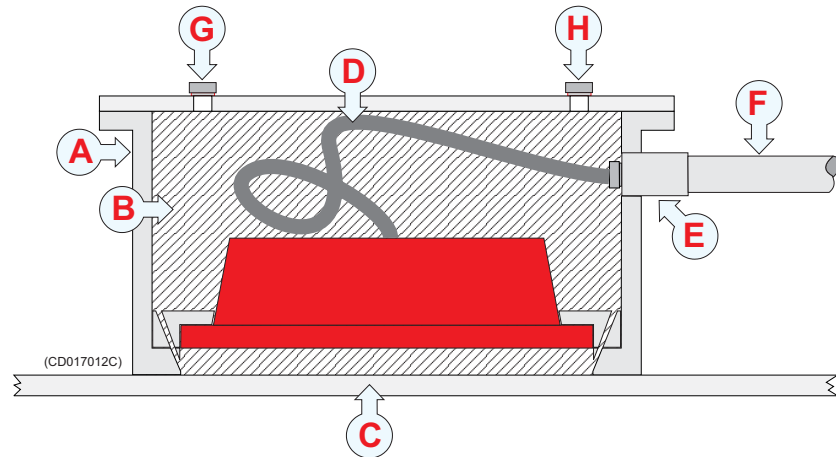

- (A) = *Steel tank*
- (B) = *Oil*
- (C) = *Hull plating*
- (D) = *Cable service loop*
- (E) = *Stuffing tube*
- (F) = *Cable in steel conduit*
- (G) = *Hole for oil filling*
- (H) = *Air outlet*

Drop keel

The use of a drop keel with the purpose of stabilising the vessel is well known.

A drop keel is also a superior platform for echo sounder transducers. Such instrument keels have been built, mainly on research vessels, often protruding as far as three meters below the hull. At that depth, the water is free of air bubbles up to very high sea states. The vessel is then able to perform reliable acoustic measurements in open sea a larger part of the year.

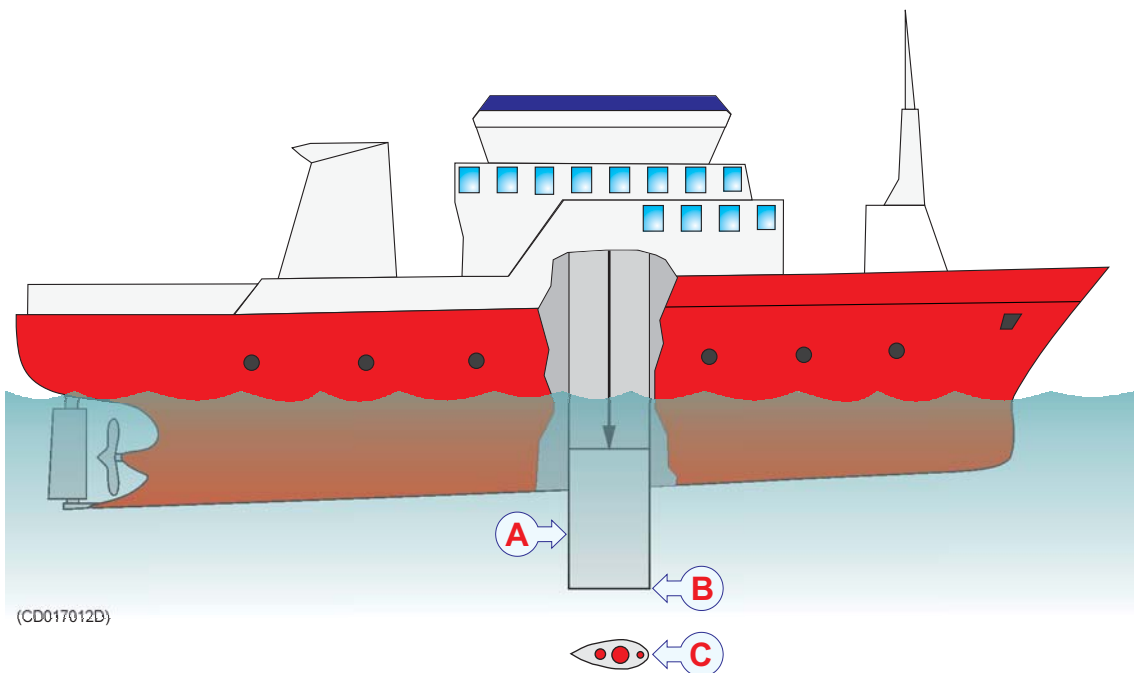

- (A) = *Instrument keel shaft*
- (B) = *Lowered position*
- (C) = *Bottom view*

Retractable transducer

Hull units allowing the transducer to be lowered and hoisted are commonly used for horizontal looking sonars. When not in use, the transducer is retracted into a trunk.

The retractable hull unit is more expensive than a blister, but on vessels with a hull where it is difficult or impossible to install a blister, it may still be worth while. The principles of a hull unit with a retractable transducer is shown below.

Vessels without a keel and with a wide, flat bottom is an example where a retractable hull unit can be the only acceptable method for bringing the echo sounder transducer below the boundary layer.

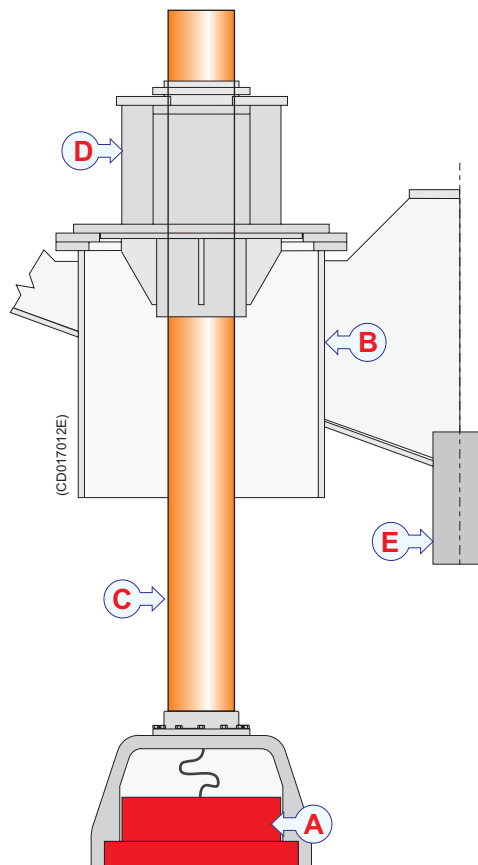

- (A) = Transducer
- (B) = Trunk
- (C) = Transducer shaft
- (D) = Transducer shaft sleeve
- (E) = Keel

CABLE GLANDS

The transducer cable must pass through the hull using approved cable glands for the type of vessel in question.

A **steel** cable gland is normally used on professional vessels with steel hulls. A **bronze** cable gland can be delivered as an option for vessels with wood or fibreglass hulls. Vessel not to be classified can as an option use a cable gland made of **plastic**.

Note _____

Simrad strongly recommends that a length of conduit is fitted around transducer cable glands made of steel or bronze and extended over the water-line inside the vessel. This precaution reduces the danger of flooding in the event of gland failure and transducers installed in this manner are also easier to replace.

Some vessels may experience difficulties finding suitable areas of the hull for mounting transducer cable glands due to existing water tanks, concrete ballast or other obstacles. A possible solution in such cases is to run the transducer cables in a steel conduit aft along the hull until a suitable cable gland location is available. The respective cable gland can then be installed as described in the following instructions.

Note _____

Simrad takes no responsibility for the correct installation of cable glands, associated hull modifications and/or structural support of transducer cable penetration. These activities are subject to individual approval by the respective classification society for the vessel in question.

Order numbers

The cable glands described in this chapter are available as kits from Simrad. Observe the following order numbers.

Steel hull cable gland kit (steel): 599-202216

Wood/GRP hull cable gland kit (bronze): 119-038200

Small hull cable gland kit (plastic): 599-202182

Cable gland for steel hulls

This cable gland kit is designed for steel vessels. It must be welded to the hull plates.

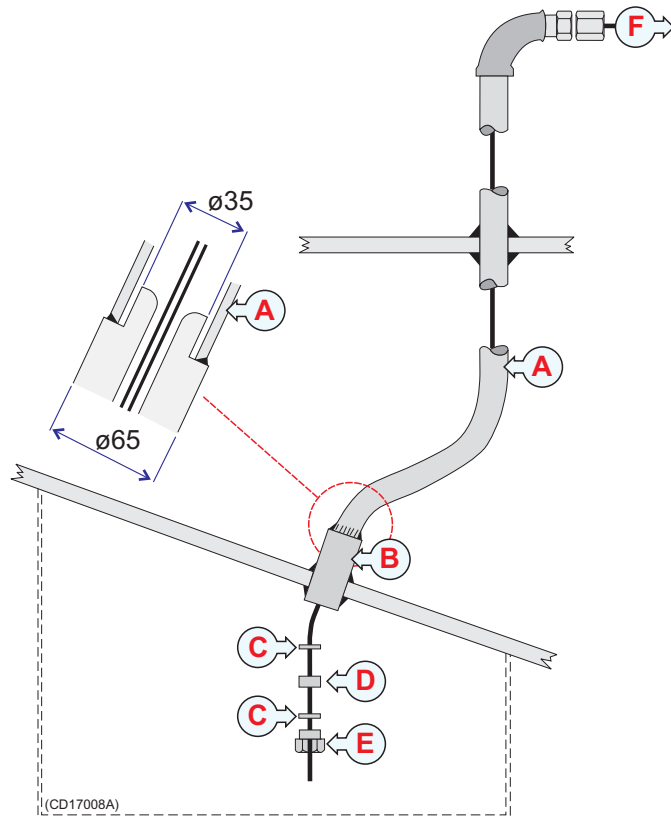

(A) = Steel conduit

(B) = Stuffing tube, DNV approved carbon steel st52.3

(C) = Washers, 24 x 8 x 2 mm

(D) = Rubber gasket

(E) = Packing nipple. Make sure that you do not damage the transducer cable by tightening the packing nipple too hard!

(F) = Cable to the echo sounder (or a junction box)

The cable gland kit includes all of the necessary parts needed to install the unit except screws.

Simrad recommends that a one inch steel conduit (that the transducer cable will be run through) with an inside threaded diameter of three-quarter inches is welded to the gland's stuffing tube. The conduit must extend to above the vessel's water line.

Cable gland for wood or GRP hulls

A bronze cable gland kit is available for wood and GRP vessels.

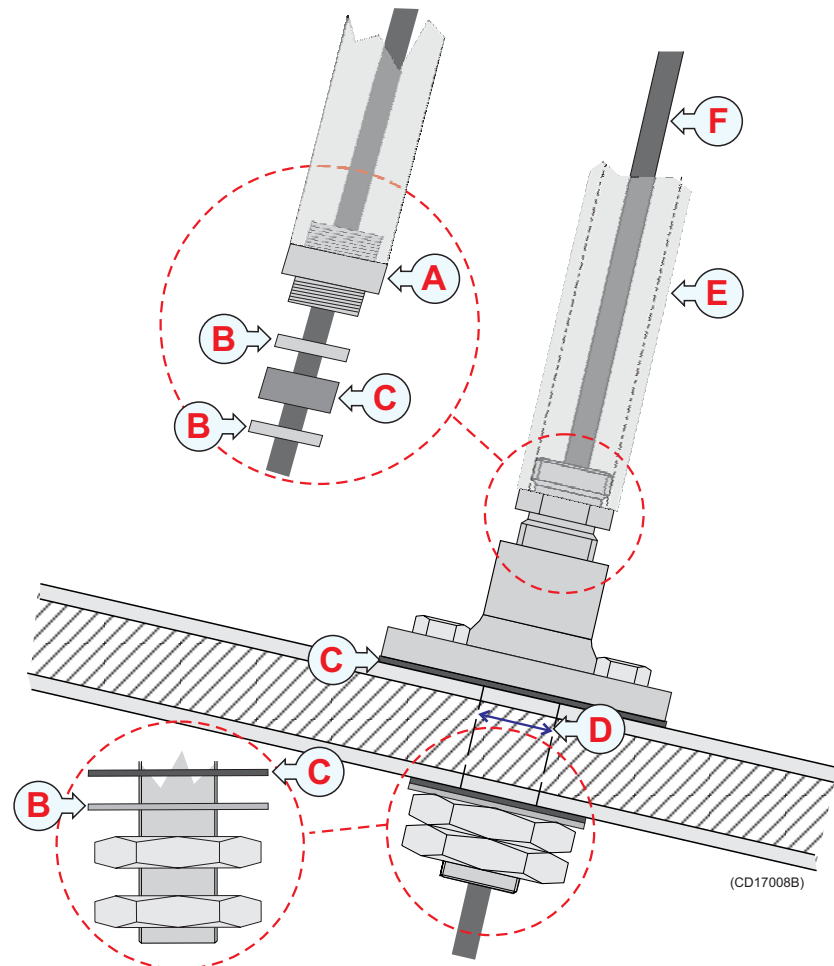

(A) = Packing nipple. Make sure that you do not damage the transducer cable by tightening the packing nipple too hard!

(B) = Washers

(C) = Rubber gaskets

(D) = Hole diameter 28 mm

(E) = Steel conduit

(F) = Cable to the echo sounder (or a junction box)

The cable gland kit includes all of the necessary parts needed to install the unit except screws.

Simrad recommends that a one inch steel conduit (that the transducer cable will be run through) with an inside threaded diameter of three-quarter inches is attached to the gland's packing nipple. This connection must be watertight, and the conduit must extend to above the vessel's water line.

Cable glands for small hulls

This cable glands made of plastic is designed for those smaller vessels that do not need to be classified.

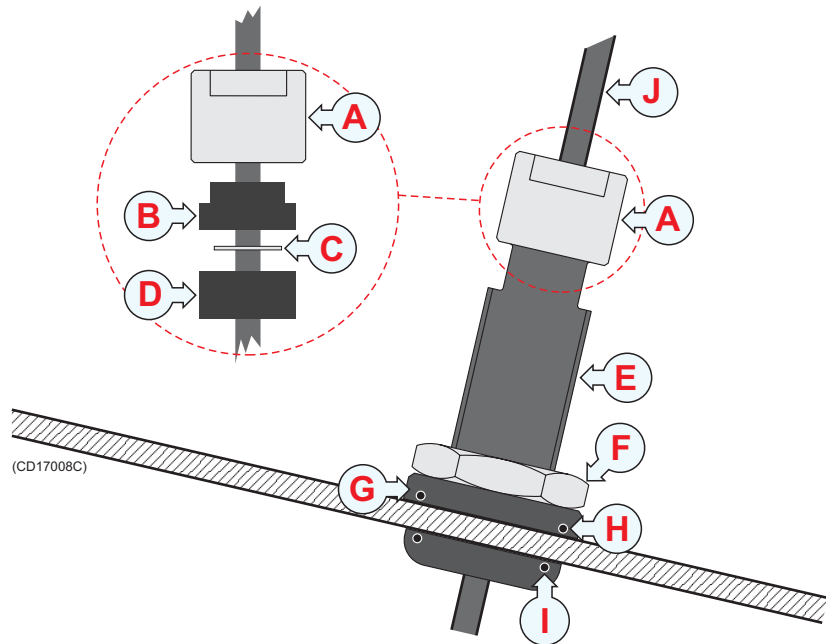

(A) = Packing nut (bronze). Ensure that you do not to damage the transducer cable by tightening the packing nut too hard!

(B) = Rubber gasket

(C) = Plastic disk

(D) = Rubber gasket

(E) = Stuffing tube

(F) = Backing nut (bronze)

(G) = Backing washer (plastic)

(H) = O-ring 42.5 x 3.0 N

(I) = O-ring 39.5 x 3.0 N

(J) = Cable to the echo sounder (or a junction box)

Stuffing tube hole diameter: 36 mm ±1.5 mm.

Apply ample amount of sealant between the backing washer (H) and the hull plate.

The cable gland kit contains all the listed parts, except the sealant.

Note _____

The two O-rings must be clean, in good condition and free of cuts or other defects which could affect their watertight integrity.

Cable splicing

If you need to cut the transducer cable, you must splice it correctly.

Note _____

DO NOT solder the wires together with only electrical tape for insulation, as this will result in electrical noise and reduced operational performance.

To splice the cable, use a metal junction box. The chassis of the junction box must be grounded, but the cable shielding must NOT be connected to the junction box ground.

STEEL CONDUIT

It is strongly recommended to lay a steel conduit from the transducer's cable gland to the echo sounder transceiver, and to pull the transducer cable through this conduit. There are two reasons for this.

- First, it will make it easier at a later stage to replace the transducer.
- Second, noise and interference from other electrical equipment is greatly reduced.

With a steel conduit the installation will satisfy the EU regulations for EMC interference. Without a steel conduit, there is a risk of reduced echo sounder performance.

The steel conduit must be unbroken and watertight from the transducer to above the water line. From there, the cable can be pulled further, or a junction box can be installed to facilitate further connections. Note that the steel conduit must act as a continuous electrical screen all the way. To ensure proper shielding, the conduit must be electrically connected to the echo sounder transceiver chassis.

Steel conduit dimensions:

- minimum 35 mm inner diameter
- minimum 6 mm wall thickness (4.5 mm if galvanised)

If two or more transducers are installed close to each other it is possible to pull their cables in the same steel conduit, provided the conduit diameter is increased accordingly. However, for easy replacement it is recommended that each transducer has its own steel conduit.

HANDLING AND MAINTENANCE

Do not lift the transducer by the cable.

Some transducers are delivered with a cover plate on the face for protection during transport. Let this plate stay on as long as possible, but do not forget to remove it before the vessel goes into the sea.

An anti-fouling paint may be applied to the transducer face. Because some paint types may be aggressive to the polyurethane in the transducer face, please consult Simrad's list of approved paints.

Note

Arctic tanks have acoustic windows made of polycarbonate. These must neither be painted nor cleaned with chemicals.

During dry docking of the vessel, the transducer face may be cleaned for shells and other marine fouling. Be careful not to make cuts in the transducer face. Use a piece of wood or a very fine grade emery paper.

Approved anti-fouling paints

This is Simrad's list of approved antifouling paints on polyurethane transducer housing.

Jotun

Head office address: P.O.Box 2021, N-3248 Sandefjord, Norway

Website: www.jotun.com.

- 1 Racing
- 2 Non-stop
- 3 Safeguard Universal primer (125 micron)
- 4 Antifouling SeaQuantum Ultra (125 micron)
- 5 Antifouling Seaguardian

International Marine Coatings

Address: World-wide offices

Website: www.international-marine.com.

- 1 Intersleek tie coat + 425 FCS
 - BXA386/BXA390/BXA391 Grey
 - HKA563/HKA570/HKA571 Yellow
 - Mix BXA386, BXA390 and BXA391 first, then apply. When dry, mix HKA563, HKA570 and HKA571, apply.
- 2 Intersmooth 360 Ecoloflex SPC
- 3 Micron Ekstra

Hempel IFA Coatings

Head office address: Hempel A/S, Lundtoftevej 150, Kgs. Lyngby, DK-2800 Copenhagen, Denmark

Website: www.hempel.com.

- 1 Hempel A/F Classic 76550

Note _____

Refer to the manufacturer's documentation and data sheets for a complete procedure.

DRAWING FILE

This chapter contains relevant drawings related to the electrical and physical installation of the 50-7 Single beam transducer.

Note _____

The mechanical drawings are for information and guidance only. They are not in scale. All dimensions are in mm unless otherwise is noted.

Observe the maximum torque (31 Nm) when the transducer is bolted into the mounting ring!

The original installation drawings are available on PDF and AutoCad format. Visit www.simrad.com to download.

In addition to the drawings available in this chapter, an additional drawing is provided on the web site. This is drawing 599–203664 describing an optional steel tank for the transducer.

Drawings

Single frequency, single beam, low power transducer connection on page 36

Outline dimensions on page 37

Mounting arrangement on page 38

Mounting ring on page 40

Blister assembly on page 42

Blister design on page 44

Single frequency, single beam, low power transducer connection

This is the termination of the transducer cable from a single frequency, single beam transducer to the transducer socket on the General Purpose Transceiver Unit (GPT). The other end of the cable is permanently fixed to the transducer.

All transducer cables must be run in steel conduits. Use a flexible conduit closer to the transceiver.

Low power output is achieved when the GPT is equipped with a single transmitter board. In most systems, this will result in a 2 kW output power, but older GPTs may only be capable of supplying 1 kW.

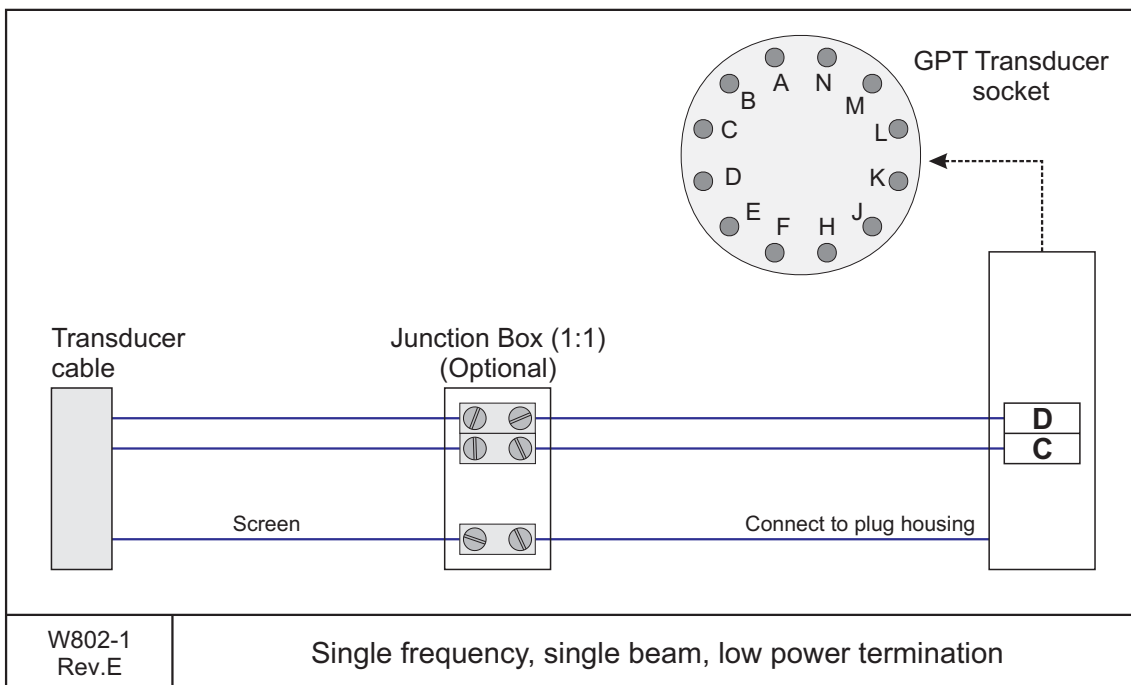

Note

The cable screen must not be connected to the ship's ground through the junction box.

The cable screen can be connected to the junction box chassis, but the junction box chassis must not be connected to ship's ground.

Outline dimensions

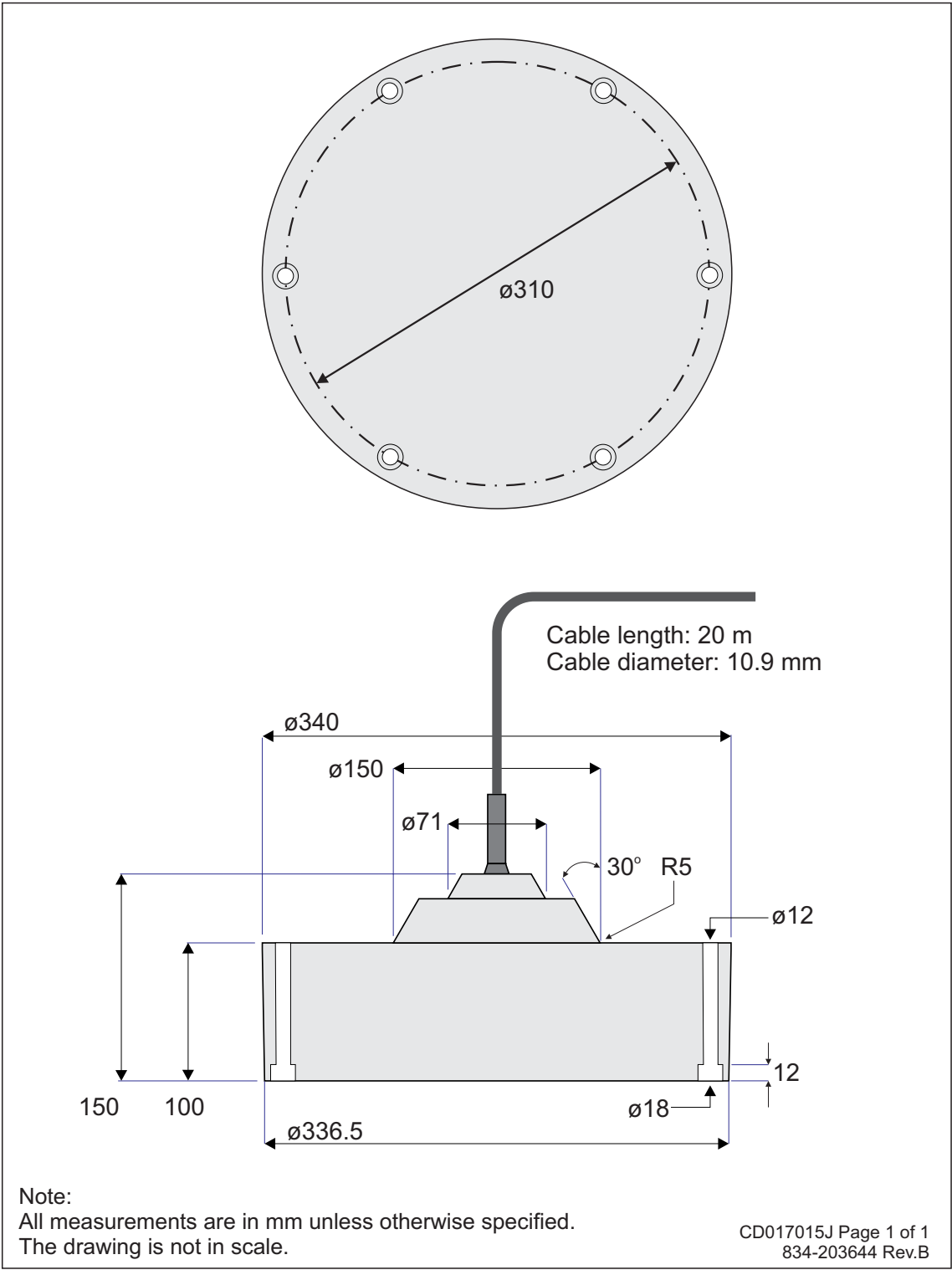

Mounting arrangement

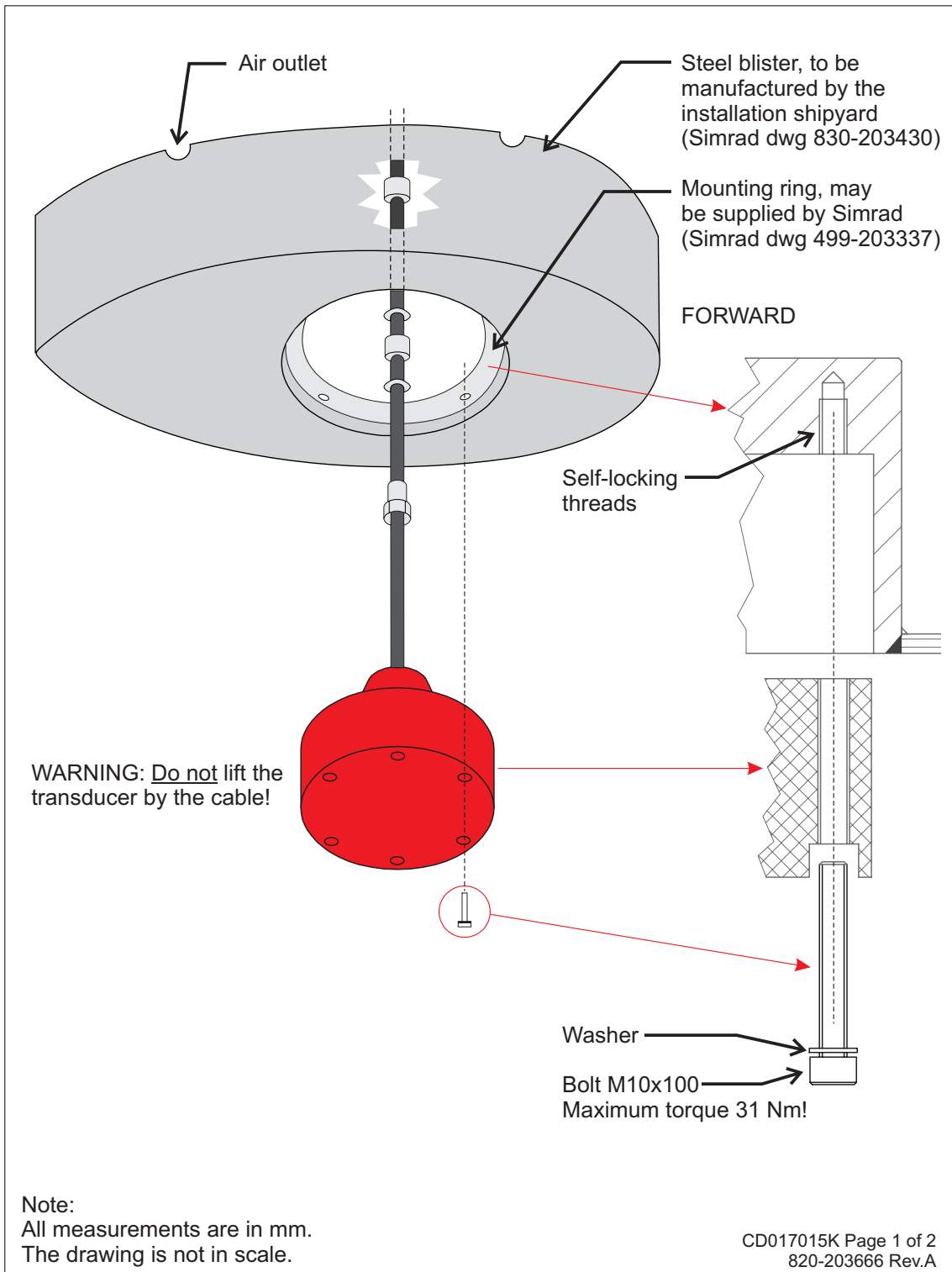

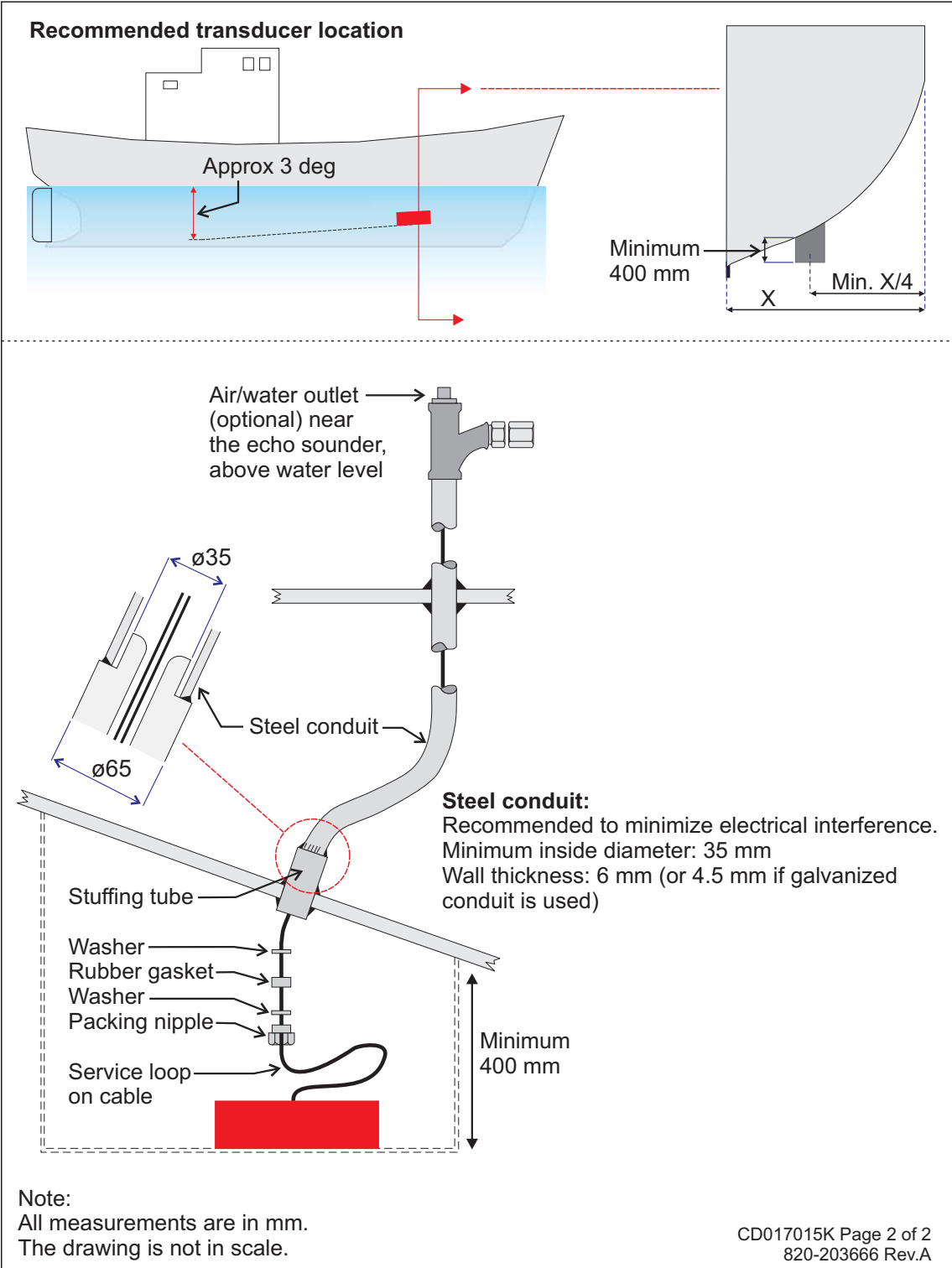

Mounting ring

Surface treatment:

- 1) Sand blast to SA 2.5
- 2) One coating of red ferric oxide primer

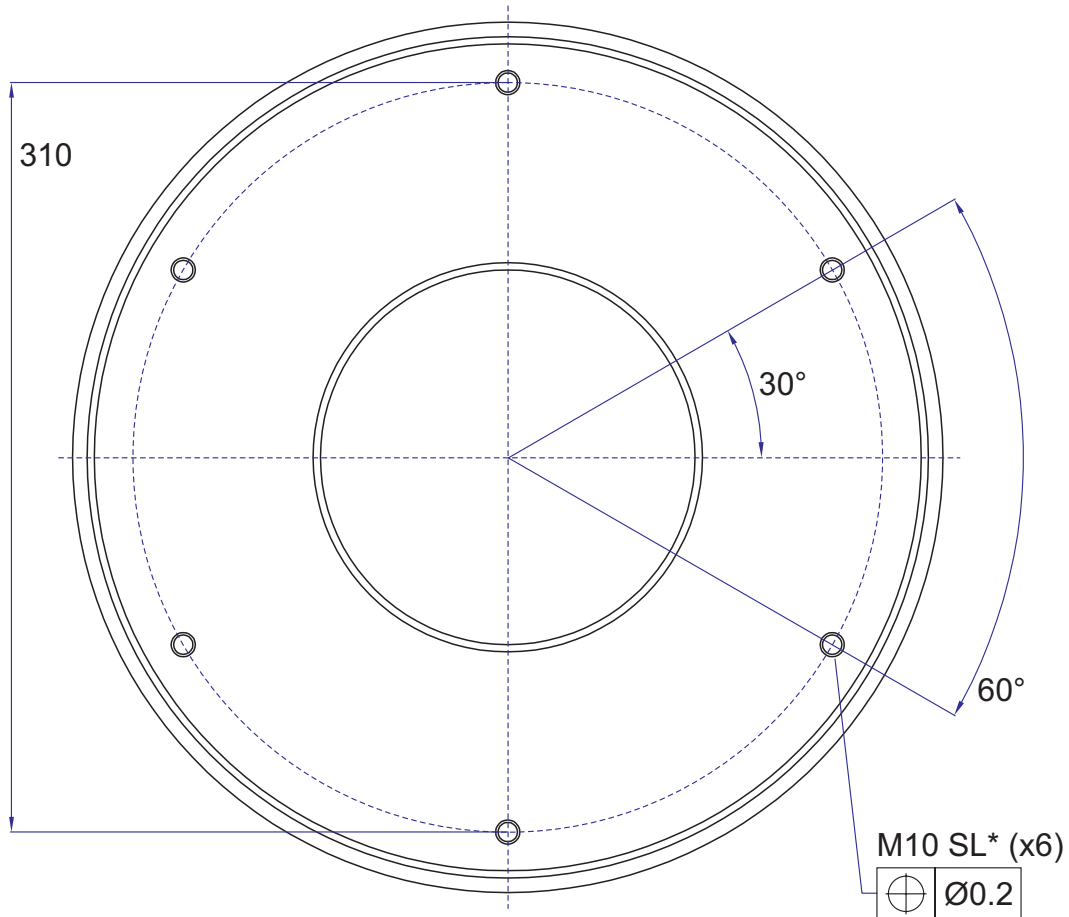

The self-lock threads (SL*) must be made in accordance with Simrad procedure 842-202125. Self-lock taps can be supplied by Simrad.

Note:
All measurements are in mm.
The drawing is not in scale.

CD017015G Page 1 of 2
871-203337 Rev.B

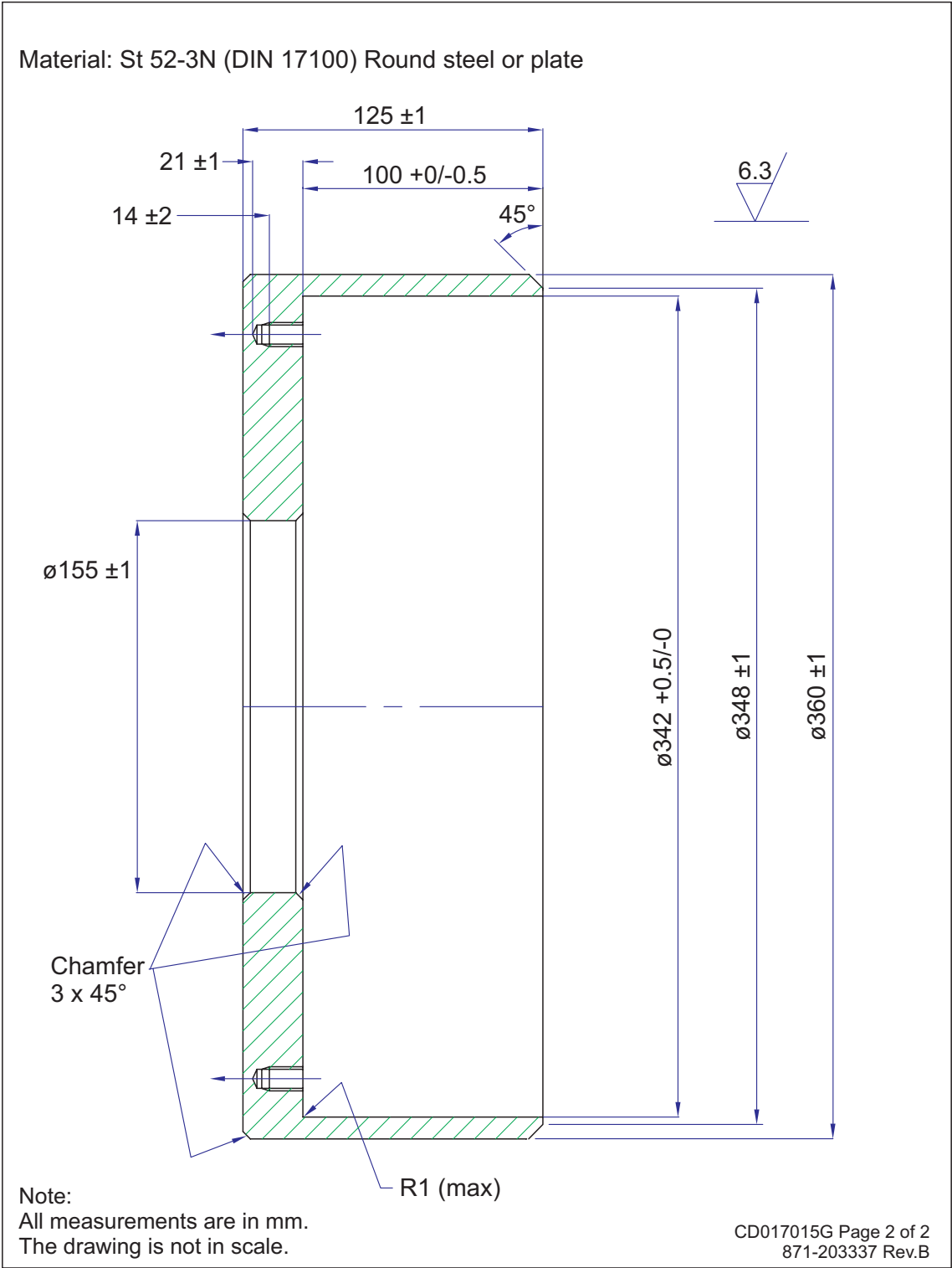

Blister assembly

Surface treatment:

To avoid acoustic noise, it is very important that the surface of the blister is smooth. Avoid cracks, dents and other unevenness.

- 1) Sand blast after grinding to SA 2.5
- 2) Apply one coat of red ferric oxide prime
- 3) No concavity is accepted
- 4) Maximum convexity is 3 mm
- 5) Small local hollows (max 1 mm!) can be accepted

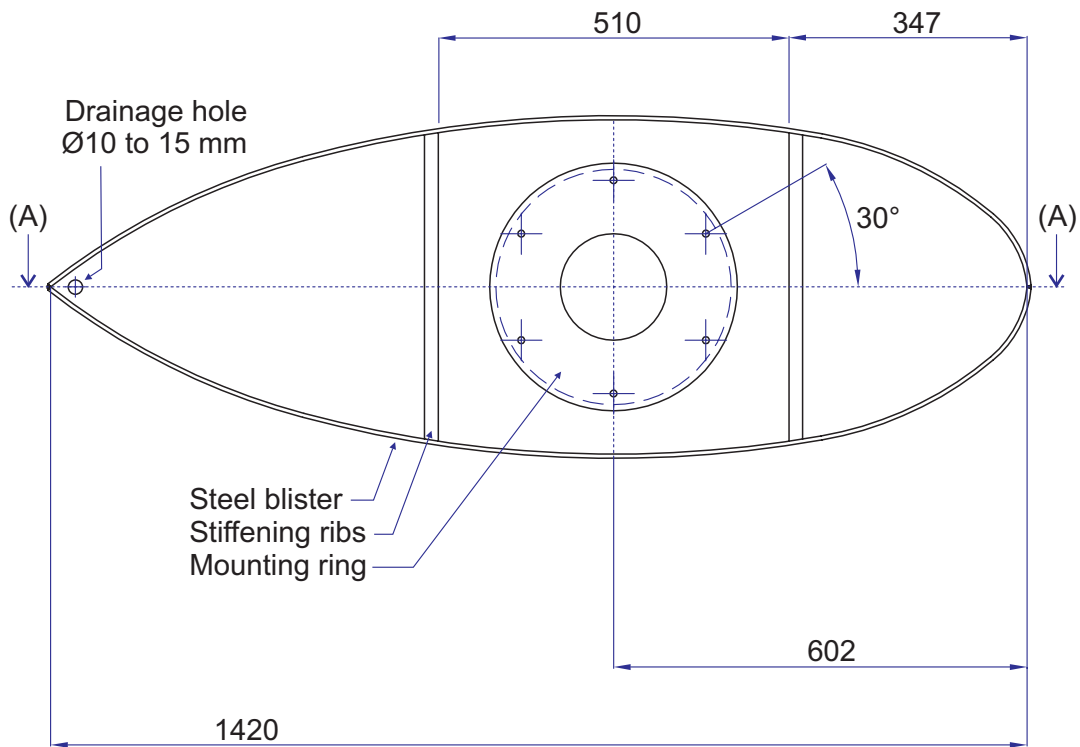

Note:
All measurements are in mm.
The drawing is not in scale.

CD017015H Page 1 of 2
830-203430 Rev.B

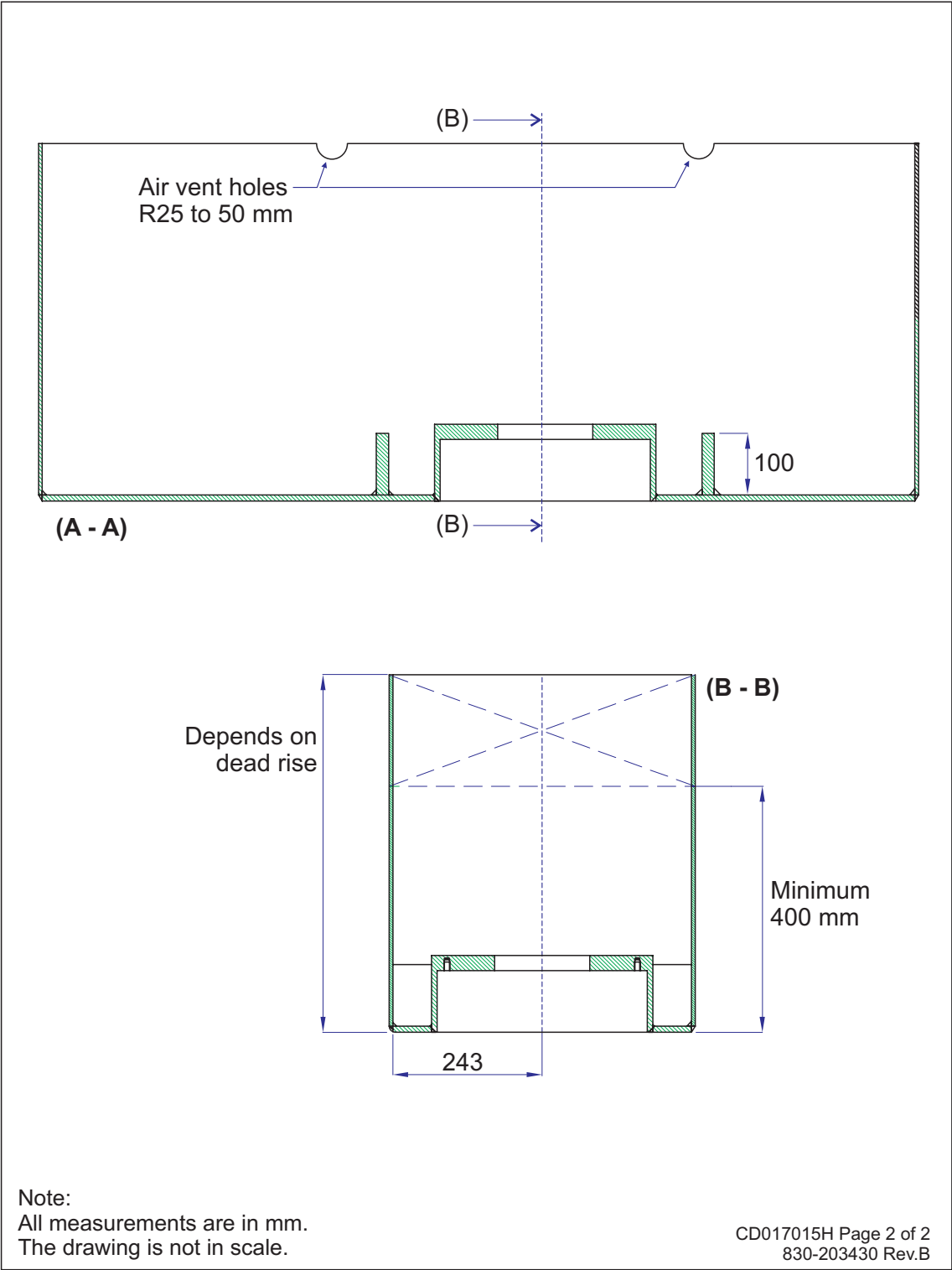

Blister design

Bottom plate must be smooth and even!

- 1) No concavity is accepted
- 2) Maximum convexity is 3 mm
- 3) Small local hollows (max 1 mm!) can be accepted

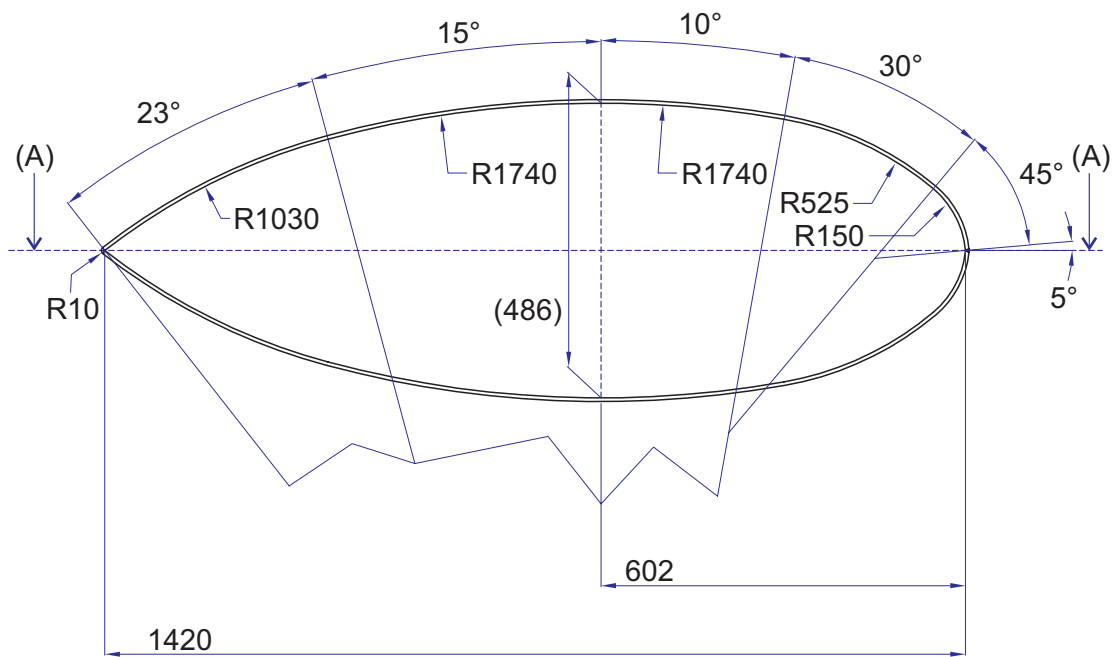

Note:
All measurements are in mm.
The drawing is not in scale.

CD0170151 Page 1 of 2
871-203432 Rev.A

Materials: Steel plate, Fe 510 D1 (St 52-3 N), 6 and 10 mm

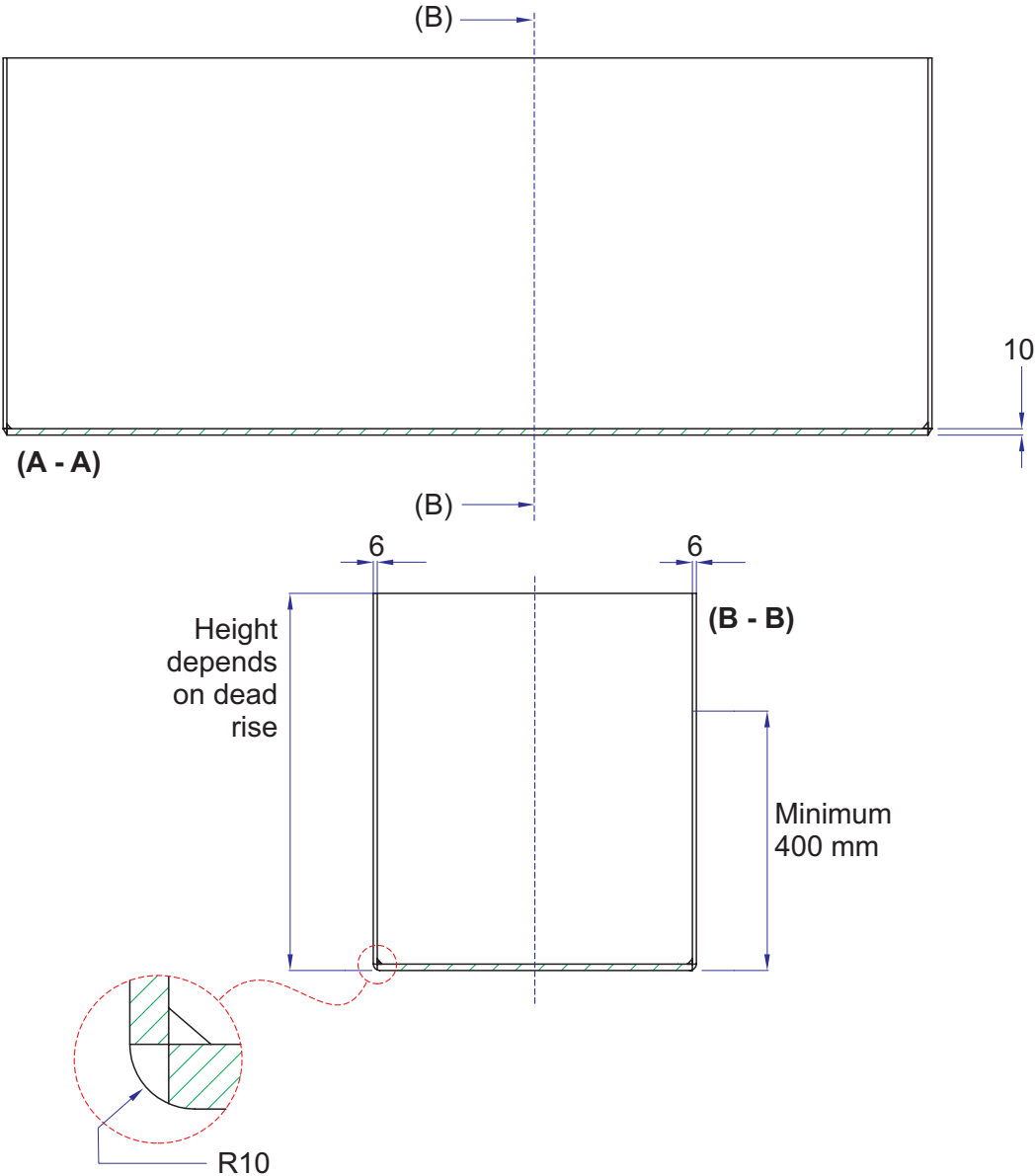

Note:
All measurements are in mm.
The drawing is not in scale.

A

Acoustic window
 installation, 21
 Air bubbles, 6
 Anti-fouling
 paint, 34
 Arctic tank
 cleaning, 33
 painting, 33
 polycarbonate, 33

B

Blister
 installation, 11
 Blister assembly
 drawing, 42
 Blister design
 drawing, 44
 Boundary
 water layer, 7
 Bow thrusters
 noise, 8
 Box keel
 installation, 17

C

Cable
 Single beam transducer, 36
 splicing, 31
 Cable gland
 GRP hull, 29
 small hull, 30
 steel hull, 28
 Cavitation, 6
 Clamping ring
 acoustic window, 21
 blister, 11
 box keel, 17
 flush mounting, 19
 inside hull, 23
 Conduit, 32
 Connection
 single beam transducer, 36

D

Depth, 6
 Drawing
 Blister assembly, 42
 Blister design, 44
 Mounting arrangement, 38
 Mounting ring, 40
 Outline dimensions, 37
 Drawing file, 35

E

EMC interference, 32

F

Flush mounting
 flush mounting, 19

G

GPT Connection
 single beam transducer, 36
 GRP hull
 cable gland, 29

H

Handling, 33
 Heave
 vessel, 6

I

Inclination
 angle, 8
 Installation
 drawings, 35

L

Layer
 boundary, 7
 Location
 recommendation, 8
 transducer, 6

M

Maintenance, 33
 Mounting arrangement
 drawing, 38
 Mounting ring
 acoustic window, 21
 blister, 11
 box keel, 17
 drawing, 40
 flush mounting, 19
 inside hull, 23

N

Noise
 air bubbles, 6
 bow thrusters, 8
 cavitation, 6
 propeller, 7

protruding objects, 6

O

Outline dimensions
 drawing, 37

P

Paint
 anti-fouling, 34
 Propeller
 noise, 7
 Protruding objects, 6

S

Single beam transducer
 connection, 36
 Splicing
 cable, 31
 Steel conduit, 32
 Steel hull
 cable gland, 28
 Steel tank
 flush mounting, 19
 Support bar
 acoustic window, 21
 blister, 11
 box keel, 17
 flush mounting, 19
 inside hull, 23
 Surface
 acoustic window, 21
 blister, 11
 box keel, 17
 flush mounting, 19
 inside hull, 23

T

Transducer
 depth, 6
 location, 6
 recommended location, 8
 Transducer cable
 splicing, 31

V

Vessel
 heave, 6

W

Water filled
 flush mounting, 19

ISBN-10: 82-8066-075-5
ISBN-13: 978-82-8066-075-6
©2006 Simrad

Simrad Horten AS

Strandpromenaden 50
P.O.Box 111
N-3191 Horten,
Norway

Telephone: +47 33 03 40 00
Telefax: +47 33 04 29 87
www.simrad.com
simrad.sales@simrad.com

SIMRAD
A KONGSBERG Company