

Installation manual

Simrad ES70 Fish finding echo sounder

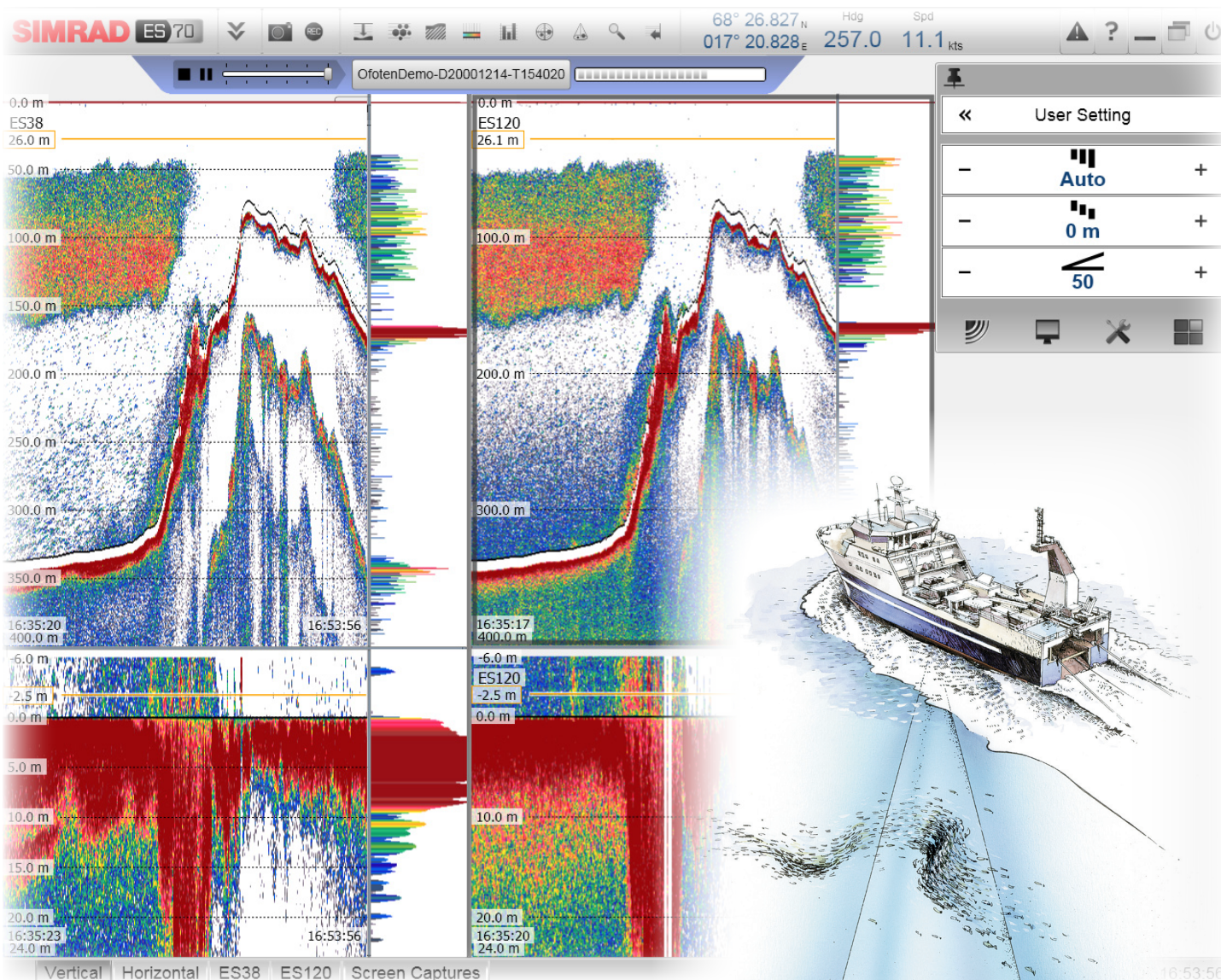



KONGSBERG

Simrad ES70

Installation manual

This manual provides you with the basic information required to install the Simrad ES70 Fish finding echo sounder. For more detailed information about the practical use of the product, refer to the *Simrad ES70 Operator manual* or the *Simrad ES70 Reference manual*.

The following hardware components are described:

- Display
- Keyboard
- General Purpose Transceiver (GPT)
- Standard echo sounder transducer(s)
- Split beam echo sounder transducer(s)
- ES70 Computer (or commercial type)

343522/A

3 February 2010 © Kongsberg Maritime AS

Document history

Document number: 343522 / Rev. A / ISBN-13: 978-82-8066-117-3		
Rev.A	03.02.2010	First version.

Copyright

©2010 Kongsberg Maritime AS

The information contained in this document remains the sole property of Kongsberg Maritime AS. No part of this document may be copied or reproduced in any form or by any means, and the information contained within it is not to be communicated to a third party, without the prior written consent of Kongsberg Maritime AS. The document, or any part of it, may not be translated to any other language without the written approval from Kongsberg Maritime AS.

Disclaimer

Kongsberg Maritime AS endeavours to ensure that all information in this document is correct and fairly stated, but does not accept liability for any errors or omissions.

Warning

The equipment to which this manual applies must only be used for the purpose for which it was designed. Improper use or maintenance may cause damage to the equipment and/or injury to personnel. The user must be familiar with the contents of the appropriate manuals before attempting to install, operate or work on the equipment.

Kongsberg Maritime AS disclaims any responsibility for damage or injury caused by improper installation, use or maintenance of the equipment.

Support information

If you require maintenance or repair, contact your local dealer. You can also contact us using the following address: simrad.support@simrad.com. If you need information about our other products, visit our web site. On the web site you will also find a list of our dealers and distributors.

Table of contents

ABOUT THIS MANUAL	9
SIMRAD ES70	10
Important	10
System overview	11
Key facts	11
Main units	12
Simplified system diagrams	13
General supply conditions	14
Equipment responsibility	14
Receipt, unpacking and storage	15
General installation requirements	15
Approval by classification society	15
Supply power	15
Compass deviation	15
Noise sources	16
Dry docking	16
Wiring	16
INSTALLATION PROCEDURES	17
Basic procedure	17
Configuration	18
Echo sounder transducer	19
Split-beam echo sounder transducers	19
General Purpose Transceiver (GPT)	19
ES70 Marine Computer	21
Colour display	22
Software	22
Printer	22
General Purpose Transceiver (GPT) installation	22
ES70 Marine Computer installation	24
Colour display	24
ES70 CABLE LAYOUT	26
Cable plan	27
Basic cable plans provided	27
ES70 Cable plan	28
List of cables	31
Connector identifications	35
GPT connections	35
Transducer connections	37

Cable drawings	40
Generic RS-232 Serial line	41
Generic RS-232 Serial line	42
RS-232 as external trigger	43
Sonar synchronisation	44
Commercial power supply	45
Vessel ground	46
GPT external power	47
AC mains (IEC 60320).....	48
RJ45 Ethernet, straight	49
RJ45 Ethernet, crossover.....	50
VGA/SVGA Display.....	51
USB.....	52
Parallel printer.....	53
DVI-I Display.....	54
Serial line adapter	55
GPT remote on/off	56
GPT trigger / synchronisation	58
GPT battery	59
ITI serial line	60
PI44/54 serial line	61
PI30/32 serial line.....	62
Sonar serial line	63
Single beam/normal power transducer	64
Single beam/high power transducer.....	65
Dual beam (wide or narrow) transducer	66
Split beam transducer	67
Split beam transducer to single beam transceiver	68
Dual frequency, single beam transducer	69
ES38-10 transducer	70
Single beam transducer to split beam transceiver	71
12-16/60 transducer	72
Deep water, split beam transducer	73
50/200 Combi C transducer	74
38/200 Combi C transducer	75
SOFTWARE INSTALLATION	76
How to install the ES70 software.....	76
How to obtain the ES70 license	77
How to upgrade the ES70 software.....	77
How to remove the ES70 software.....	78
CONNECTING THE TRANSCIEVER	79
General Purpose Transceiver (GPT) interface.....	79

Wiring procedure, one transceiver	79
Wiring procedure, two or more transceivers	79
Setup procedure	80
Administration of frequency channels	80
How to install a frequency channel	81
How to disconnect a frequency channel	81
How to modify an IP address	82
INTERFACES AND INTEGRATION	84
About NMEA interfaces and telegrams	84
NMEA	85
Telegrams	85
Standard NMEA 0183 communication parameters	85
External interfaces	85
How to set up the Ethernet output interface	86
How to set up the Simrad ITI Trawl system interface	87
How to set up the Simrad PI Catch monitoring system interface	88
How to set up the sonar system interface	90
How to set up the navigation system interface	90
How to set up the motion sensor interface	92
How to set up the depth output	93
How to set up the annotation interface	94
ES70 External triggering	95
Synchronisation using a serial line	95
Synchronisation using GPT Auxiliary plug	96
GPT Auxiliary plug schematics	97
GPT Auxiliary connector	99
DRAWING FILE	101
GPT Outline dimensions	102
Page 1	102
Page 2	103
GPT Power supply outline dimensions	104
Page 1	104
Page 2	105
Marine computer outline dimensions	106
GPT Transducer plug connection	107
TECHNICAL SPECIFICATIONS	108
Echo sounder specifications	108
Interface specifications	109
General Purpose Transceiver (GPT) specifications	109
Colour display specifications	111
ES70 Marine Computer specifications	111

TRANSDUCER INSTALLATION	113
Where to mount the transducer	113
How to install the transducer	117
External mounting of streamlined transducer	118
Transducer installation in blister	121
Transducer installation in box keel	127
Transducer flush mounted in a steel tank	128
Transducer with acoustic window	130
Transducer mounted inside the hull	131
Transducer mounted on a drop keel	133
Retractable transducer	134
Towed body installation	134
Transducer cable glands and splicing	137
About cable glands	138
Cable gland for steel hulls	139
Cable gland for wooden and GRP hulls	140
Cable glands for small hulls	141
Transducer cable splicing	142
Order numbers	142
Steel conduit	142
Transducer handling and maintenance	143
Rules for transducer handling	143
Rules for transducer maintenance	144
Approved anti-fouling paints for transducers	144
Using self-locking taps	145
SIMRAD TRANSDUCERS	149
All single beam transducers	149
All split-beam transducers	154
TELEGRAM FORMATS	160
NMEA telegrams	160
About the NMEA telegram format	161
DBS Depth below surface	161
DBT Depth below transducer	162
DPT Depth	162
GGA Global positioning system fix data	163
GLL Geographical position latitude/longitude	163
HDG Heading, deviation and variation	164
HDM Heading, magnetic	164
HDT Heading, true	165
RMC Recommended minimum specific GNSS data	165
VHW Water speed and heading	165
VLW Dual ground/water distance	166

VTG Course over ground & ground speed.....	166
Proprietary telegrams and formats	167
Simrad EK500 Depth.....	167
Simrad EM Attitude 1000.....	168
Simrad EM Attitude 3000.....	169
DBS Depth of trawl below surface.....	170
HFB Trawl headrope to footrope and bottom	170
PSIMP.D PI Sensor data.....	171
PSIMDHB Bottom hardness and biomass.....	172
Sounder/TSS1 Motion protocol.....	173
Simrad ATS Annotation	174
Proprietary third party telegrams and formats.....	174
Atlas depth telegram	175
A GENERAL SAFETY RULES.....	176
B EQUIPMENT HANDLING	177
Transportation.....	177
Lifting.....	177
Storage prior to installation or use	178
Inspection	179
Unpacking	179
General unpacking procedure	179
Unpacking electronic and electromechanical units	180
Unpacking mechanical units.....	180
Unpacking transducers	181
Storage after unpacking.....	181
Storage after use	181
Cleaning cabinets.....	182
Mechanical units.....	182
Cables.....	182
Internal batteries	183
Dehumidifier	183
Coatings.....	183
Re-packaging.....	183
Temperature protection.....	183
Circuit board handling and packaging.....	184
Returning a circuit board	185
Electro-Static Discharge (ESD).....	185
C BASIC CABLE REQUIREMENTS	187
Cable trays.....	187
Radio Frequency interference	188
Physical protection	188

Grounding.....	188
Cable connections.....	189
Cable terminations.....	189
Cable identification.....	189

About this manual

The purpose of this manual

The purpose of this installation manual is to provide the descriptions and procedures required to install the Simrad ES70 Fish finding echo sounder system units, and to perform the necessary cabling between the individual system units, and between the system and peripheral systems, sensors and devices.

Click “Help”!

Installed on your Simrad ES70 Fish finding echo sounder you will find a comprehensive on-line help system. You may not find it in your language, but everything you can read in the *ES70 Reference manual* can also be found in the context sensitive on-line help. To access this information click [?] on the **Title Bar**, or the [?] button in one of the dialogs. Note that when you open the help system it will place itself on the top of the echogram!

Note

Windows NT, Windows 2000, Windows XP, Windows Vista, Windows 7 and Windows are either registered trademarks or trademarks of Microsoft Corporation in the United States and/or other countries.

References

The following user manuals have been provided for the Simrad ES70 Fish finding echo sounder. English manuals are provided with the ES70 when it is shipped. Manuals in other languages may be downloaded from www.simrad.com.

- Simrad ES70 Reference manual [338106]
- Simrad ES70 Operator manual [343522]
- Simrad ES70 Installation manual [343539]

Simrad ES70

The purpose of this chapter is to provide an overall description of the ES70 Fish finding echo sounder system and its main features.

Topics

- *Important* on page 10
- *System overview* on page 11
- *General supply conditions* on page 14
- *General installation requirements* on page 15

Related topics

- *General safety rules* on page 176
- *Equipment handling* on page 177
- *Basic cable requirements* on page 187

Important

As with all other advanced instruments, there are a few important things that you must be aware of.

When the echo sounder is not used

When you do not use the ES70, switch off the display and the computer. You may switch of the transceiver too.

When docking your vessel

It is very important that no one tries to use the ES70 when the vessel is in dry dock. If the transducer is activated when out of water it may be damaged beyond repair. To ensure that this can not happen, remove the power supply to the either the computer or the transceiver - or both! You may also remove circuit breakers. Do this before the vessel is placed in the dry dock!

If something breaks down

If you believe that something has broken down, contact your local dealer. He will be able to assist.

When you switch off the echo sounder

You must NEVER switch off the echo sounder by means of the on/off switch on the computer. You must ALWAYS exit the ES70 application by clicking the **Exit** button on the **Title Bar**. If you power down the sounder by means of the computer switch you may damage the ES70 application and the electronic interface parameters for the external devices.

System overview

This section provides the key facts about the ES70 Fish finding echo sounder system, as well as a brief introduction to the main units.

Key facts

The Simrad ES70 Fish finding echo sounder is designed for the professional fishery community implementing the latest innovations. Echo sounders ranging from relatively low-cost single beam to large multi-frequency systems containing several split-beam channels can be realised.

- The Simrad ES70 Fish finding echo sounder system is flexible and easy to set up due to its modular design.
- Menus and dialogs are operated using a standard computer mouse or a trackball.
- Additional user input can be facilitated using a standard computer keyboard.
- The ES70 supports large colour display monitors.
- The ES70 uses the Microsoft Windows® operating system. It complies to Windows XP® and Windows 7®.
- The ES70 provides you with an award winning user interface. Menu system, dialogs and structure have been created using innovative design, and in close cooperation with customers.
- A store/replay function reduces the need for echogram printout on paper. The unprocessed transducer signal is recorded on the internal hard disk. During replay, this signal is injected into the ES70 processing software as if it arrived directly from the transceiver.

Main units

The basic ES70 Fish finding echo sounder consists of:

- Display
- Computer (The ES70 Marine Computer may be provided)
- One or more General Purpose Transceiver (GPT) units
- One or more standard single beam transducers
- One or more split-beam transducers

Colour display

A standard commercial colour display is used. The display unit is normally not provided by Simrad. Several commercial types and sizes are available.

ES70 Marine Computer

Simrad can supply the **ES70 Marine Computer** for the ES70 Fish finding echo sounder system.

Figure 1 ES70 Marine Computer



A commercial computer may also be used. It must comply to the requirement specifications laid out by Microsoft for their operating systems. It must also provide the necessary interface facilities (serial lines and Ethernet connections) that your system will need to communicate with external sensors (measuring devices) and peripheral systems.

→ *ES70 Marine Computer* on page 21

General Purpose Transceiver (GPT)

The General Purpose Transceiver (GPT) contains transmitter and receiver electronics. The receivers are designed for low noise, and they can handle input signals spanning a very large instantaneous dynamic amplitude range of 150 dB. All targets are correctly measured and displayed.

Figure 2 General Purpose Transceiver (GPT)



A twisted pair Ethernet cable connects the General Purpose Transceiver (GPT) to the computer. The distance between the computer and the General Purpose Transceiver can be extended up to maximum 100 meters.

If more than one transceiver is used, a small Ethernet switch is required to connect the General Purpose Transceivers to the computer.

Standard single beam transducer

The ES70 must be connected to one or more transducers.

A wide range of operational frequencies are available.

For more information about the single beam transducers provided by Simrad, consult www.simrad.com.

Split-beam transducer

The ES70 can be used with Simrad’s advanced split-beam transducers. These transducers are available at frequencies ranging from 18 to 200 kHz.

For more information about the split-beam transducers provided by Simrad, consult www.simrad.com.

Simplified system diagrams

The system diagrams provided show examples on how a ES70 system may be set up.

Figure 3 System diagram with a single General Purpose Transceiver

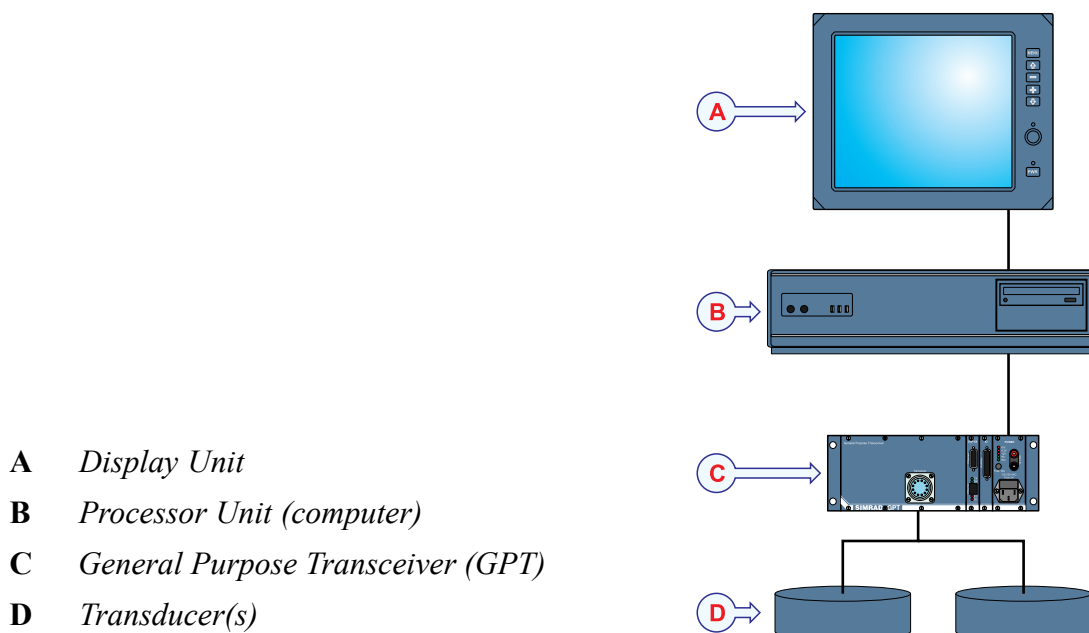

- A Display Unit
- B Processor Unit (computer)
- C General Purpose Transceiver (GPT)
- D Transducer(s)

Figure 4 System diagram with two General Purpose Transceivers

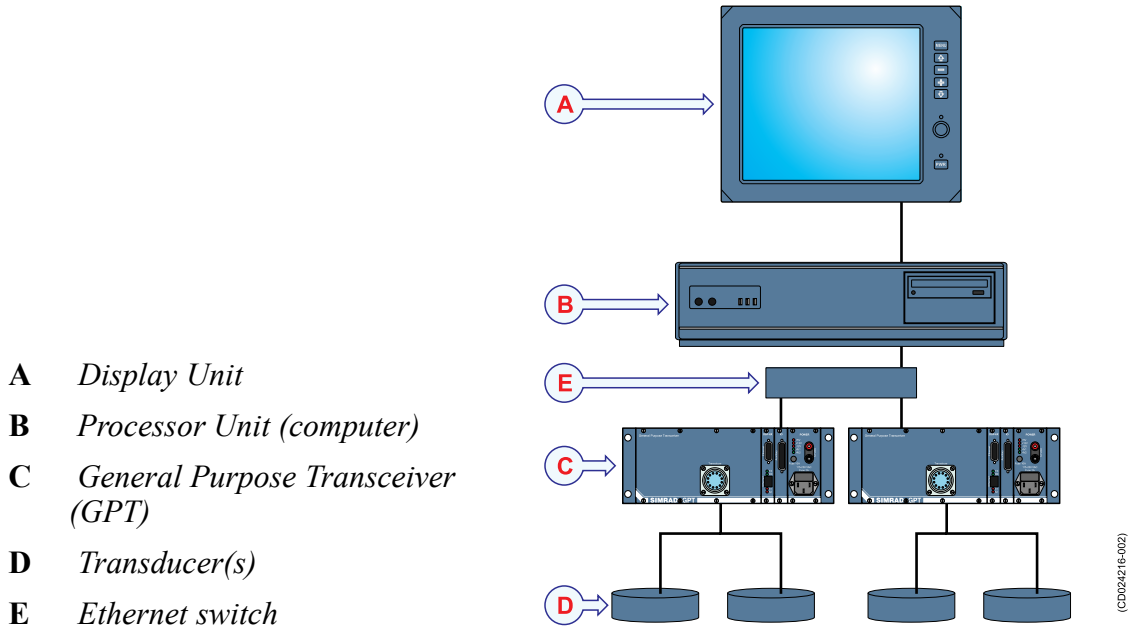

- A Display Unit
- B Processor Unit (computer)
- C General Purpose Transceiver (GPT)
- D Transducer(s)
- E Ethernet switch

General supply conditions

The following supply conditions are applicable to this Simrad ES70 delivery.

Equipment responsibility

The shipyard performing the installation and/or equipment dealer becomes fully responsible for the equipment upon receipt unless otherwise stated in the contract. The duration of responsibility includes:

- The period of time the equipment is stored locally before installation.
- During the entire installation process.
- While commissioning the equipment.
- The period of time between commissioning and the final acceptance of the equipment by the end user (normally the owner of the vessel which the equipment has been installed).

Unless other arrangements have been made in the contract, the Simrad ES70 guarantee period (as specified in the contract) begins when the acceptance documents have been signed

Receipt, unpacking and storage

Upon accepting shipment of the equipment, the shipyard and/or the dealer should ensure that the delivery is complete and inspect each shipping container for evidence of physical damage. If this inspection reveals any indication of crushing, dropping, immersion in water or any other form of damage, the recipient should request that a representative from the company used to transport the equipment be present during unpacking.

All equipment should be inspected for physical damage, i.e. broken controls and indicators, dents, scratches etc. during unpacking. If any damage to the equipment is discovered, the recipient should notify both the transportation company and Simrad so that Simrad can arrange for replacement or repair of the damaged equipment.

Once unpacked, the equipment must be stored in a controlled environment with an atmosphere free of corrosive agents, excessive humidity or temperature extremes. The equipment must be covered to protect it from dust and other forms of contamination when stored.

General installation requirements

The following installation requirements are applicable to this Simrad delivery.

Approval by classification society

The Simrad ES70 transducer installation must be approved by Det Norske Veritas (DNV) or another classification society. The shipowner and shipyard performing the installation are responsible for obtaining installation approval.

Supply power

The supply voltage to the equipment is to be kept within $\pm 10\%$ of the installation's nominal voltage. Maximum transient voltage variations on the main switchboard's bus-bars are not to exceed -15% to $+20\%$ of the nominal voltage (except under fault conditions).

Simrad recommends that the Simrad ES70 is powered using an Uninterruptable Power Supply (UPS) with sine wave output. The UPS must have the capacity to independently maintain power to the system for a minimum of 10 minutes. This ensures that the system can be switched off in a controlled manner in the event of a power failure.

Compass deviation

Once the installation is complete, the vessel must be swung with the system in both the operative and inoperative modes. The shipowner and captain are responsible for updating the deviation table accordingly with regard to the vessel's national registry and corresponding maritime authority.

Noise sources

The vessel's hull, rudder(s) and propeller(s) should be thoroughly inspected in dry dock prior to installation. Roughness below the water-line deformities in the shell plating and protruding obstacles can create underwater noise. These sources of turbulence must be smoothed or removed as best as possible. It is especially important that the propeller(s) is not pitted or damaged.

Dry docking

Make sure that ample clearance under the sonar trunk and/or protection blister is provided when dry docking the vessel. Avoid locating supporting blocks or structures in the vicinity of this equipment.

Note

The location of the transducer and/or protection blister must be noted on the vessel's docking plan for future reference.

Power down all hydroacoustic systems, and label each system accordingly to prevent accidental power on. Remove circuit breakers if necessary.

Wiring

All cables running between system cabinets located in different rooms and/or on different decks must be supported and protected along their entire lengths using conduits and/or cable trays. Note that the cables must not be installed in the vicinity of high-power supplies and cables, antenna cables or other possible sources of interference.

For more detailed information about cables and wiring, refer to *Basic cable requirements* on page 187.

Installation procedures

This chapter provides the basic information required to install the physical units.

Note

Physical installation of commercial units (computers, printers, displays) is not described in this manual. Refer to the applicable user manual(s) provided with the product.

Topics

- *Basic procedure* on page 17
- *Configuration* on page 18
- *General Purpose Transceiver (GPT) installation* on page 22
- *ES70 Marine Computer installation* on page 24
- *Colour display* on page 24

Related topics

- *General safety rules* on page 176
- *Equipment handling* on page 177
- *Basic cable requirements* on page 187

Basic procedure

This is the basic installation procedure.

- 1 Check that you have received all parts required for the installation; cables, connectors, brackets etc.
- 2 Install the transducer(s) and the transducer cables according to the guidelines in this manual and the drawings provided with the transducer.
- 3 Mount the ES70 Processor Unit (or commercial computer) and the display using the appropriate brackets.
- 4 Connect the computer and display cables:
 - Power cable to display monitor.
 - Power cable to computer.

- Video cable from computer to display monitor.
 - Connect the pointing device (mouse or trackball)
 - Connect the keyboard.
- 5 Mount the General Purpose Transceiver (GPT) using the appropriate brackets.
 - 6 Connect the cables to the transceiver:
 - Transducer cable(s)
 - Power cable(s)
 - If applicable, install a two-wire cable for remote on/off of the General Purpose Transceiver(s).
 - 7 Prepare and install the Ethernet cable(s) between the transceiver(s) and the computer:
 - If only one transceiver is used, you need a twisted pair cable with swapped receive and transmit wires. The cable is connected between the transceiver and the computer.
 - If your system includes more than one transceiver, an Ethernet switch is required.
 - 8 Prepare and install the required sensor interfaces.
 - Connect navigation system (GPS), trawl system and heave sensor. You can connect these using serial lines to the rear side of the ES70 computer, or you can connect the sensors using an Ethernet cable from the ship network.
 - 9 If required, prepare and install the synchronization cable(s).
 - Synchronous transmission is desirable if there are several echo sounders on-board the vessel. For every echo sounder and every transceiver on-board the ship, connect the appropriate pins at the **Auxiliary** connectors together using a two-wire cable.
 - Synchronisation can also be achieved using a serial line on the computer, or by means of the **Auxiliary** connector on each transceiver.

Configuration

The ES70 Fish finding echo sounder system is designed as a modular system. It supports a variety of configurations and frequency options.

- Echo sounder transducer(s)
- Split-beam echo sounder transducer(s)
- General Purpose Transceiver(s) (GPT)
- Processor unit (computer) ^[1]
- Colour display ^[2]

-
1. The ES70 Computer may be provided by Simrad. However, a computer may also be provided locally using a standard commercial type. Note that the chosen computer must provide the capacity and interface facilities required for use with the ES70 Fish finding echo sounder system.
 2. The colour display may be provided locally using a standard commercial type.

- Keyboard ^[3]
- Pointing device (mouse or trackball)
- Ethernet switch (if the system comprises more than one transceiver)
- Software
- Printer (optional)

Echo sounder transducer

A large number of echo sounder transducers are available from Simrad. There are several transducer alternatives for each operating frequency with different beam widths, power rating and mounting arrangements. All transducers are rated 60 or 75 ohms, and each has an efficiency of approximately 50%. Refer to the data sheet and drawings provided with each transducer for technical specifications. Further information about the complete range of transducers are available on <http://www.simrad.com>.

Related topics

- *Transducer Installation* on page 113
- *Simrad transducers* on page 149

Split-beam echo sounder transducers

A large number of echo sounder transducers are available from Simrad. There are several transducer alternatives for each operating frequency with different beam widths, power rating and mounting arrangements. All transducers are rated 60 or 75 ohms, and each has an efficiency of approximately 50%. Refer to the data sheet and drawings provided with each transducer for technical specifications. Further information about the complete range of transducers are available on <http://www.simrad.com>.

A split-beam transducer allows you to enjoy all the functionality provided by the ES70, including biomass calculations, fish position and echo position information panes.

Related topics

- *Transducer Installation* on page 113
- *Simrad transducers* on page 149

General Purpose Transceiver (GPT)

The ES70 Fish finding echo sounder system delivery will include one or more General Purpose Transceivers (GPT) units.

3. The keyboard may be provided locally using a standard commercial type.

Figure 5 General Purpose Transceiver (GPT)



The General Purpose Transceiver (GPT) is a small self-contained unit containing its own power supply. It operates on +12 Vdc or 115-230 Vac. The unit can in principle be mounted anywhere on board the ship, provided that the location is dry and ventilated. Make sure that ample space is provided in front of the unit to allow for maintenance and parts replacements. Power cable and mounting brackets are enclosed. We recommend that the GPT is mounted as close to the transducer(s) as possible.

An Ethernet link connects the General Purpose Transceiver to the Processor Unit (computer). This link may comprise a standard Ethernet cable and - if necessary - an Ethernet switch. The transceiver includes its own Ethernet interface. A network interface board must be fitted to the computer.

A single frequency General Purpose Transceiver accepts one echo sounder transducer, while a dual frequency transceiver accepts two transducers.

The General Purpose Transceiver is available in single beam and split beam configurations. A dual frequency single beam configuration is also provided. The possible operating frequencies are listed in the technical specifications. Typical configurations include:

- GPT-S38(4)-F (single beam 38 kHz, 4 kW)
- GPT-S50(4)-F (single beam 50 kHz, 4 kW)
- GPT-S70(1)-F (single beam 70 kHz, 1 kW)
- GPT-S120(1)-F (single beam 120 kHz, 1 kW)
- GPT-S200(1)-F (single beam 200 kHz, 1 kW)
- GPT-Q38(4)-F (quad (split) beam 38 kHz, 4 kW)
- GPT-Q120(4)-F (quad (split) beam 120 kHz, 4 kW)
- GPT-S38(1)/S50(1)-F (single beam 38 and 50 kHz, 1+1 kW)

Two or more General Purpose Transceivers can exist on the same Ethernet cable. A multi-frequency sounder emerges simply by using several transceivers on the Ethernet cable.

Example: A dual frequency split-beam sounder emerges by connecting two split-beam transceivers to the Ethernet cable.

Example: A triple frequency single-beam sounder emerges by connecting three single-beam transceivers to the Ethernet cable.

Note that for certain operational frequencies, the General Purpose Transceivers is set up using an external power supply.

Related topics

- *General Purpose Transceiver (GPT) specifications* on page 109
- *General Purpose Transceiver (GPT) installation* on page 22

ES70 Marine Computer

The ES70 Marine Computer can be provided for the ES70 Fish finding echo sounder system. We recommend this computer for maritime use, as it contains no moving parts. Microsoft© Windows© XP operating system is used. Power supply, a pointing device (mouse) and the necessary brackets for physical mounting are enclosed. The computer operates from 115 Vac or 230 Vac.

Figure 6 ES70 Marine Computer

**Local purchase**

If you purchase a computer locally, it is important to make sure that the chosen model meets the functional system requirements. It is important that the computer can facilitate the various interface requirements made by the system, and you may need to add extra Ethernet and serial adapters. Also, make sure that the computer design and construction allows for marine use and safe installation. A laptop computer may be used as long as it meets the functional requirements.

Minimum computer requirements

- **Operating system:** Microsoft® Windows® XP® or Microsoft® Windows® 7 [4]
On new installations, we recommend that Microsoft® Windows® 7 is used.
- **Processor speed:** 2 GHz Dual core
- **Memory:** 2.0 Gb
- **Free hard disk space:** 30 Gb
- **Chipset:** Intel
- **Graphic adapter:** DirectX9.0c compatible with Direct3d and OpenGL^[5]

4. The ES70 software does not support Microsoft© Windows© NT or older operating systems.
5. A large number of commercial graphic adapters are available, and Simrad has not tested all of them. Even adapters meeting the minimum specifications may in some cases prove to fail with the ES70 software. We welcome any feedback with comments or experiences with graphic adapters.

- **Interfaces:**
 - One Ethernet interface to communicate with the transceiver
 - One Ethernet interface to communicate with ship's local area network (if required)
 - One or more serial line interfaces (depends on how many interfaces that are required for the specific integration)
- **Display resolution:** 1280 x 1024^[6]

Colour display

A colour display monitor can be provided with the echo sounder system. Any commercial display can also be used.

Software

All echo sounder configurations run identical software. The software automatically adapts to the number and type of installed transceivers during power-on. Upon delivery, the software is installed on the computer, as well as supplied on a CD-ROM. Software updates are distributed on a CD-ROM.

Printer

A printer can be supplied, or purchased locally. Most standard off-the-shelf colour printers can be used. A standard Windows driver is required, this is normally supplied with the printer.

General Purpose Transceiver (GPT) installation

The General Purpose Transceiver (GPT) is a small self-contained unit containing its own power supply. It operates on +12 Vdc or 115-230 Vac. The unit can in principle be mounted anywhere on board the ship, provided that the location is dry and ventilated. Make sure that ample space is provided in front of the unit to allow for maintenance and parts replacements. Power cable and mounting brackets are enclosed. We recommend that the GPT is mounted as close to the transducer(s) as possible.

6. This is the minimum resolution. As with all other Windows applications, the ES70 software will work with higher resolutions, provided that it is supported by the graphic adapter in the computer and the display connected.

Figure 7 General Purpose Transceiver (GPT)



Preparations

- Two brackets and four pan head screws are enclosed. The side walls of the unit each hold six screws; three screws along the bottom edge and three screws along the top edge. The brackets can be vertically mounted in three different positions;
 - Use the two rear holes, or
 - Use the two centre holes, or
 - Use the two front holes.
- The brackets can be horizontally mounted in four different ways using either the bottom edge holes or the top edge holes. The brackets can be horizontally mounted in four different ways using either the bottom edge holes or the top edge holes.

Procedure

To make sure that the procedure is followed correctly, and in the right order, tick off each task after it has been done.

- 1 Unscrew two screws from each side wall.
- 2 Mount the brackets using the pan head screws.
- 3 Position the unit on the surface and mark the four mounting holes.
- 4 Remove the unit, and drill mounting holes.
- 5 Mount the General Purpose Transceiver (GPT) using the appropriate brackets.
- 6 Mount the unit to the surface using 5 mm bolts.
- 7 Connect the grounding cable.

External power supply

In order to avoid electrical noise, certain GPT configurations are supplied with an external power supply. This supply is mounted by means of two brackets. Observe the outline dimension drawing.

Related topics

- *GPT Outline dimensions* on page 102
- *GPT Power supply outline dimensions* on page 104
- *General Purpose Transceiver (GPT) specifications* on page 109

ES70 Marine Computer installation

The ES70 Marine Computer is an industrial computer. It is small, rugged, and contains no moving parts. This means that fans, hard disks and CD drives are omitted. The computer provides two Ethernet sockets, four RS-232 serial lines and several USB connectors. The hard disk is replaced with a commercial 4 Gb flash disk.

The ES70 Marine Computer is easily mounted with the brackets supplied with the unit. A small external power supply is provided, and must be placed near the computer.

Figure 8 ES70 Marine Computer



Preparations

Two brackets and eight bolts enclosed. Mount the two brackets at the bottom of the computer.

Installation procedure

To make sure that the procedure is followed correctly, and in the right order, tick off each task after it has been done.

- 1 Locate the most convenient location for the computer. Make sure that you can access both the rear and front side of the computer after it has been installed. In order to allow for future maintenance, mount the computer with its rear panel available for immediate access.
- 2 Observe the outline dimension drawing. Mark the location of the six holes provided on the two brackets.
- 3 Mount the unit using six bolts or screws.
- 4 When you install the cabling, make sure that the various adapter and cables are secured, and able to withstand vibration and the movements of the vessel.

Related topics

- *ES70 Marine Computer specifications* on page 111

Colour display

Different commercial colour displays are available. For installation and operation of the chosen display unit, refer to the manual supplied with the unit.

Installation procedure

To ensure correct operation, tick off every item when the action has been carried out.

- 1 Install the colour display as described the applicable documentation provided with the unit.
 - The display unit must be located so that it is best protected from glare which reduces readability.
 - The display may be mounted in a panel, on the desktop or bulkhead, or overhead.
 - Make sure that adequate ventilation is available to avoid overheating.
 - The compass safe distance must be allowed for when planning the unit's location.
 - Ensure that the installation allows for the physical movements and forces normally experienced on a vessel.
 - Ensure that enough space is provided for maintenance work.

ES70 Cable layout

This chapter describes the installation requirements for the ES70 Fish finding echo sounder system cables.

Note

All electronic installations and corresponding wiring must be in accordance with the vessel's national registry and corresponding maritime authority and/or classification society. Observe Basic cable requirements on page 187.

If no such guidelines exist, we recommend that Det Norske Veritas (DNV) Report No. 80-P008 «Guidelines for Installation and Proposal for Test of Equipment» is used as a guide.

Topics

- *Cable plan on page 27*
- *List of cables on page 31*
- *Connector identifications on page 35*
- *Cable drawings on page 40*

Cable plan

Due to its modular design, the Simrad ES70 Fish finding echo sounder system can be set up in a variety of configurations to suit individual needs for operational frequencies, transducers and operational facilities. It is not practical to define specific cable plans for all these configurations.

Basic cable plans provided

To illustrate the variety of configurations, the following basic cable plans are provided:

- Standard setup with one computer and one General Purpose Transceiver.
- Standard setup with one computer and more than one General Purpose Transceiver.

Note

The General Purpose Transceiver (GPT) used by the Simrad ES70 Fish finding echo sounder can be set up to work with maximum four -4- operational frequencies. This means that you can use four single frequency transceivers (single or split beam), two dual frequency transceivers, or any combinations of these.

ES70 Cable plan

Figure 9 Cable plan, topside

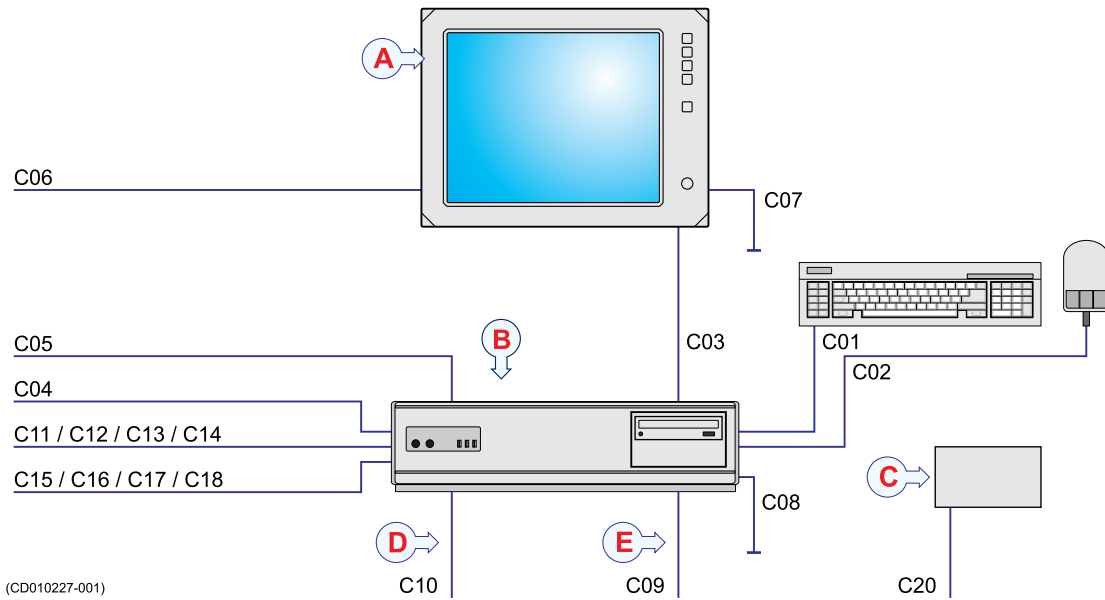

- A** *Display*
- B** *Computer*
- C** *Junction box for transducer cable (optional)*
- D** *Ethernet cable to vessel LAN (optional)*
- E** *Ethernet cable to transceiver*

Figure 10 Cable plan, single General Purpose Transceiver (GPT)

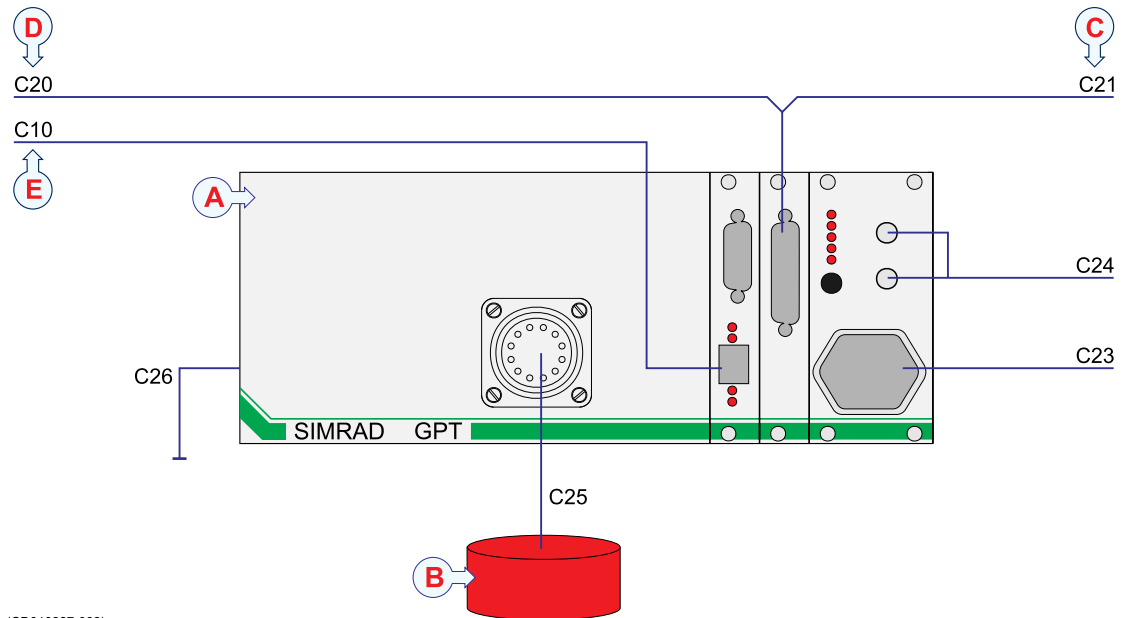

- A *General Purpose Transceiver (GPT)*
- B *Transducer(s)*
- C *Interfaces to peripheral devices*
- D *Cable to on/off switch*
- E *Ethernet cable to topside computer*

Figure 11 Cable plan, dual General Purpose Transceiver (GPT)

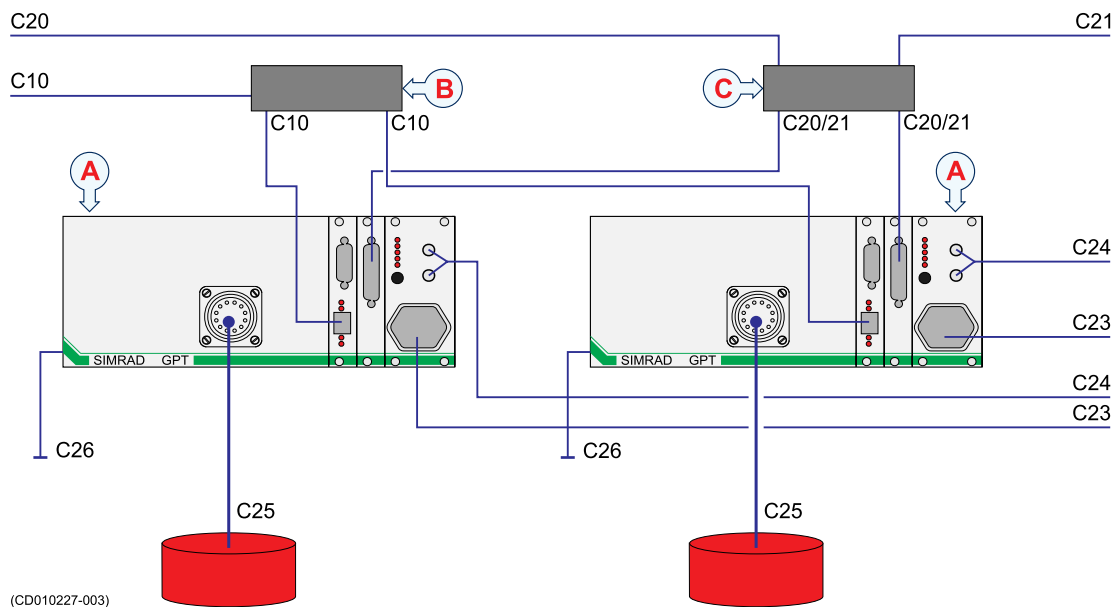

(CD010227-003)

Echo sounder items

- A General Purpose Transceiver (GPT)
- B Ethernet switch
- C Wiring block

Note that the following cable are not shown on the illustration:

- C27: Power cable to Ethernet switch
- C28: Power cable to external power supply (only for certain GPT frequencies)

List of cables

The list below specifies each cable used on the echo sounder system. References are made to the location of connector(s), detailed cable drawings and specifications. The cables are listed in numerical order.

ES70 Cable list

C1 EK60/C01 Keyboard

This is a standard keyboard cable, and it is usually fixed to the keyboard. The connection normally depends on the make and model of the computer. Most recent computers use a USB plug, older types use PS/2.

Note that the keyboard is an optional item. It is not a part of the ES70 delivery.

C2 EK60/C02 Mouse, trackball or other pointing device

This is a standard computer mouse or other pointing device cable. It is physically attached to the mouse.

C3 EK60/C03 Display cable

This cable is normally provided with the display. It is a standard commercial cable. Two types may be used, depending on the video output on the computer.

- *VGA/SVGA Display* on page 51
- *DVI-I Display* on page 54

C4 EK60/C04 Printer

A printer can be connected to the computer. A cable for this is normally provided with the printer. The most common interface formats are parallel and USB.

- *USB* on page 52
- *Parallel printer* on page 53

C5 EK60/C05 Computer to AC mains

This cable is provided with the computer. It is normally a standard mains supply cable.

- *AC mains (IEC 60320)* on page 48

C6 EK60/C06 Colour display to AC mains

This cable is provided with the colour display. It is normally a standard commercial mains cable.

- *AC mains (IEC 60320)* on page 48

C7 EK60/C07 Colour display to ground

When applicable, this cable must be provided by the installation shipyard. It is a standard commercial ground cable.

- *Vessel ground* on page 46

C8 EK60/C08 Computer to ground

When applicable, this cable must be provided by the installation shipyard. It is a standard commercial ground cable.

- *Vessel ground* on page 46

C9 EK60/C09 Ethernet to ship local area network (LAN)

If the computer is equipped with two Ethernet connectors, it may also be connected to the local area network (LAN). A standard “straight” Ethernet cable is required, and the cable must be provided by the installation shipyard.

Note that screened Ethernet (CAT5 or better) cables must be used.

- *RJ45 Ethernet, straight* on page 49

C10 EK60/C10 Ethernet to General Purpose Transceiver (GPT)

It is strongly recommended to equip the computer with two network adapters. One will be used to communicate with the General Purpose Transceiver(s), while the other is used to connect the ES70 system to the local area network. Failure to use separate network adapters will cause a heavy traffic load on the common network. This will inhibit normal traffic on this network, and degrade the operational capabilities of the echo sounder system.

With one transceiver, use a “crossover” Ethernet cable between the computer and the transceiver.

With more than one transceivers, add an Ethernet switch to the system, and use “straight” Ethernet cables.

It is very important that high quality (CAT5 or better) Ethernet cables are used. Cables with lower bandwidth capacity will reduce the system performance.

- *RJ45 Ethernet, straight* on page 49
- *RJ45 Ethernet, crossover* on page 50

C11 EK60/C11 Serial interface line

The number of serial lines available depends on the chosen computer make and model. The Simrad MC71 computer provided with the EK60 provides five serial lines, four of these are optically isolated. Additional serial lines may be added if required. A multiple interface circuit board is used, and the connector requires a special adapter.

One serial line can be used to provide external synchronisation with other hydroacoustic systems (sonars, echo sounders). If this option is used, the synchronisation cable to the General Purpose Transceiver (GPT) is not used.

- *Generic RS-232 Serial line* on page 41
- *Generic RS-232 Serial line* on page 42
- *RS-232 as external trigger* on page 43
- *ITI serial line* on page 60
- *PI44/54 serial line* on page 61
- *PI30/32 serial line* on page 62

- *Sonar serial line* on page 63
- *Serial line adapter* on page 55

C12 EK60/C12 Serial interface line (same as C11)

C13 EK60/C13 Serial interface line (same as C11)

C14 EK60/C14 Serial interface line (same as C11)

C15 EK60/C15 Universal Serial Bus (USB) interface

Most computers support one or more USB connectors for peripheral devices. In a typical echo sounder configuration, the USB connectors are not used. However, a USB interface may be used to accept serial line information (providing a converter is used). You can also use the USB interfaces to connect a mouse, keyboard, printer or memory devices. The number of USB sockets available depends on your computer make and model.

- *USB* on page 52

C16 EK60/C16 Universal Serial Bus (USB) interface (same as C15)

C17 EK60/C17 Universal Serial Bus (USB) interface (same as C15)

C18 EK60/C18 FireWire interface

Most current computers have a FireWire interface. This interface is however not required by the echo sounder system.

C19 Not used

C20 EK60/C20 Remote control of GPT power

The General Purpose Transceiver (GPT) allows you to design a simple box with a separate on/off switch for the transceiver. An on/off switch will prevent the transceiver from being powered up constantly. Some commercial displays provide this functionality by means of a “Remote” connector on the rear side. The GPT unit is switched off when pin 23 on the “Auxiliary” connector is grounded to pin 22. If more than one GPT is used in a system, a single switch can be used to switch all the transceivers on and off simultaneously. To achieve this, pin 23 on all the “Auxiliary” connectors are connected to one of the switch terminals, while pin 22 on all the connectors are connected to the other terminal. This method will however not allow you to reset a single transceiver. You must also ensure that this wiring does not create a ground loop.

Both this cable and the box must be supplied by the installation shipyard.

Do not use the spare wires in the Ethernet cable to provide the remote control facility!

- *GPT connections* on page 35
- *GPT remote on/off* on page 56

C21 EK60/C21 GPT interface to external synchronisation

This cable is used to connect the General Purpose Transceiver (GPT) to an external system in order to provide transmission control (synchronisation). This is a very useful feature if you have other hydroacoustic systems on board. If more than one General Purpose Transceiver (GPT) is used by the ES70, the

synchronization signal **TrigIn** must be connected to all of them. The cable(s) must be supplied by the installation shipyard. If the ES70 system is synchronised using an RS-232 serial line connected to the computer, this cable is not installed.

- *GPT connections* on page 35
- *GPT trigger / synchronisation* on page 58

C22 EK60/C22 Not used

C23 EK60/C23 GPT to AC mains

This cable is provided with the ES70. It is a standard mains supply cable. Due to certain properties of the commercial built-in power supply, a number of transceiver configurations operating on 230 Vac will be supplied with a separate power supply. When this supply is used, this 230 Vac power cable is not used. The external power supply is connected to the battery inputs using the DC cable.

- *AC mains (IEC 60320)* on page 48

C24 EK60/C24 GPT to DC power supply

The General Purpose Transceiver Unit (GPT) can be powered from a DC supply or from a standard car battery. The power cable must be provided by the installation shipyard.

- *GPT connections* on page 35
- *GPT external power* on page 47
- *GPT battery* on page 59

C25 EK60/C25 Transducer cable(s)

The ES70 can be used with a large variety of transducers. The large transducer connector on the General Purpose Transceiver Unit (GPT) has been prepared to accept all of them, provided that the necessary circuit boards are fitted to the unit.

- *Transducer connections* on page 37

C26 EK60/C26 GPT to ground

When applicable, this cable must be provided by the installation shipyard. It is a standard commercial ground cable.

- *Vessel ground* on page 46

C27 EK60/C26 Ethernet switch to AC mains

Most Ethernet switches are supplied with a separate power supply.

- *Commercial power supply* on page 45

C28 EK60/C31 GPT DC power supply to AC mains

This cable is provided with the power supply. It may be a standard mains supply cable, or it may be integrated with the power supply.

- *AC mains (IEC 60320)* on page 48

Connector identifications

This section provides the necessary illustrations to identify the various connectors and terminal boards on the echo sounder units.

GPT connections

The illustration below shows the cable sockets used on the General Purpose Transceiver (GPT).

Figure 12 GPT connections

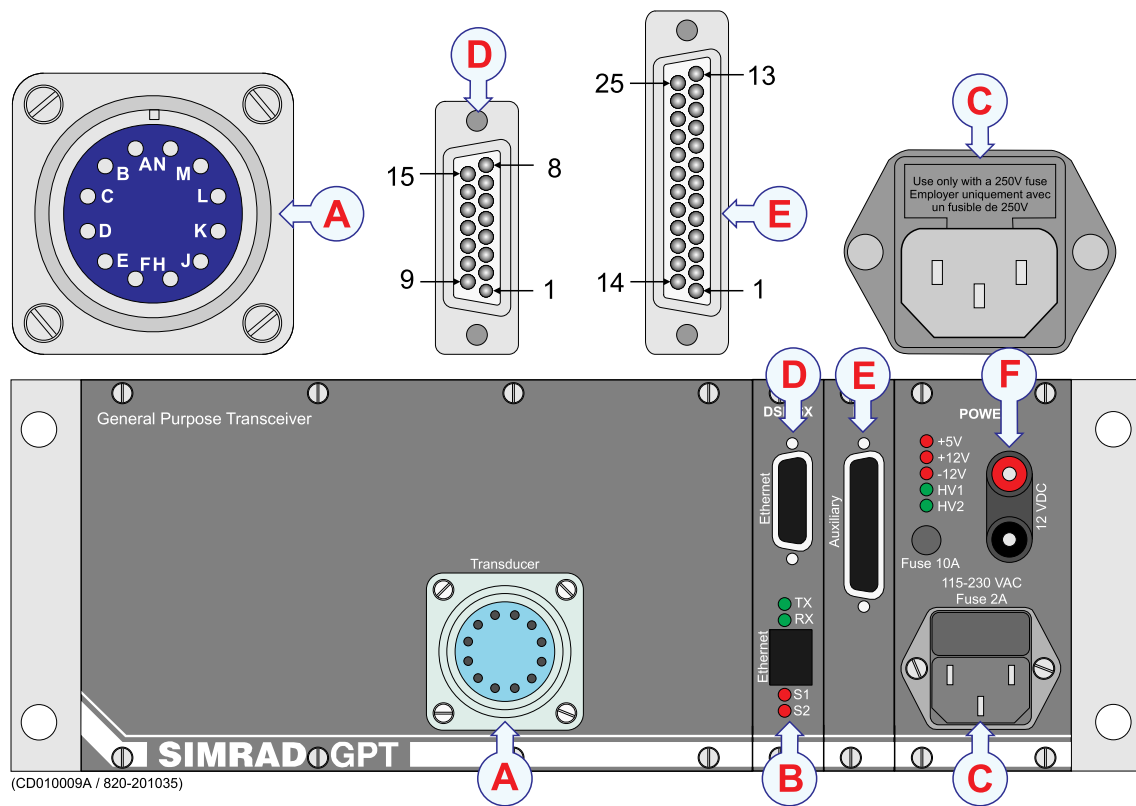

- A** *Transducer connector*
- B** *Ethernet (RJ45)*
- C** *AC mains connector with fuse*
- D** *Ethernet connector (normally not used)*
- E** *Auxiliary connector*
- F** *+12 Vdc input*

Figure 13 GPT Auxiliary connector

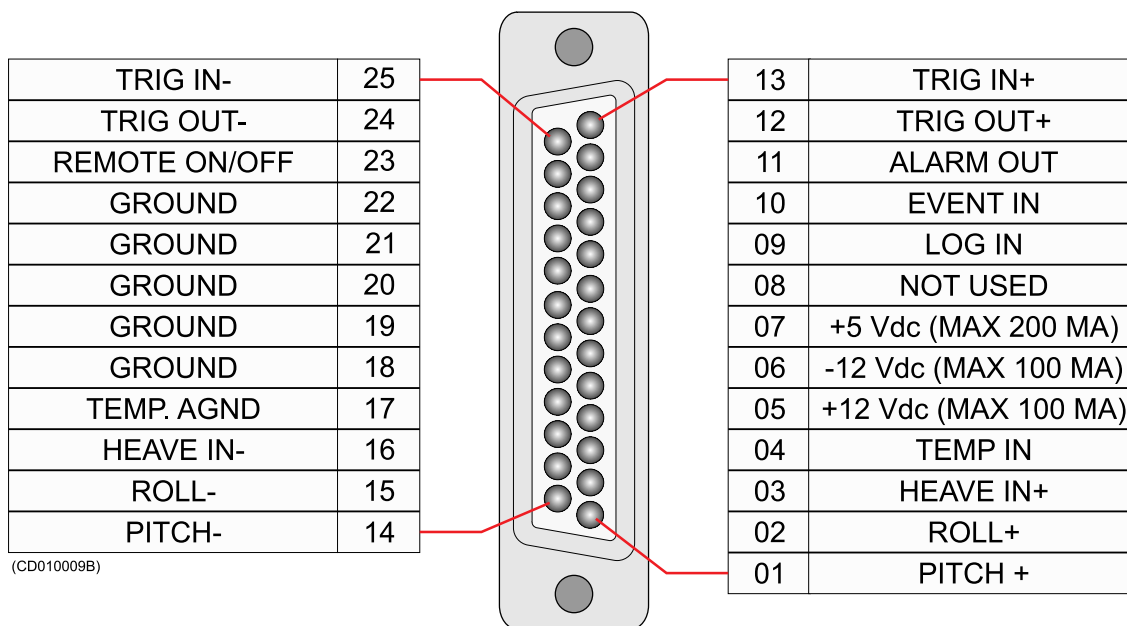

Note

The following inputs and outputs are not supported on the ES70 Fish finding echo sounder:

- Temperature input
 - Heave, roll and pitch inputs
 - Event input
 - Log input
 - Alarm output
-

Transducer connections

Transducer types

The echo sounder can be used with a large variety of transducers. The large transducer connector on the General Purpose Transceiver Unit (GPT) has been prepared to accept all of them, provided that the appurtenant circuit boards are fitted to the unit. The following transducer types may be used:

- Single frequency, single beam (high or low power)
- Single frequency, dual beam (wide or narrow)
- Single frequency, split beam

Transducer cables

For the majority of the transducers, the cables are supplied by Simrad. These are normally physically fastened to the transducer.

Note

The distance between the General Purpose Transceiver and the transducer(s) must be as short as possible to avoid interference and noise.

All transducer cables must be run in steel conduits. Cable shields must be connected to the plug housing.

If the distance between the transducer and the transceiver exceeds the length of the cable, a junction box must be used. The cable between the junction box and the transceiver must then be supplied by Simrad, and this must be the same type as used on the transducer(s).

Transducer cable splicing

If you need to cut or lengthen the transducer cable, you must splice it correctly. The cable between the junction box and the transceiver must then be supplied by Simrad, and this must be the same type as used on the transducer(s). To splice the cable, use a metal junction box with EMC cable glands and a terminal block. The terminal block must provide solid fastening of the cable ends as well as sufficient insulation between the wires. We recommend that the cable screen is connected to the junction box chassis using the EMC cable glands, but if you do this, the junction box chassis must not be connected to vessel's ground.

Note

Do not solder the wires together with only electrical tape for insulation. This will result in electrical noise and reduced operational performance.

Do not connect the cable screen to the vessel's ground.

Transducer connection drawings

- *Single beam/normal power transducer* on page 64

- *Single beam/high power transducer* on page 65
- *Dual beam (wide or narrow) transducer* on page 66
- *Split beam transducer* on page 67
- *Split beam transducer to single beam transceiver* on page 68
- *Dual frequency, single beam transducer* on page 69
- *ES38–10 transducer* on page 70
- *Single beam transducer to split beam transceiver* on page 71
- *12-16/60 transducer* on page 72
- *Deep water, split beam transducer* on page 73
- *50/200 Combi C transducer* on page 74
- *38/200 Combi C transducer* on page 75

GPT connector

Ensure that the transducer connector is wired correctly regarding inner and outer screen.

Figure 14 Transducer connector

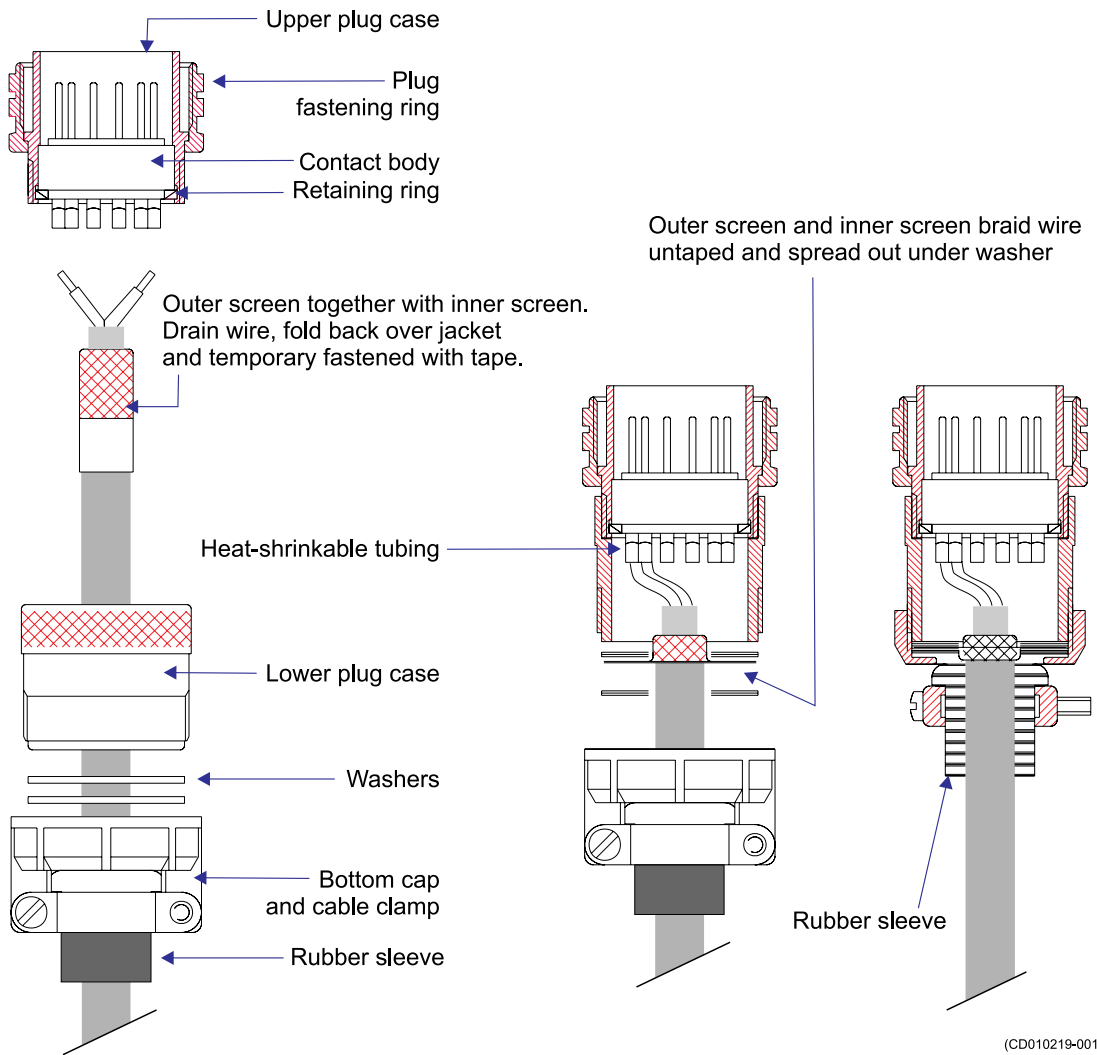

Cable drawings

This chapter provides details cable drawings offering cable specifications and termination information.

Cable specification drawings

- *Generic RS-232 Serial line* on page 41
- *Generic RS-232 Serial line* on page 42
- *RS-232 as external trigger* on page 43
- *Sonar synchronisation* on page 44
- *Commercial power supply* on page 45
- *Vessel ground* on page 46
- *GPT external power* on page 47
- *AC mains (IEC 60320)* on page 48
- *RJ45 Ethernet, straight* on page 49
- *RJ45 Ethernet, crossover* on page 50
- *VGA/SVGA Display* on page 51
- *USB* on page 52
- *Parallel printer* on page 53
- *DVI-I Display* on page 54
- *Serial line adapter* on page 55
- *GPT remote on/off* on page 56
- *GPT trigger / synchronisation* on page 58
- *GPT battery* on page 59
- *ITI serial line* on page 60
- *PI44/54 serial line* on page 61
- *PI30/32 serial line* on page 62
- *Sonar serial line* on page 63
- *Single beam/normal power transducer* on page 64
- *Single beam/high power transducer* on page 65
- *Dual beam (wide or narrow) transducer* on page 66
- *Split beam transducer* on page 67
- *Split beam transducer to single beam transceiver* on page 68
- *Dual frequency, single beam transducer* on page 69
- *ES38-10 transducer* on page 70
- *Single beam transducer to split beam transceiver* on page 71
- *12-16/60 transducer* on page 72
- *Deep water, split beam transducer* on page 73
- *50/200 Combi C transducer* on page 74
- *38/200 Combi C transducer* on page 75

Generic RS-232 Serial line

This cable holds a multi purpose serial line. It provides interface with any peripheral unit. One end of the cable connects to the local unit (DTE) with a 9-pin D-connector, while the other connects to the peripheral (DCE) as described in the peripheral unit's documentation. Note that this cable does not support all the signals in the standard RS-232 specification.

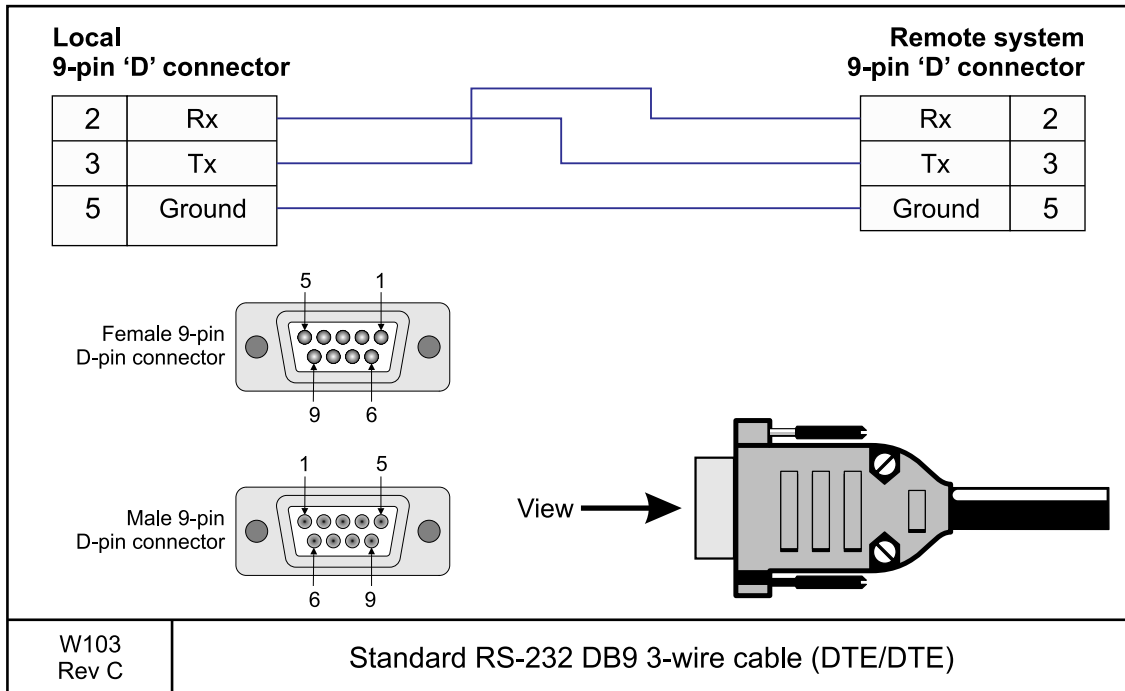

Cable specifications

- Conductors: 2 x 2 x 0.5 mm²
- Screen: Screened twisted pairs and overall braided
- Voltage: 60 V
- Maximum diameter: Limited by the plugs

Generic RS-232 Serial line

This cable comprises a multi purpose serial line. It provides interface with any peripheral unit. One end of the cable connects to the local unit (**DTE**) with a 9-pin D-connector, while the other connects to the peripheral (**DCE**) as described in the peripheral unit's documentation.

In many cases, only the **RxD**, **TxD** and **GND** pins are used. Twisted pairs are sufficient in the cable.

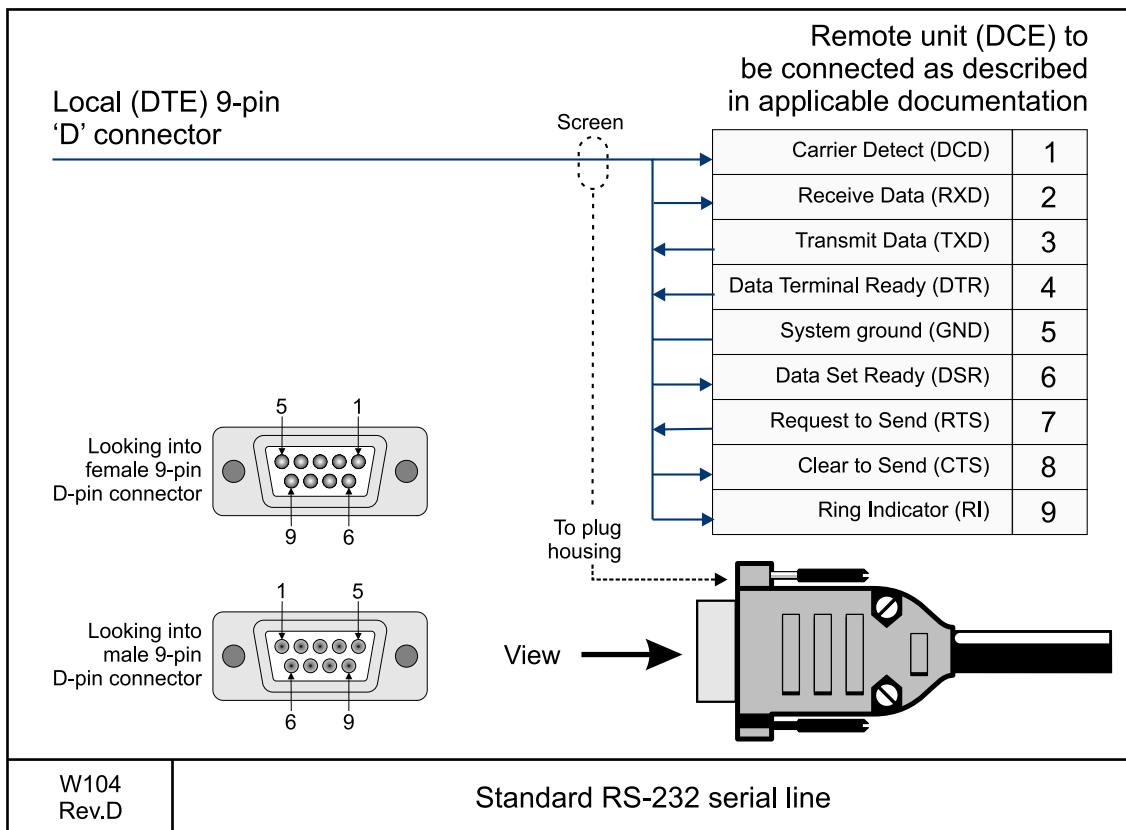

Cable specifications

- Conductors: 5 x 2 x 0.5 mm²
- Screen: Screened twisted pairs and overall braided
- Voltage: 60 V
- Maximum diameter: Limited by the plugs

RS-232 as external trigger

This cable comprises an RS-232 serial line applied as an external trigger. It provides interface with any peripheral unit that requires transmit/receive synchronization. One end of the cable connects to the local unit with a 9-pin D-connector, while the other connects to the peripheral system as described in the peripheral unit documentation.

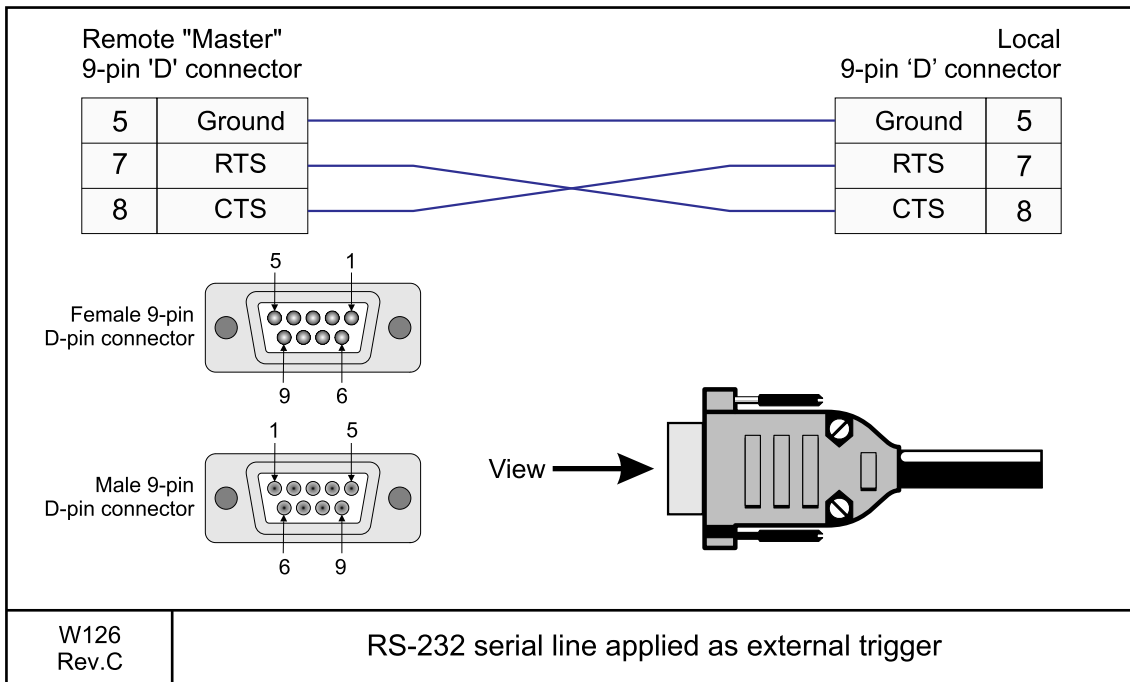

Cable specifications

- Conductors: 9 x 2 x 0.5 mm²
- Screen: Screened twisted pairs and overall braided
- Voltage: 60 V
- Maximum diameter: Limited by the plugs

Sonar synchronisation

This cable connects the echo sounder to the Interface Unit on a Simrad sonar. The cable allows for external synchronisation of the sonar transmission.

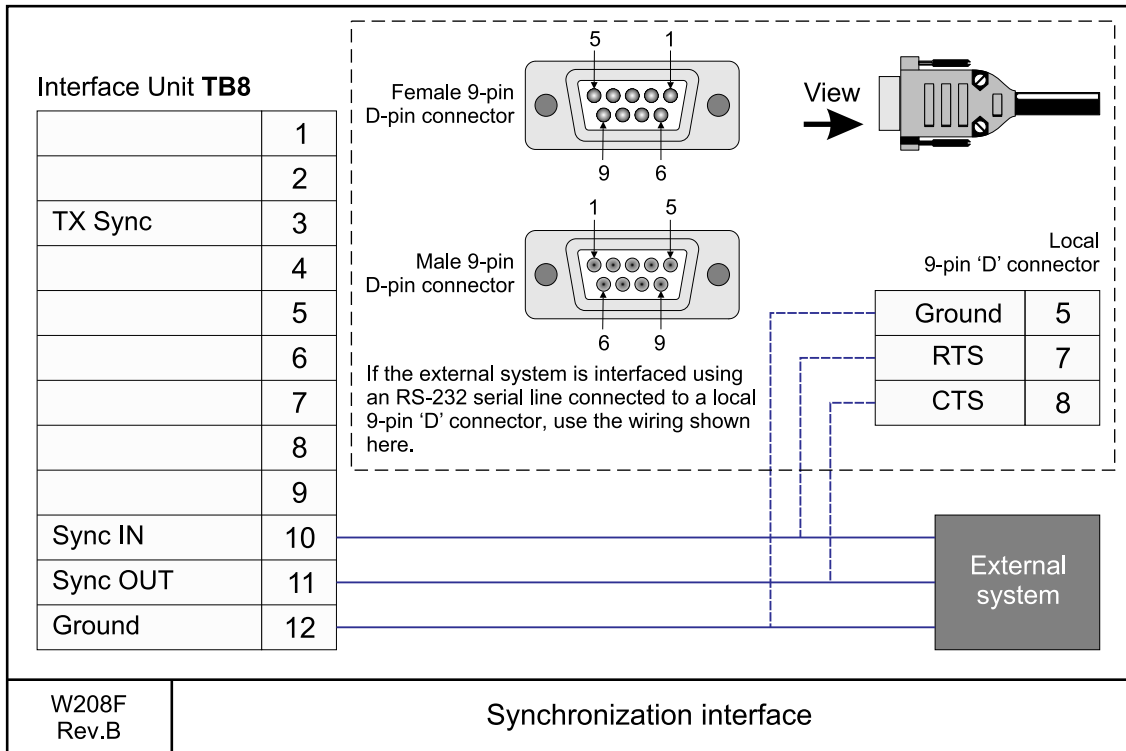

Cable specifications

- **Conductors:** 4 x 0.5 mm²
- **Screen:** Overall braided
- **Voltage:** 60 V
- **Maximum diameter:** Defined by the plugs

Commercial power supply

This is a standard commercial power supply. The input is normally 115 and/or 230 Vac, while the output voltage and power capacity is set up to match the device it shall be used with. A large variety of these power supplies exist. Some will also have an in-line power “box”. These types will have an AC power cable on one side, and the DC output supply cable on the other.

	<p>The power supply is fitted with plug to suit the national standard. (British standard shown as example only.)</p> <p>Plug type and electrical properties on DC output are set to fit the device to be powered.</p>
<p>W300 Rev.B</p>	<p>Commercial power supply</p>

Cable specifications

- Not applicable

Vessel ground

This cable is used to connect a system unit to the ship's ground. Note that this cable must be as short as possible.

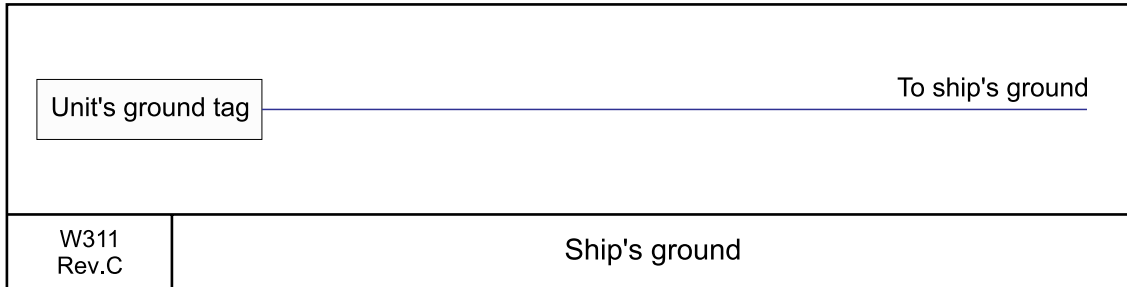

Cable specifications

- **Conductors:** 1 x 6 mm²
- **Screen:** None
- **Voltage:** 60 V
- **Maximum diameter:** N/A

GPT external power

In order to suppress electric noise, certain echo sounder configurations require an external power supply. This power supply is then used instead of the 230 Vac power cable.

Note

The external power supply is not required for transceivers operating on 115 Vac.

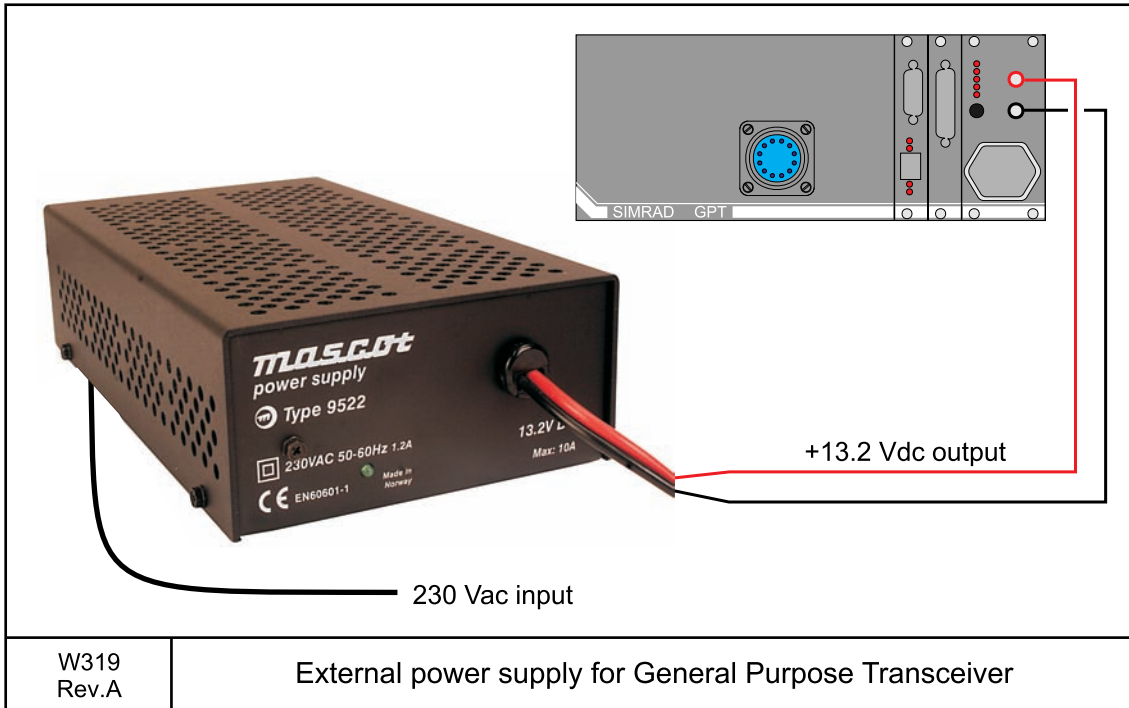

AC mains (IEC 60320)

This is a commercial 230 Vac power cable for mains power. One end is fitted with an IEC plug, the other with a standard European mains plug. This is a standard cable type supplied in different lengths. For additional details, see http://en.wikipedia.org/wiki/IEC_320.

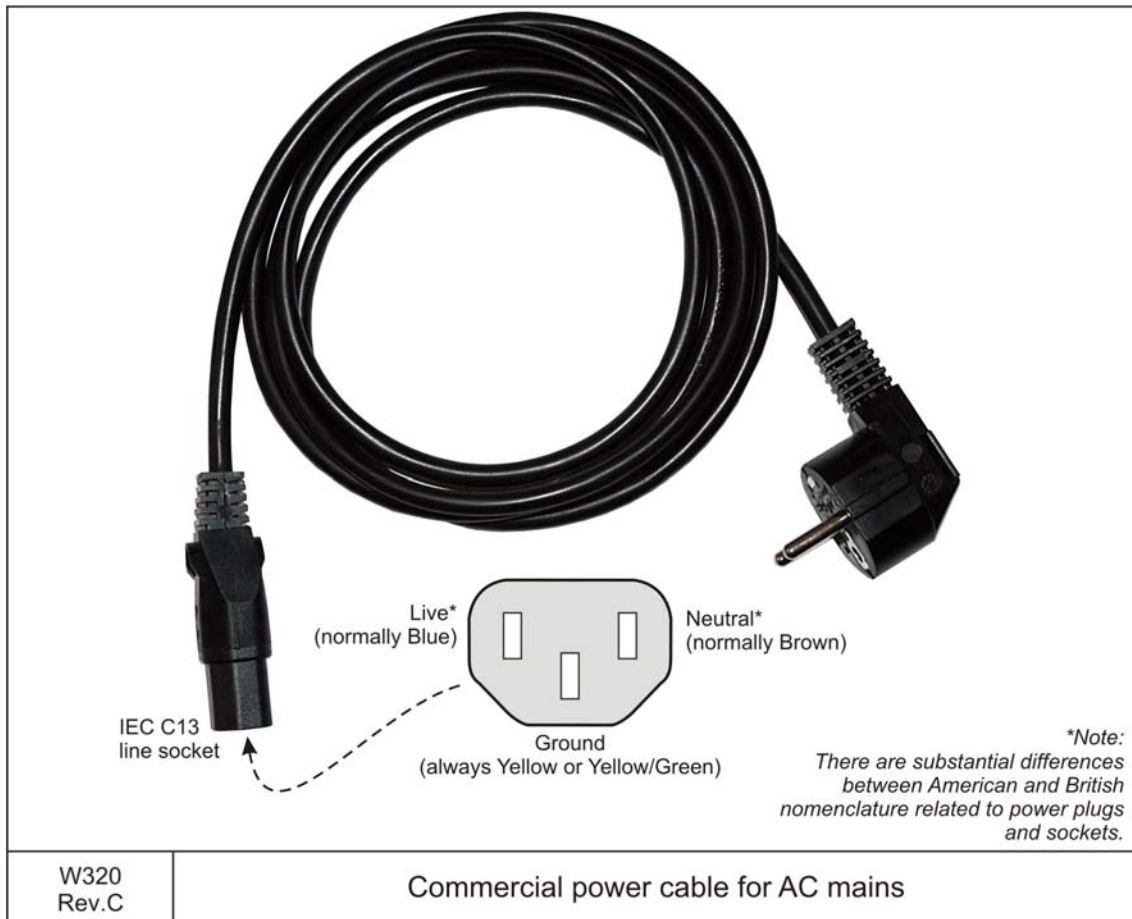

Cable specifications

- **Conductors:** 2 x 1.5 mm² + GND
- **Screen:** None
- **Voltage:** 750 V
- **Maximum diameter:** Set by the plugs

RJ45 Ethernet, straight

This cable is used to provide standard Ethernet connections. Note that various categories exists. Normally, **CAT-5E** and **CAT-6** cables are used in local area networks with bandwidth exceeding 100 Mbit. Ethernet cables are available commercially in different lengths, colours and categories.

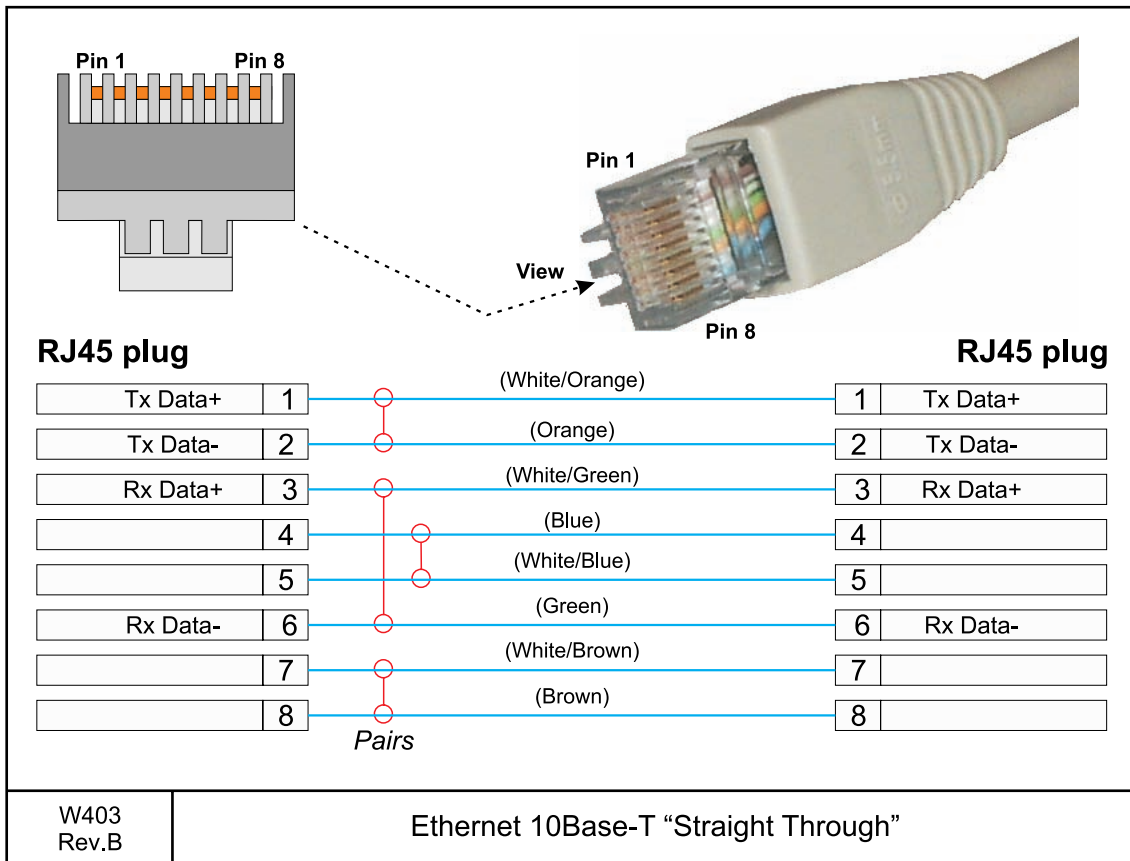

In order to prevent noise and crosstalk, you are strongly advised to use the cable pairs indicated in the drawing.

Cable specifications

- Not applicable. This is a commercial cable.

More information

- <http://en.wikipedia.org>

RJ45 Ethernet, crossover

This cable is used to provide standard ethernet connections. Note that various categories exists. Normally, **Cat.5** and **Cat.6** cables are used in local area networks with bandwidth exceeding 100 Mbit

Ethernet cables are available commercially in different lengths, colours and categories.

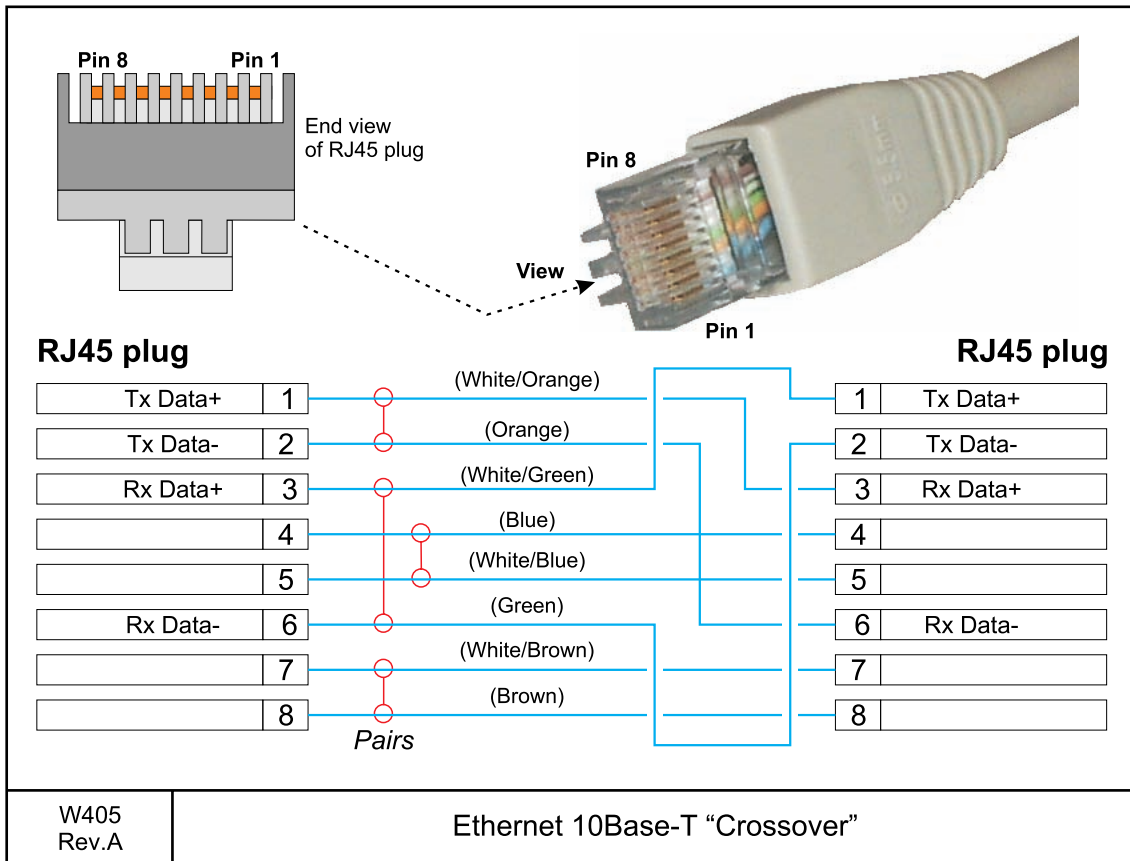

In order to prevent noise and crosstalk, you are strongly advised to use the cable pairs indicated in the drawing.

Cable specifications

- Not applicable. This is a commercial cable.

More information

- <http://en.wikipedia.org>

VGA/SVGA Display

This is a standard VGA and SVGA video cable. One end is normally connected to the display, while the other end is terminated in a standard D-connector.

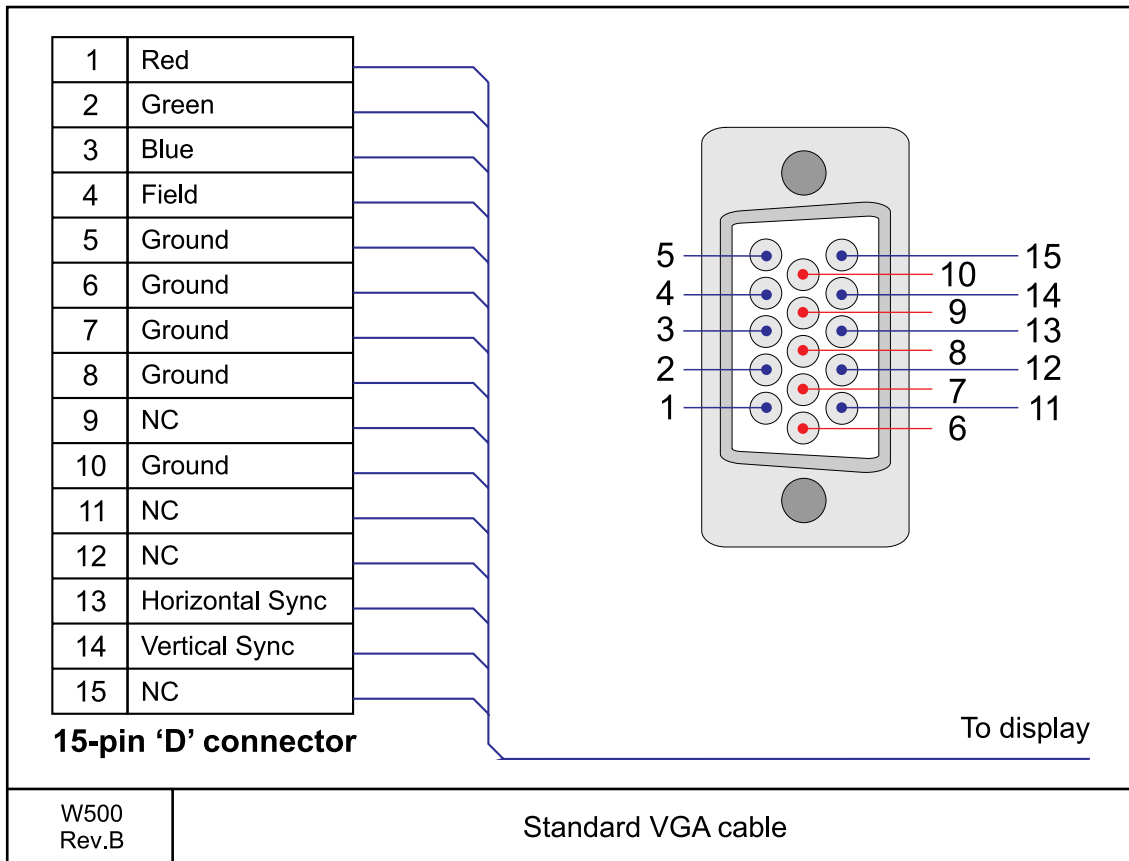

Cable specifications

- Not applicable. This is a commercial cable.

USB

Just about any computer that you buy today comes with one or more Universal Serial Bus (USB) connectors on the back. These connectors let you attach everything from mouse to printers to your computer quickly and easily. Since the operating system supports USB, installation of device drivers is also easy. In most cases, the USB cable is commercial, and they are normally supplied with the external devices, However, USB cables are also available commercially in different fixed lengths. For more information, see also <http://en.wikipedia.org>.

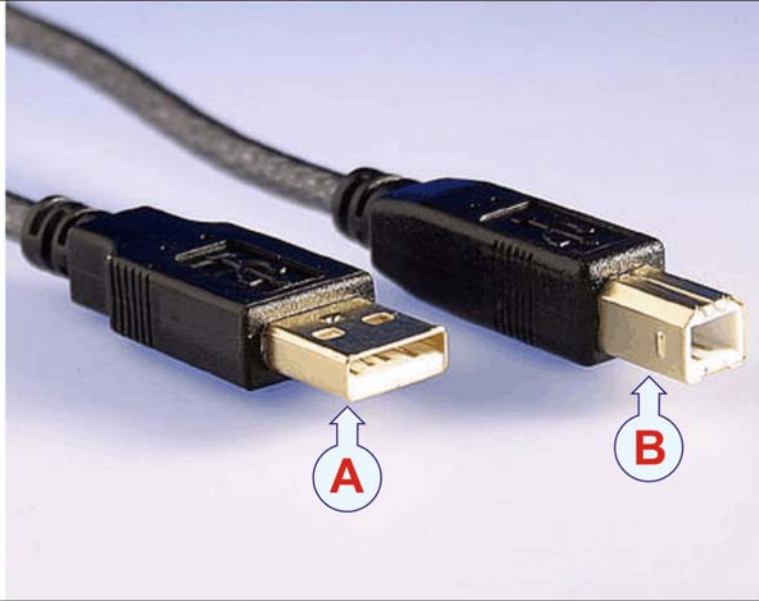
<p>Universal Serial Bus (USB) cable terminated with an A-plug in one end and a B-plug in the other.</p> <p>Internal cables:</p> <p>Pair 1: 28 AWG twisted pair (data, green, white)</p> <p>Pair 2: 20 AWG twisted pair (Power, red, black)</p> <p>Shield: Foil and braid</p>	
<p>W501 Rev.B</p>	<p>Commercial USB cable</p>

Cable specifications

- Not applicable. This is a commercial cable.

Parallel printer

This is a standard “Centronics” parallel printer cable. It is provided ready-made with printers, and also obtainable from commercial retailers.

Termination is made with 25-pin “D-sub” connector in one end, parallel port connector in the other end (IEEE 1284-A)

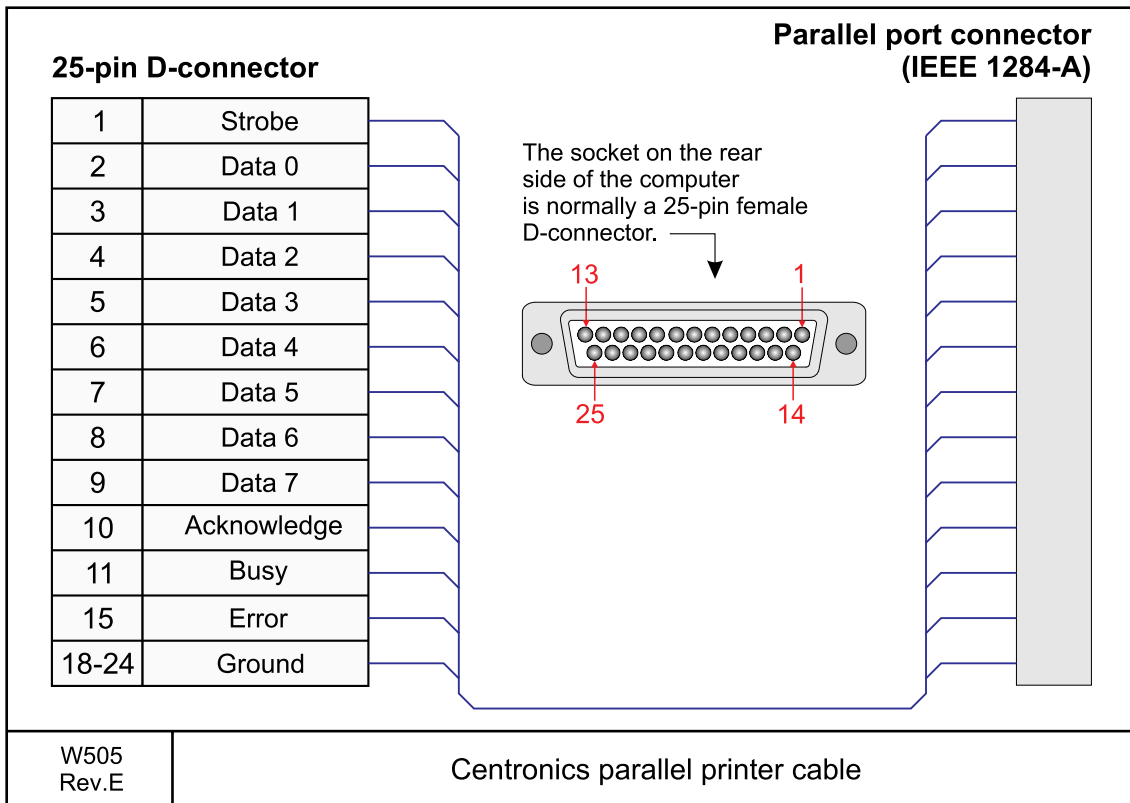

Cable specifications

- Not applicable. This is a commercial cable.

DVI-I Display

This cable is a standard DVI-I cable. It is normally provided with the colour display.

For more information about the DVI signals, see <http://en.wikipedia.org>.

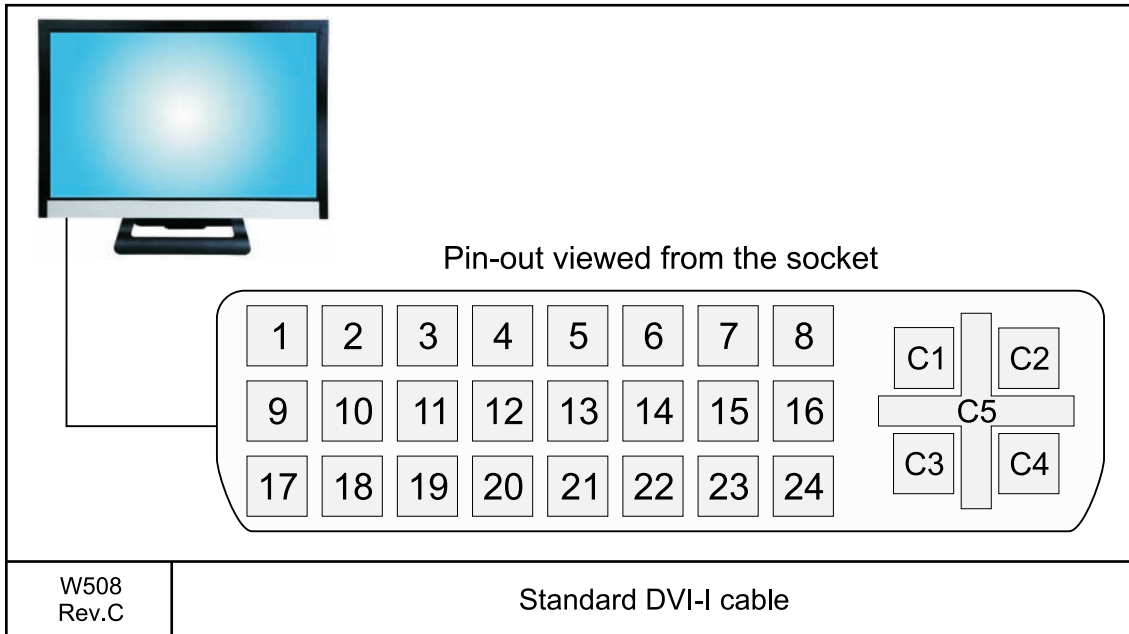

Pin	Signal	Pin	Signal
1	TMDS Data 2- (Digital red - (Link 1))	15	Ground (Return for pin 14 and analog sync)
2	TMDS Data 2+ (Digital red + (Link 1))	16	Hot plug detect
3	TMDS Data 2/4 shield	17	TMDS data 0- (Digital blue - (Link 1) and digital sync)
4	TMDS Data 4- (Digital green - (Link 2))	18	TMDS data 0+ (Digital blue + (Link 1) and digital sync)
5	TMDS Data 4+ (Digital green + (Link 2))	19	TMDS data 0/5 shield
6	DDC clock	20	TMDS data 5- (Digital red - (Link 2))
7	DDC data	21	TMDS data 5+ (Digital red + (Link 2))
8	Analog vertical sync	22	TMDS clock shield
9	TMDS Data 1- (Digital green - (Link 1))	23	TMDS clock+ (Digital clock + (Links 1 and 2))
10	TMDS Data 1+ (Digital green + (Link 1))	24	TMDS clock- (Digital clock - (Links 1 and 2))
11	TMDS Data 1/3 shield	C1	Analog red
12	TMDS Data 3- (Digital blue - (Link 2))	C2	Analog green
13	TMDS Data 3+ (Digital blue + (Link 2))	C3	Analog blue
14	+5 Vdc (Power for monitor when in standby)	C4	Analog horizontal sync
TMDS = Transition Minimized Differential Signaling		C5	Analog ground (Return for R, G and B signals)

Serial line adapter

This is a commercial adapter. It allows you to connect four RS-232 serial lines to a common socket on the computer.

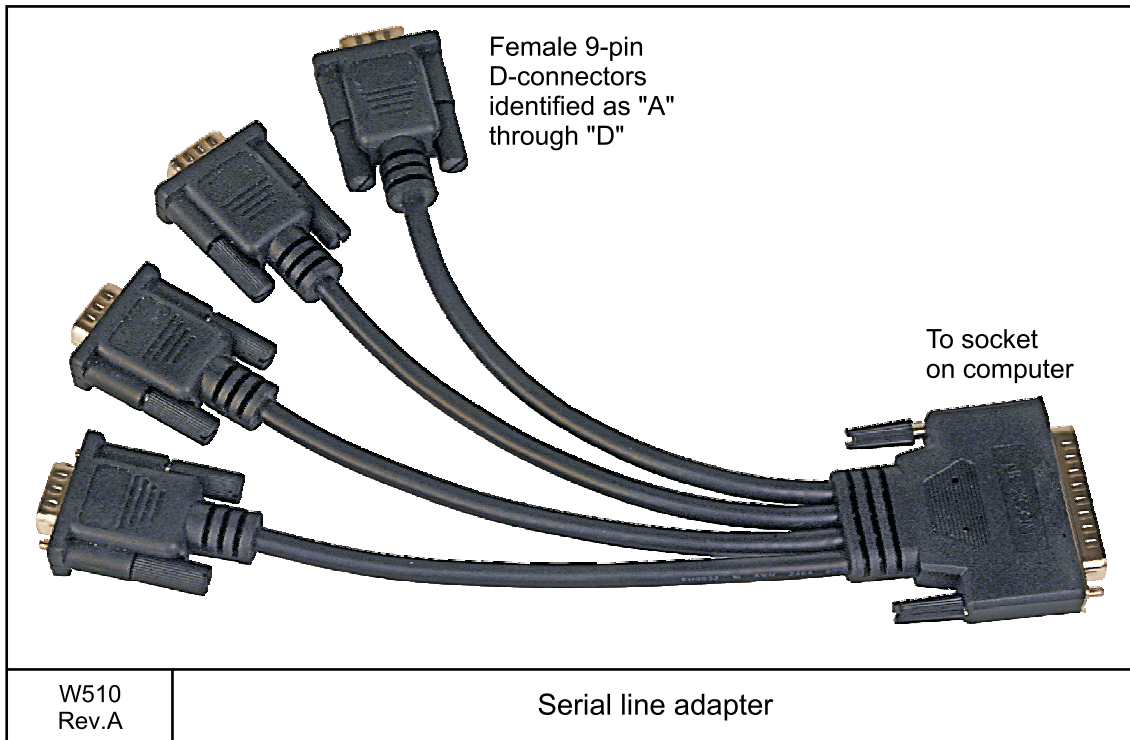

Cable specifications

- Not applicable

GPT remote on/off

This cable is used to connect a remote on/off switch to the General Purpose Transceiver (GPT). The switch can be located in a separate box manufactured by the installation shipyard, or incorporated on a common switch panel.

Remote power on/off when a single transceiver is used

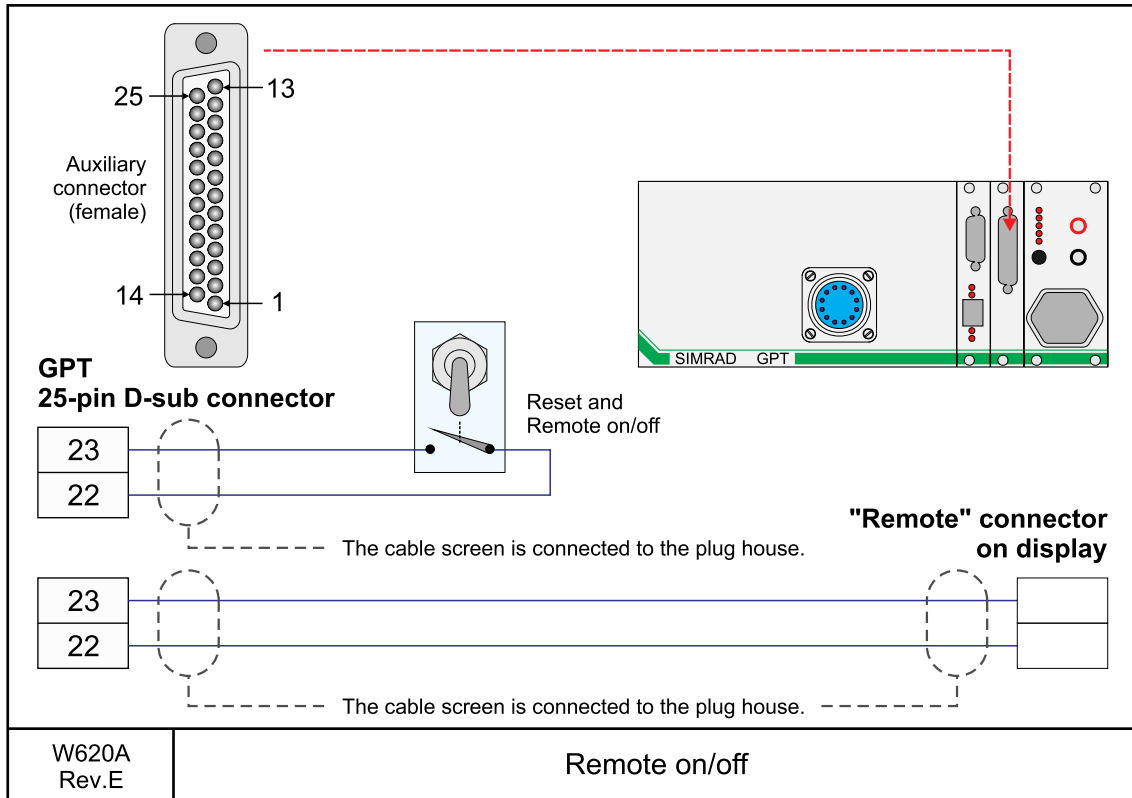

Cable specifications

- Conductors: 2 x 0.22 mm²
- Screen: Overall braided
- Voltage: 60 V
- Maximum diameter: Defined by the plugs

Remote power on/off when multiple transceivers are used

When multiple transceivers are used, two wiring options are available:

- You can switch all transceivers off and on simultaneously using a single switch.
- You can use one switch for each transceiver and switch power on and off individually.

Both options are illustrated below using five transceivers as an example.

Figure 15 Single switch

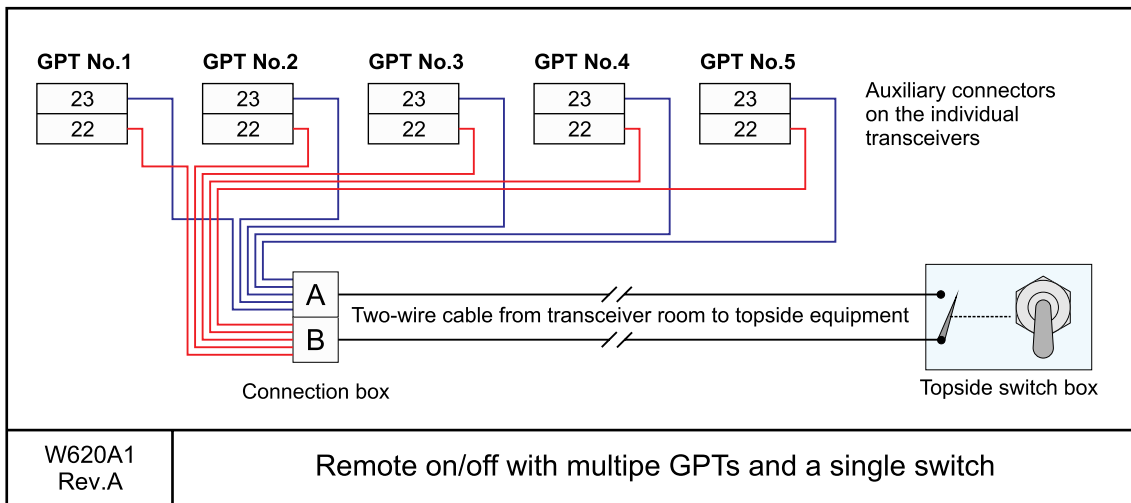
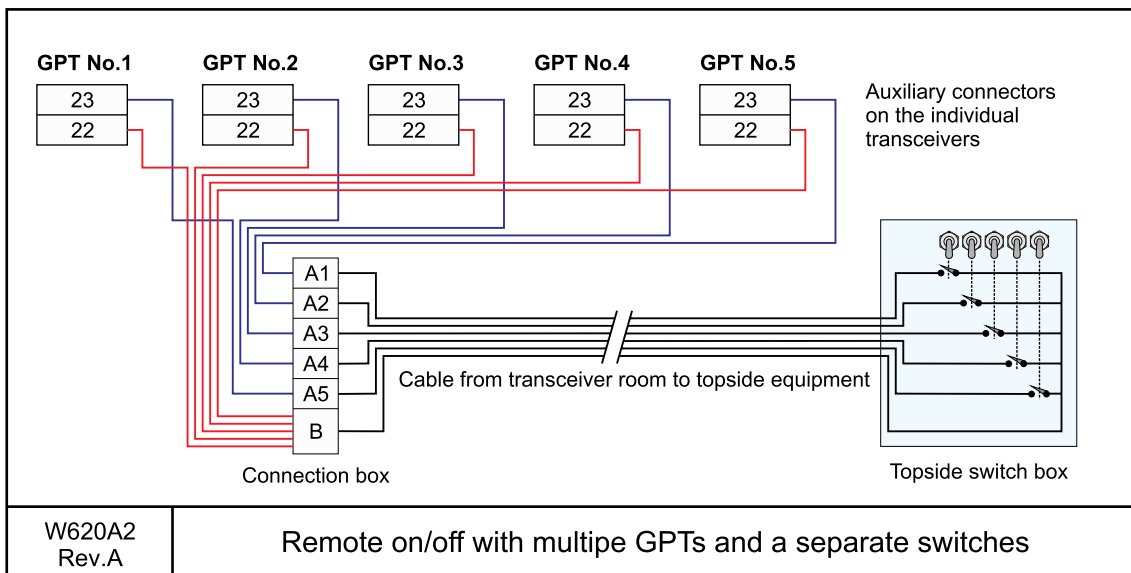
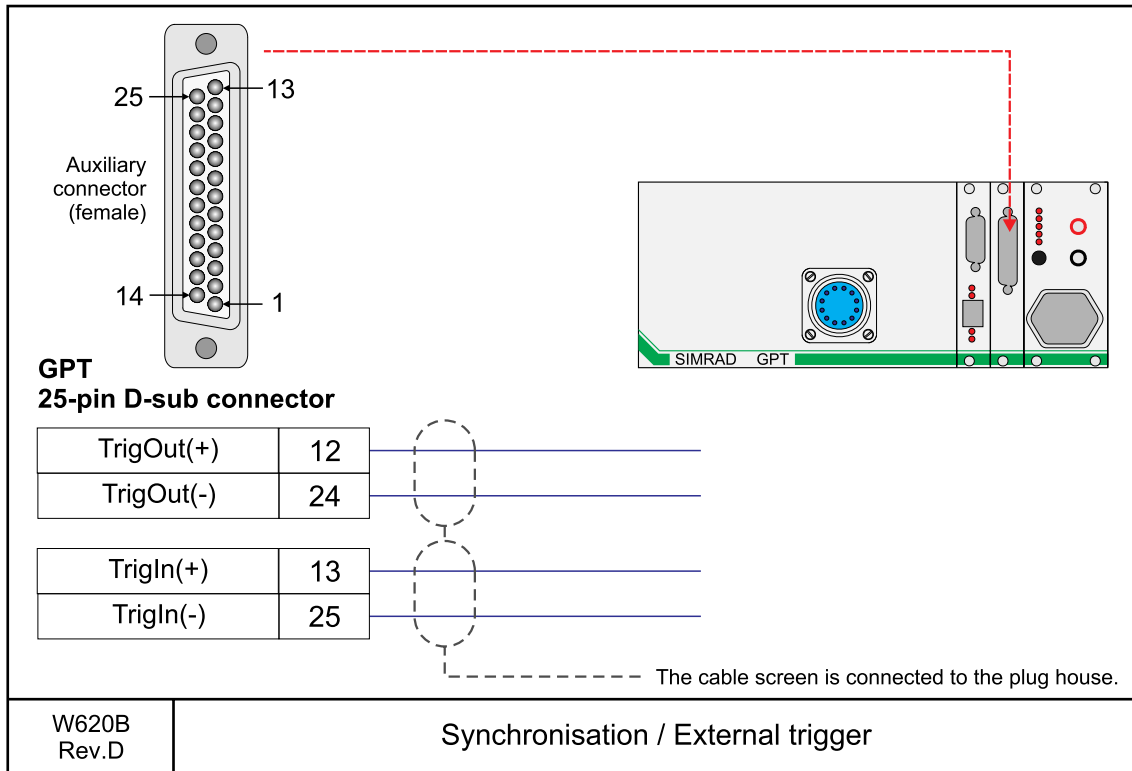

Figure 16 Individual switches



GPT trigger / synchronisation

This cable is used to connect the General Purpose Transceiver (GPT) to an external system for synchronisation purposes. It connects to the 25-pin D-sub connector on the front side of the GPT.



Cable specifications

- Conductors: 2 x 2 x 0.22 mm²
- Screen: Braided pairs and overall braided
- Voltage: 60 V
- Maximum diameter: Defined by the plugs

GPT battery

This cable is used to connect a battery to the General Purpose Transceiver (GPT). Red plug and red socket is normally used for positive (+). Black plug and black socket is normally used for negative (-).

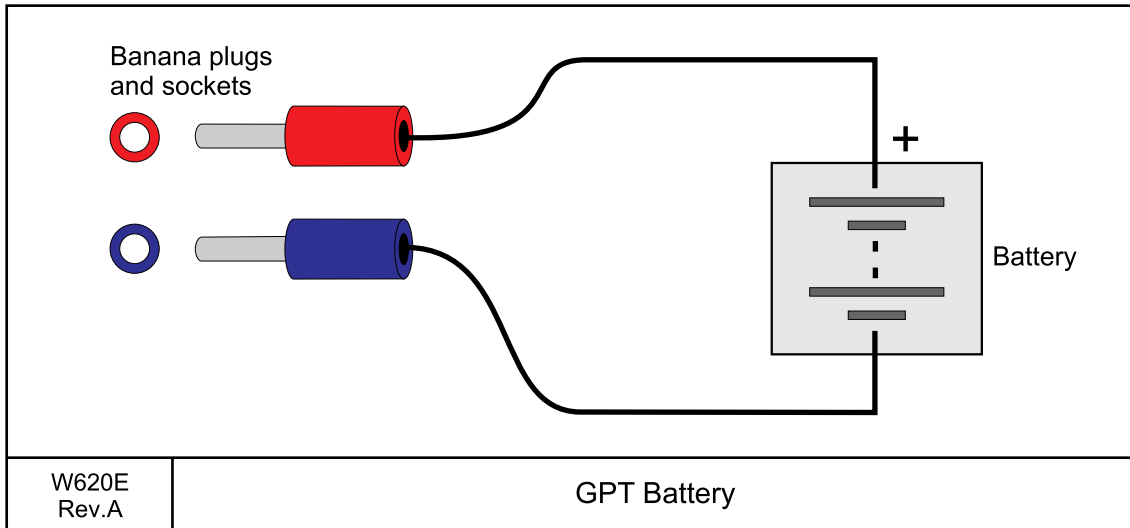

Cable specifications

- Conductors: 2 x 1.5 mm²
- Screen: N/A
- Voltage: Select to fit battery voltage
- Maximum diameter: N/A

ITI serial line

This cable is used to provide a two-way communication to a Simrad ITI Trawl system.

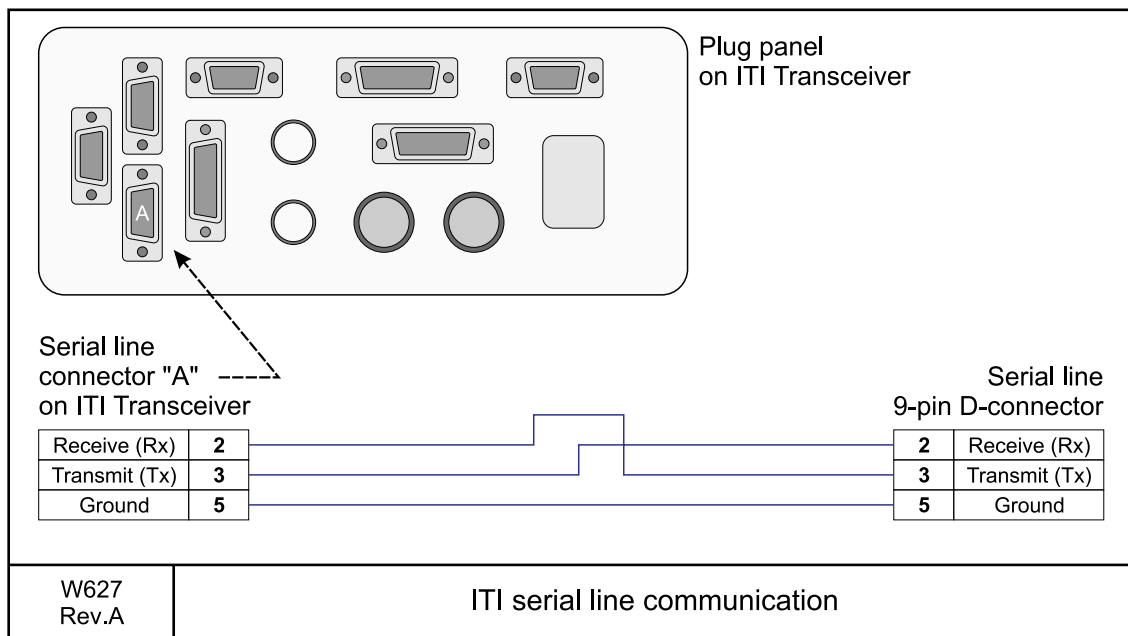

Cable specifications

- **Conductors:** 9 x 2 x 0.5 mm²
- **Screen:** Screened twisted pairs and overall braided
- **Voltage:** 60 V
- **Maximum diameter:** Limited by the plugs

PI44/54 serial line

This cable is used to provide a two-way communication to a Simrad PI44 or PI54 catch monitoring system.

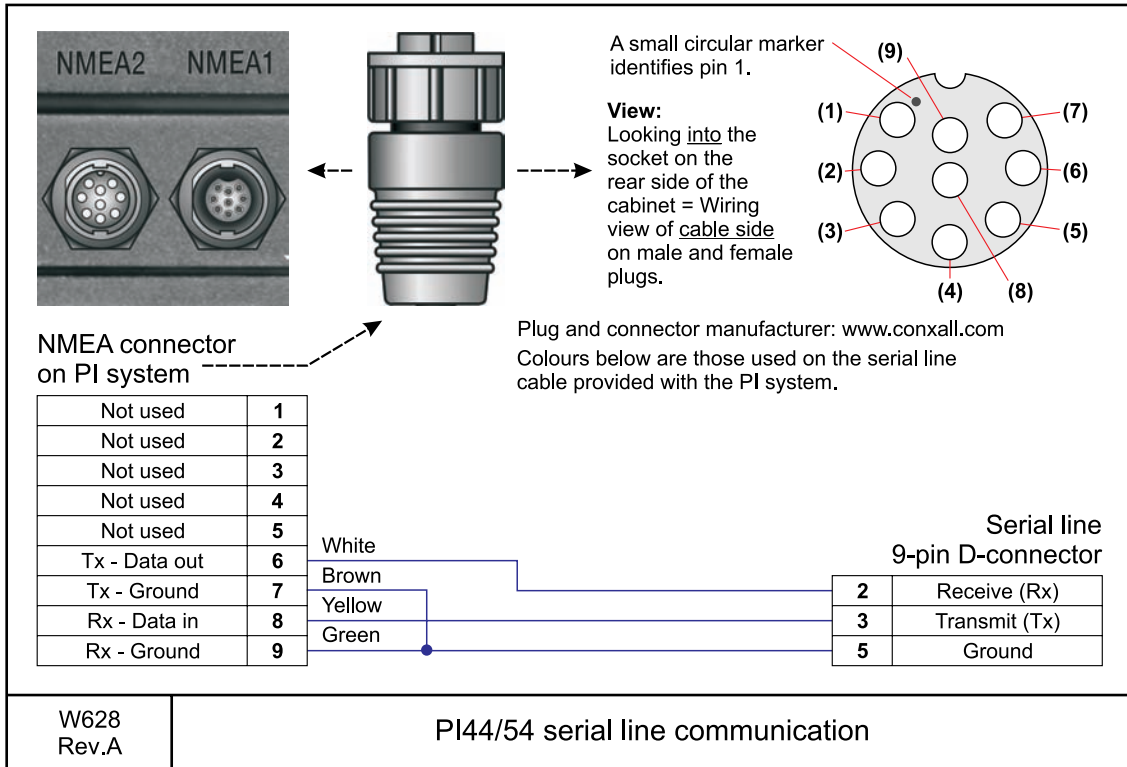

Cable specifications

- **Conductors:** 9 x 2 x 0.5 mm²
- **Screen:** Screened twisted pairs and overall braided
- **Voltage:** 60 V
- **Maximum diameter:** Limited by the plugs

PI30/32 serial line

This cable is used to provide a two-way communication to a Simrad PI30 or PI32 catch monitoring system.

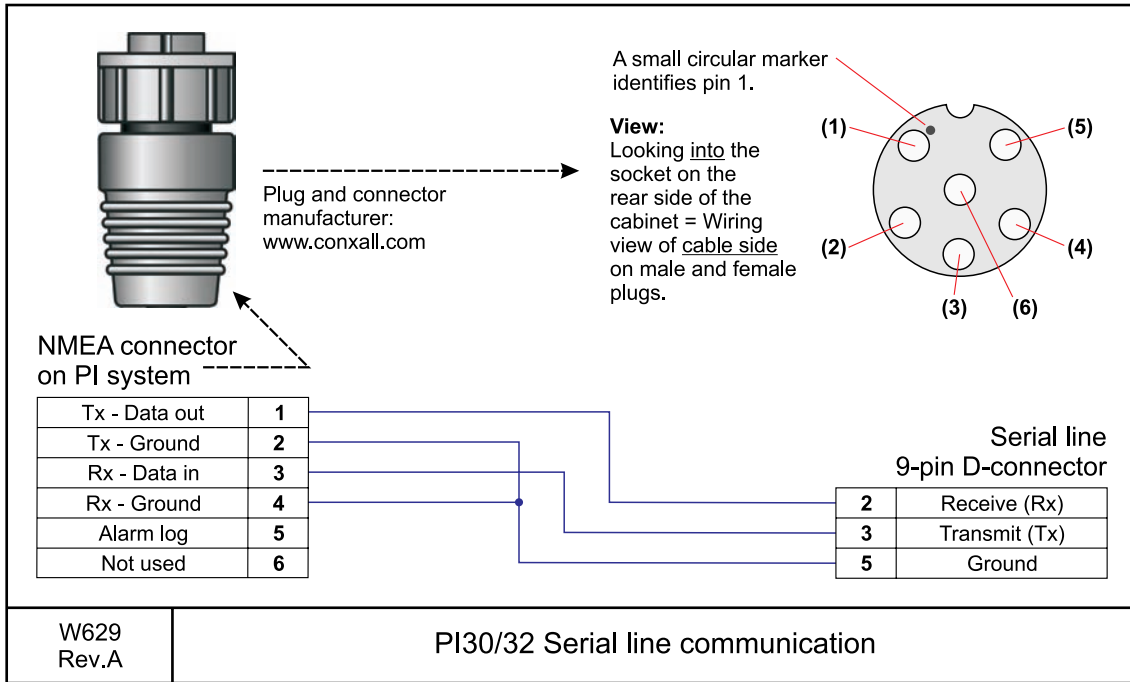

Cable specifications

- **Conductors:** 9 x 2 x 0.5 mm²
- **Screen:** Screened twisted pairs and overall braided
- **Voltage:** 60 V
- **Maximum diameter:** Limited by the plugs

Sonar serial line

This cable is used to provide a two-way communication to a sonar system using an Interface Unit.

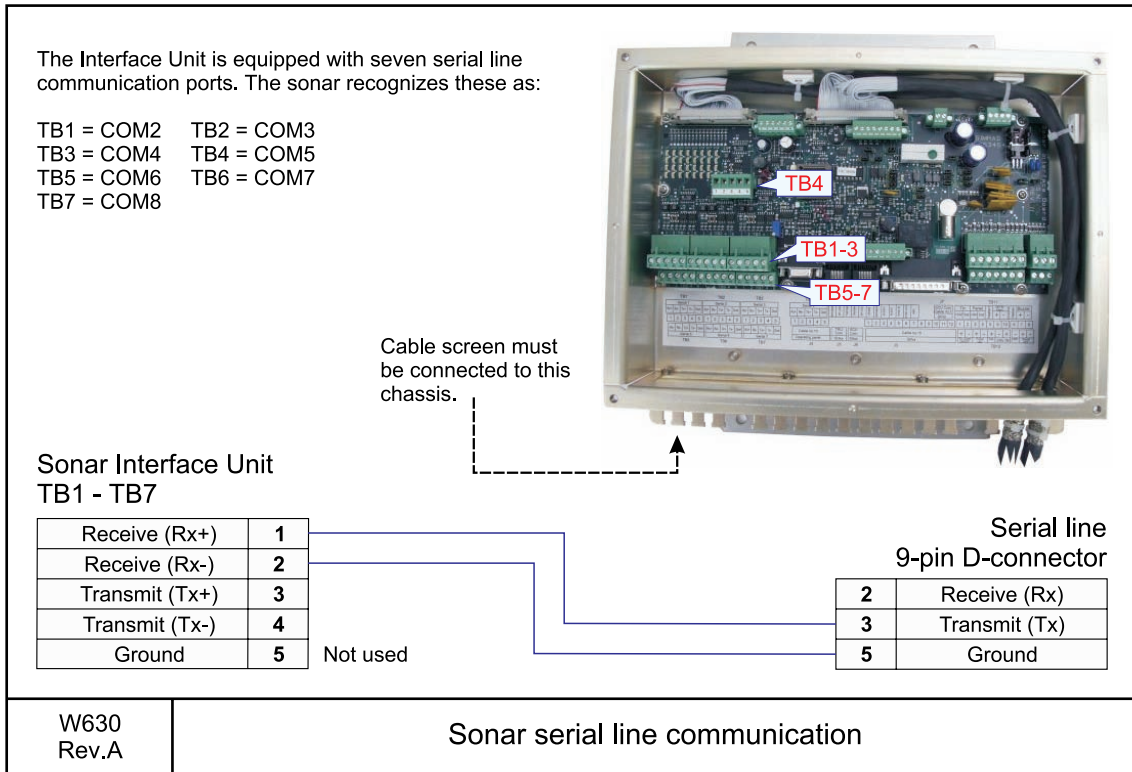

Cable specifications

- **Conductors:** 9 x 2 x 0.5 mm²
- **Screen:** Screened twisted pairs and overall braided
- **Voltage:** 60 V
- **Maximum diameter:** Limited by the plugs

Single beam/normal power transducer

This is the termination of the transducer cable from a single frequency, single beam transducer to the transducer socket on the General Purpose Transceiver Unit (GPT). The other end of the cable is permanently fixed to the transducer.

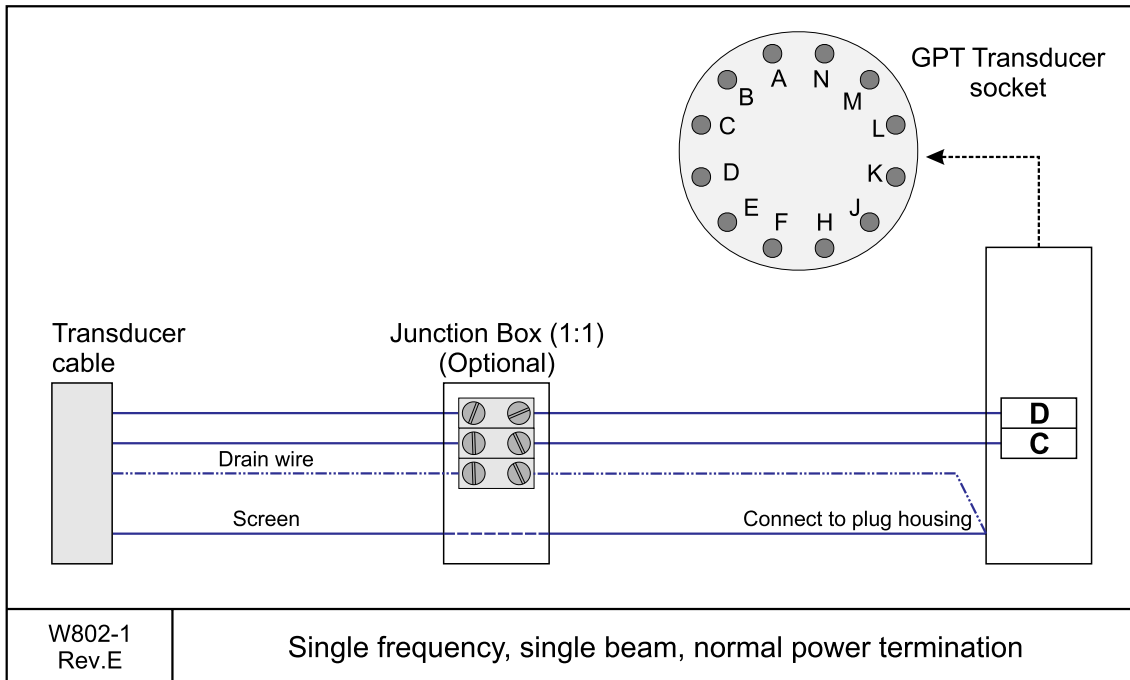

If you need to splice the transducer cable, it is very important to use the correct cable, and to avoid ground loops. We strongly recommend the use of a junction box. We also recommend that you install the transducer cable in a steel conduit.

For more information, see:

- *Transducer cable splicing* on page 142
- *Steel conduit* on page 142
- *GPT Transducer plug connection* on page 107

Single beam/high power transducer

This is the termination of the transducer cable from a single frequency, single beam transducer to the transducer socket on the General Purpose Transceiver Unit (GPT). The other end of the cable is permanently fixed to the transducer.

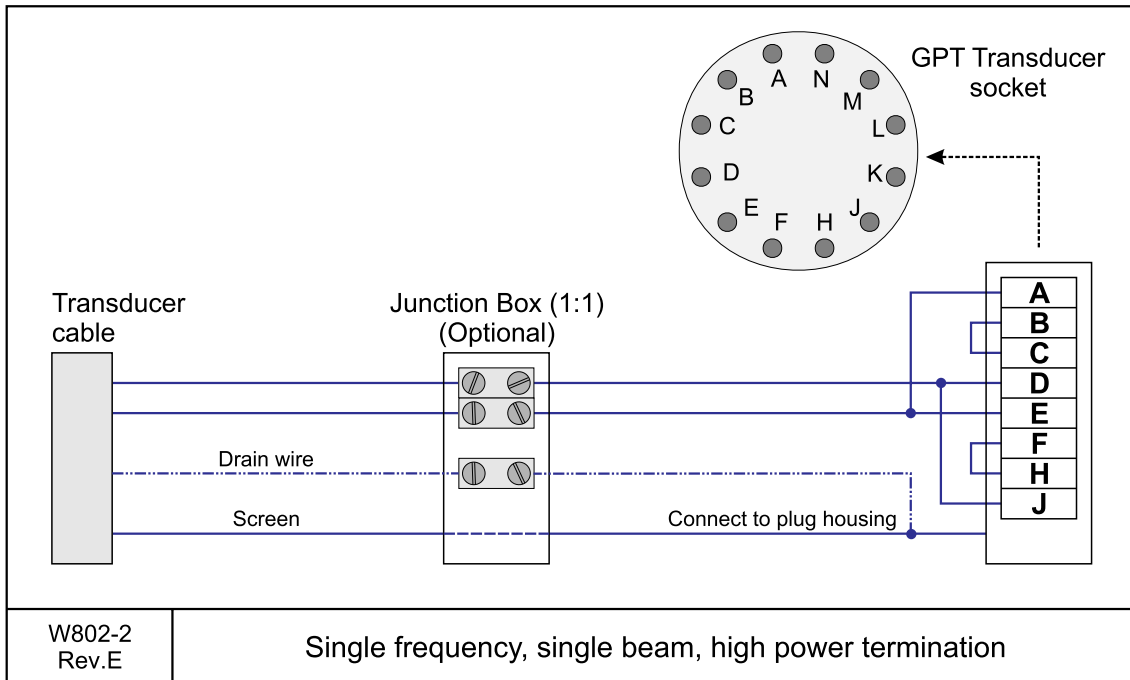

If you need to splice the transducer cable, it is very important to use the correct cable, and to avoid ground loops. We strongly recommend the use of a junction box. We also recommend that you install the transducer cable in a steel conduit.

For more information, see:

- *Transducer cable splicing* on page 142
- *Steel conduit* on page 142
- *GPT Transducer plug connection* on page 107

Dual beam (wide or narrow) transducer

This is the termination of the transducer cable from a single frequency, dual beam transducer to the transducer socket on the General Purpose Transceiver Unit (GPT). The other end of the cable is permanently fixed to the transducer.

Note

Always check the transmit power if wide beam is selected in order not to exceed the power capacity on the transducer.

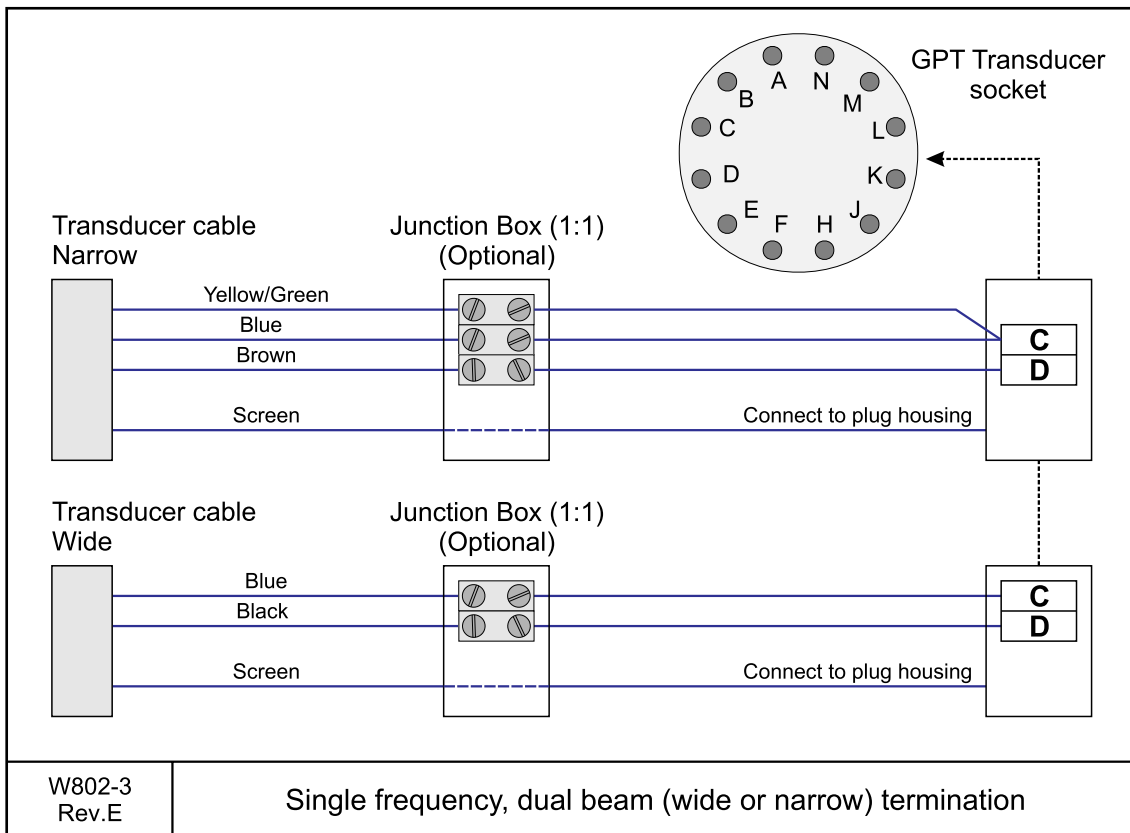

If you need to splice the transducer cable, it is very important to use the correct cable, and to avoid ground loops. We strongly recommend the use of a junction box. We also recommend that you install the transducer cable in a steel conduit.

For more information, see:

- *Transducer cable splicing* on page 142
- *Steel conduit* on page 142
- *GPT Transducer plug connection* on page 107

Split beam transducer

This is the termination of the transducer cable from a single frequency, split beam transducer to the transducer socket on the General Purpose Transceiver Unit (GPT). The other end of the cable is permanently fixed to the transducer.

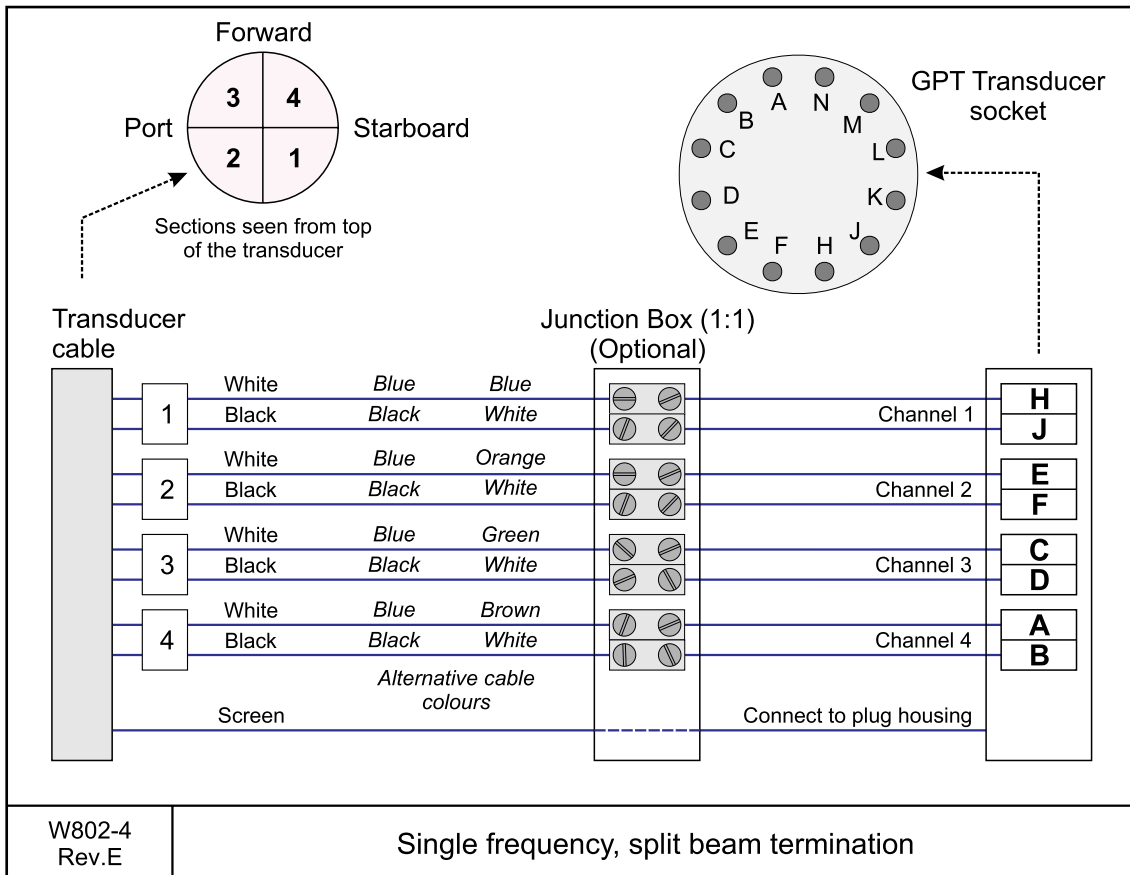

If you need to splice the transducer cable, it is very important to use the correct cable, and to avoid ground loops. We strongly recommend the use of a junction box. We also recommend that you install the transducer cable in a steel conduit.

For more information, see:

- *Transducer cable splicing* on page 142
- *Steel conduit* on page 142
- *GPT Transducer plug connection* on page 107

Split beam transducer to single beam transceiver

This is the termination of the transducer cable from a single frequency, split beam transducer - wired as a single beam transducer - to the socket on the General Purpose Transceiver Unit (GPT). The other end of the cable is permanently fixed to the transducer.

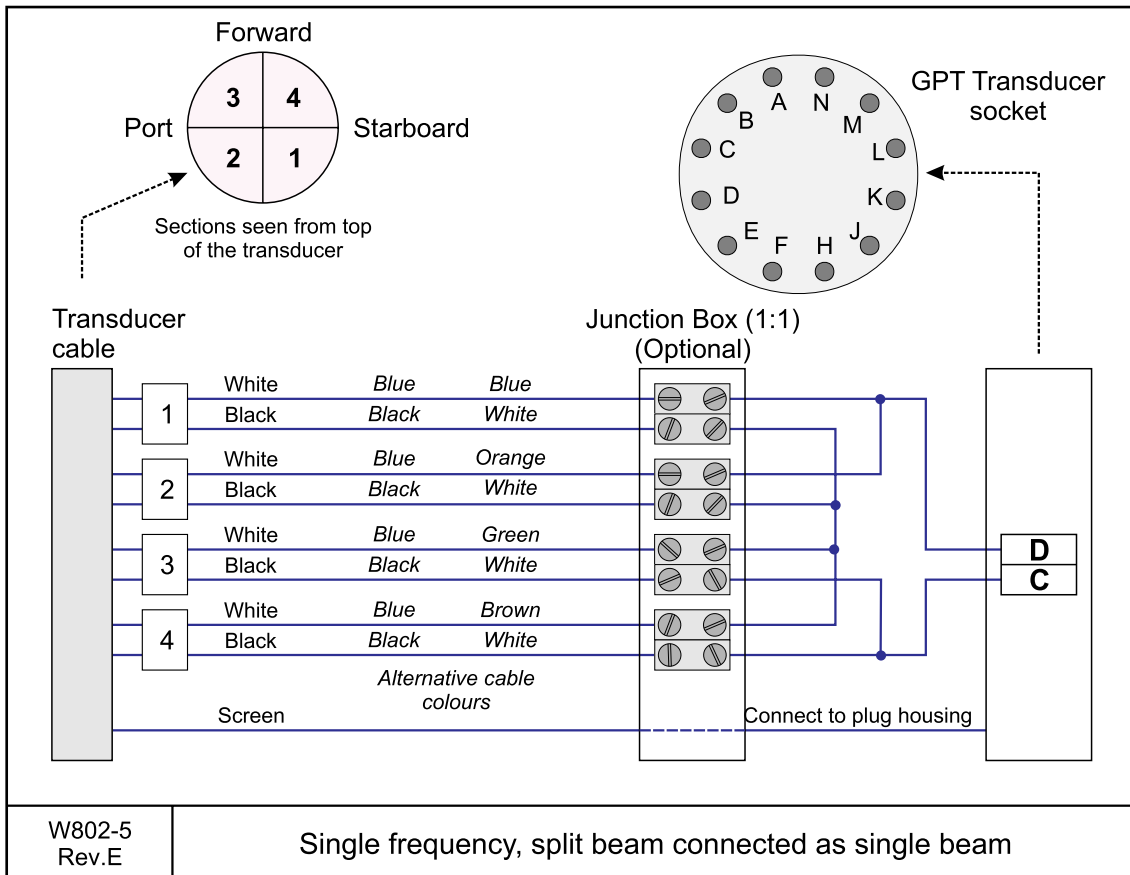

If you need to splice the transducer cable, it is very important to use the correct cable, and to avoid ground loops. We strongly recommend the use of a junction box. We also recommend that you install the transducer cable in a steel conduit.

For more information, see:

- *Transducer cable splicing* on page 142
- *Steel conduit* on page 142
- *GPT Transducer plug connection* on page 107

Dual frequency, single beam transducer

This is the termination of the transducer cable from a dual frequency, single beam transducer to the socket on the General Purpose Transceiver Unit (GPT). The other end of the cable is permanently fixed to the transducer.

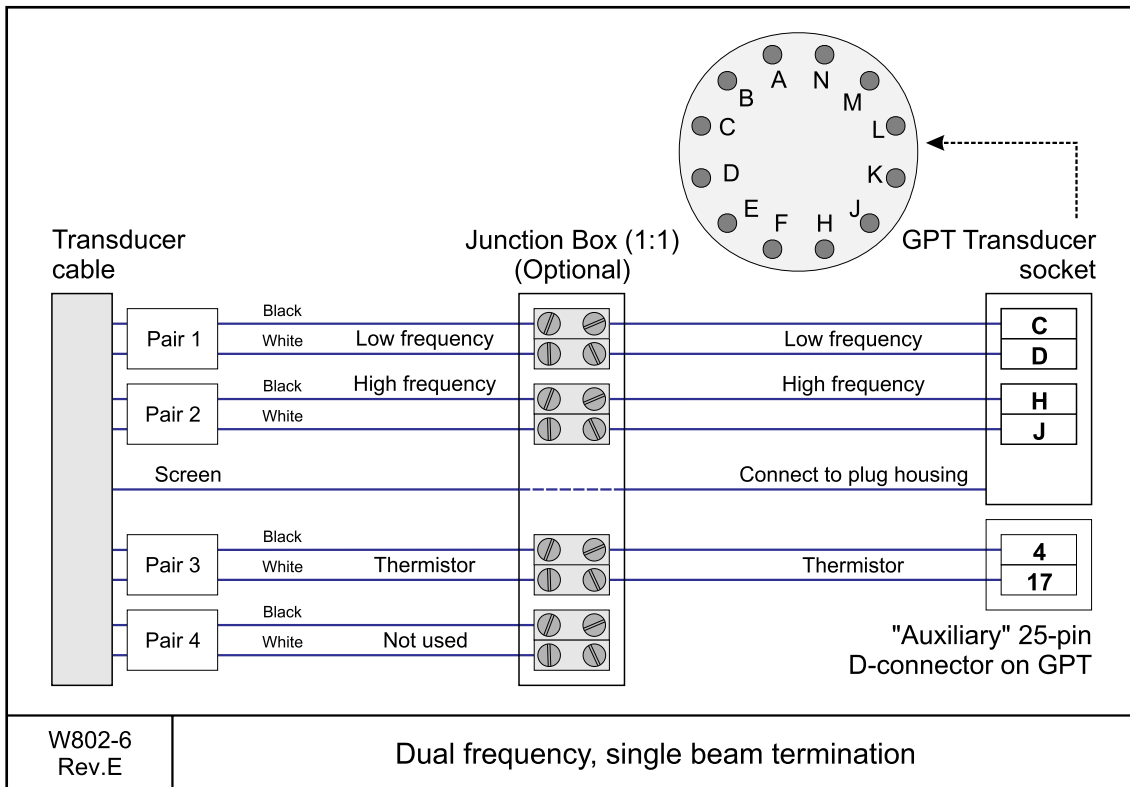

If you need to splice the transducer cable, it is very important to use the correct cable, and to avoid ground loops. We strongly recommend the use of a junction box. We also recommend that you install the transducer cable in a steel conduit.

For more information, see:

- *Transducer cable splicing* on page 142
- *Steel conduit* on page 142
- *GPT Transducer plug connection* on page 107

ES38–10 transducer

This is the termination of the transducer cable from the ES38–10 split-beam transducer to the transducer socket on the ES60 and EK60 General Purpose Transceiver Unit (GPT). The other end of the cable is permanently fixed to the transducer.

There are four pairs in the transducer cable, each with one black and one white cable. Each pair is marked with a small label identifying the transducer section. Pair number 4 is not used.

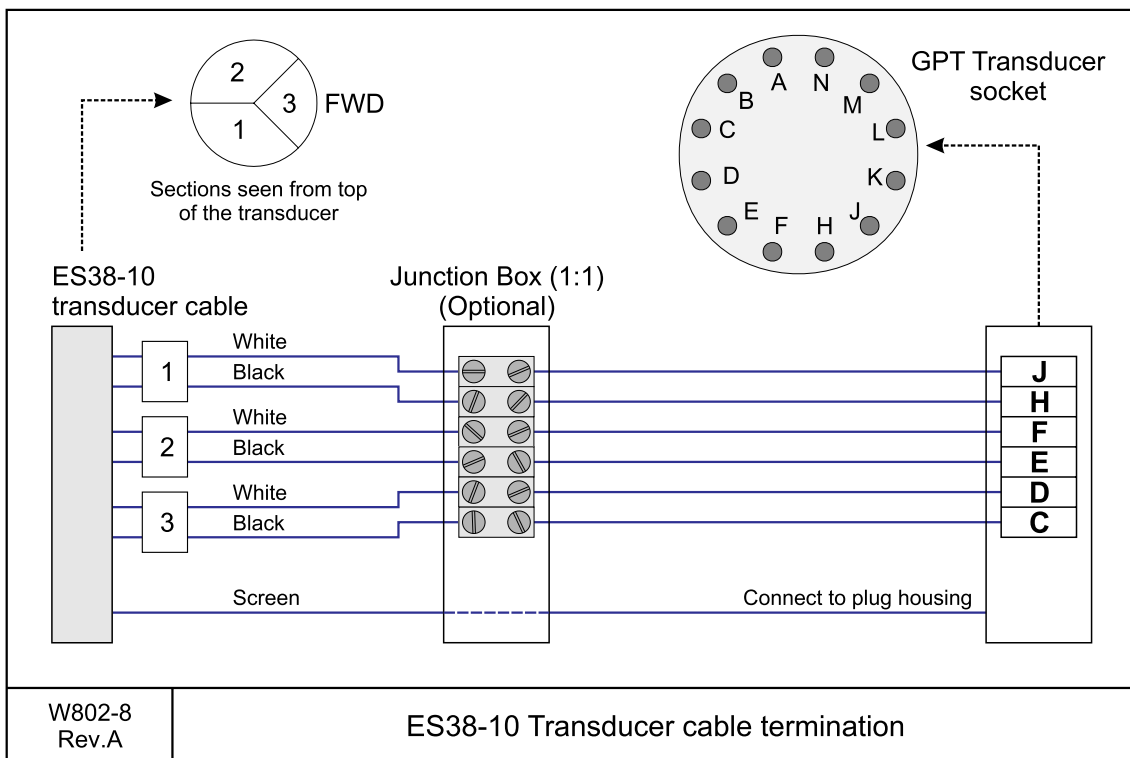

If you need to splice the transducer cable, it is very important to use the correct cable, and to avoid ground loops. We strongly recommend the use of a junction box. We also recommend that you install the transducer cable in a steel conduit.

For more information, see:

- *Transducer cable splicing* on page 142
- *Steel conduit* on page 142
- *GPT Transducer plug connection* on page 107

Single beam transducer to split beam transceiver

This is the termination of the transducer cable from a single frequency, single beam transducer to the socket on a split beam General Purpose Transceiver Unit (GPT). The other end of the cable is permanently fixed to the transducer.

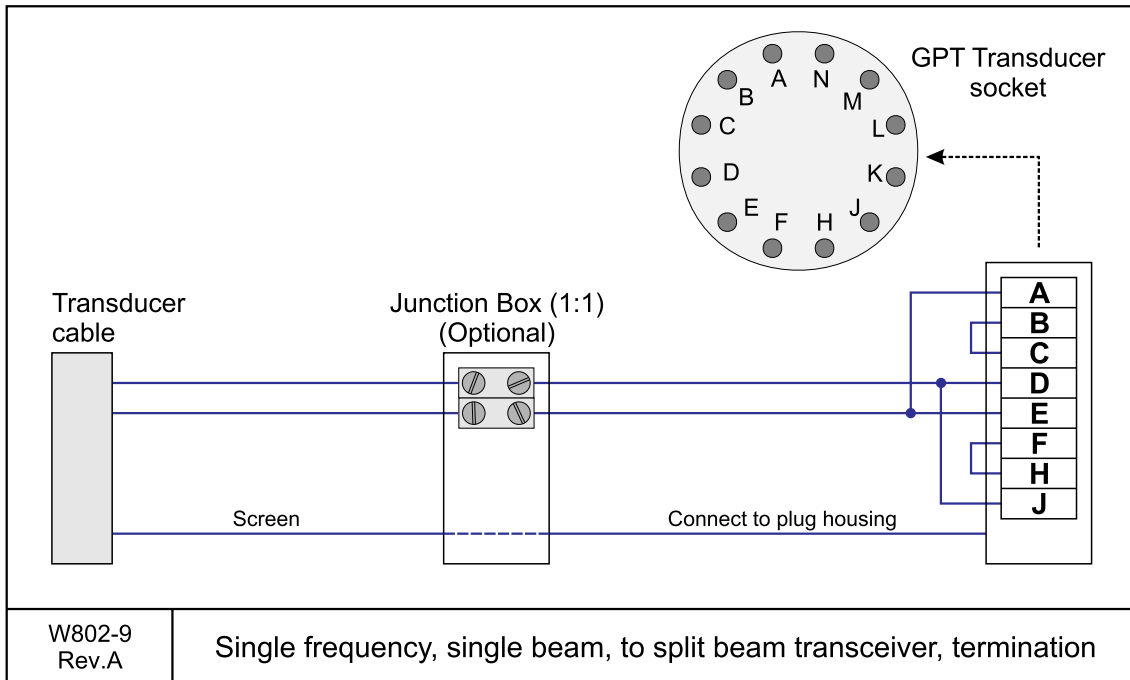

If you need to splice the transducer cable, it is very important to use the correct cable, and to avoid ground loops. We strongly recommend the use of a junction box. We also recommend that you install the transducer cable in a steel conduit.

For more information, see:

- *Transducer cable splicing* on page 142
- *Steel conduit* on page 142
- *GPT Transducer plug connection* on page 107

12-16/60 transducer

This is the termination of the transducer cable from the 12–16/60 single or dual beam transducer to the transducer socket on the General Purpose Transceiver Unit (GPT). The other end of the cable is permanently fixed to the transducer.

Note

Always check the transmit power if wide beam is selected in order not to exceed the power capacity on the transducer.

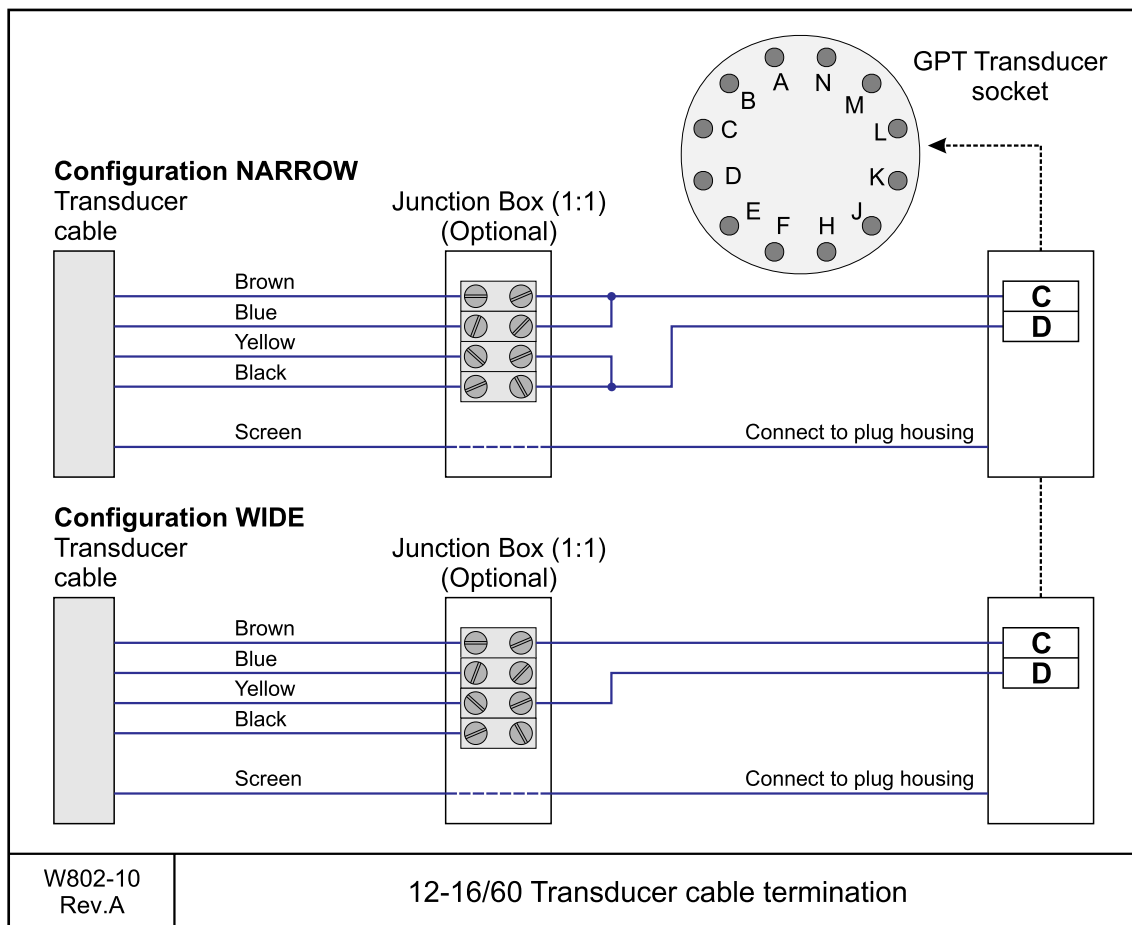

If you need to splice the transducer cable, it is very important to use the correct cable, and to avoid ground loops. We strongly recommend the use of a junction box. We also recommend that you install the transducer cable in a steel conduit.

For more information, see:

- *Transducer cable splicing* on page 142
- *Steel conduit* on page 142
- *GPT Transducer plug connection* on page 107

Deep water, split beam transducer

This is the termination of the transducer cable from a deep water transducer. This transducer is designed to be used towed bodies. The cable is equipped with a watertight connector. The other end of the cable is permanently fixed to the transducer.

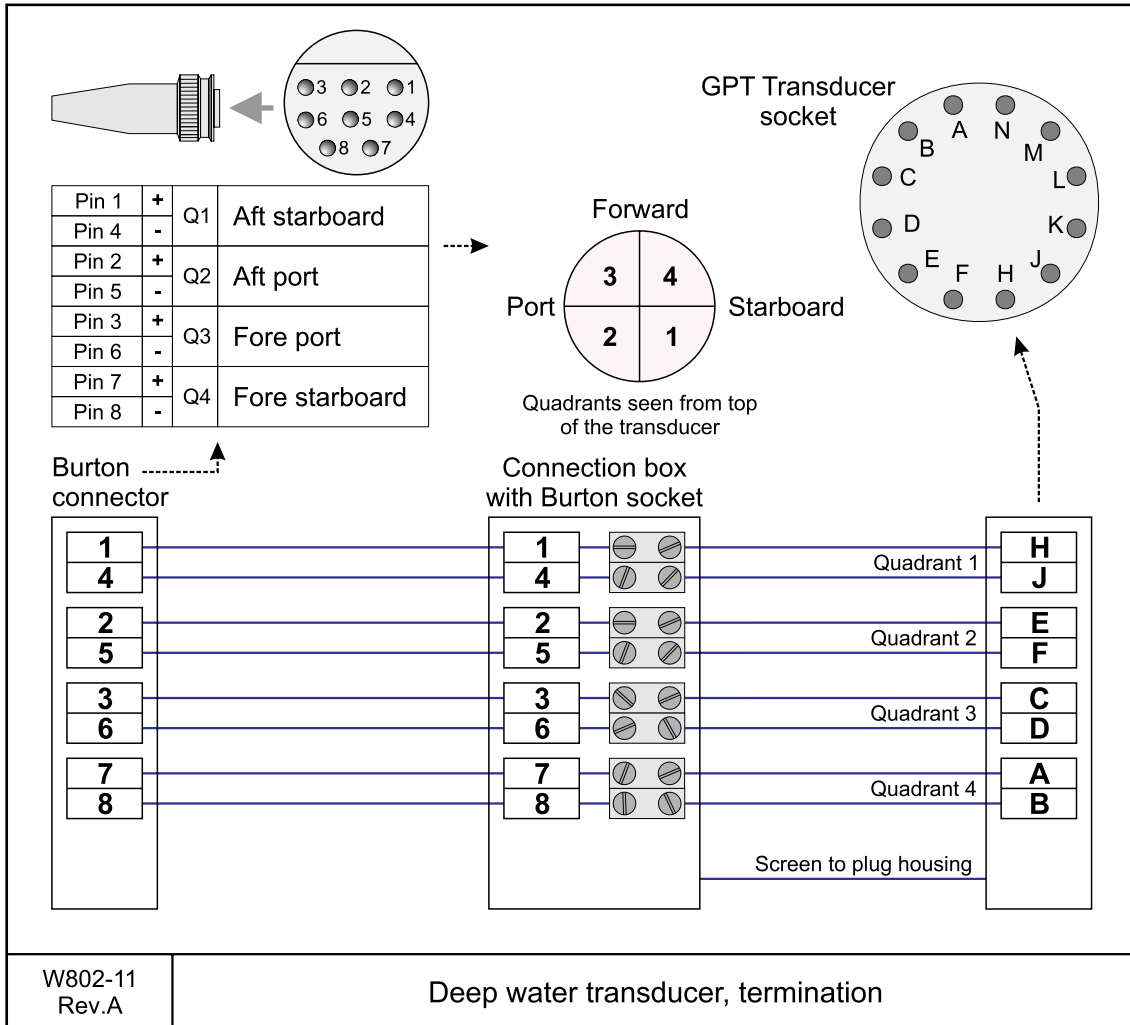

If you need to splice the transducer cable, it is very important to use the correct cable, and to avoid ground loops. We strongly recommend the use of a junction box. We also recommend that you install the transducer cable in a steel conduit.

For more information, see:

- *Transducer cable splicing* on page 142
- *Steel conduit* on page 142
- *GPT Transducer plug connection* on page 107

50/200 Combi C transducer

This is the termination of the transducer cable from the **Simrad 50/200 Combi C** transducer. The transducer cable is terminated in a Mini-Con-X connector manufactured by Conxall (www.conxall.com). The other end of the cable is permanently fixed to the transducer.

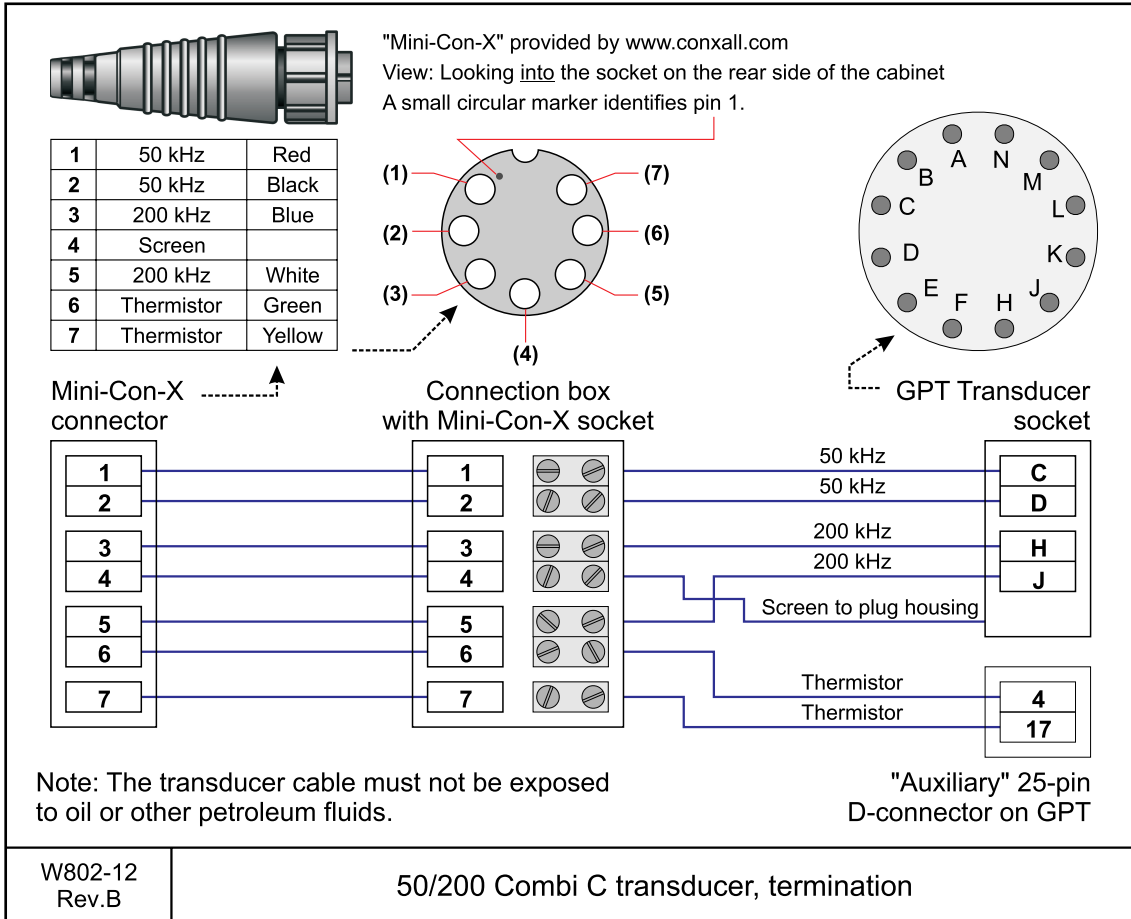

If you need to splice the transducer cable, it is very important to use the correct cable, and to avoid ground loops. We strongly recommend the use of a junction box. We also recommend that you install the transducer cable in a steel conduit.

For more information, see:

- *Transducer cable splicing* on page 142
- *Steel conduit* on page 142
- *GPT Transducer plug connection* on page 107

38/200 Combi C transducer

This is the termination of the transducer cable from the **Simrad 38/200 Combi C** transducer. The transducer cable is terminated in a Mini-Con-X connector manufactured by Conxall (www.conxall.com). The other end of the cable is permanently fixed to the transducer.

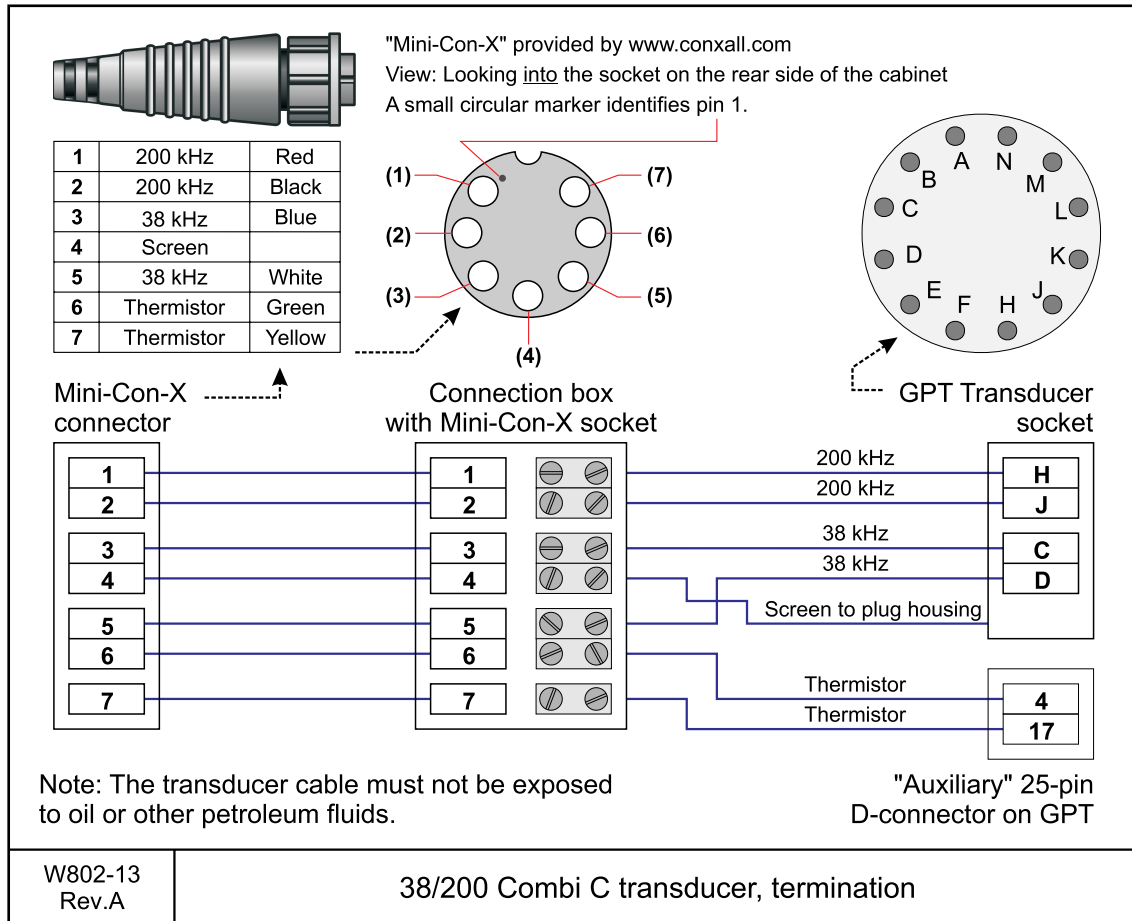

If you need to splice the transducer cable, it is very important to use the correct cable, and to avoid ground loops. We strongly recommend the use of a junction box. We also recommend that you install the transducer cable in a steel conduit.

For more information, see:

- *Transducer cable splicing* on page 142
- *Steel conduit* on page 142
- *GPT Transducer plug connection* on page 107

Software installation

This chapter describes how to install the ES70 software, how to upgrade, how to obtain a software license, and finally how to remove the software installation.

Topics

- *How to install the ES70 software* on page 76
- *How to obtain the ES70 license* on page 77
- *How to upgrade the ES70 software* on page 77
- *How to remove the ES70 software* on page 78

How to install the ES70 software

Use this procedure if you need to install the software on a new computer. Note that minimum hardware and software requirements must be met by the computer.

- 1 Power up the computer.
- 2 Insert the ES70 CD-ROM.
- 3 Observe that the installation program opens.
If the installation program does not start automatically, use a file manager to access the CD folder. Double-click on the **Setup.exe** file to start the installation.
- 4 Allow the ES70 installation to run. Follow the instructions provided.
- 5 Once the installation has been completed, double-click the ES70 icon on the desktop to start the application.

When the ES70 starts, you may see a dialog requesting permission to upgrade the firmware on the transceiver. This happens if the firmware on the transceiver is older than the firmware provided as a part of the ES70 software. Since functionality on the ES70 may depend on the firmware in the transceiver, click **Yes** to upgrade the transceiver.

- 6 If you use **Windows 7** operating system:
 - a Observe that **Windows 7 Firewall** will open a dialog requesting information about the network.
 - b Select *Public*, and click **Allow access**.
- 7 Observe the start-up procedure in the *Getting started* chapter.

This chapter is provided in the *ES70 Operator manual* and *ES70 Reference manual*.

How to obtain the ES70 license

The ES70 requires a valid license to operate. Without a license you will not be able to communicate with the transceiver.

Note

If you replace your computer, or if you replace major components inside your computer, you will need a new license code.

- 1 Double-click the ES70 icon on the desktop to start the application.
- 2 Click the **Setup** icon under the **Main** menu to open the **Setup** sub-menu.



- 3 Click **Installation** to open the **Installation** sub-menu.



On the sub-menu, click **Software License** to open the **Software License** dialog.



- 4 Write down the **Hardware ID** provided by the **Software License** dialog.
- 5 Contact your dealer to order the software license.
Your dealer will need the following information from you to place the order:
 - Vessel name and call sign
 - Vessel type (trawler, purse seiner, etc.)
 - Vessel owner's name, address and contact information
 - Serial number on all transceivers
 - Hardware ID
- 6 When the software license is returned, start the ES70, open the **Software License** dialog, and click **Enter Licence String**.
- 7 Write down the code, and click **Ok**.
- 8 Click **OK** to save the current settings and close the dialog.

How to upgrade the ES70 software

Use this procedure if you wish to reinstall the software, or receive a new CD-ROM with a software upgrade.

- 1 Observe the procedure for software installation.

Unless you have made any hardware changes on your computer, the existing software license will be used.

How to remove the ES70 software

Use this procedure if you need to remove all the ES70 software from the computer. Note that all data in the ES70 directory will be erased.

- 1 Observe the operating system's functionality for software removal.

Connecting the transceiver

This chapter explains how to connect the ES70 computer to the transceiver, and how to set up the frequency channels.

Each transceiver contains one or more frequency channels. The phrase is used to identify the combination of a transceiver, transducers and the frequencies offered. Split beam transceivers contain only one channel each. The upper part of the **Transceiver Installation** dialog displays a list of frequency channels which either are, or have been, installed on the ES70. For each channel, a status label is provided.

Topics

- *General Purpose Transceiver (GPT) interface* on page 79
- *Administration of frequency channels* on page 80

General Purpose Transceiver (GPT) interface

The ES70 computer communicates with the General Purpose Transceiver using one or more Ethernet cables. The number and type of cables required depends on the system configuration. The following basic configurations exist:

- One transceiver: Use a “crossover” cable between the computer and the transceiver
- Two or more transceivers: Use “straight” cables between the computer and the Ethernet switch, and between the switch and the transceivers.

Wiring procedure, one transceiver

- 1 Locate the Ethernet port you wish to use on the computer.
- 2 Connect a “crossover” cable from the computer’s Ethernet socket to the socket on the General Purpose Transceiver.
→ *RJ45 Ethernet, crossover* on page 50

Wiring procedure, two or more transceivers

- 1 Locate the Ethernet port you wish to use on the computer.
- 2 Install an Ethernet switch.

- 3 Connect a “straight” cable from the computer’s Ethernet socket to the “uplink” socket on the Ethernet switch.
→ *RJ45 Ethernet, straight* on page 49
- 4 Connect “straight” cables from Ethernet switch’s remaining sockets to each of the General Purpose Transceivers.

Setup procedure

Note that you will only need to carry out this procedure if you set up an ES70 system using a locally purchased computer!

This procedure is valid for Microsoft Windows XP.

- 1 On the ES70, exit the echo sounder program, and access the **Desktop**.
- 2 Click the **Start** button in the bottom left corner of the desktop.
On the menu, select **Settings**, and then **Control Panel**.
- 3 On the **Control Panel**, select **Network connections**.
- 4 Double-click on **Local Area Connection** to open the **Local Area Connection Status** dialog.
- 5 At the bottom of the dialog, click **Properties**.
- 6 In the **Local Area Connection Properties** dialog, select **Internet Protocol (TCP/IP)**, and click **Properties**.
- 7 Observe that the **Internet Protocol (TCP/IP) Properties** dialog opens.
- 8 Click **Use the following IP address**, and enter IP address: **157.237.14.12**.
Observe that the *Subnet mask* and *Default gateway* addresses appear automatically. You do not need to change these.
- 9 Click **Ok** to exit the **Internet Protocol (TCP/IP) Properties** dialog.
- 10 Click **Ok** to exit the **Local Area Connection Properties** dialog.
- 11 Click **Close** to exit the **Local Area Connection Status** dialog.

Administration of frequency channels

Use the following procedures to install, modify or delete frequency channels from the echo sounder setup.

General Purpose Transceivers (GPT) units physically connected to the echo sounder’s Ethernet interface are identified automatically by the system. When you open the **Transceiver Installation** dialog from the **Setup** menu, a list will be provided. A single frequency transceiver occupies one entry in the list, and a dual frequency transceiver occupies two. Each entry is identified as a frequency channel, and the line displays the parameters for the channel. Entries in the frequency channel list are shown in black, green or red colour identifying its current status.

How to install a frequency channel

- 1 Click the **Setup** icon under the **Main** menu to open the **Setup** sub-menu.



- 2 Click **Installation** to open the **Installation** sub-menu.



On the sub-menu, click **Transceiver Installation** to open the **Transceiver Installation** dialog.



- 3 In the **Transceiver Installation** dialog, click **Browse**.

The ES70 will automatically search the network for available transceivers.

- 4 Observe that available frequency channels are listed in the dialog.

Each transceiver contains one or more frequency channels. The phrase is used to identify the combination of a transceiver, transducers and the frequencies offered. Split beam transceivers contain only one channel each. The upper part of the **Transceiver Installation** dialog displays a list of frequency channels which either are, or have been, installed on the ES70. For each channel, a status label is provided.

- **Busy:** The frequency channel is already in use, probably by another echo sounder on the same network. You can not connect to this channel.
- **Installed:** This frequency channel is connected to you ES70 system.
- **Lost:** This frequency channel can not be used.

- 5 Select a frequency channel that is available, and choose the correct transducer in the spin box.

Note

This is a critical task. You must ensure that the correct transducer is selected. If you connect the transceiver to a transducer that can not handle the power rating, it may be damaged beyond repair.

- 6 Observe that the status for the relevant frequency channels changes to *Installed*.
- 7 Click **OK** to save the current settings and close the dialog.

How to disconnect a frequency channel

- 1 Click the **Setup** icon under the **Main** menu to open the **Setup** sub-menu.



- 2 Click **Installation** to open the **Installation** sub-menu.



On the sub-menu, click **Transceiver Installation** to open the **Transceiver Installation** dialog.



- 3 Observe that current frequency channels are listed in the dialog.
Each transceiver contains one or more frequency channels. The phrase is used to identify the combination of a transceiver, transducers and the frequencies offered. Split beam transceivers contain only one channel each. The upper part of the **Transceiver Installation** dialog displays a list of frequency channels which either are, or have been, installed on the ES70. For each channel, a status label is provided.
 - **Busy**: The frequency channel is already in use, probably by another echo sounder on the same network. You can not connect to this channel.
 - **Installed**: This frequency channel is connected to you ES70 system.
 - **Lost**: This frequency channel can not be used.
- 4 On the frequency channel you wish to disconnect, set the transducer type to *None*.
- 5 Observe that the status for the relevant frequency channels changes to *Available*.
- 6 Click **OK** to save the current settings and close the dialog.

How to modify an IP address

The transceivers are provided by Simrad readily set up with a fixed Ethernet address and an IP address. If your ES70 uses two transceivers with identical frequencies, these will by default have different Ethernet addresses, but identical IP addresses. In order for your system to work, all transceivers must have unique IP addresses.

- 1 Click the **Setup** icon under the **Main** menu to open the **Setup** sub-menu.



- 2 Click **Installation** to open the **Installation** sub-menu.



On the sub-menu, click **Transceiver Installation** to open the **Transceiver Installation** dialog.



- 3 Observe that the current frequency channels are listed in the dialog.
- 4 Click once on the frequency channel you wish to modify.
- 5 Observe that the relevant transceiver parameters are shown in the **Transceiver Information** field

- 6 Sett the transducer(s) to *None*, and click **Apply**.
- 7 Click **Change IP Address** to open the **IP Address** dialog.

Note

*If you have two Ethernet cables connected to your computer, you may need to disconnect the Ethernet cable to the ship's network before the **Change IP Address** is available.*

- 8 Enter a new IP address

Tip

Change only the last digit in the IP address.

If you do have a keyboard connected to your ES70 system, click the **Keyboard** button at the bottom of the dialog to open an on-screen keyboard.

- 9 Click **OK** to save the current settings and close the dialog.
- 10 In the **Transceiver Installation** dialog, observe that the IP address for the chosen transceiver has changed.
- 11 Install the transducers for the channel with the new IP address.

Note

Make sure that you choose the correct transducer(s)!

- 12 Click **OK** to save the current settings and close the dialog.

Interfaces and integration

The Simrad ES70 computer provides one or more multi purpose serial and Ethernet ports for external interfaces.

Which interfaces to use, and how many, must be decided by considering the available serial lines on the computer and the need for integration with other hydroacoustic and navigation systems.

Topics

- *About NMEA interfaces and telegrams* on page 84
- *External interfaces* on page 85
 - *How to set up the Ethernet output interface* on page 86
 - *How to set up the Simrad ITI Trawl system interface* on page 87
 - *How to set up the Simrad PI Catch monitoring system interface* on page 88
 - *How to set up the sonar system interface* on page 90
 - *How to set up the navigation system interface* on page 90
 - *How to set up the motion sensor interface* on page 92
 - *How to set up the depth output* on page 93
 - *How to set up the annotation interface* on page 94
- *ES70 External triggering* on page 95
- *GPT Auxiliary connector* on page 99

About NMEA interfaces and telegrams

By means of the connectors on the ES70 computer, the echo sounder can communicate with several peripheral devices. This is useful, as it allows you to export and import information to and from these devices. In order to establish this communication, the devices on each end of the cable must speak the same “language”.

Related topics

- *Telegram formats* on page 160

NMEA

The *National Marine Electronics Association (NMEA)* has defined communication standards for maritime electronic equipment, and the ES70 echo sounder conforms to these standards. The most common standard is *NMEA 0183*, and the National Marine Electronics Association describes it as follows:

The NMEA 0183 Interface Standard defines electrical signal requirements, data transmission protocol and time, and specific sentence formats for a 4800 baud serial data bus. Each bus may have only one talker but many listeners.

— *National Marine Electronics Association*

For more information about the National Marine Electronics Association and the NMEA 0183 standard, refer to the organization's web site at:

<http://www.nmea.org>

Telegrams

To move information between two electronic units, the data are collected in **telegrams**. The content (protocol) of each telegram is defined by the NMEA standard, and several telegram types exist to allow different type of data to be distributed.

The phrase **datagram** is also frequently used about this communication method.

Unless you wish to write your own software, you do not need to know how these telegrams are designed. However, whenever you set up equipment interfaces, you need to ensure that each system on your communication line is set up to send and receive the same telegram. The standard allows one system to send data (a "talker") and several others to receive data simultaneously ("listeners") on the same line. Therefore, you must ensure that all products receiving data on a communication line is set up to receive the same telegram(s) that the transmitting product provides.

Standard NMEA 0183 communication parameters

The communication parameters defined for **NMEA 0183** are:

- **Baudrate:** 4800 bits per second
- **Data bits:** 8
- **Parity:** None
- **Stop bits:** One

Some instruments will also offer other parameters and/or choices.

External interfaces

The following interfaces are set up to transmit and/or receive information by means of Ethernet and/or serial lines.

How to set up the Ethernet output interface

The ES70 can communicate with an external devices that can benefit from the processed data. Such devices include the **Olex** chart plotter system. This communication is controlled by the **Ethernet Output** dialog.

The following telegrams may be exported:

- Parameter
- Vessel log
- Navigation
- Motion sensor
- Depth
- Echogram
- Echo trace

The interface will require the absolute identity of the remote UDP port and the remote IP address.

The settings required for the Olex system are specified in the **EK500 Datagram** dialog description in the *ES70 Reference Manual*.

Wiring procedure

- 1 Locate the Ethernet port you wish to use.
- 2 If no Ethernet port is available, an Ethernet switch may be inserted between the computer and the transceiver.
- 3 If you connect an Ethernet cable directly between the ES70 computer and a remote computer, you must use a Ethernet cable. If you connect the other computer by means of an Ethernet switch, you must use “straight” Ethernet cables.

Setup procedure

- 1 Click the **Setup** icon under the **Main** menu to open the **Setup** sub-menu.



- 2 Click **Ethernet Output** to open the **Ethernet Output** dialog.



- 3 Define the **Remote Port**.
- 4 Define the **Remote IP Address** for the computer you wish to export the information to.
- 5 Set **Communication Mode** to *Broadcast*.
- 6 In the **Ethernet Output** dialog, click **EK500 Datagram** to open the **EK500 Datagram** dialog.
- 7 On the **Datagram** tab, define which datagrams you wish to export.
- 8 Click **OK** to save the current settings and close the dialog.

Related topics

- *RJ45 Ethernet, straight* on page 49
- *RJ45 Ethernet, crossover* on page 50

How to set up the Simrad ITI Trawl system interface

Communication with the Simrad ITI (Integrated Trawl Instrumentation) is based on NMEA and proprietary telegrams.

Supported telegram formats

- *DBS Depth below surface* on page 161
- *DBS Depth of trawl below surface* on page 170
- *HFB Trawl headrope to footrope and bottom* on page 170

Wiring procedure for serial communication

- 1 Locate a free RS-232 serial port that can be used to connect the ITI system.
- 2 On the ES70 computer, connect the receive signal **Rx** on pin 2, the transmit signal **Tx** on pin 3, and **ground** on pin 5.
→ *Generic RS-232 Serial line* on page 42
- 3 On the ITI transceiver, use connector **Serial A**. Connect the receive signal **Rx** on pin 2, the transmit signal **Tx** on pin 3, and **ground** on pin 5.
→ *ITI serial line* on page 60
- 4 Ensure that the length of the cable does not exceed approximately 50 meters. If a longer cable is required, you may need to use buffer amplifiers on the serial line.

Setup procedure

This procedure explains how the ES70 can be set up to receive ITI information on a serial port.

- 1 Click the **Setup** icon under the **Main** menu to open the **Setup** sub-menu.



- 2 Click **Installation** to open the **Installation** sub-menu.



On the sub-menu **I/O Setup** to open the **I/O Setup** dialog.



- 3 In the **I/O Setup** dialog, select which serial line to use to accept ITI information.
- 4 Click on the chosen port to select it, then click the **Input** button to open the **Select Inputs** dialog.

- 5 In the **Select Inputs** dialog, locate the **ITI** on the left side, and click the [**>**] button to connect it.
 - **ITI**: This setting allows you to communicate with the Simrad ITI system. Values for trawl opening and distance must be entered manually in the **Trawl** dialog.

The following proprietary telegram formats are supported:

 - *DBS Depth below surface* on page 161
 - *DBS Depth of trawl below surface* on page 170
 - *HFB Trawl headrope to footrope and bottom* on page 170
- 6 Click **OK** to save the current settings and close the dialog.
- 7 In the **I/O Setup** dialog, click on the chosen port to select it, then click the **Setup** button to open the **Serial Setup** dialog.
- 8 In the **Serial Setup** dialog, enter the relevant parameters to set up the port.
- 9 Click **OK** to save the current settings and close the dialog.
- 10 In the **I/O Setup** dialog, click on the chosen port to select it, then click the **Monitor** button to open the **Port Monitor** dialog.

In order to monitor the data flow, the ITI system must be active and transmitting information to the ES70.
- 11 If the data flow is operational, close all dialogs.

How to set up the Simrad PI Catch monitoring system interface

Communication with the Simrad PI Family catch monitoring systems is based on NMEA and proprietary telegrams.

Supported telegram formats

- *DBS Depth below surface* on page 161
- *PSIMP.D PI Sensor data* on page 171

Wiring procedure for serial communication

- 1 Locate a free RS-232 serial port that can be used to connect the PI system.
- 2 On the ES70 computer, connect the receive signal **Rx** on pin 2, the transmit signal **Tx** on pin 3, and **ground** on pin 5.

→ *Generic RS-232 Serial line* on page 42
- 3 On PI44 and PI54, use either connector **NMEA1** or **NMEA2**. Connect the receive signal **Rx** on pin 8, the transmit signal **Tx** on pin 6, and **ground** on pins 7 and 9.

→ *PI44/54 serial line* on page 61
- 4 On PI30 and PI32, use connector **NMEA**. Connect the receive signal **Rx** on pin 3, the transmit signal **Tx** on pin 1, and **ground** on pins 2 and 4.

→ *PI30/32 serial line* on page 62

- 5 Ensure that the length of the cable does not exceed approximately 50 meters. If a longer cable is required, you may need to use buffer amplifiers on the serial line.

Setup procedure

This procedure explains how the ES70 can be set up to receive PI information on a serial port.

- 1 Click the **Setup** icon under the **Main** menu to open the **Setup** sub-menu.



- 2 Click **Installation** to open the **Installation** sub-menu.



On the sub-menu **I/O Setup** to open the **I/O Setup** dialog.



- 3 In the **I/O Setup** dialog, select which serial line to use to accept PI information.
- 4 Click on the chosen port to select it, then click the **Input** button to open the **Select Inputs** dialog.
- 5 In the **Select Inputs** dialog, locate the **PI50** on the left side, and click the [**>**] button to connect it.
 - **PI:** This setting allows you to communicate with one of the Simrad PI systems. Values for trawl opening and distance are provided by the system. The following proprietary telegram formats are supported:
 - *DBS Depth below surface* on page 161
 - *PSIMP.D PI Sensor data* on page 171
- 6 Click **OK** to save the current settings and close the dialog.
- 7 In the **I/O Setup** dialog, click on the chosen port to select it, then click the **Setup** button to open the **Serial Setup** dialog.
- 8 In the **Serial Setup** dialog, enter the relevant parameters to set up the port.
- 9 Click **OK** to save the current settings and close the dialog.
- 10 In the **I/O Setup** dialog, click on the chosen port to select it, then click the **Monitor** button to open the **Port Monitor** dialog.

In order to monitor the data flow, the PI system must be active and transmitting information to the ES70.
- 11 If the data flow is operational, close all dialogs.

How to set up the sonar system interface

The current depth from a defined transceiver channel can be sent out on a serial line to a sonar system. You can only use the serial lines already set up to accept input from other peripherals.

Note that the depth information is normally also provided on the duplex interfaces to trawl instrumentation and catch monitoring systems.

Wiring procedure

- 1 Locate the RS-232 serial port that can be used to connect the sonar system.
- 2 On the ES70 computer, connect the transmit signal **Tx** on pin 3, and **ground** on pin 5.
- 3 Sonar:
 - **Interface Unit:** Use one of the serial line connectors **TB1** through **TB7**. Connect the transmitted signal **Tx** from ES70 to pin 1, and **ground** on pin 5.
 - **Processor Unit:** Connect the transmitted signal **Tx** from ES70 to pin 2, and **ground** on pin 5.
- 4 Ensure that the length of the cable does not exceed approximately 50 meters. If a longer cable is required, you may need to use buffer amplifiers on the serial line.

Setup procedure

- 1 Click the **Setup** icon under the **Main** menu to open the **Setup** sub-menu.



- 2 Click **Depth Output** to open the **Depth Output** dialog.



- 3 Select which port to use.
- 4 For the selected port, click **Setup** to define the communication parameters.
- 5 Select which telegram to send.
- 6 If applicable, define the Talker ID.
- 7 Select which transceiver and frequency you wish to export the depth information from.

In most cases, the lowest frequency is used.

- 8 Click **OK** to save the current settings and close the dialog.

How to set up the navigation system interface

Most Global Positioning System (GPS) receivers provide NMEA 0183 telegrams containing speed, heading and sailed distance as well as geographical latitude and longitude.

Supported telegram formats for heading:

- *HDG Heading, deviation and variation* on page 164
- *HDT Heading, true* on page 165
- *HDM Heading, magnetic* on page 164
- *VHW Water speed and heading* on page 165

Supported telegram formats for distance

- *RMC Recommended minimum specific GNSS data* on page 165
- *VHW Water speed and heading* on page 165
- *VTG Course over ground & ground speed* on page 166

Supported telegram formats for positioning

- *GLL Geographical position latitude/longitude* on page 163
- *GGA Global positioning system fix data* on page 163
- *RMC Recommended minimum specific GNSS data* on page 165

Supported telegram formats for speed

- *RMC Recommended minimum specific GNSS data* on page 165
- *VHW Water speed and heading* on page 165
- *VTG Course over ground & ground speed* on page 166

Wiring procedure for serial communication

- 1 Locate a free RS-232 serial port that can be used to connect the navigation receiver.
- 2 On the ES70 computer, connect the receive signal **Rx** on pin 2, and **ground** on pin 5.
→ *Generic RS-232 Serial line* on page 42
- 3 On the GPS system, wire as described in the relevant documentation.
- 4 Ensure that the length of the cable does not exceed approximately 50 meters. If a longer cable is required, you may need to use buffer amplifiers on the serial line.

Setup procedure

- 1 Click the **Setup** icon under the **Main** menu to open the **Setup** sub-menu.



- 2 Click **Navigation** to open the **Navigation** dialog.

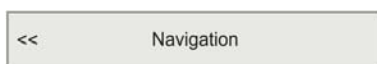

- 3 For each tab:
 - a Select which port to use.
 - b Click **Setup** for the selected port to define the communication parameters.
 - c Select which **NMEA Sentence** to use.

If you choose *Auto*, the ES70 will automatically choose among the incoming information according to a predefined priority list.

d If applicable, define the **Talker ID**.

4 Click **OK** to save the current settings and close the dialog.

How to set up the motion sensor interface

The ES70 Fish finding echo sounder can accept inputs from both analogue and digital heave sensors. A sensor with an analogue output is connected directly to the **Auxiliary** connector on the General Purpose Transceiver, while a digital sensor is connected to one of the serial inputs using RS-232.

If more than one transceiver is used by the echo sounder system, the analogue sensor is connected to only one of them.

Supported telegram formats

- *Sounder/TSS1 Motion protocol* on page 173
- *Simrad EM Attitude 1000* on page 168
- *Simrad EM Attitude 3000* on page 169

Wiring procedure

- 1 Locate a free RS-232 serial port that can be used to connect the sensor.
- 2 On the ES70 computer, connect the receive signal **Rx** on pin 2, and **ground** on pin 5.
→ *Generic RS-232 Serial line* on page 42
- 3 On the motion sensor, wire as described in the relevant documentation.

Setup procedure

This procedure explains how the ES70 can be set up to receive motion sensor information on a serial port.

- 1 Click the **Setup** icon under the **Main** menu to open the **Setup** sub-menu.



- 2 Click **Installation** to open the **Installation** sub-menu.



On the sub-menu **I/O Setup** to open the **I/O Setup** dialog.



- 3 In the **I/O Setup** dialog, select which serial line to use to accept motion sensor information.
- 4 Click on the chosen port to select it, then click the **Input** button to open the **Select Inputs** dialog.

- 5 In the **Select Inputs** dialog, locate the **AML** on the left side, and click the [**>**] button to connect it.

This setting allows you to communicate with the motion sensor system.

The following proprietary telegram formats are supported:

- *Sounder/TSSI Motion protocol* on page 173
- *Simrad EM Attitude 1000* on page 168
- *Simrad EM Attitude 3000* on page 169

- 6 Click **OK** to save the current settings and close the dialog.
- 7 In the **I/O Setup** dialog, click on the chosen port to select it, then click the **Setup** button to open the **Serial Setup** dialog.
- 8 In the **Serial Setup** dialog, enter the relevant parameters to set up the port.
- 9 Click **OK** to save the current settings and close the dialog.
- 10 In the **I/O Setup** dialog, click on the chosen port to select it, then click the **Monitor** button to open the **Port Monitor** dialog.
In order to monitor the data flow, the motion sensor system must be active and transmitting information to the ES70.
- 11 If the data flow is operational, close all dialogs.

How to set up the depth output

The ES70 Fish finding echo sounder will output depth information on several different formats.

Supported telegram formats

- *DBS Depth below surface* on page 161
- *DBT Depth below transducer* on page 162
- *DPT Depth* on page 162
- *Simrad EK500 Depth* on page 167
- *Atlas depth telegram* on page 175
- *PSIMDHB Bottom hardness and biomass* on page 172

Wiring procedure for serial communication

- 1 Locate which RS-232 port you wish to use.
- 2 The ES70 Fish finding echo sounder, connect the transmit signal **Tx** on pin 3, and **ground** on pin 5.
→ *Generic RS-232 Serial line* on page 42
- 3 On the remote system, wire as described in the relevant documentation.
- 4 Ensure that the length of the cable does not exceed approximately 50 meters. If a longer cable is required, you may need to use buffer amplifiers on the serial line.

Setup procedure

- 1 Click the **Setup** icon under the **Main** menu to open the **Setup** sub-menu.



- 2 Click **Depth Output** to open the **Depth Output** dialog.



- 3 Select which port to use.
- 4 For the selected port, click **Setup** to define the communication parameters.
- 5 Select which telegram to send.
- 6 If applicable, define the Talker ID.
- 7 Select which transceiver and frequency you wish to export the depth information from.
In most cases, the lowest frequency is used.
- 8 Click **OK** to save the current settings and close the dialog.

How to set up the annotation interface

The ES70 Fish finding echo sounder can accept annotation (text) input from an external system.

Supported telegram formats

- *Simrad ATS Annotation* on page 174

Wiring procedure for serial communication

Note

The ASCII datagram with the external annotation must be connected to the same serial line as the navigation system.

- 1 Locate a free RS-232 serial port that can be used to connect the external system.
- 2 On the ES70 computer, connect the receive signal **Rx** on pin 2, and **ground** on pin 5.
→ *Generic RS-232 Serial line* on page 42
- 3 On the external system, wire as described in the relevant documentation.
- 4 Ensure that the length of the cable does not exceed approximately 50 meters. If a longer cable is required, you may need to use buffer amplifiers on the serial line.

Setup procedure

- 1 Click the **Setup** icon under the **Main** menu to open the **Setup** sub-menu.



- 2 Click **Annotations** to open the **Annotations** dialog.



- 3 Click **Port** so select communication port.
- 4 Click **Setup** so define the communication parameters.
- 5 Click **OK** to save the current settings and close the dialog.

ES70 External triggering

Whenever more than one hydroacoustic system (echo sounder or sonar) is installed on a vessel, interference may occur. To avoid this, the systems may either be connected to a common synchronization system, or one of the acoustic systems may be defined as a *Master*.

The ES70 echo sounder include interface for remote transmit synchronisation. The system can be set up to operate in either *Master* or *Slave* mode in relation to an external synchronization or hydroacoustic system.

The ES70 system may comprise more than one General Purpose Transceiver. If the ES70 operates as a *Master*, the synchronization between these are controlled by the echo sounder software. If the echo sounder operates as a *Slave* system, the transceivers must be individually controlled by the *Master* system.

Note

In its default configuration, the ES70 is set up to operate as a Master. Special action must be taken to reconfigure the echo sounder for Slave operation. This is made in the Operation dialog by selecting External triggering.

Synchronisation using a serial line

According to the standard specifications for RS-232, an output must generate a voltage level of +5 to +15 Vdc (logic “low”), and -5 to -15 Vdc (logic “high”) into a load of 3 to 7 k Ω . An RS-232 receiver must present a 3 to 7 k Ω load, converting an input of +3 to +25 Vdc to logic “low”, and an input of -3 to -25 Vdc to logic “high”.

The physical wiring between the ES70 computer and the sonar Interface Unit is shown in section *Sonar synchronisation* on page 44. Any of the ES70 serial lines can be used, and it connects to terminal board **TB8** in the Interface Unit.

Related topics

- *Sonar synchronisation* on page 44
- *RS-232 as external trigger* on page 43

Master system

On the ES70 computer, **RTS** (pin 7) goes logical “low” (typically +10 Vdc) approximately 2 to 3 ms prior to transmitting, and returns to logical “high” (typically -10 Vdc) when the echo sounder have finished sampling the echo data.

Slave system

The ES70 triggers on a positive edge from the sonar (level exceeds +3 Vdc) on **CTS** (pin 8).

Note

On Simrad ES70 software versions prior to 2.2.0. pin 7 on the echo sounder must not be connected when the echo sounder runs in “slave” mode.

Older Simrad sonars

On older Simrad sonars, you must use a serial line on each end. The ES70 serial line must then be connected to a serial line on the sonar according to the description in section *RS-232 as external trigger* on page 43.

Synchronisation using GPT Auxiliary plug

The General Purpose Transceiver (GPT) is equipped with an auxiliary socket, and this interface device supports trigger pulses.

Related topics

- *GPT trigger / synchronisation* on page 58

Master system

When the ES70 system is set up to operate as a *Master* in a system, the **TrigOut** signal from the transceiver’s **Auxiliary** connector must be connected to the external trigger input on the other hydroacoustic system(s). If more than one transceiver is used by the *Master* system, the **TrigOut** signal must be taken from the active transceiver. Two **TrigOut** signals are available for either positive or negative triggering. When activate, the trigger signal will allow all the systems to transmit simultaneously.

Note

Simultaneous transmission of more than one system can only take place if the systems operate with different frequencies!

The **TrigOut+** signal is an open collector output (max 100 mA) containing a 100 kohm pullup resistor to +5 Vdc. This signal is normally low. The **TrigOut+** signal goes high when the transceiver is ready to transmit, and it goes low again when all frequency channels of the transceiver have finished transmitting.

TrigOut- is the inverse of **TrigOut+**.

Connect the ground wire to one of the **Ground** pins (18-22).

Slave system

If an external system is used to provide the transmit trigger, the trigger signal must be connected to one of the **TrigIn** inputs on the transceiver's **Auxiliary** connector. When activated, the trigger signal from the external system will allow the ES70 system to transmit.

If more than one transceiver is used by the *Slave* system, the input trigger must be connected to all the transceivers in parallel.

Two **TrigIn** inputs are available for either positive or negative triggering. The **TrigIn-** input is sensitive to a high-to-low transition.

Connect the ground wire to one of the **Ground** pins (18-22).

GPT Auxiliary plug schematics

The circuitry providing input and output triggering – as well as other interfaces – are provided in the schematics below.

Figure 17 Digital input

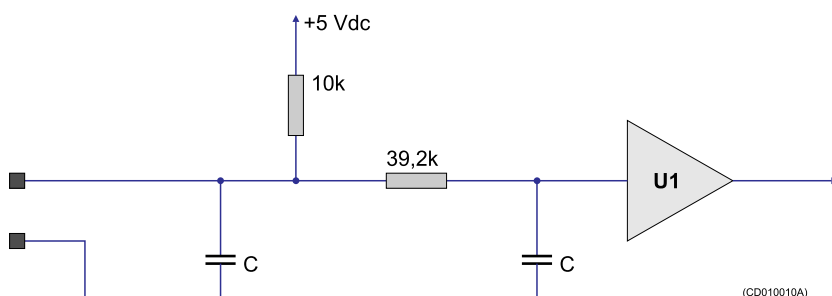

This digital input circuitry is valid for the following interfaces: **TrigIn+**, **TrigIn-**, **Event** and **Log**.

Figure 18 Digital output

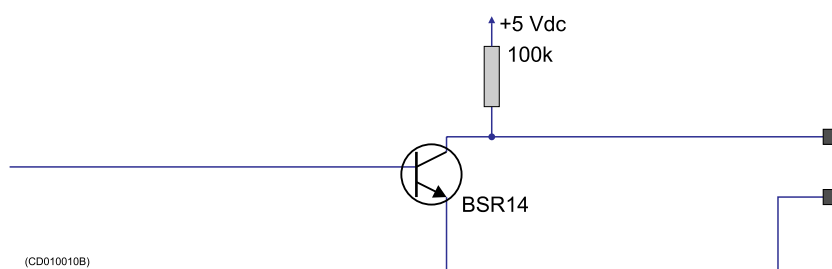

This digital output circuitry is valid for the following interfaces: **TrigOut+**, **TrigOut-** and **Alarm**.

Note

The current that can be drawn from this open collector circuitry is limited to 100 mA

Figure 19 Differential input

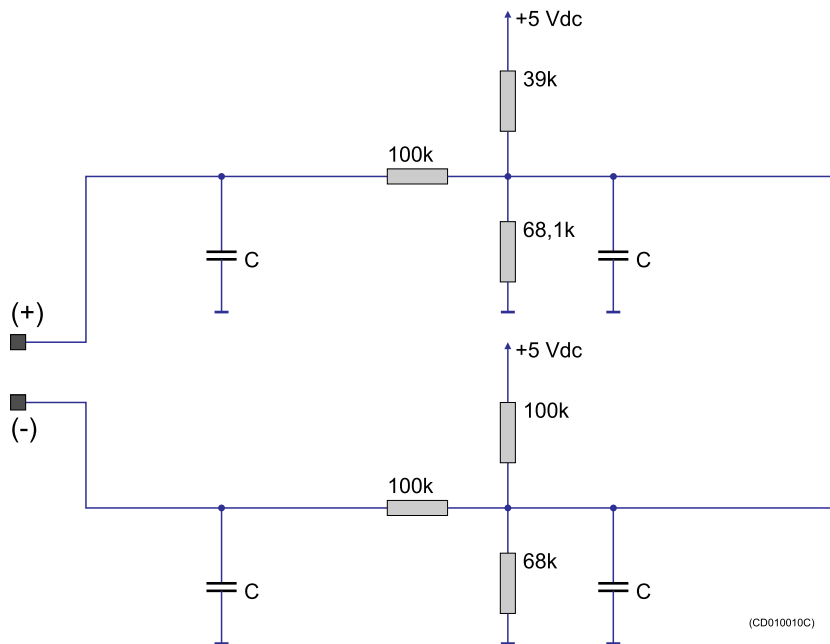

This differential input circuitry is valid for the following interfaces: **Heave, Pitch and Roll.**

Note

Maximum differential input range is ± 10 Vdc.

GPT Auxiliary connector

The ES70 General Purpose Transceiver (GPT) board contains a 25-pin female Delta connector handling various external interface signals.

Figure 20 GPT Auxiliary connector

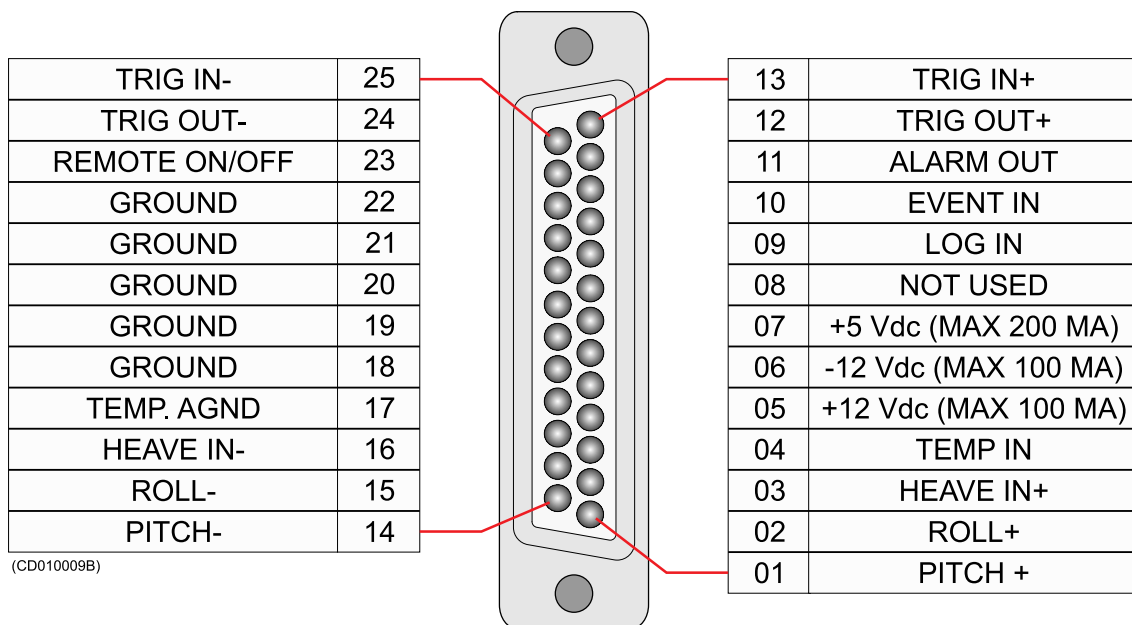

Interfaces on the Auxiliary plug

- Analogue heave sensor (pins 3 and 16)

One differential input is connected to the sensor output terminal, the other input is grounded at the sensor in order to prevent ground potential offsets between the sensor and the transceiver from being adding to the sensed signal. The differential input range is ± 10 V.

Note

This input is not supported by the ES70 Fish finding echo sounder.

- Temperature sensor (pins 4 and 17)

Some transducers contain a built-in temperature sensitive resistor, normally 10 kohm at 25°C. This resistor is used to measure the water temperature.

Note

This input is not supported by the ES70 Fish finding echo sounder.

- Supply voltages (output)
 - Pin 5: +12 Vdc, max 100 mA (Ground on pin 18)
 - Pin 6: -12 Vdc, max 100 mA (Ground on pin 19)
 - Pin 7: +5 Vdc, max 200 mA (Ground on pin 20)
- Transmit synchronisation (pins 12, 13, 23, 24 and 25)
 - **TrigIn** and **TrigOut** are digital signals provided for transmit synchronisation with external equipment of various makes.
 - **TrigOut+** is normally low, and **TrigOut-** is the logical inverse of **TrigOut+**.
 - In internal trigger mode, **TrigOut+** goes high (output transistor is not conducting) when the transmit pulse starts, and it goes low again when all frequency channels within the transceiver have finished transmitting. The **TrigIn** signals are totally disregarded.
 - In external trigger mode, transmission is delayed until a pulse is detected at one of the **TrigIn** inputs; a low-to-high transition at the **TrigIn+** input or a high-to-low transition at the **TrigIn-** input. **TrigOut+** goes high when the transceiver is ready to transmit, and it goes low again when all frequency channels within the transceiver have finished transmitting.
 - The **RemoteIn** signal at pin 23 switches the transceiver on/off. Left open the transceiver is on. If grounded (less than +2.5 Vdc) the transceiver is off.

- Event in

Use a simple non-locking push-to-make switch to trigger an event. A vertical line is drawn on the echogram

Note _____

This input is not supported by the ES70 Fish finding echo sounder.

- Alarm out

A positive (+ 5Vdc) level is provided when the alarm is enable.

Note _____

Note that this output must not be used to power lamps, speakers or sounder directly. The alarm signal must be connected to an opto-coupler, a relay or a similar device to power peripheral alarm units.

Note _____

This output is not supported by the ES70 Fish finding echo sounder.

Related topics

- *GPT remote on/off* on page 56
- *GPT trigger / synchronisation* on page 58

Drawing file

This chapter contains relevant drawings related to the electrical and physical installation of the ES70 Fish finding echo sounder.

Note

The mechanical drawings are for information and guidance only. They are not in scale. All dimensions are in mm unless otherwise is noted.

The original installation drawings are available on PDF and/or AutoCad's DWG format. Visit www.simrad.com to download.

List of drawings

- *GPT Outline dimensions* on page 102
- *GPT Power supply outline dimensions* on page 104
- *Marine computer outline dimensions* on page 106
- *GPT Transducer plug connection* on page 107

GPT Outline dimensions

Page 1

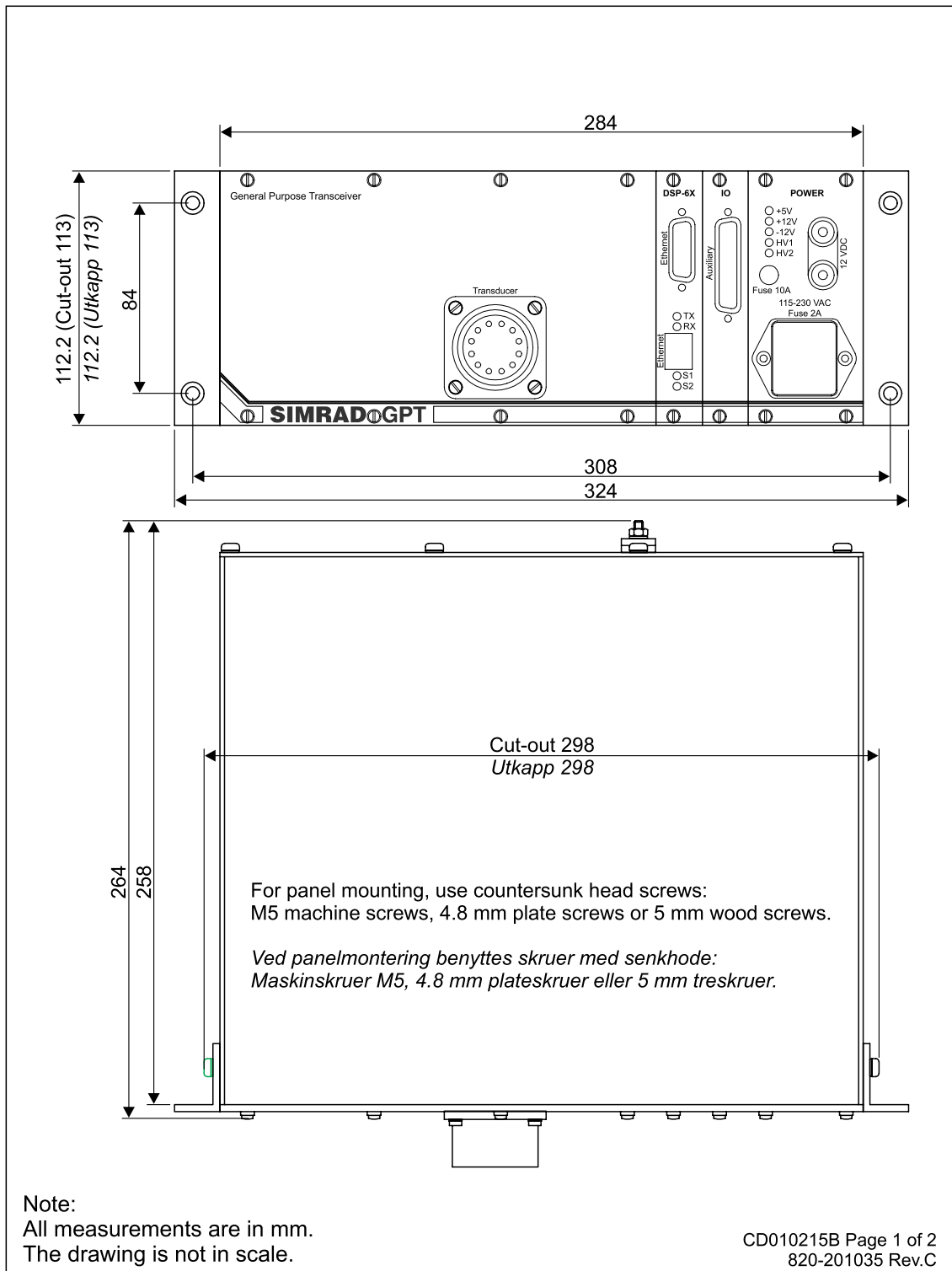

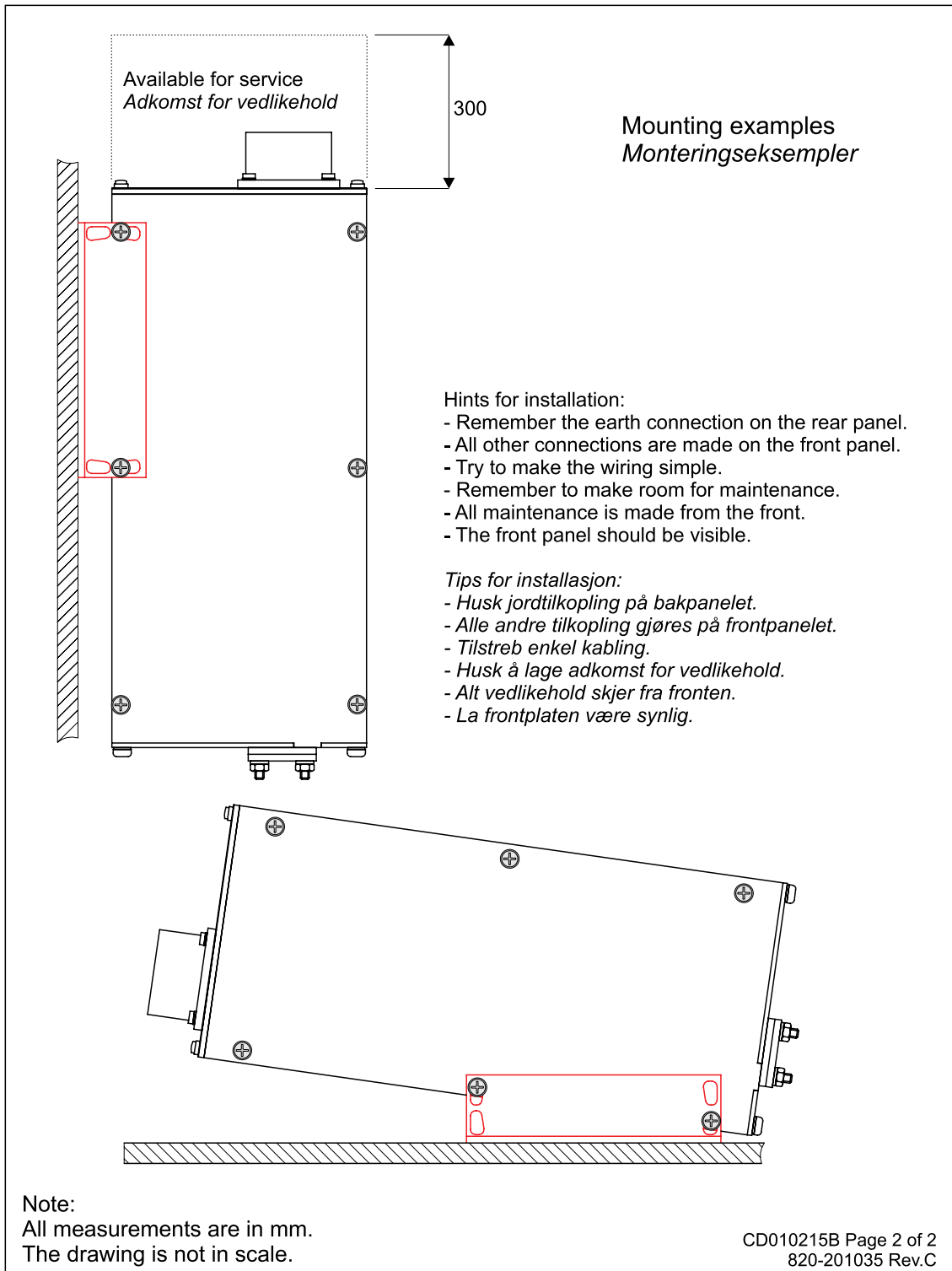

GPT Power supply outline dimensions

Page 1

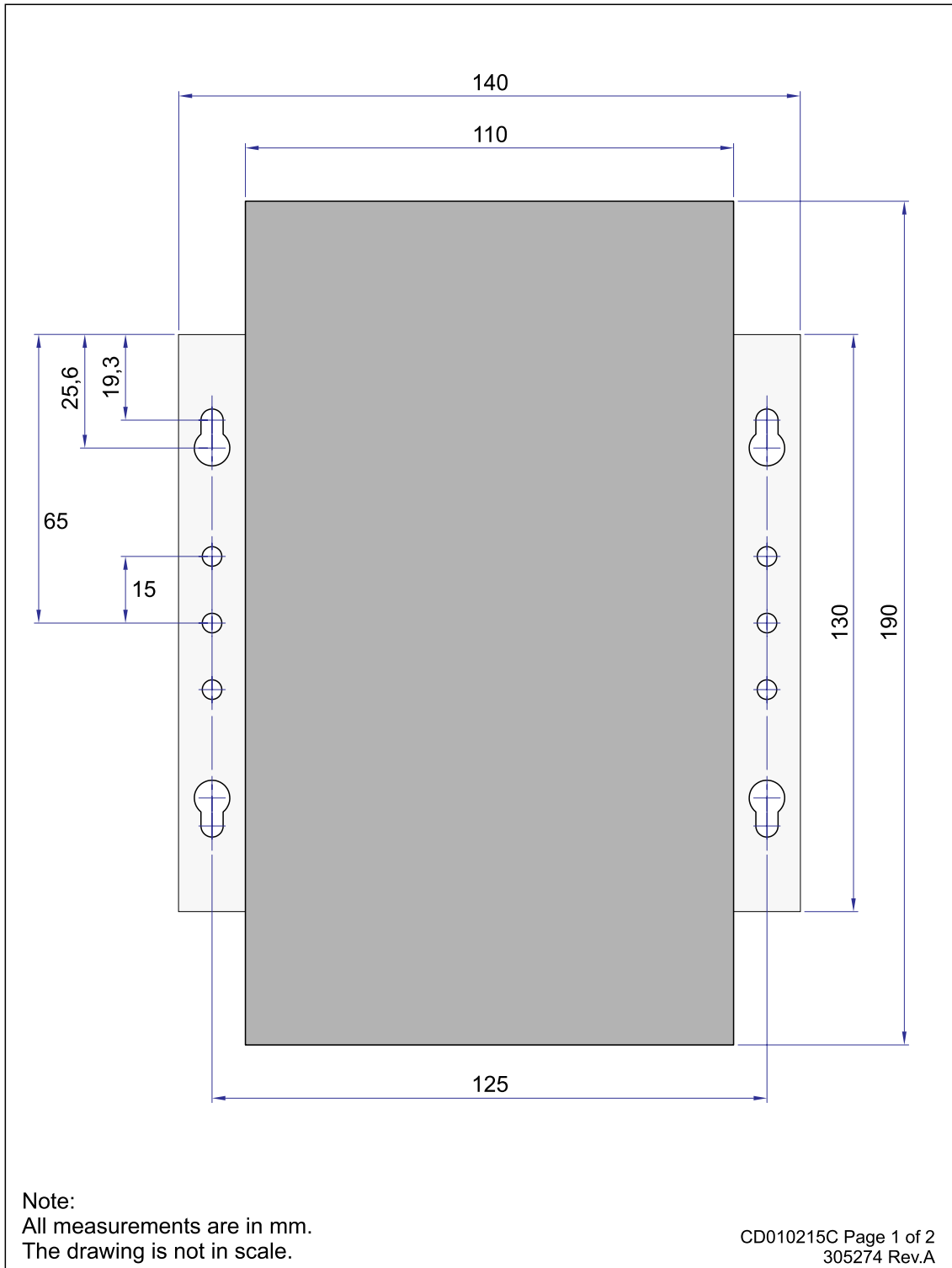

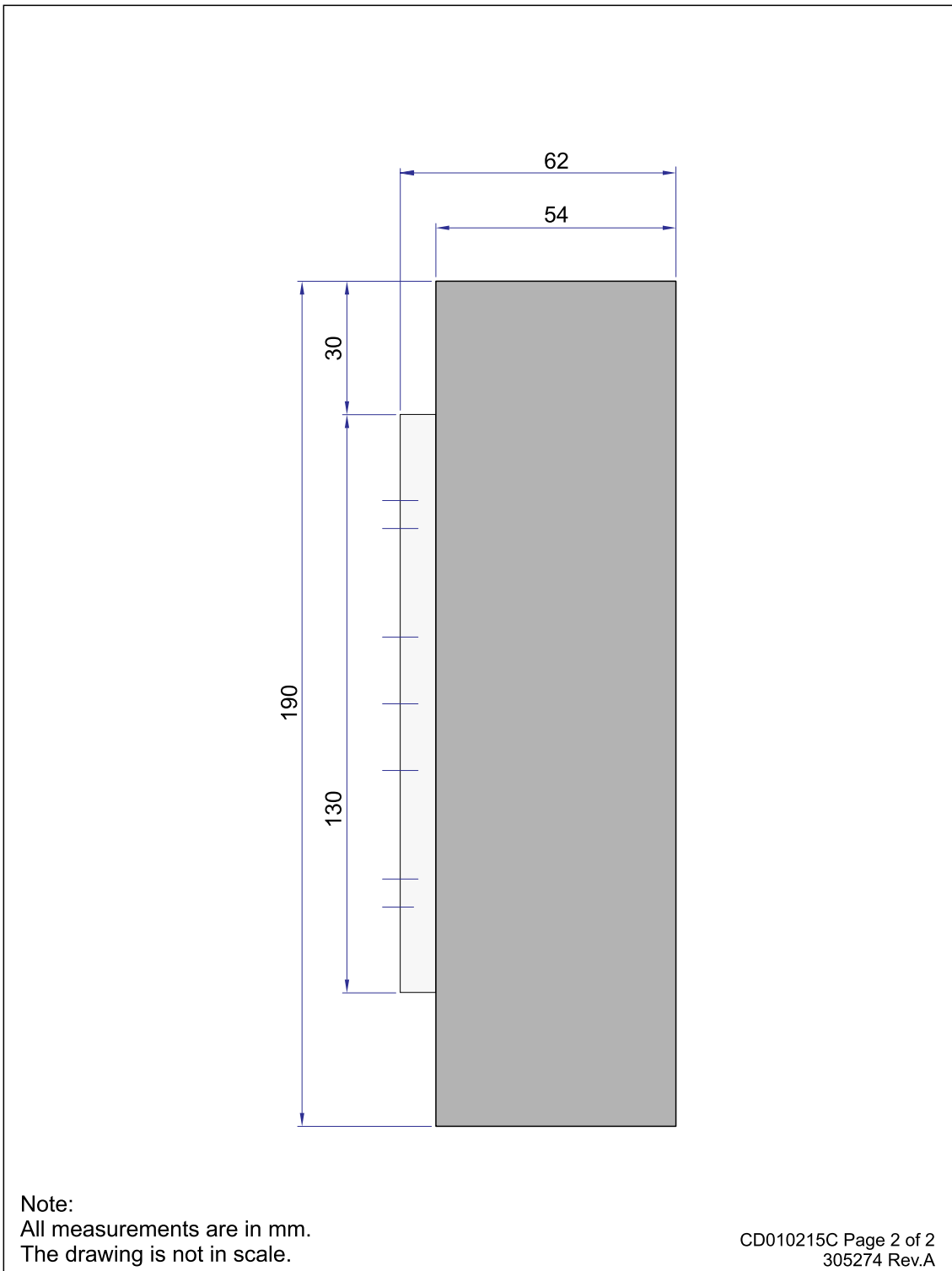

Marine computer outline dimensions

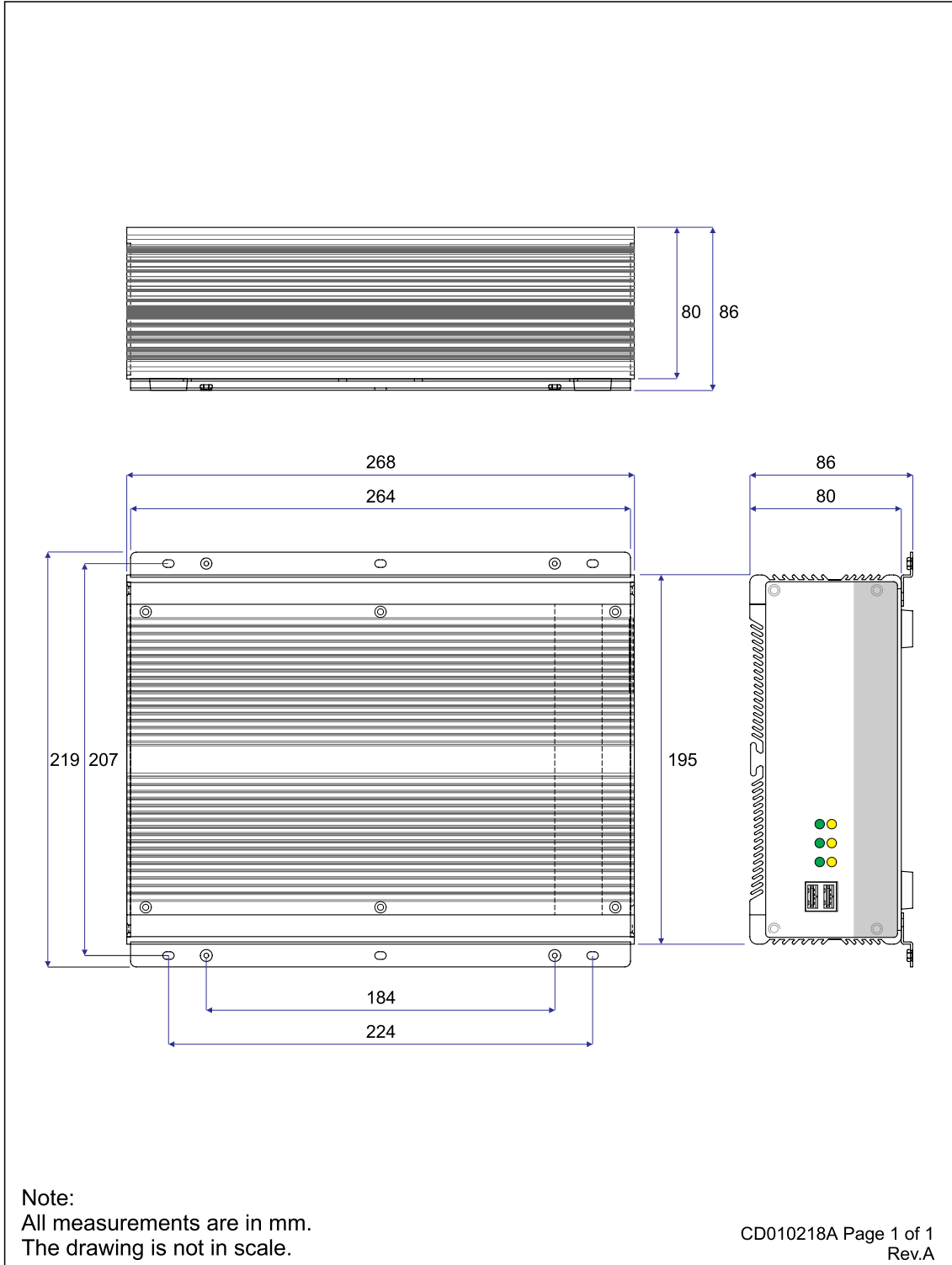

GPT Transducer plug connection

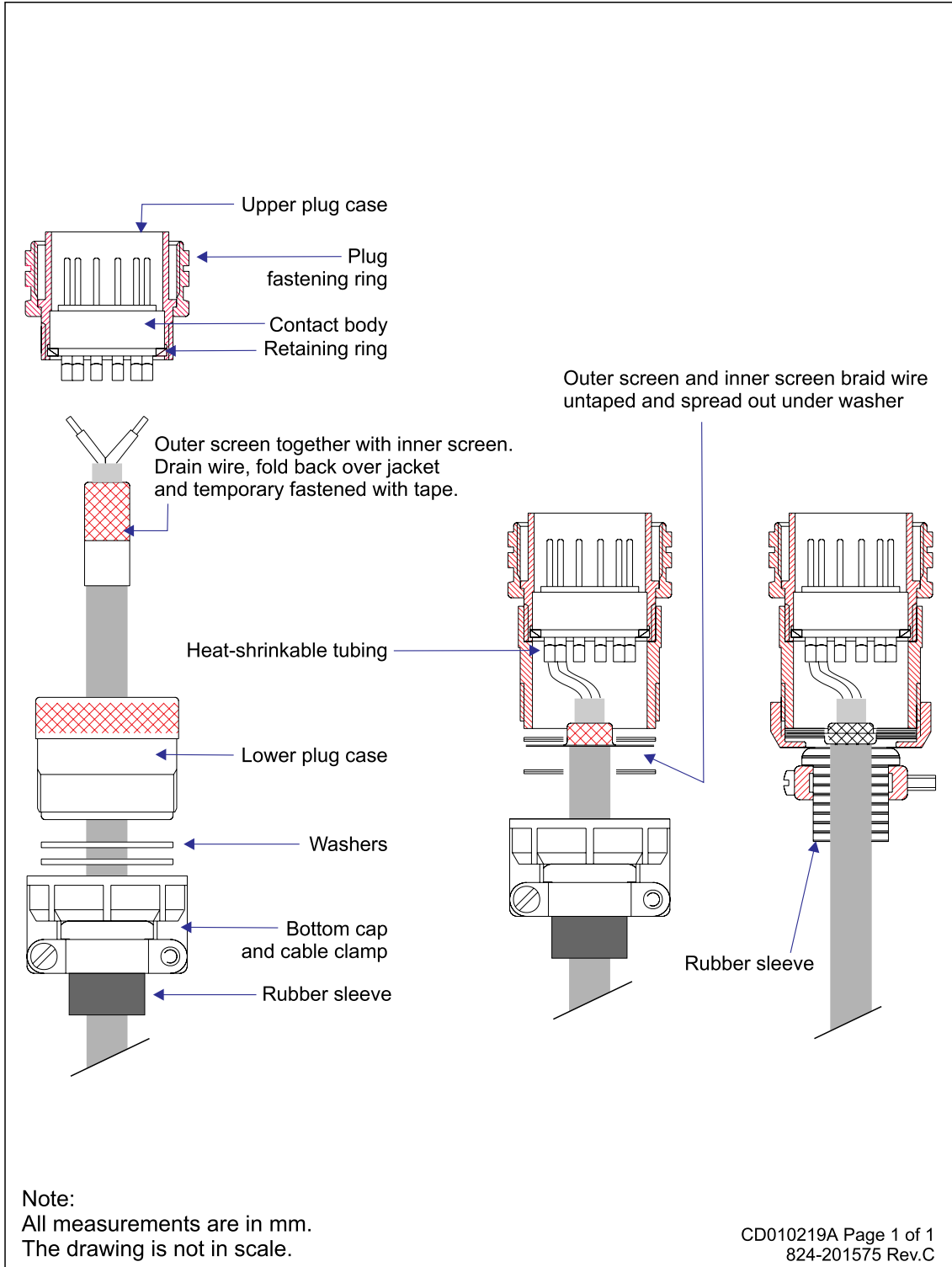

Technical specifications

This chapter lists the main technical specifications.

Note

We reserve the right to alter technical specifications without prior notice.

Related topics

- *Echo sounder specifications* on page 108
- *General Purpose Transceiver (GPT) specifications* on page 109
- *Colour display specifications* on page 111
- *ES70 Marine Computer specifications* on page 111

Echo sounder specifications

- **Frequency channels:** Maximum 7 channels
- **Operating frequencies:** 12, 18, 27, 38, 50, 70, 120, 200 kHz
- **Echogram types:**
 - Surface echogram
 - Pelagic echogram
 - Bottom expansion
 - Trawl echogram
- **Gain functions:**
 - 20 log TVG (= bottom gain)
 - 20 log TVG (=school gain)
 - 40 log TVG (= fish gain)
 - User TVG
- **Ping rate:** Adjustable, depends on transducer limitations
- **Start depth and range:** 5 to 15,000 meters in Manual, Auto range or Auto start modes.
- **Scope presentation:** Displays the echo strength of the most recent ping.
- **Colour scale:** 12 colours (3 dB pr colour) or 64 colours

- **Bottom detector:** Software tracking algorithm, adjustable minimum and maximum depth

Interface specifications

Numerous external interfaces are provided for the ES70 Fish finding echo sounder system.

- **Outputs:**
 - Echogram printer (Centronics parallel or USB depending on computer make and model)
 - Bottom depth (Serial line, NMEA format)
 - Depth data (Serial line, NMEA, Simrad or Atlas formats)
- **Inputs:**
 - Navigation receiver (Serial line, NMEA format)
 - Motion sensor (Heave, roll and pitch) (Serial line)
 - Annotation
 - Transmit synchronization
- **Remote control toggle switch:**
 - Remote power
 - Transmit synchronization

General Purpose Transceiver (GPT) specifications

Operational specifications

- **Transmit power:**
 - Maximum 1 + 1 kW (Dual frequency GPT)
 - Maximum 4 kW (Single frequency GPT)
- **Receiver noise figure:** 3 dB
- **Transducer impedance:** 60 ohms
- **Output protection:** Short circuit and open circuit protection
- **Receiver input range:** Instantaneous dynamic amplitude range -150 dBW to -20 dBW (dB relative to 1W)

Physical and environmental specifications

- **Connectors:**
 - Transducer: 12-pin female Amphenol, Shell MS3102A-24, Insert 24-19S
 - AUI: 15-pin female Delta (see below)
 - Network: 8-pin RJ-45 socket
 - Auxiliary: 25-pin female Delta
- **AUI Connector:**
 - Analog input for heave, roll and pitch
 - Digital trigger in/out
 - Alarm output
 - +12 Vdc output (maximum 100 mA)
 - -12 Vdc output (maximum 100 mA)
 - +5 Vdc output (maximum 200 mA)
- **Physical dimensions:**
 - Width: 284 mm
 - Height: 112 mm
 - Depth: 246 mm
 - See also: *GPT Outline dimensions* on page 102
- **Weight:**
 - With one transmitter board: 2.7 kg
 - With two transmitter boards: 3.3 kg
 - With three transmitter boards: 4.5 kg
- **Standard supply power:**
 - AC operation: 95 to 265 Vac, 50-60 Hz, 50-100 W
 - DC operation: 11 to 15 Vdc, 50-100 W
- **External power supply for specific configurations:**
 - AC input: 230 Vac, 50–60 Hz
 - DC output: 13.2 Vdc, 10 A
 - Physical size (excluding mounting brackets) (WDH): 110 x 190 x 54 mm
 - See also: *GPT Power supply outline dimensions* on page 104
- **Fuses:**
 - AC fuse: Ø5x20 mm, 2 A slow
 - DC fuse: Ø5x20 mm, 10 A slow or fast
- **Operational temperature:** 0 to +55°C
- **Storage temperature:** -40 to +70°C
- **Humidity:** 5 to 95% relative non-condensing

Colour display specifications

Commercial display

The ES70 Fish finding echo sounder may be supplied with one of several LCD displays, and several sizes are available. Specifications are supplied with the displays. Refer to the applicable documentation provided with the unit for more information.

ES70 Marine Computer specifications

Operational specifications

- **Processor and memory:**
 - **Processor:** Core Duo (T2500)
 - **Clock frequency:** 2 GHz
 - **Chipset:** Intel® 852 GM(E)
 - **RAM:** 4 Gb
 - **Hard disk:** 30 Gb Solid State Drive
 - **Moving parts:** None
- **Interfaces:**
 - **USB 2.0:** 6 sockets
 - **Keyboard/mouse:** Dual PS/2 connector (adapter is included)
 - **Serial lines:** 4 ea RS-232/RS-422/RS-485 (adapter is included)
 - **Network:** 2 x 10/100/1000 Mhz Ethernet LAN
 - **Video:** VGA and DVI
- **Power requirements:**
 - **External power supply:** 100 to 240 Vac input, +19 Vdc output
 - **DC operation:** +12 to 30 Vdc
- **Certification:**
 - CE
 - FCC

Physical and environmental specifications

- **Mechanical construction:**
 - **Chassis:** Aluminium
 - **Cooling:** Integrated cooling ribs
 - **Mounting:** Brackets on each side

- **Physical dimensions:**
 - Depth: 195 mm
 - Width: 268 mm
 - Height: 80 mm
- **Environmental specifications:**
 - Operating temperatures: -10 to +50°C
 - Storage temperatures: -20 to +80°C
 - Relative humidity: 10 to 90% (non-condensing)

Local purchase

If you purchase a computer locally, it is important to make sure that the chosen model meets the functional system requirements. It is important that the computer can facilitate the various interface requirements made by the system, and you may need to add extra Ethernet and serial adapters. Also, make sure that the computer design and construction allows for marine use and safe installation. A laptop computer may be used as long as it meets the functional requirements.

Minimum computer requirements

- **Operating system:** Microsoft® Windows® XP® or Microsoft® Windows® 7 [7]
On new installations, we recommend that Microsoft® Windows® 7 is used.
- **Processor speed:** 2 GHz Dual core
- **Memory:** 2.0 Gb
- **Free hard disk space:** 30 Gb
- **Chipset:** Intel
- **Graphic adapter:** DirectX9.0c compatible with Direct3d and OpenGL^[8]
- **Interfaces:**
 - One Ethernet interface to communicate with the transceiver
 - One Ethernet interface to communicate with ship's local area network (if required)
 - One or more serial line interfaces (depends on how many interfaces that are required for the specific integration)
- **Display resolution:** 1280 x 1024^[9]

7. The ES70 software does not support Microsoft© Windows© NT or older operating systems.
8. A large number of commercial graphic adapters are available, and Simrad has not tested all of them. Even adapters meeting the minimum specifications may in some cases prove to fail with the ES70 software. We welcome any feedback with comments or experiences with graphic adapters.
9. This is the minimum resolution. As with all other Windows applications, the ES70 software will work with higher resolutions, provided that it is supported by the graphic adapter in the computer and the display connected.

Transducer Installation

The purpose of this chapter is to provide generic descriptions and illustrations allowing the reader to understand the basic principles for echo sounder transducer installation.

Note

The information in this document must be regarded as general guidelines and recommendations only. The installation shipyard must design and manufacture installation hardware to fit each individual transducer and vessel.

Whenever required, the installation shipyard must also have the installation approved by the applicable maritime authorities.

For detailed information about the transducer to be installed, refer to the documentation provided with the transducer. Drawings and descriptions can also be downloaded from www.simrad.com.

Topics

- *Where to mount the transducer* on page 113
- *How to install the transducer* on page 117
- *Transducer cable glands and splicing* on page 137
- *Steel conduit* on page 142
- *Transducer handling and maintenance* on page 143

Where to mount the transducer

A single answer to the question where to locate the transducer cannot be given. It depends very much on the vessel's construction, how the hull is shaped and how the water runs along the hull. There are however a number of important guide lines, and some of these are even conflicting.

Mount the transducer deep

Mount the transducer at a deep position on the hull. Consider the situations when the vessel is unloaded, and when it is pitching in heavy seas.

There are several reasons for this.

- 1 The upper water layers of the sea contain a myriad of small air bubbles created by the breaking waves. In heavy seas the upper 5 to 10 metres may be filled with air, and the highest concentrations will be near the surface. Air bubbles absorb and reflect the sound energy, and they may in worst cases block the sound transmission altogether.
- 2 Another reason to go deep is the cavitation in front of high power transducers. Cavitation is the formation of small bubbles in the water due to the resulting local pressure becoming negative during parts of the acoustic pressure cycles. The cavitation threshold increases with the hydrostatic pressure.
- 3 The transducer must never be lifted free of the water surface. Transmitting into open air may damage the transducer beyond repair. Mounting the transducer at a deep position on the hull prevents this.
- 4 If the transducer is lifted up from the water during heavy seas, it may be damaged when the hull strikes back at the sea surface. This is especially important for low frequency transducers with large faces.

Mount the transducer midway between the bow and the stern to avoid heave effects

Heave is the up and down movement of the vessel. It disturbs the echo traces in the echogram, so that a flat bottom is displayed as a wave. A transducer location in the middle of the vessel minimises the influence of vessel roll and pitch.

Mount the transducer away from protruding objects on the hull

Objects protruding from the hull, such as zinc anodes, sonar transducers or even the vessel's keel, generate turbulence and flow noise. Holes and pipe outlets are also important noise sources. They may act as resonant cavities amplifying the flow noise at certain frequencies. Do not place an echo sounder transducer in the vicinity of such objects, and especially not close behind them. For the same reason, it is very important that the hull area around the transducer face is as smooth and level as possible. Even traces of sealing compound, sharp edges, protruding bolts or bolt holes without filling compound will create noise.

Mount the transducer at the forward part of the hull to minimise the effects from the boundary water layer

When the vessel forces its way through the sea, the friction between the hull and the water creates a boundary layer. The thickness of the boundary layer depends upon vessel speed and the roughness of the hull. Objects protruding from the hull, and dents in the hull, disturb the flow and increase the thickness of the boundary layer. The flow in this boundary layer may be laminar or turbulent. A laminar flow is a nicely ordered, parallel movement of the water. A turbulent flow has a disorderly pattern, full of eddies. The boundary layer increases in thickness when the flow goes from laminar to turbulent. The figure below illustrates the boundary layer of a vessel moving through the water.

Figure 21 Boundary water layer

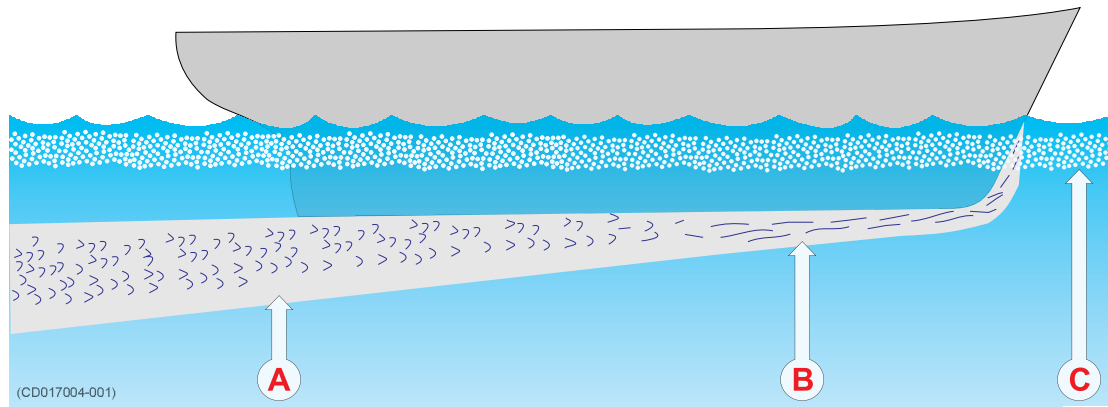

- A *Turbulent flow*
- B *Laminar flow*
- C *Air bubbles in the water*

Furthermore, air bubbles in the sea water are pressed down below the hull and mixed into the boundary layer. The boundary layer is thin underneath the forward part of the vessel, and increases in thickness as it moves towards aft. If the sides of the hull are steep, some of the air bubbles in the boundary layer may escape to the sea surface along the vessel sides. It is our experience that a wide and flat bottom, with a rising angle less than around 13 degrees, is prone to giving air problems for the transducer. In any case a transducer location in the forward part of the hull is preferred in order to minimise the influence of the boundary layer.

Mount the transducer far away from the propellers

The propulsion propeller is the dominant noise source on most fishing vessels, research vessels, merchant vessels and pleasure crafts. The noise is transmitted through the sea water. For this reason, the transducer should be placed far away from the propeller, which means on the fore part of the hull. Positions outside the direct line of sight from the propeller are favourable. On small vessels with short distances it is advised to mount the transducer on that side of the keel where the propeller blades move upwards, because the propeller cavitation is strongest on the other side. The cavitation starts most easily when the water flows in the same direction as the propeller blade, and that is to some degree the case at that side of the keel where the propeller blades move downwards.

Mount the transducer far away from the bow thrusters

Bow thruster propellers are extremely noisy. When in operation, the noise and cavitation bubbles created by the thruster make the echo sounder useless, almost no matter where the transducer is installed. And when not in operation, the tunnel creates turbulence, and if the vessel is pitching, the tunnel may be filled with air or aerated water in the upper position and release this in the lower position. In general, all transducers must be therefore placed well away from the bow thruster. However, this is not an invariable

rule. Certain thruster designs combined with its physical location on the hull may still offer suitable transducer locations near the thruster. If you are in doubt, consult a naval architect.

Mount the transducer with a slightly inclined transducer face

Ideally, the transducer face should be mounted in parallel with the sea surface when the vessel is in normal trim, as this will provide the most accurate echo information. However, it is also very important that the water flow over the transducer face is laminar. In order to ensure laminar flow, the transducer face may be tilted slightly upwards in relation to the water flow. This allows the flowing water to meet the face directly, and assures laminar flow. The inclination angle must however be determined carefully. The angle must be small on transducers with narrow beam angles. As a rule of thumb, mount transducers with beam angles smaller than seven degrees with minimum inclination angle. The smaller beam angle your transducer has, the smaller the inclination angle can be. Ensure that you do not mount the transducer with a negative inclination angle. This may cause turbulence under the transducer face, and reduced echo sounder performance.

Summary and general recommendations

Some of the above guide lines are conflicting, and each case has to be treated individually in order to find the best compromise. Generally the propeller noise is the dominant factor, and a recommended transducer location is in the fore part of the hull, with maximum distance from the bow equal to one third of the total length of the hull at the water line.

Figure 22 General recommendation for transducer location

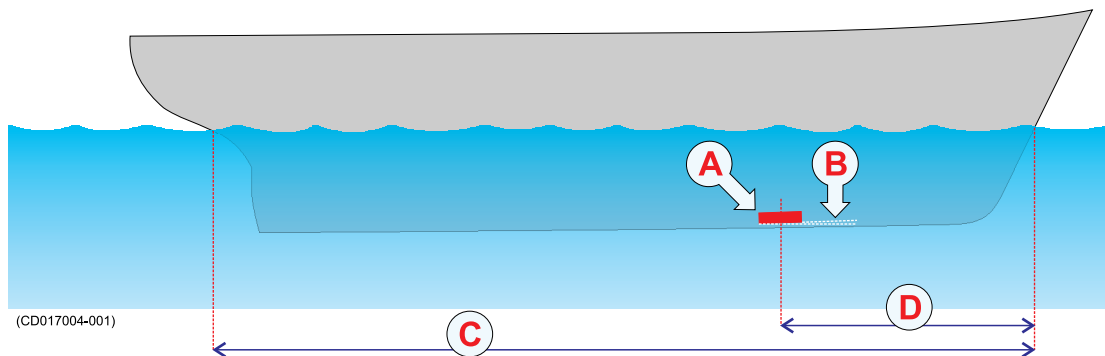

- A** *Transducer*
- B** *Inclination angle*
- C** *Hull length at water line*
- D** *Maximum 1/3 of the hull length at water line (C)*

If the vessel hull has a bulbous bow, this may well be a good transducer location, but also here must be taken into consideration the flow pattern of the aerated water. Often the foremost part of the bulb is preferable.

Figure 23 Recommended location of the transducer on a bulbous hull

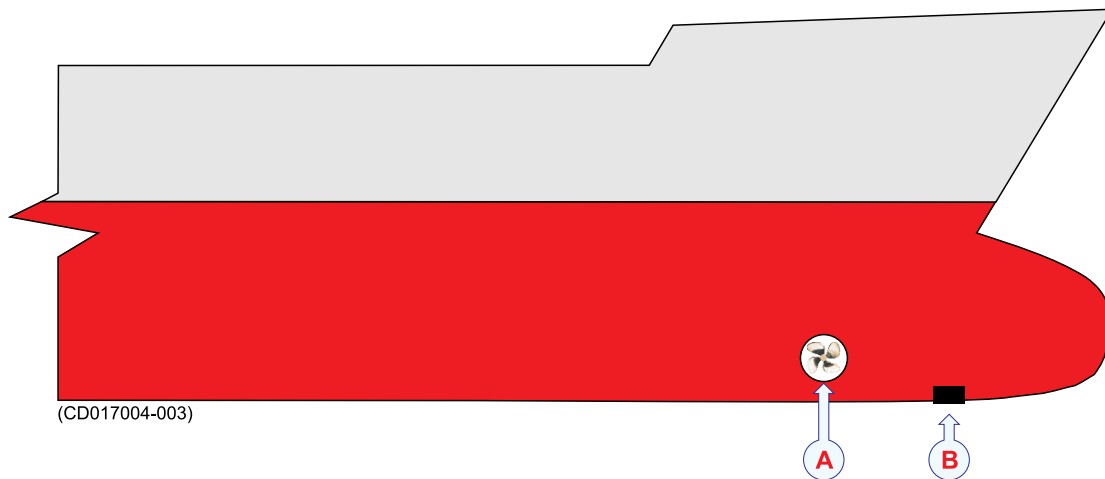

A Thruster

B Transducer location

How to install the transducer

There are many different ways to mount the transducer. These are the recommended methods to mount a streamlined and circular transducers under the hull or in a towed body.

Topics

- *External mounting of streamlined transducer* on page 118
- *Transducer installation in blister* on page 121
- *Transducer installation in box keel* on page 127
- *Transducer flush mounted in a steel tank* on page 128
- *Transducer with acoustic window* on page 130
- *Transducer mounted inside the hull* on page 131
- *Transducer mounted on a drop keel* on page 133
- *Retractable transducer* on page 134
- *Towed body installation* on page 134

External mounting of streamlined transducer

Certain transducers have a streamlined housing, and these are designed for installation outside the hull. These transducers are mainly used on smaller vessels. A location approximately 0.5 m aside from the keel may be adequate for the passage of water between the keel and the transducer. The figures illustrate external mounting of transducers on steel hulls and on wood or polyester hulls respectively.

Smooth surface is important

Mounting screws or bolts must not be extruding from the transducer or the area immediately around it. Make sure that the surface of the transducer face, the installation hardware used to mount it, the hull plating and the putty around the transducer is as even and smooth as possible. Obstructions on these surfaces will create problems with turbulent flow.

Toe-in

The primary consideration must be to allow laminar water flow. In most cases this is achieved by designing the blister in parallel with the keel. However, if the blister is located close to the bow, the front of the blister may have a few degrees toe-in towards the bow.

Figure 24 Toe-in principle

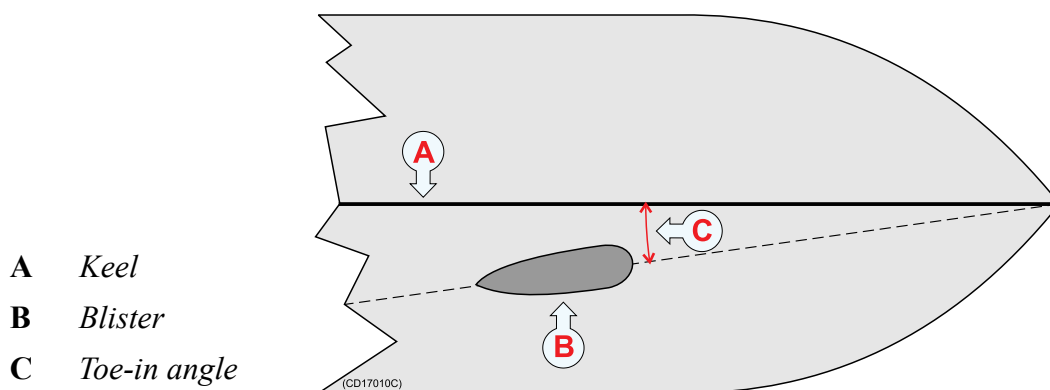

The angle must be chosen to allow for most efficient water flow. It will vary with the location of the transducer; the depth below the hull, the distance from the bow, and the distance to the keel. Typical angles are from 0 to 3° on displacement hulls. On planing hulls, the angle is normally close to 0°.

Example: Streamlined transducer on steel hull

A fairing (A), made by the shipyard, is placed between the transducer and the hull. It is required in order to adapt for the deadrise angle of the hull, and it will also house a cable service loop (B). The fairing can be made of wood or steel, and should have the same outline dimensions as the transducer. Remember to create an air outlet (E) on the fairing, and to fill the bolt holes with a filling compound to ensure a smooth transducer surface.

Figure 25 Streamlined transducer on steel hull

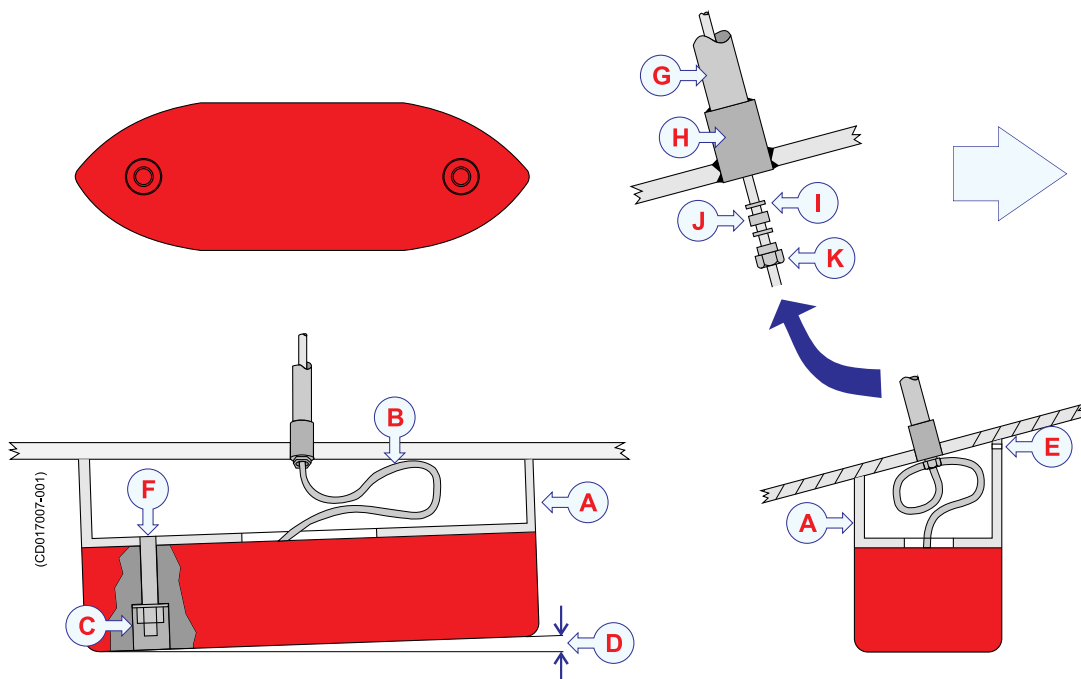

- | | | | |
|----------|--|----------|-----------------------|
| A | <i>Fairing</i> | G | <i>Steel conduit</i> |
| B | <i>Cable service loop</i> | H | <i>Stuffing tube</i> |
| C | <i>Filling compound</i> | I | <i>Washer</i> |
| D | <i>Inclination angle</i> | J | <i>Rubber gasket</i> |
| E | <i>Air outlet</i> | K | <i>Packing nipple</i> |
| F | <i>Threaded rod with nuts and washers, or bolt</i> | | |

Example: Streamlined transducer on wooden or polyester hull

A fairing (A), made by the shipyard, is placed between the transducer and the hull. It is required in order to adapt for the deadrise angle of the hull, and will also house a cable service loop (B). The fairing is made from wood, polyester or steel, and should have the same outline dimensions as the transducer. Use tarred felt (H) between the fairing and the hull. Remember to create an air outlet (E) on the fairing, and to fill the bolt holes with a filling compound to ensure a smooth transducer surface.

Figure 26 Streamlined transducer on wooden or polyester hull

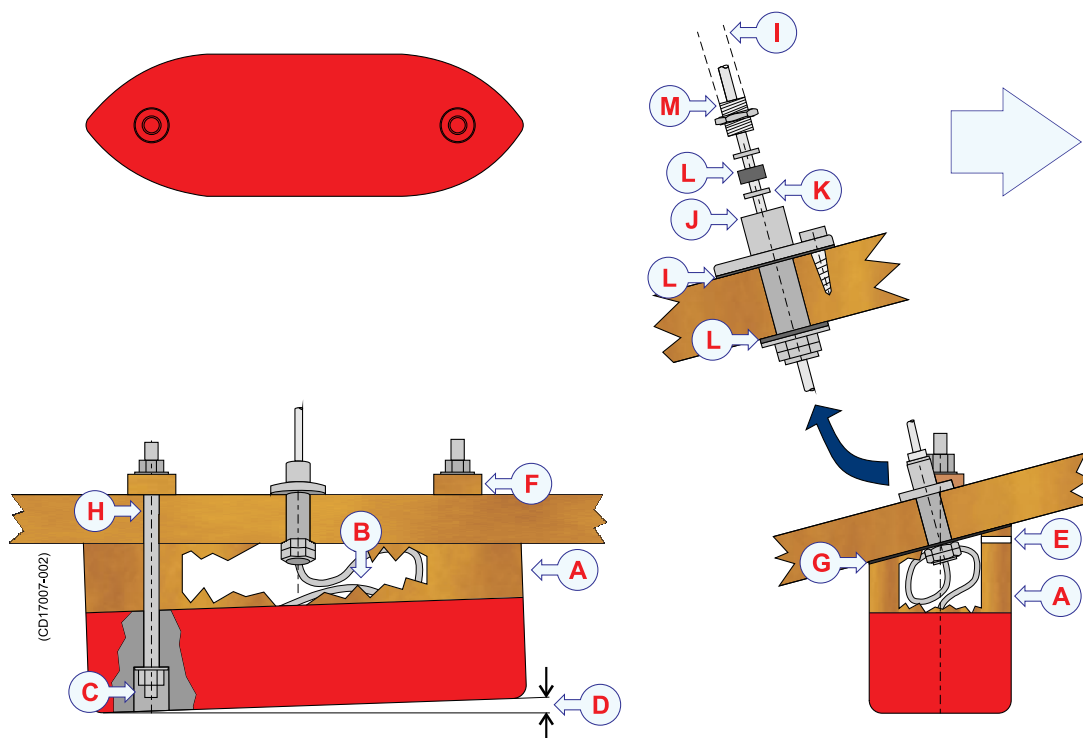

- | | |
|-----------------------------|--|
| A Fairing | H Threaded rod with nuts and washers, or bolt |
| B Cable service loop | I Steel conduit |
| C Filling compound | J Stuffing tube |
| D Inclination angle | K Washer |
| E Air outlet | L Rubber gasket |
| F Shim (wood) | M Packing nipple |
| G Tarred felt | |

Example: Streamlined transducer on hull with flat bottom

If the vessel’s hull is flat you do not need a fairing. The transducer is then be bolted directly to the hull using two bronze or stainless steel bolts (I) and a cable bushing. Note that the cable bushing must be mounted with proper gaskets (4) under and over the hull, as well as sealing compound (J) around its body. Also, fill the bolt holes with a filling compound to ensure a smooth transducer surface.

Figure 27 Streamlined transducer on hull with flat bottom

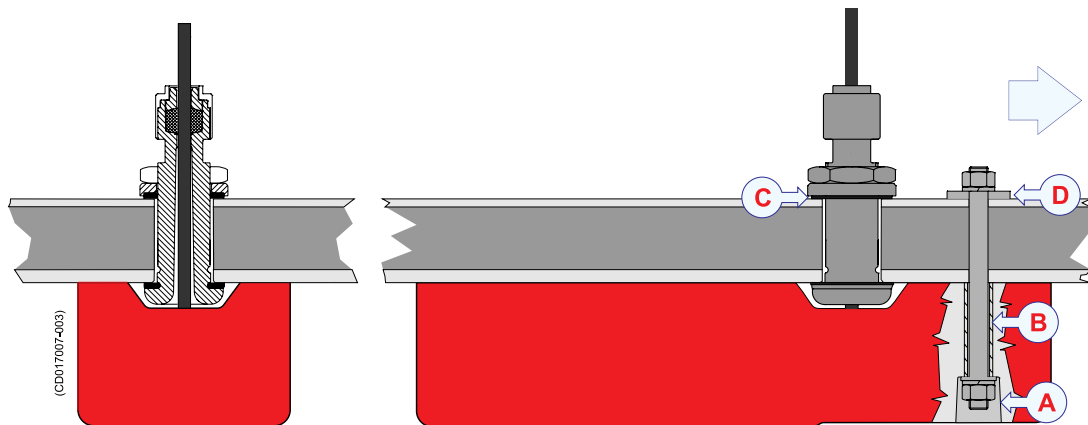

- A Filling compound
- B Threaded rod with nuts and washers, or bolt
- C Rubber gasket
- D Washer

Transducer installation in blister

With a transducer with circular housing, one recommended installation method is by using a blister. The transducer blister must be designed and manufactured by the installation shipyard to fit the vessel’s size and hull shape.

Use mounting and clamping rings whenever provided

Circular transducers may be provided with mounting and clamping rings, or with drawings to allow for local production of these. The mounting ring is welded to the hole prepared for the transducer, while the clamping ring fits around the edge of the transducer body. Bolts through the clamping ring into the mounting ring will secure the transducer between them. Note that several transducers use direction guides to allow correct mounting.

Smooth surface is important

Mounting screws or bolts must not be extruding from the transducer or the area immediately around it. Make sure that the surface of the transducer face, the installation hardware used to mount it, the hull plating and the putty around the transducer is as even and smooth as possible. Obstructions on these surfaces will create problems with turbulent flow.

Use a horizontal support bar on large transducers

We strongly recommend that large transducers are fitted with a horizontal support bar.

The purpose of this support bar is to protect the transducer from damage in the event of slamming. This happens if the vessel hull climbs out of the water in heavy seas. The force of the water when the hull falls down may push the transducer up and cause damage to its mounting. The support bar can be secured to the mounting ring using threaded rods.

Slamming is the impact of the bottom structure of a ship onto the sea surface. It is mainly observed while sailing in waves, when the bow raises from the water and subsequently impacts on it. Slamming induces extremely high loads to ship structures and is taken under consideration when designing ships.

— *Wikipedia*

Example: Large circular transducer

The illustration below shows a typical transducer blister designed for a large transducer. Note that due to the physical size of the transducer, a U-shaped support bar (E) is used to support the transducer. The purpose of this support is to prevent the transducer from being pushed up into the blister in heavy seas.

Figure 28 Large circular transducer

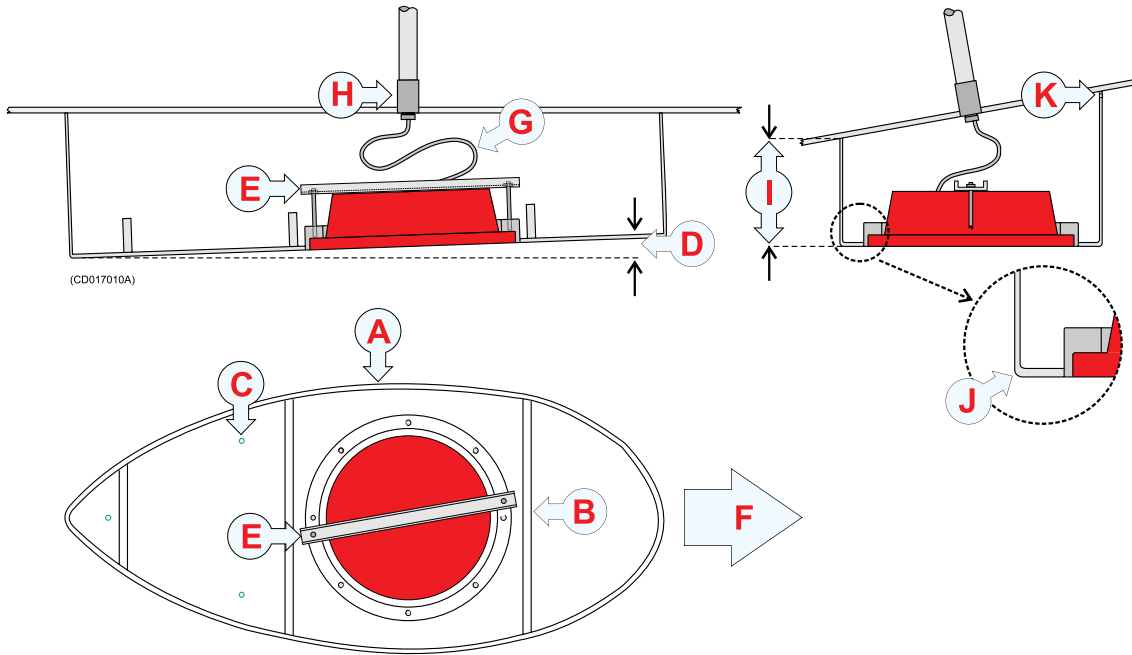

- | | | | |
|----------|--|----------|---------------------------|
| A | <i>Streamlined blister</i> | F | <i>Forward</i> |
| B | <i>Stiffening rib</i> | G | <i>Cable service loop</i> |
| C | <i>Drainage holes</i> | H | <i>Stuffing tube</i> |
| D | <i>Inclination angle</i> | I | <i>Minimum 400 mm</i> |
| E | <i>U-shaped support bar (recommended on large transducers)</i> | J | <i>Rounded corners</i> |
| | | K | <i>Air outlet</i> |

Example: Small circular transducer

The illustration below shows a typical transducer blister designed for a small transducer. The same blister design principles as for a large transducer apply.

Figure 29 Small circular transducer

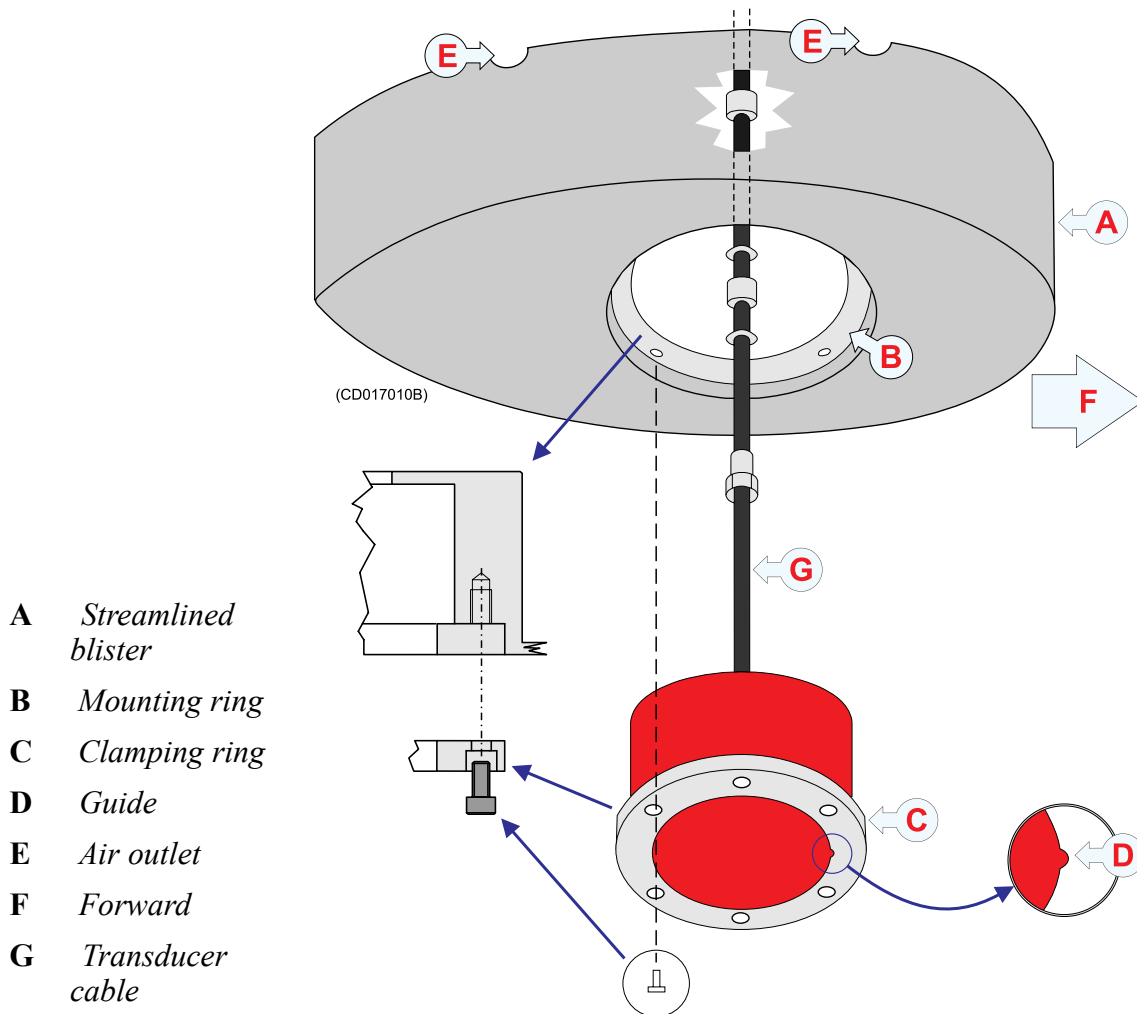

Note that the transducer cable must be provided with a cable loop inside the blister. Observe the vertical forward edge of the blister. This will guide the water to each side of the blister.

Example: Medium sized circular transducer without clamping ring

The illustration below shows a transducer blister designed for a medium sized transducers. The same blister design principles apply. Note that the transducer is mounted without a clamping ring, which makes it necessary to use a different mounting ring design.

Figure 30 Medium sized circular transducer without clamping ring

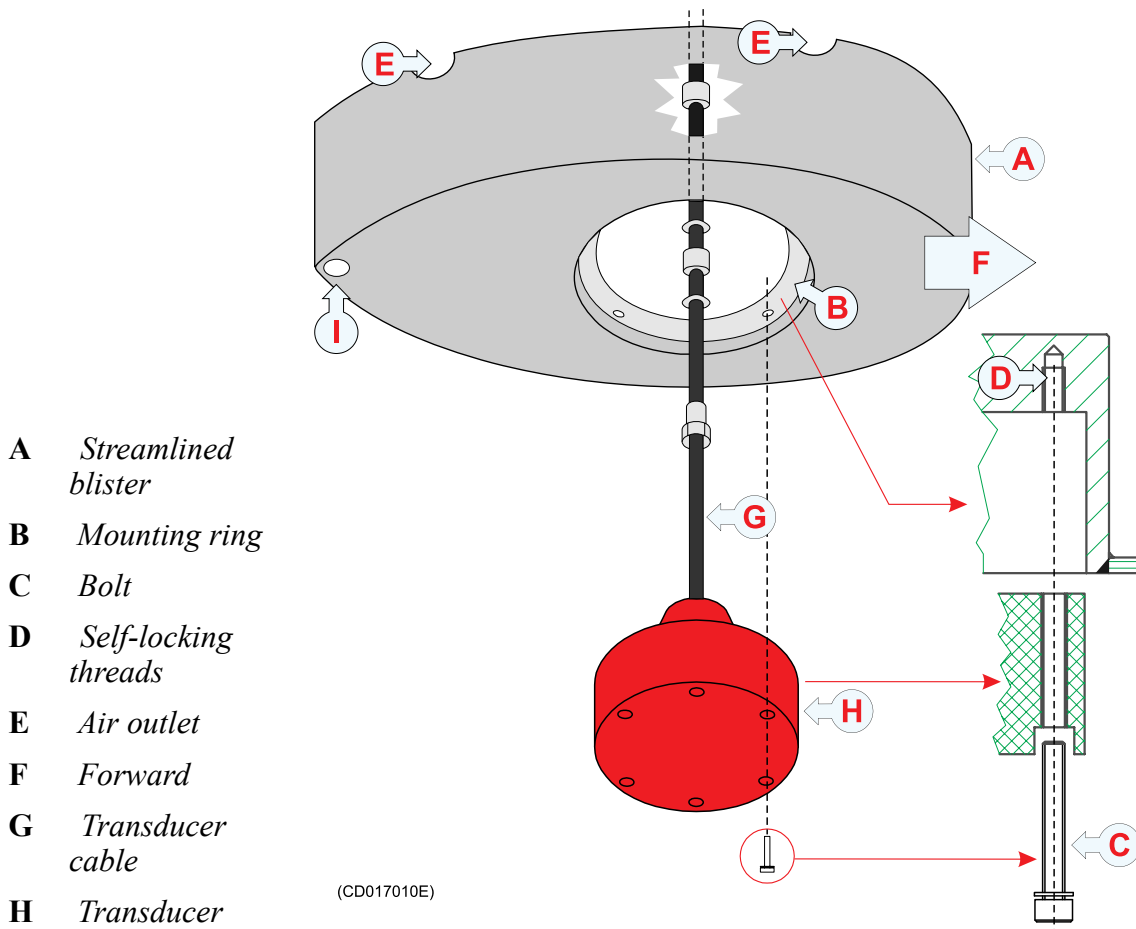

Note that the transducer cable must be provided with a cable loop inside the blister. Observe the vertical forward edge of the blister. This will guide the water to each side of the blister.

Common guidelines

The best performance is obtained with a blister height of 40 cm or more. A streamlined shape and rounded edges reduce the flow noise. A vertical leading edge or front will guide the aerated water to the sides of the blister. The orientation of the blister should follow the water flow.

The interior of the blister must be filled with sea water. Use drainage holes in the bottom and an air outlet on the top. The water pressure behind the transducer will then compensate for the outside pressure during vessel movements in rough sea.

We recommend that large diameter transducers are fitted with a horizontal U-shaped support bar. This bar can then be secured to the mounting ring using threaded rods.

The transducer cable penetrates the hull in a stuffing tube. Leave an adequate loop of the cable behind the transducer for easy mounting or removal of the transducer.

Toe-in

The primary consideration must be to allow laminar water flow. In most cases this is achieved by designing the blister in parallel with the keel. However, if the blister is located close to the bow, the front of the blister may have a few degrees toe-in towards the bow.

Figure 31 Toe-in principle

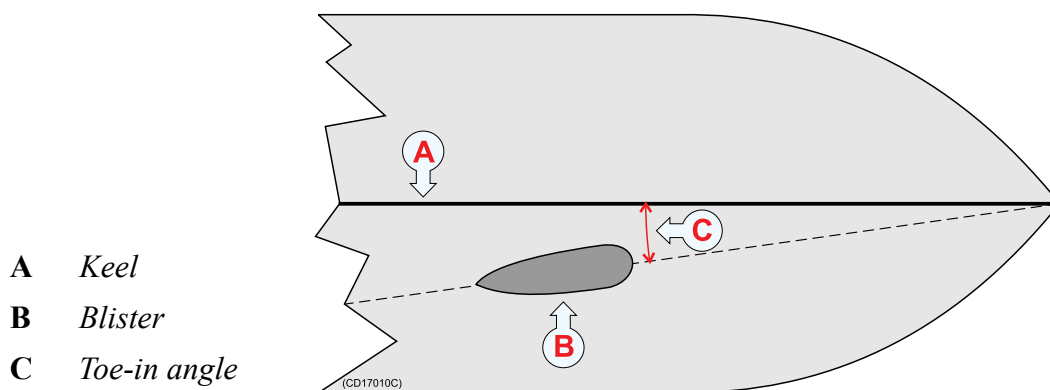

The angle must be chosen to allow for most efficient water flow. It will vary with the location of the transducer; the depth below the hull, the distance from the bow, and the distance to the keel. Typical angles are from 0 to 3° on displacement hulls. On planing hulls, the angle is normally close to 0°.

Physical location

The blister is placed on one of the sides of the hull, and the distance from the keel is a trade off between a close distance giving a turbulent flow of water in a narrow passage, and a large distance bringing the transducer higher up and also more affected by vessel roll. Normally a distance of approximately 1 m is a good compromise.

Observe the horizontal and vertical distances (C and D) between the keel and the transducer blister. On a medium sized vessel, the horizontal distance (C) should be approximately 1 meter. The vertical distance (D) must in general be as small as possible. This is important to prevent the keel from shadowing the transducer beam in shallow waters.

- A Keel
- B Transducer blister
- C Horizontal distance between keel and blister
- D Vertical distance between the blister surface and the keel

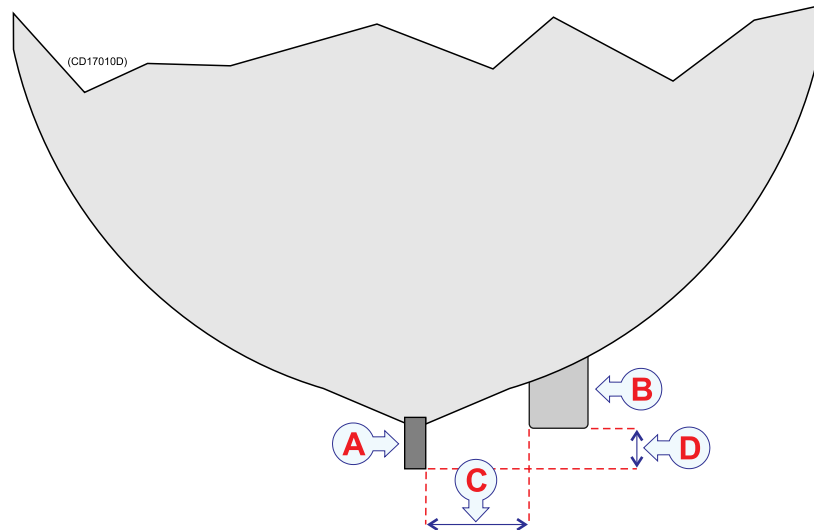

Transducer installation in box keel

Vessels with a box keel may use this for transducer installation.

The box keel is already the deepest part of the vessel. If the box keel is too narrow to accommodate the transducer, it can be widened, either symmetrically or to one side only. In the last case the installation could also be described as a blister merged into the keel.

Use mounting and clamping rings whenever provided

Circular transducers may be provided with mounting and clamping rings, or with drawings to allow for local production of these. The mounting ring is welded to the hole prepared for the transducer, while the clamping ring fits around the edge of the transducer body. Bolts through the clamping ring into the mounting ring will secure the transducer between them. Note that several transducers use direction guides to allow correct mounting.

Smooth surface is important

Mounting screws or bolts must not be extruding from the transducer or the area immediately around it. Make sure that the surface of the transducer face, the installation hardware used to mount it, the hull plating and the putty around the transducer is as even and smooth as possible. Obstructions on these surfaces will create problems with turbulent flow.

Use a horizontal support bar on large transducers

We strongly recommend that large transducers are fitted with a horizontal support bar.

The purpose of this support bar is to protect the transducer from damage in the event of slamming. This happens if the vessel hull climbs out of the water in heavy seas. The force of the water when the hull falls down may push the transducer up and cause damage to its mounting. The support bar can be secured to the mounting ring using threaded rods.

Slamming is the impact of the bottom structure of a ship onto the sea surface. It is mainly observed while sailing in waves, when the bow raises from the water and subsequently impacts on it. Slamming induces extremely high loads to ship structures and is taken under consideration when designing ships.

— Wikipedia

Example: Box keel installation

The figure below illustrates a symmetrical box keel installation.

Figure 32 Box keel installation

- A Box keel
- B U-shaped support bar (only recommended on large transducers)
- C Stuffing tube
- D Cable in steel conduit
- E Cable service loop

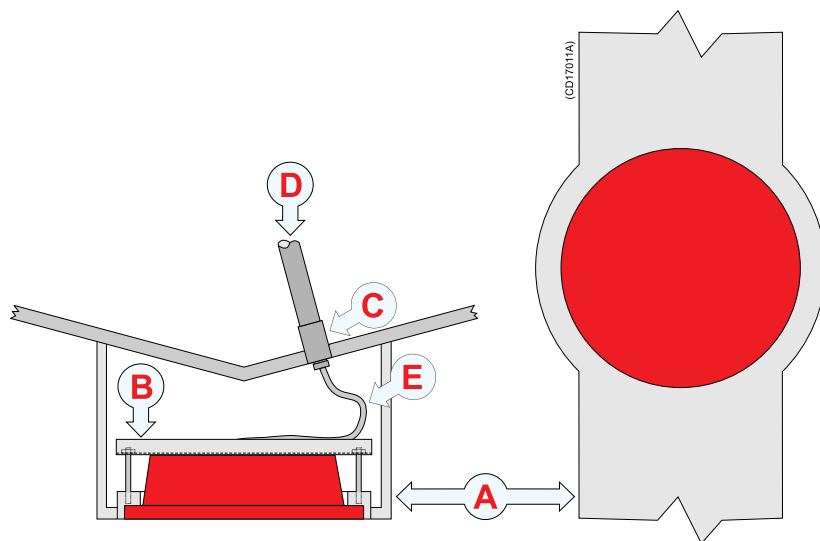

Transducer flush mounted in a steel tank

Flush mounting is used on very large vessels with a hull so deep that no air bubbles are found below the hull, and on vessels operating in shallow harbours or waters, where a protruding blister can not be accepted.

The standard procedure for flush mounting on a steel vessel is to weld a steel tank inside the hull, and mount the transducer into this tank.

Use mounting and clamping rings whenever provided

Circular transducers may be provided with mounting and clamping rings, or with drawings to allow for local production of these. The mounting ring is welded to the hole prepared for the transducer, while the clamping ring fits around the edge of the transducer body. Bolts through the clamping ring into the mounting ring will secure the transducer between them. Note that several transducers use direction guides to allow correct mounting.

Smooth surface is important

Mounting screws or bolts must not be extruding from the transducer or the area immediately around it. Make sure that the surface of the transducer face, the installation hardware used to mount it, the hull plating and the putty around the transducer is as even and smooth as possible. Obstructions on these surfaces will create problems with turbulent flow.

Use a horizontal support bar on large transducers

We strongly recommend that large transducers are fitted with a horizontal support bar.

The purpose of this support bar is to protect the transducer from damage in the event of slamming. This happens if the vessel hull climbs out of the water in heavy seas. The force of the water when the hull falls down may push the transducer up and cause damage to its mounting. The support bar can be secured to the mounting ring using threaded rods.

Slamming is the impact of the bottom structure of a ship onto the sea surface. It is mainly observed while sailing in waves, when the bow raises from the water and subsequently impacts on it. Slamming induces extremely high loads to ship structures and is taken under consideration when designing ships.

— *Wikipedia*

Water filled

As for a blister, the interior of the tank must be filled with water.

This can be accomplished by air release through a steel tube, which is extended either to open air 1.5 m above the water line or to the water outside the hull at a point higher than the tank interior.

If the tube is extended to open air, drainage must be provided with leakage at the transducer flange or a separate hole in the tank bottom.

Example: Flush mounting in a steel tank

Transducer mounting in a steel tank is shown in the figure below.

Figure 33 Flush mounting in a steel tank

- A Steel tank
- B Water
- C Drainage hole
- D Cable service loop
- E Steel tube for air outlet
- F Stuffing tube
- G Cable in steel conduit

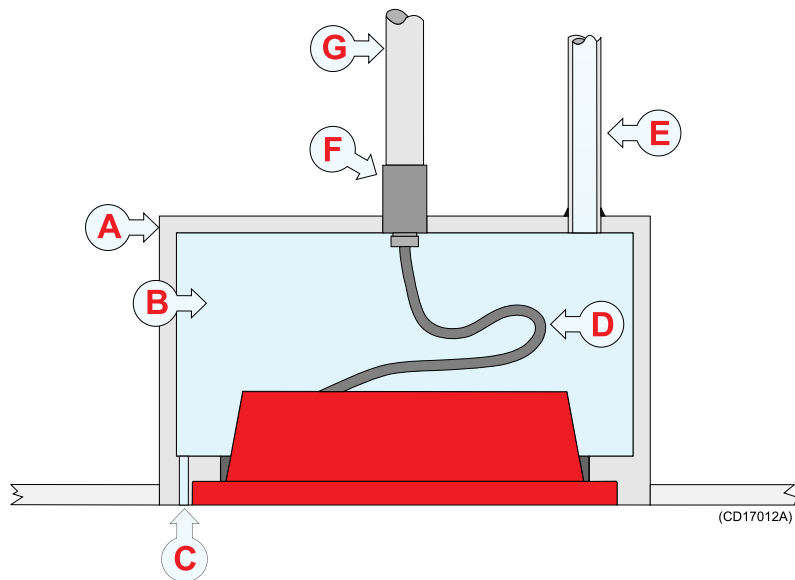

Transducer with acoustic window

Vessels operating in arctic waters need special attention on transducer installation. Floating blocks of ice may damage even a flush mounted transducer face. For this situation Simrad offers arctic tanks in different sizes.

Use mounting and clamping rings whenever provided

Circular transducers may be provided with mounting and clamping rings, or with drawings to allow for local production of these. The mounting ring is welded to the hole prepared for the transducer, while the clamping ring fits around the edge of the transducer body. Bolts through the clamping ring into the mounting ring will secure the transducer between them. Note that several transducers use direction guides to allow correct mounting.

Smooth surface is important

Mounting screws or bolts must not be extruding from the transducer or the area immediately around it. Make sure that the surface of the transducer face, the installation hardware used to mount it, the hull plating and the putty around the transducer is as even and smooth as possible. Obstructions on these surfaces will create problems with turbulent flow.

Example: Acoustic window

The transducer shown in the figure below is mounted inside the tank behind a strong acoustic window which could be made of polycarbonate.

The tank is filled with oil.

Figure 34 Acoustic window

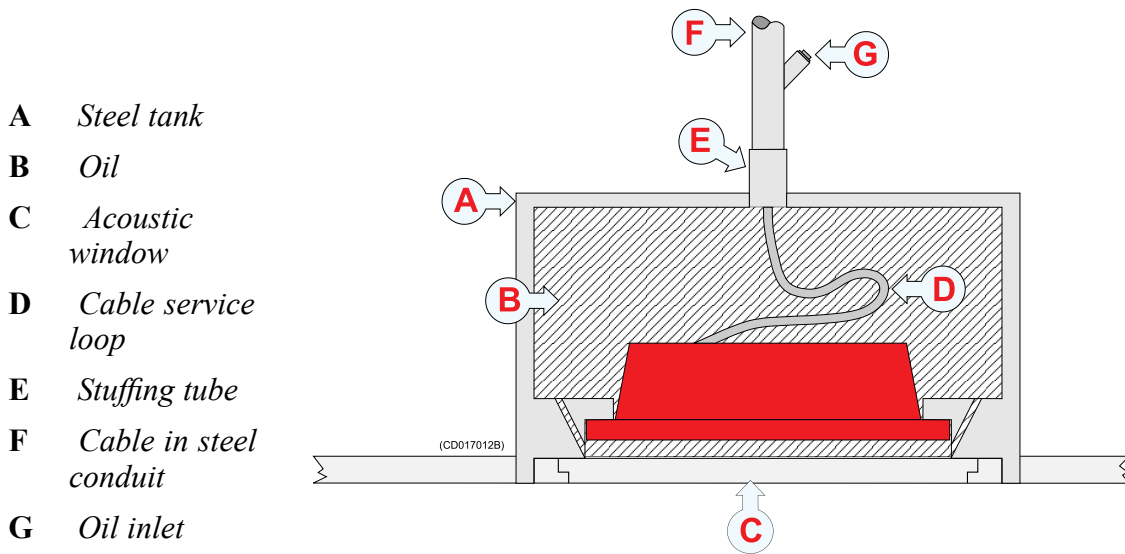

- A Steel tank
- B Oil
- C Acoustic window
- D Cable service loop
- E Stuffing tube
- F Cable in steel conduit
- G Oil inlet

Transducer mounted inside the hull

The transducer can also be mounted inside the hull.

An installation of the transducer inside the hull, and sounding through the hull, requires a good acoustic contact between the transducer face and the hull. Build a tank around the transducer and fill it with a liquid. Oil used in hydraulic systems is a well suited liquid for this purpose. It contains no gas bubbles and is non-corrosive.

Typical values of the two way loss are 3 dB for polyester, 6 dB for aluminium and 10 dB for steel. Hulls made of wood or a sandwich type with foam in the middle, attenuate the sound so much that through hull sounding must be regarded as impossible. The loss varies with the distance between transducer face and the hull. The best result is obtained when the distance is half a wavelength. Consult Simrad for advice. In addition to the loss, the beam pattern is degraded, because a larger area of the hull is set into vibrations.

Use mounting and clamping rings whenever provided

Circular transducers may be provided with mounting and clamping rings, or with drawings to allow for local production of these. The mounting ring is welded to the hole prepared for the transducer, while the clamping ring fits around the edge of the transducer body. Bolts through the clamping ring into the mounting ring will secure the transducer between them. Note that several transducers use direction guides to allow correct mounting.

Smooth surface is important

Mounting screws or bolts must not be extruding from the transducer or the area immediately around it. Make sure that the surface of the transducer face, the installation hardware used to mount it, the hull plating and the putty around the transducer is as even and smooth as possible. Obstructions on these surfaces will create problems with turbulent flow.

Example: Mounting inside the hull

The transducer shown in the figure below is mounted inside the hull. The tank is filled with oil.

Figure 35 Mounting inside the hull

- A Steel tank
- B Oil
- C Hull plating
- D Cable service loop
- E Stuffing tube
- F Cable in steel conduit
- G Hole for oil filling
- H Air outlet

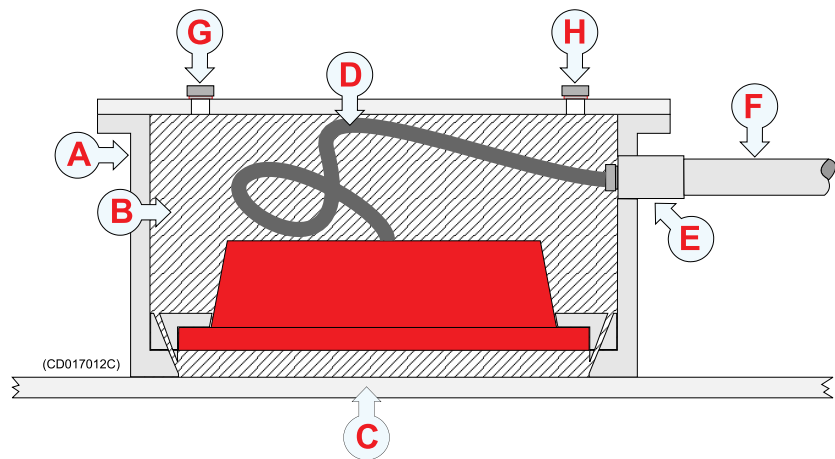

Transducer mounted on a drop keel

The use of a drop keel with the purpose of stabilising the vessel is well known.

A drop keel is also a superior platform for echo sounder transducers. Such instrument keels have been built, mainly on research vessels, often protruding as far as three meters below the hull. At that depth, the water is free of air bubbles up to very high sea states. The vessel is then able to perform reliable acoustic measurements in open sea a larger part of the year.

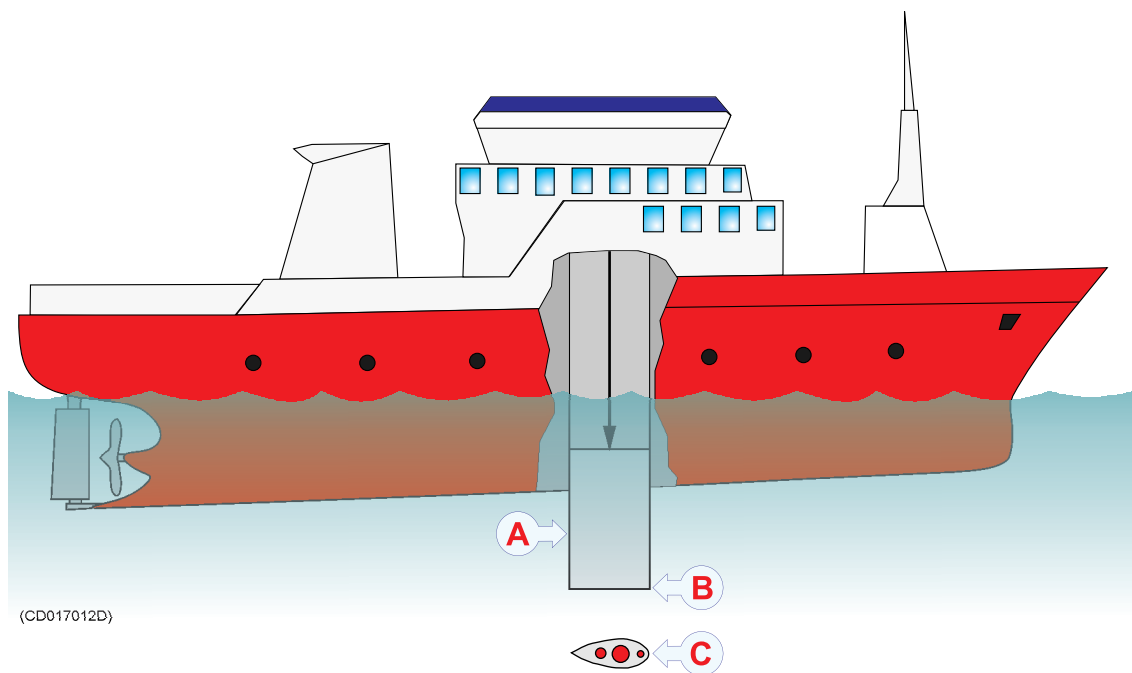

- A *Instrument keel shaft*
- B *Lowered position*
- C *Bottom view*

Retractable transducer

Hull units allowing the transducer to be lowered and hoisted are commonly used for horizontal looking sonars. When not in use, the transducer is retracted into a trunk.

The retractable hull unit is more expensive than a blister, but on vessels with a hull where it is difficult or impossible to install a blister, it may still be worth while. The principles of a hull unit with a retractable transducer is shown below.

Vessels without a keel and with a wide, flat bottom is an example where a retractable hull unit can be the only acceptable method for bringing the echo sounder transducer below the boundary layer.

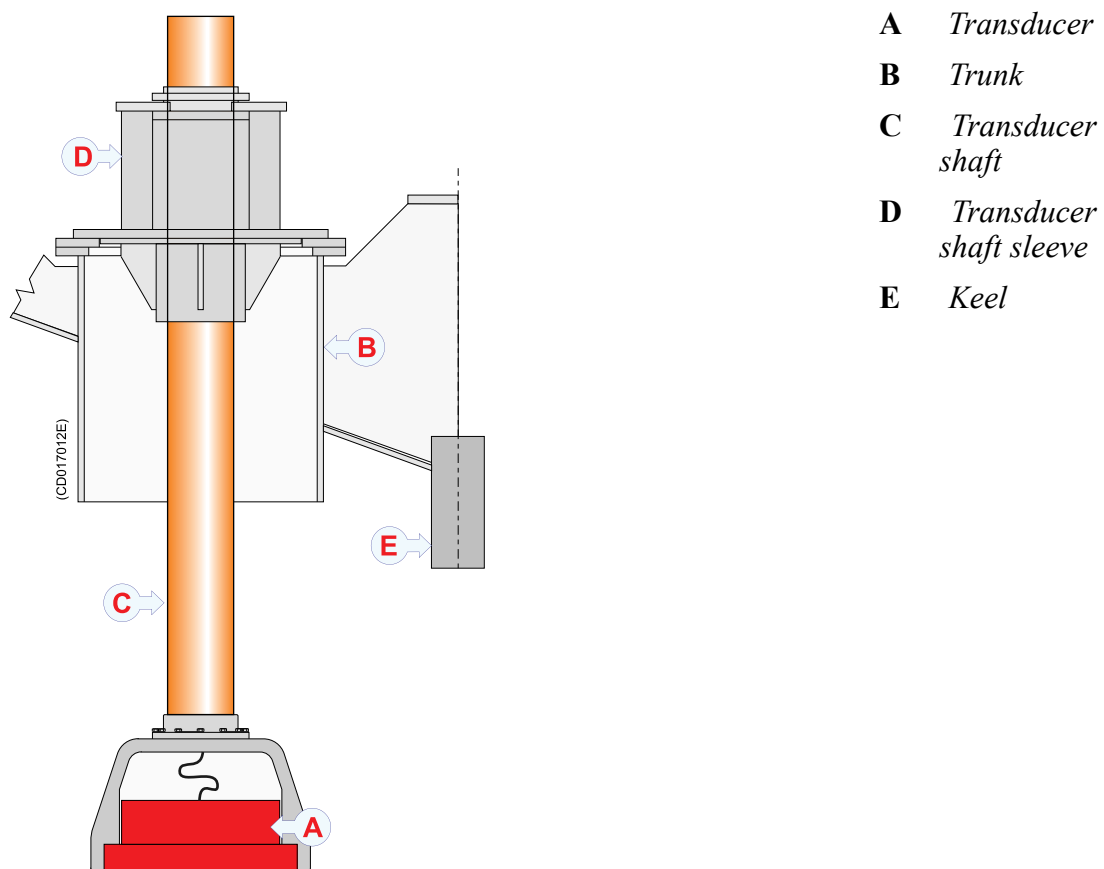

Towed body installation

Installation on a towed body

Transducers designed to withstand large water pressure are provided for use in towed bodies. The recommended installation method is through the hull plating hull using mounting and clamping rings. The installation arrangement on the towed body must be designed by the manufacturer of the towed body to fit its shape and characteristics.

Use mounting and clamping rings whenever provided

Circular transducers may be provided with mounting and clamping rings, or with drawings to allow for local production of these. The mounting ring is welded to the hole in the towed array, while the clamping ring fits around the edge of the transducer body. Bolts through the clamping ring into the mounting ring will then secure the transducer between them. Note that all split-beam transducers use direction guides to allow correct mounting.

Smooth surface is important

Mounting screws or bolts must not be extruding from the vehicle. Ensure that the surface of the transducer face, the vehicle, the vehicle plating and putty around the transducer is as even and smooth as possible. Obstructions on these surfaces will create problems with the water flow.

Small transducer

The illustration below shows the installation principle of a small circular transducer using clamping and mounting rings.

Figure 36 Installation principle, small transducer

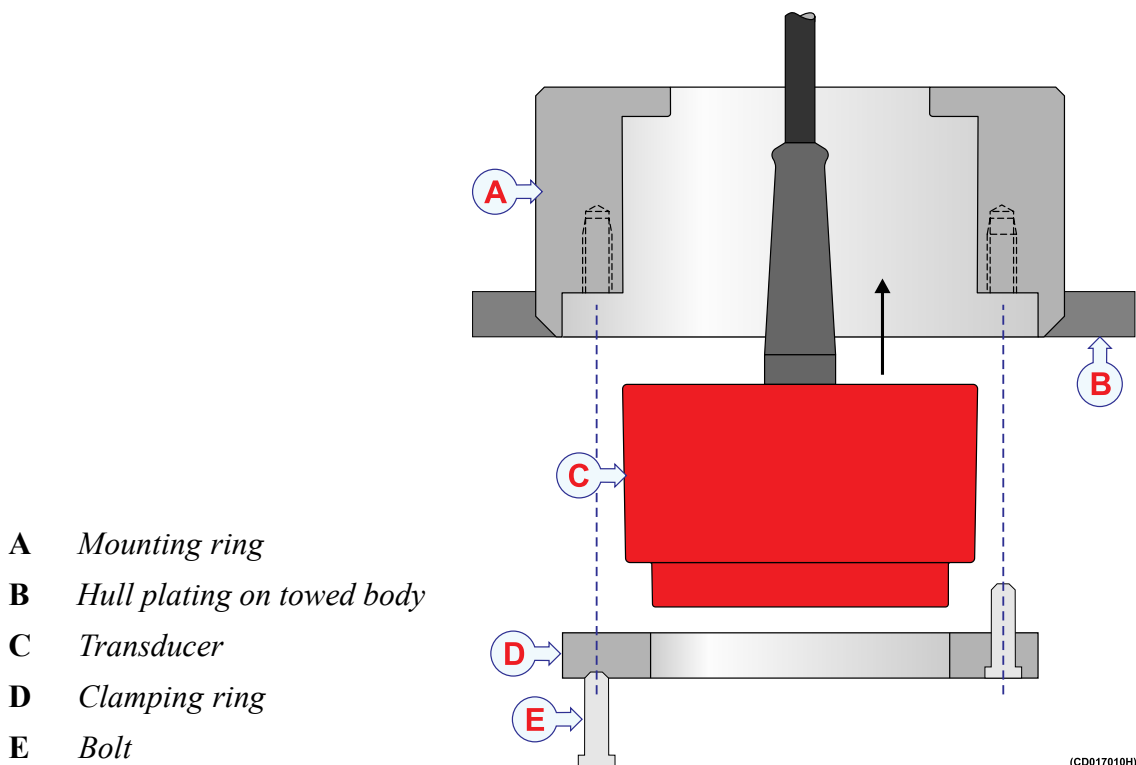

Medium and large transducers

The illustration below shows the installation principle of a medium or large transducers. Note that a clamping ring is not required, as the transducer body is shaped to facilitate this function.

Figure 37 Installation principle, medium and large transducers

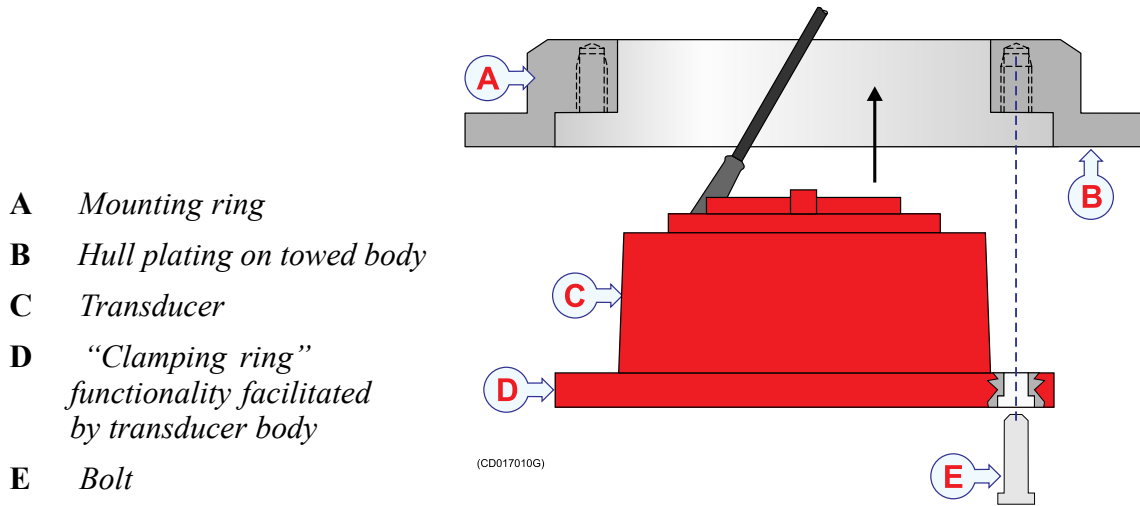

- A *Mounting ring*
- B *Hull plating on towed body*
- C *Transducer*
- D *“Clamping ring”
functionality facilitated
by transducer body*
- E *Bolt*

Dual transducer arrangement

The illustration below shows a typical through the hull installation of small and large circular transducers on a towed body.

Figure 38 Dual transducer arrangement

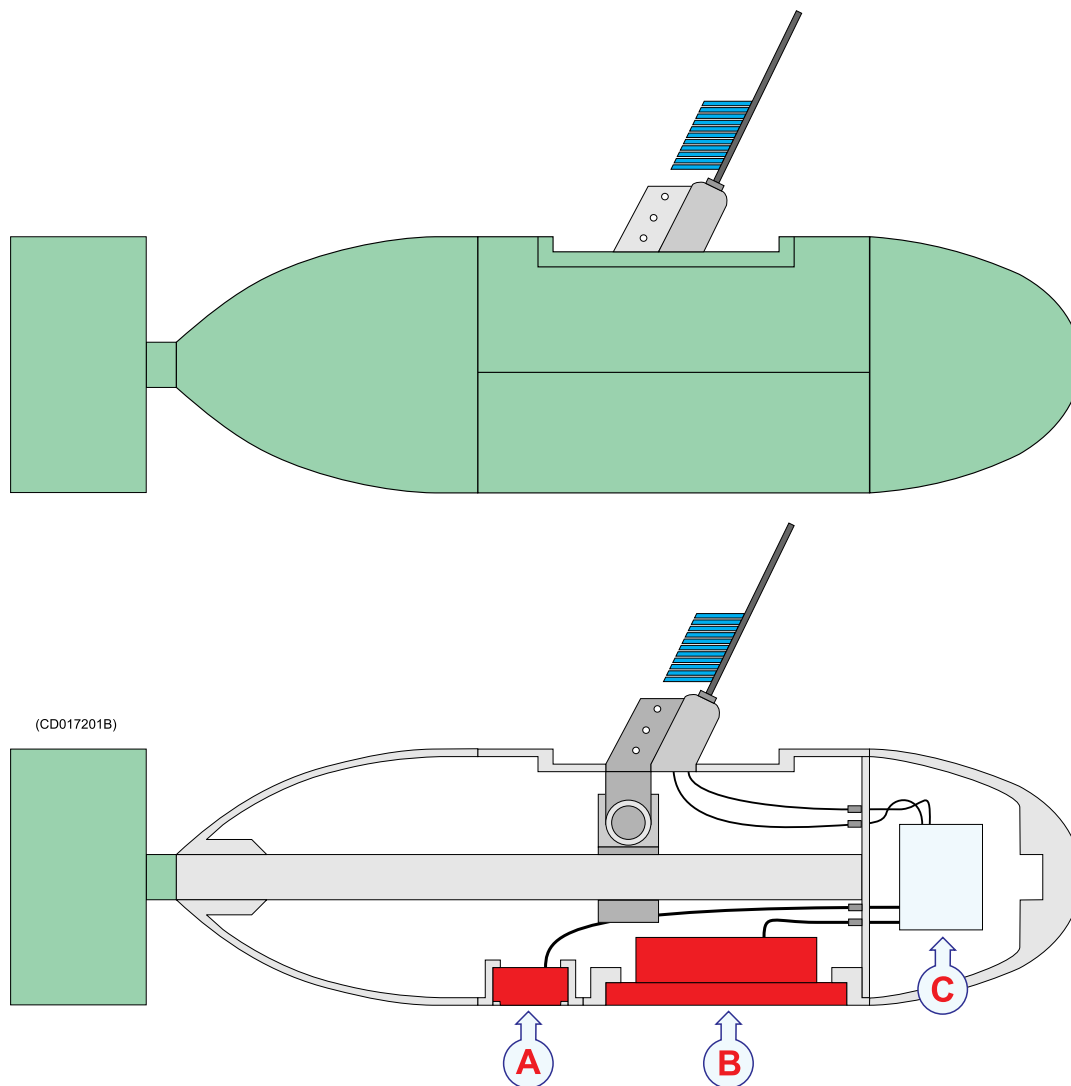

- A *Small transducer*
- B *Medium or larger transducer*
- C *Electronic equipment in watertight compartment*

Transducer cable glands and splicing

The transducer cable must pass through the hull using approved cable glands for the type of vessel in question.

About cable glands

A **steel** cable gland is normally used on professional vessels with steel hulls. A **bronze** cable gland can be delivered as an option for vessels with wood or fibreglass hulls. Vessel not to be classified can as an option use a cable gland made of **plastic**.

Note

Simrad strongly recommends that a length of conduit is fitted around transducer cable glands made of steel or bronze and extended over the water-line inside the vessel. This precaution reduces the danger of flooding in the event of gland failure and transducers installed in this manner are also easier to replace.

Some vessels may experience difficulties finding suitable areas of the hull for mounting transducer cable glands due to existing water tanks, concrete ballast or other obstacles. A possible solution in such cases is to run the transducer cables in a steel conduit aft along the hull until a suitable cable gland location is available. The respective cable gland can then be installed as described in the following instructions.

Note

Simrad takes no responsibility for the correct installation of cable glands, associated hull modifications and/or structural support of transducer cable penetration. These activities are subject to individual approval by the respective classification society for the vessel in question.

Cable gland for steel hulls

This cable gland kit is designed for steel vessels. It must be welded to the hull plates.

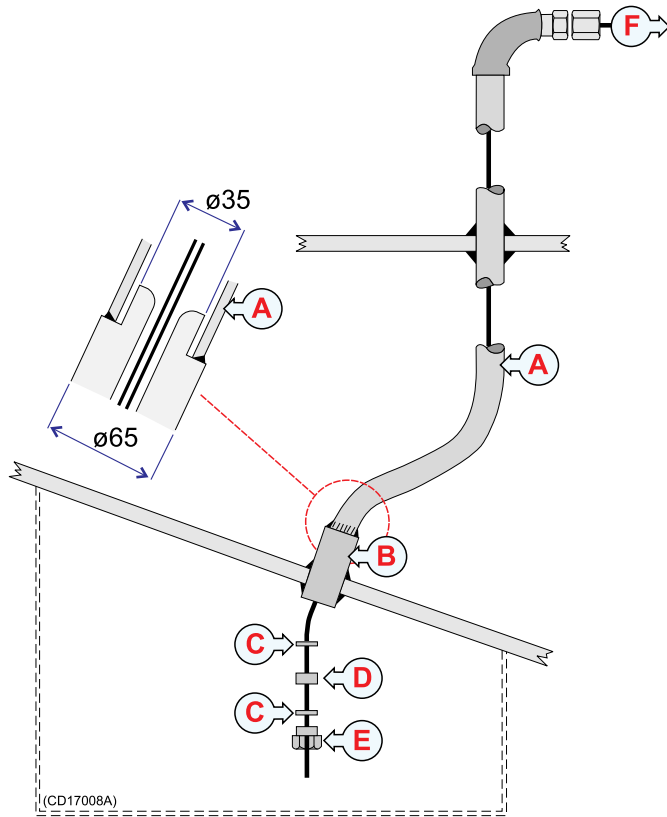

- A *Steel conduit*
- B *Stuffing tube, DNV approved carbon steel st52.3*
- C *Washers*
- D *Rubber gasket*
- E *Packing nipple. Make sure that you do not damage the transducer cable by tightening the packing nipple too hard!*
- F *Cable to the echo sounder (or a junction box)*

The cable gland kit includes all of the necessary parts needed to install the unit except screws.

Simrad recommends that a one inch steel conduit (that the transducer cable will be run through) with an inside threaded diameter of three-quarter inches is welded to the gland's stuffing tube. The conduit must extend to above the vessel's water line.

Cable gland for wooden and GRP hulls

A bronze cable gland kit is available for wooden and glass-reinforced plastic (GRP) vessels.

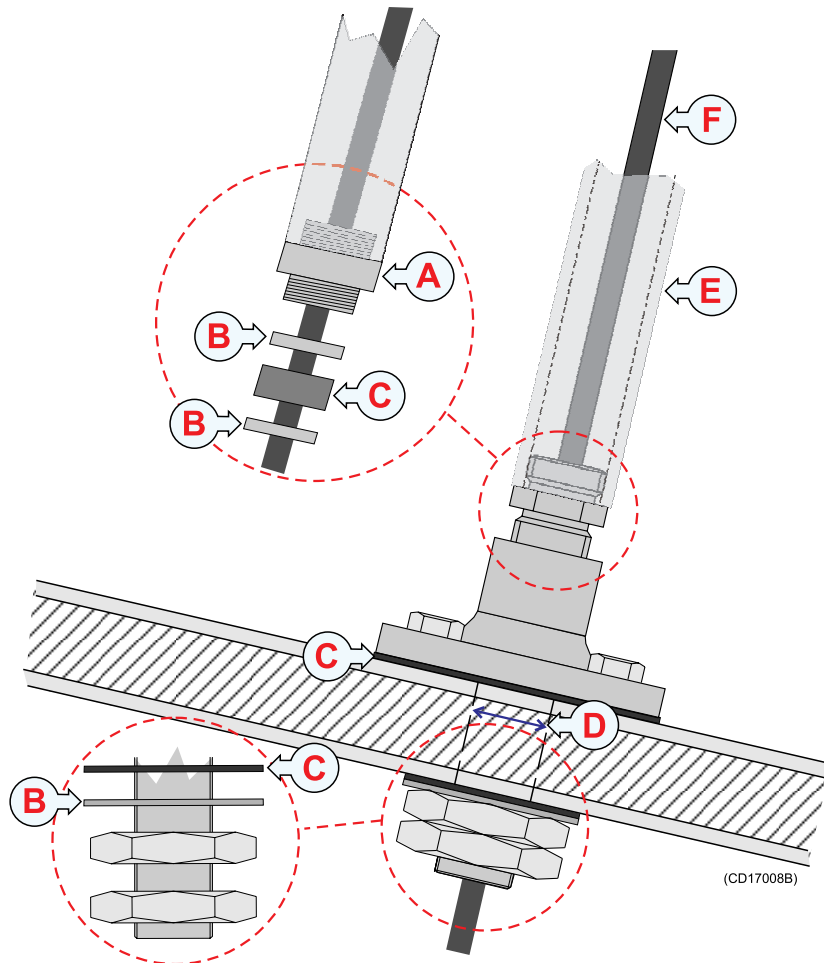

- A** *Packing nipple. Make sure that you do not damage the transducer cable by tightening the packing nipple too hard!*
- B** *Washers*
- C** *Rubber gaskets*
- D** *Hole diameter 28 mm*
- E** *Steel conduit*
- F** *Cable to the echo sounder (or a junction box)*

The cable gland kit includes all of the necessary parts needed to install the unit except screws.

Simrad recommends that a one inch steel conduit (that the transducer cable will be run through) with an inside threaded diameter of three-quarter inches is attached to the gland's packing nipple. This connection must be watertight, and the conduit must extend to above the vessel's water line.

Cable glands for small hulls

This cable glands made of plastic is designed for those smaller vessels that do not need to be classified.

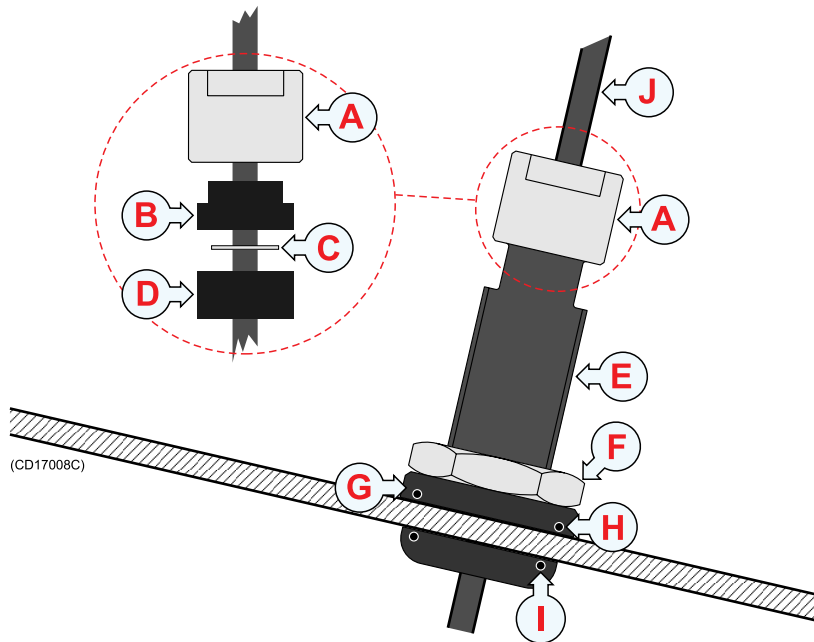

- A *Packing nut (bronze). Make sure that you do not to damage the transducer cable by tightening the packing nut too hard!*
- B *Rubber gasket*
- C *Plastic disk*
- D *Rubber gasket*
- E *Stuffing tube*
- F *Backing nut (bronze)*
- G *Backing washer (plastic)*
- H *O-ring 42.5 x 3.0 N*
- I *O-ring 39.5 x 3.0 N*
- J *Cable to the echo sounder (or a junction box)*

Stuffing tube hole diameter: 36 mm ±1.5 mm.

Apply ample amount of sealant between the backing washer (H) and the hull plate.

The cable gland kit contains all the listed parts, except the sealant.

Note

The two O-rings must be clean, in good condition and free of cuts or other defects which could affect their watertight integrity.

Transducer cable splicing

If you need to cut or lengthen the transducer cable, you must splice it correctly. The cable between the junction box and the transceiver must then be supplied by Simrad, and this must be the same type as used on the transducer(s). To splice the cable, use a metal junction box with EMC cable glands and a terminal block. The terminal block must provide solid fastening of the cable ends as well as sufficient insulation between the wires. We recommend that the cable screen is connected to the junction box chassis using the EMC cable glands, but if you do this, the junction box chassis must not be connected to vessel's ground.

Note

Do not solder the wires together with only electrical tape for insulation. This will result in electrical noise and reduced operational performance.

Do not connect the cable screen to the vessel's ground.

Order numbers

The cable glands described in this chapter are available as kits from Simrad. Observe the following order numbers.

Hull type	Item	Order number
Steel	Cable gland kit, steel, 8 to 15 mm cables	499-037763
Steel	Cable gland kit, steel, 17 to 18,5 mm cables	305609
Wood/GRP	Cable gland kit, bronze	119-038200
Small	Cable gland kit, plastic	599-202182

Steel conduit

Why use steel conduits?

It is strongly recommended to lay a steel conduit from the transducer's cable gland to the echo sounder transceiver, and to pull the transducer cable through this conduit. There are several reasons for this.

- It will make it easier at a later stage to replace the transducer.
- Noise and interference from other electrical equipment is greatly reduced.
- The risk of flooding is greatly reduced if the pipe is terminate above the water line.

With a steel conduit the installation will satisfy the EU regulations for EMC interference. Without a steel conduit, there is a risk of reduced echo sounder performance.

Steel conduits qualities and shielding

The steel conduit must be unbroken and watertight from the transducer to above the water line. From there, the cable can be pulled further, or a junction box can be installed to facilitate further connections. Note that the steel conduit must act as a continuous electrical screen all the way.

Steel conduit dimensions:

- minimum 35 mm inner diameter
- minimum 6 mm wall thickness (4.5 mm if galvanised)

More than one transducer cable?

If two or more transducers are installed close to each other it is possible to pull their cables in the same steel conduit, provided the conduit diameter is increased accordingly. However, for easy replacement it is recommended that each transducer has its own steel conduit.

Transducer handling and maintenance

You **MUST** observe the following rules for handling, maintenance and painting.

Rules for transducer handling

Note _____

Do not lift the transducer by the cable.

Do not expose the transducer to direct sunlight.

Do not expose the transducer to excessive heat.

Transport protection

Some transducers are delivered with a cover plate on the face for protection during transport. Let this plate stay on as long as possible, but do not forget to remove it before the vessel goes into the sea.

Painting the transducer face

An anti-fouling paint may be applied to the transducer face. Because some paint types may be aggressive to the polyurethane in the transducer face, please consult Simrad's list of approved paints. See *Approved anti-fouling paints for transducers* on page 144.

Cleaning the transducer face

Whenever opportunity arise, for example when the vessel is dry docked, the transducer face may be cleaned for shells and other marine fouling. Be careful not to make cuts in the transducer face. Use a piece of soft wood or a very fine grade emery paper.

Special rules for acoustic windows

Arctic tanks have acoustic windows made of polycarbonate. These must neither be painted nor cleaned with chemicals. Acoustic windows must not be exposed to direct sunlight.

Rules for transducer maintenance

Once installed, the transducer is maintenance free. However, when the vessel is docked, it is highly recommended to clean the transducer face to remove marine growth.

- 1 Perform a thorough visual check of the transducer.
- 2 If necessary, clean the transducer
 - To clean the transducer, use normal synthetic soap and water.
 - To remove marine growth, use fine-grade sandpaper or emery paper.

Note

Do not use strong solvents.

Do not attempt to scrape of marine growth with sheets of metal, screwdrivers or other metallic tools.

Do not use high pressure water to clean the transducer.

- 3 If necessary, apply a new layer of anti-fouling paint to the transducer face.
Because some paint types may be aggressive to the polyurethane in the transducer face, please consult Simrad's list of approved paints.
→ *Approved anti-fouling paints for transducers on page 144*

1

Approved anti-fouling paints for transducers

This is Simrad's list of approved antifouling paints on polyurethane transducer housing.

Jotun

Head office address: P.O.Box 2021, N-3248 Sandefjord, Norway

Website: www.jotun.com.

- 1 Racing
- 2 Non-stop
- 3 Safeguard Universal primer (125 micron) with Antifouling SeaQuantum Ultra (125 micron)
- 4 Antifouling Seaguardian

International Marine Coatings

Address: World-wide offices

Website: www.international-marine.com.

- 1 Intersleek tie coat + 425 FCS
 - BXA386/BXA390/BXA391 Grey
 - HKA563/HKA570/HKA571 Yellow
 - Mix BXA386, BXA390 and BXA391 first, then apply. When dry, mix HKA563, HKA570 and HKA571, apply.
- 2 Intersmooth 360 Ecoloflex SPC
- 3 Micron Extra

Hempel IFA Coatings

Head office address: Hempel A/S, Lundtoftevej 150, Kgs. Lyngby, DK-2800 Copenhagen, Denmark

Website: www.hempel.com.

- 1 Hempel A/F Classic 76550

Note

Refer to the manufacturer's documentation and data sheets for a complete procedure.

Using self-locking taps

Screw connections are generally made so that they can be loosened again. However, accidental loosening, especially under dynamic stress, must be avoided. For this reason it is often necessary to use additional locking devices. These are often expensive, they can be used once only, or react critically to temperature changes.

Introduction to Emuge self-locking threads

Emuge self-lock is a tap design with an integrated locking feature. Standard metric bolts are used. The internal thread provides a self-locking connection, which can be used repeatedly. It is not necessary to involve a secondary locking device (e.g. chemical, nylon or mechanical). The **Emuge self-lock** bolts withstand vibrations better than standard (metric) threads, because the thread contact stops the sideways movement. The special design of the internal thread profile also provides a more even distribution of the tightening stress over the whole thread length. The assembly is just as easy as with a normal (metric) thread. There is no general applicable standard (e.g. DIN standard) for the **Emuge self-lock** thread.

Figure 39 Example, internal and external threads

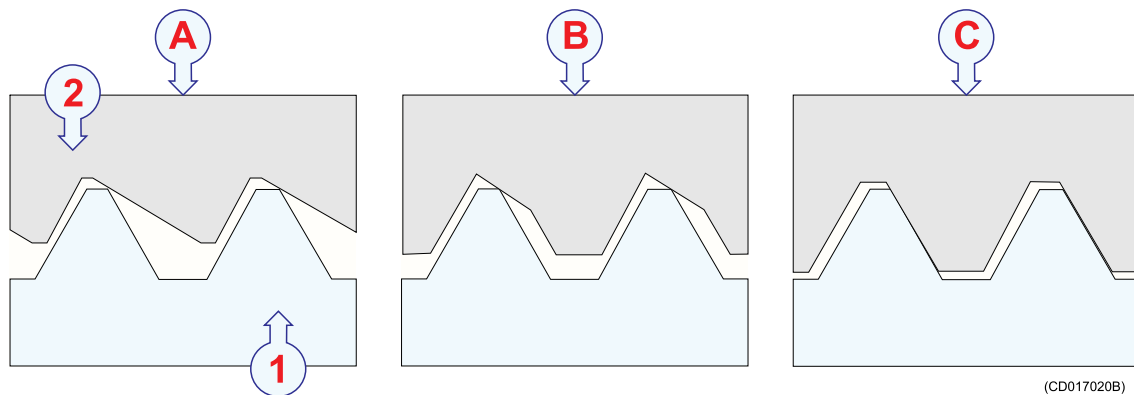

- A** *Emuge's saw-tooth profile up to pitch $P \leq 0.7$ mm*
- B** *Emuge's saw-tooth profile up to pitch $P \geq 0.7$ mm*
- C** *Standard thread*
- 1** *External thread*
- 2** *Internal thread*

Advantages

- The thread locking feature is integrated in the internal thread
- Modified profile with ramp surface in the direction of stress
- 30 degree ramp surface provides self-locking effect
- Easy assembly
- No assembly errors (forgetting the locking device) possible
- Use of standard external threads (screws) with tolerance class “medium”
- Even distribution of stress over the whole thread length
- No stripping of threads
- Economically efficient locking system, no additional components are necessary
- Undiminished holding power even under dynamic stress
- Repeated loosening and re-tightening without loss of function
- Internal threads can be produced with **Emuge** taps, cold forming taps or thread mills
- Larger thread hole diameters, i.e. increased tool life for threading tools
- Larger tolerances for thread hole diameters

Drawing standard

Whenever self-locking threads are required, this is shown on the technical drawing. In the case of tapping through holes, the arrow at the end of the center line illustrates the screw-in direction of the bolt.

Figure 40 Drawing examples, self-locking thread

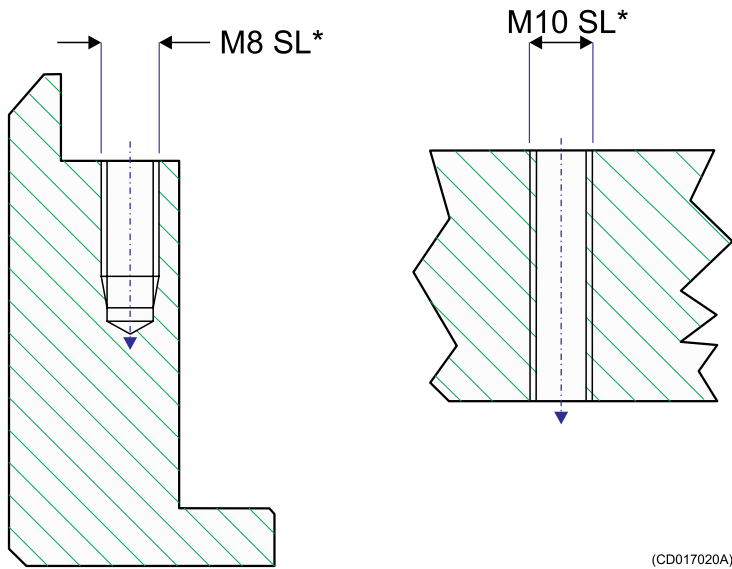

(CD017020A)

The drawing is normally provided with the following text (or similar):

Note: The self-lock threads marked with SL must be made in accordance with procedure 842–202125. Drill diameters for threads differ from standard. Self-lock taps can be supplied by Simrad.*

Taps and gauges

The pretension locking thread self-lock (taps) from manufacturer **Emuge** must be used.

Figure 41 Example of use

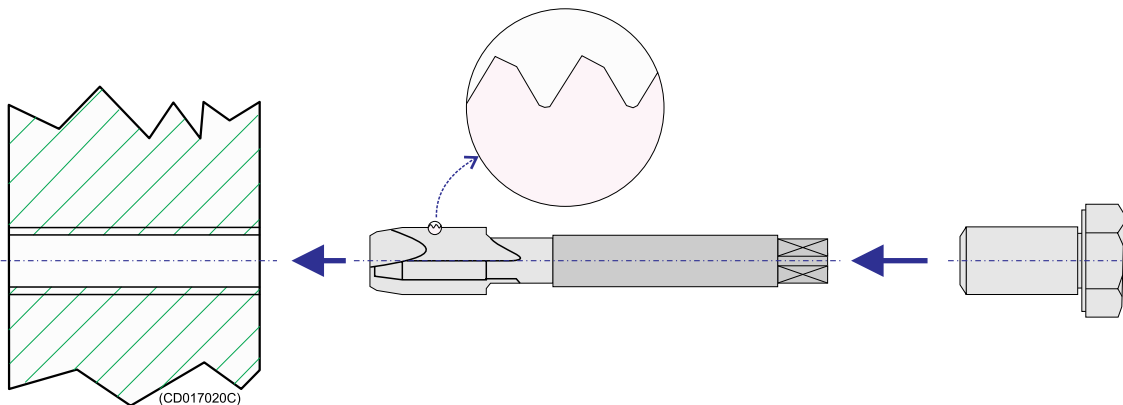

(CD017020C)

Note

*In the case of tapping through holes it is important that the profile of the **Emuge self-lock** threads is in the correct direction compared with the entering direction of the bolt.*

Use **Emuge self-lock** gauges. Note that the gauge must be used in the correct direction.

Self-lock taps provided by Simrad

The following self-lock taps are on stock at Simrad, and can be ordered from us.

Threads	Drill diameter for threads	Part.no
M6	ø5.2	700-078838
M8	ø7.0	700-078531
M10	ø8.8	700-078408
M12	ø10.7	700-078409
M16	ø14.5	700-078410

Supplier and manufacturer

Norwegian supplier is:

Tingstad AS, P.O.Box 83, Kalbakken, 0902 Oslo, Norway

<http://www.tingstad.no>

Manufacturer is:

EMUGE-Werk Richard Glimpel, Nurnberger Strasse 96-100, D-90607 Lauf, Germany

<http://www.emuge.de>

Simrad transducers

This chapter presents a list of all the current Simrad transducers. For each transducer, information is provided to establish:

- the transducer type and frequency
- the opening angle(s)
- the order number for the transducer
- the order number for the transducer cable
- how it is connected to the transceiver

This list was correct at the time of writing. However, new transducers are frequently added to the product range. For an updated list of all the currently available transducers, refer to www.simrad.com. Product specifications and installation documents can be downloaded from the web site.

Topics

- *All single beam transducers* on page 149
- *All split-beam transducers* on page 154

Related topics

- *Transducer cable splicing* on page 142
- *GPT Transducer plug connection* on page 107

All single beam transducers

The following single beam transducers are available.

Simrad 12-16/60

- **Type and frequency:** Single or dual beam, 12 kHz
- **Opening angle:** 16° or 60° (Passive)
- **Typical applications:** Fish finding, hydrographic and scientific echo sounders
- **Order number, transducer:** KSV-089510

- **Order number, transducer cable:** 642-022491
- **GPT connection:** *12-16/60 transducer* on page 72

Simrad 18–11

- **Type and frequency:** Single beam, 18 kHz
- **Opening angle:** 11°
- **Typical applications:** Fish finding and hydrographic echo sounders
- **Order number, transducer:** KSV-088693
- **Order number, transducer cable:** 642-016604
- **GPT connection:** *Single beam/normal power transducer* on page 64

Simrad 27-26/21

- **Type and frequency:** Dual beam, 27 kHz
- **Opening angle:** 10 x 11° or 10 x 20°
- **Typical applications:** Fish finding and hydrographic echo sounders
- **Order number, transducer:** KSV-067159
- **Order number, transducer cable:** 642-022491
- **GPT connection:** *Dual beam (wide or narrow) transducer* on page 66

Simrad 38-7

- **Type and frequency:** Single beam, 38 kHz
- **Opening angle:** 7°
- **Typical applications:** Fish finding and hydrographic echo sounders
- **Order number, transducer:** KSV-082776
- **Order number, transducer cable:** 642-016604
- **GPT connection:** *Single beam/normal power transducer* on page 64

Simrad 38-9

- **Type and frequency:** Single beam, 38 kHz
- **Opening angle:** 9°

- **Typical applications:** Fish finding and hydrographic echo sounders
- **Order number, transducer:** KSV-203635
- **Order number, transducer cable:** 642-016604
- **GPT connection:** *Single beam/normal power transducer* on page 64

Simrad 38/200 Combi D

- **Type and frequency:** Dual frequency single beam, 38 and 200 kHz
- **Opening angle:** 13 x 21° and 7 x 7°
- **Typical applications:** Fish finding and hydrographic echo sounders, Catch monitoring systems
- **Order number, transducer:** KSV-203004
- **Order number, transducer cable:** 642-078215
- **GPT connection:** *Dual frequency, single beam transducer* on page 69

Simrad 38/200 Combi W

- **Type and frequency:** Dual frequency single beam, 38 and 200 kHz
- **Opening angle:** 31 x 31° and 31 x 31°
- **Typical applications:** Fish finding echo sounders
- **Order number, transducer:** KSV-208845
- **Order number, transducer cable:** 642-078215
- **GPT connection:** *Dual frequency, single beam transducer* on page 69

Simrad 50-7

- **Type and frequency:** Single beam, 50 kHz
- **Opening angle:** 7°
- **Typical applications:** Fish finding and hydrographic echo sounders
- **Order number, transducer:** KSV-203665
- **Order number, transducer cable:** 642-016604
- **GPT connection:** *Single beam/normal power transducer* on page 64

Simrad 50-18

- **Type and frequency:** Single beam, 50 kHz
- **Opening angle:** 18°
- **Typical applications:** Hydrographic echo sounders
- **Order number, transducer:** KSV-082606
- **Order number, transducer cable:** 642-016604
- **GPT connection:** *Single beam/normal power transducer* on page 64

Simrad 50-18POR

- **Type and frequency:** Single beam, 50 kHz, Portable
- **Opening angle:** 18°
- **Typical applications:** Hydrographic echo sounders, portable
- **Order number, transducer:** KSV-088073
- **Order number, transducer cable:**
- **GPT connection:** *Single beam/normal power transducer* on page 64

Simrad 50/200 Combi D

- **Type and frequency:** Dual frequency single beam, 50 and 200 kHz
- **Opening angles:** 10 x 16° and 7 x 7°
- **Typical applications:** Fish finding and hydrographic echo sounders, Catch monitoring systems
- **Order number, transducer:** KSV-203005
- **Order number, transducer cable:** 642-078215
- **GPT connection:** *Dual frequency, single beam transducer* on page 69

Simrad 120-25

- **Type and frequency:** Single beam, 120 khz
- **Opening angle:** 10°
- **Typical applications:** Fish finding and hydrographic echo sounders
- **Order number, transducer:** KSV-062615
- **Order number, transducer cable:** 642-016604

- **GPT connection:** *Single beam/normal power transducer* on page 64

Simrad 200-7C

- **Type and frequency:** Single beam, 200 kHz
- **Opening angle:** 7°
- **Typical applications:** Fish finding and hydrographic echo sounders
- **Order number, transducer:** KSV-203378
- **Order number, transducer cable:** 642-016604
- **GPT connection:** *Single beam/normal power transducer* on page 64

Simrad 200-7F

- **Type and frequency:** Single beam, 200 kHz
- **Opening angle:** 7°
- **Typical applications:** Hydrographic echo sounders
- **Order number, transducer:** KSV-065414
- **Order number, transducer cable:** 642-016604
- **GPT connection:** *Single beam/normal power transducer* on page 64

Simrad 200-7G

- **Type and frequency:** Single beam, 200 kHz
- **Opening angle:** 7°
- **Typical applications:** Hydrographic and scientific echo sounders, Portable
- **Order number, transducer:** KSV-210895
- **Order number, transducer cable:** 642-076492
- **GPT connection:** *Single beam/normal power transducer* on page 64

Simrad 200-28E

- **Type and frequency:** Single beam, 200 kHz
- **Opening angle:** 7°
- **Typical applications:** Fish finding and hydrographic echo sounders

- **Order number, transducer:** KSV-109178
- **Order number, transducer cable:** 642-016604
- **GPT connection:** *Single beam/normal power transducer* on page 64

Simrad 200-35

- **Type and frequency:** Single beam, 200 kHz
- **Opening angle:** 3°
- **Typical applications:** Hydrographic echo sounders
- **Order number, transducer:** KSV-068181
- **Order number, transducer cable:** 642-016604
- **GPT connection:** *Single beam/normal power transducer* on page 64

Simrad 710-36E

- **Type and frequency:** Single beam, 710 kHz
- **Opening angle:** 2,8°
- **Typical applications:** Hydrographic and scientific echo sounders
- **Order number, transducer:** KSV-089292
- **Order number, transducer cable:** 642-016604
- **GPT connection:** *Single beam/normal power transducer* on page 64

All split-beam transducers

The following split-beam transducers are available.

Simrad ES18

- **Type and frequency:** Split beam, 18 kHz
- **Opening angle:** 11°
- **Typical applications:** Fish finding and scientific echo sounders
- **Order number, transducer:** KSV-088694
- **Order number, transducer cable:** 642-075072
- **GPT connection:** *Split beam transducer* on page 67

Simrad ES38-10

- **Type and frequency:** Split beam, 38 kHz
- **Opening angle:** 10°
- **Typical applications:** Fish finding echo sounders
- **Order number, transducer:** KSV-202714
- **Order number, transducer cable:** 642-078215
- **GPT connection:** *ES38-10 transducer* on page 70

Simrad ES38-12

- **Type and frequency:** Split beam, 38 kHz
- **Opening angle:** 12°
- **Typical applications:** Fish finding and scientific echo sounders
- **Order number, transducer:** KSV-111497
- **Order number, transducer cable:** 642-078215
- **GPT connection:** *Split beam transducer* on page 67

Simrad ES38B

- **Type and frequency:** Split beam, 38 kHz
- **Opening angle:** 7°
- **Typical applications:** Fish finding and scientific echo sounders
- **Order number, transducer:** KSV-074531
- **Order number, transducer cable:** 642-075072
- **GPT connection:** *Split beam transducer* on page 67

Simrad ES38DD

- **Type and frequency:** Split beam, 38 kHz
- **Opening angle:** 7°
- **Typical applications:** Scientific echo sounders, towed array
- **Order number, transducer:** KSV-113392

- **Order number, transducer cable:** Shipyard supply
- **GPT connection:** *Deep water, split beam transducer* on page 73

Simrad ES70-11

- **Type and frequency:** Split beam, 70 kHz
- **Opening angle:** 11°
- **Typical applications:** Fish finding and scientific echo sounders
- **Order number, transducer:** KSV-110280
- **Order number, transducer cable:** 642-075072
- **GPT connection:** *Split beam transducer* on page 67

Simrad ES70-7C

- **Type and frequency:** Split beam, 70 kHz
- **Opening angle:** 7°
- **Typical applications:** Fish finding and scientific echo sounders
- **Order number, transducer:** KSV-203678
- **Order number, transducer cable:** 642-078215
- **GPT connection:** *Split beam transducer* on page 67

Simrad ES120-7

- **Type and frequency:** Split beam, 120 khz
- **Opening angle:** 7°
- **Typical applications:** Fish finding and scientific echo sounders
- **Order number, transducer:** KSV-088277
- **Order number, transducer cable:** 642-075072
- **GPT connection:** *Split beam transducer* on page 67

Simrad ES120-7C

- **Type and frequency:** Split beam, 120 khz
- **Opening angle:** 7°

- **Typical applications:** Fish finding and scientific echo sounders
- **Order number, transducer:** KSV-204580
- **Order number, transducer cable:** 642-078215
- **GPT connection:** *Split beam transducer* on page 67

Simrad ES120-7DD

- **Type and frequency:** Split beam, 120 khz
- **Opening angle:** 7°
- **Typical applications:** Scientific echo sounders, towed array
- **Order number, transducer:** KSV-112417
- **Order number, transducer cable:** Shipyard supply
- **GPT connection:** *Deep water, split beam transducer* on page 73

Simrad ES120-7F

- **Type and frequency:** Split beam, 120 khz
- **Opening angle:** 7°
- **Typical applications:** Fish finding and scientific echo sounders
- **Order number, transducer:** KSV-110553
- **Order number, transducer cable:** 642-078215
- **GPT connection:** *Split beam transducer* on page 67

Simrad ES120-7G

- **Type and frequency:** Split beam, 120 khz
- **Opening angle:** 7°
- **Typical applications:** Scientific echo sounders
- **Order number, transducer:** KSV-112101
- **Order number, transducer cable:** 642-078215
- **GPT connection:** *Split beam transducer* on page 67

Simrad ES120-2,5x10

- **Type and frequency:** Split beam, 120 kHz
- **Opening angle:** 2,5 x 9,5°
- **Typical applications:** Scientific echo sounders
- **Order number, transducer:** KSV-111154
- **Order number, transducer cable:** 642-078215
- **GPT connection:** *Split beam transducer* on page 67

Simrad ES120-4x10

- **Type and frequency:** Split beam, 120 kHz
- **Opening angle:** 4,4 x 9°
- **Typical applications:** Scientific echo sounders
- **Order number, transducer:** KSV-203004
- **Order number, transducer cable:** 642-078215
- **GPT connection:** *Split beam transducer* on page 67

Simrad ES200-7

- **Type and frequency:** Split beam, 200 kHz
- **Opening angle:** 7°
- **Typical applications:** Fish finding and scientific echo sounders
- **Order number, transducer:** KSV-202718
- **Order number, transducer cable:** 642-075072
- **GPT connection:** *Split beam transducer* on page 67

Simrad ES200-7C

- **Type and frequency:** Split beam, 200 kHz
- **Opening angle:** 7°
- **Typical applications:** Fish finding and scientific echo sounders
- **Order number, transducer:** KSV-203003
- **Order number, transducer cable:** 642-078215
- **GPT connection:** *Split beam transducer* on page 67

Simrad ES200-7CD

- **Type and frequency:** Split beam, 200 kHz
- **Opening angle:** 7°
- **Typical applications:** Scientific echo sounders, Towed body
- **Order number, transducer:** KSV-207134
- **Order number, transducer cable:** 642-078215
- **GPT connection:** *Deep water, split beam transducer on page 73*

Simrad ES333-7C

- **Type and frequency:** Split beam, 333 kHz
- **Opening angle:** 7°
- **Typical applications:** Scientific echo sounders
- **Order number, transducer:** 322598
- **Order number, transducer cable:** 642-078215
- **GPT connection:** *Split beam transducer on page 67*

Simrad ES333-7CD

- **Type and frequency:** Split beam, 333 kHz
- **Opening angle:** 7°
- **Typical applications:** Scientific echo sounders, Towed body
- **Order number, transducer:** 312902
- **Order number, transducer cable:** 642-078215
- **GPT connection:** *Deep water, split beam transducer on page 73*

Telegram formats

This chapter describes the external NMEA and proprietary telegram interfaces supported by the ES70 Fish finding echo sounder. The chapter includes information about the telegram formats used to communicate with external peripherals and other computer systems.

Topics

- *NMEA telegrams* on page 160
- *Proprietary telegrams and formats* on page 167
- *Proprietary third party telegrams and formats* on page 174

NMEA telegrams

The following NMEA telegrams are supported by the ES70 Fish finding echo sounder.

Topics

- *About the NMEA telegram format* on page 161
- *DBS Depth below surface* on page 161
- *DBT Depth below transducer* on page 162
- *DPT Depth* on page 162
- *GGA Global positioning system fix data* on page 163
- *GLL Geographical position latitude/longitude* on page 163
- *HDM Heading, magnetic* on page 164
- *HDG Heading, deviation and variation* on page 164
- *HDT Heading, true* on page 165
- *RMC Recommended minimum specific GNSS data* on page 165
- *VHW Water speed and heading* on page 165
- *VLW Dual ground/water distance* on page 166
- *VTG Course over ground & ground speed* on page 166

About the NMEA telegram format

The Simrad ES70 can send and receive information to and from several different peripherals. All transmissions take place as **telegrams** with data sentences. Each telegram has a defined format and length.

The **NMEA 0183** standard is the most common protocol used to receive and transmit data to and from peripheral sensors. A parametric sentence structure is used for all NMEA data. The sentence start with a "\$" delimiter, and represent the majority of approved sentences defined by the standard. This sentence structure, with delimited and defined data files, is the preferred method for conveying information.

The following provides a summary explanation of the approved parametric sentence structure.

```
$aacc,c-c*hh<CR><LF>
```

For more information about the NMEA standard, the format and the data sentences, refer to their official publications. Their document *NMEA 1083 - Standard for interfacing marine electronic devices* explains the formats in detail. The document can be obtained from <http://www.nmea.org>.

Note

In some telegrams received from other Simrad equipments, the \$ character is replaced by the @ character. The checksum field may then not be in use.

- 1 "\$": *Start of sentence* (Hex: 24).
- 2 **aacc**: *Address field*. The first two characters (**aa**) identifies the *Talker ID*, while the last three characters are the *Sentence formatter* mnemonic code identifying the data type and the string format of the successive fields.
- 3 " , " : *Field delimiter* (Hex: 2C). This character starts each field except the address and checksum fields. If it is followed by a null field, it is all that remains to indicate no data in the field.
- 4 **c—c**: *Data sentence block*. This is a series of data fields containing all the data to be transmitted. The data field sentence is fixed and identified by the *Sentence formatter* in the address field. Data fields may be of variable lengths, and they are preceded by the *Field delimiter*.
- 5 " * " : *Checksum delimiter* (Hex: 2A). This delimiter follows the last field of the sentence, and indicates that the following two alphanumerical characters contain the checksum.
- 6 **hh**: *Checksum*
- 7 <CR><LF>: *Terminates sentence*

DBS Depth below surface

This telegram contains vessel heading in degrees magnetic. The telegram is no longer recommended for use in new designs.

It is often replaced by the **DPT** telegram.

Format

\$--DBS, x.x, f, y.y, M, z.z, F*hh<CR><LF>

Format description

- 1 -- = talker identifier
- 2 DBS = telegram identifier
- 3 x.x,f = depth below surface in feet
- 4 y.y,M = depth below surface in meters
- 5 z.z,F = depth below surface in fathoms

Related topics

- *How to set up the Simrad ITI Trawl system interface on page 87*
- *How to set up the Simrad PI Catch monitoring system interface on page 88*
- *How to set up the depth output on page 93*

DBT Depth below transducer

This telegram provides the water depth referenced to the transducer.

Format

\$--DBT, x.x, f, y.y, M, z.z, F*hh<CR><LF>

Format description

- 1 -- = talker identifier
- 2 DBT = telegram identifier
- 3 x.x,f = water depth in feet
- 4 y.y,M = water depth in meters
- 5 z.z,F = water depth in fathoms

DPT Depth

This telegram contains water depth relative to the transducer and offset of the measuring transducer. Positive offset numbers provide the distance from the transducer to the water line. Negative offset numbers provide the distance from the transducer to the part of the keel of interest.

For additional details, refer to the NMEA standard.

Format

\$--DPT, x.x, y.y, z.z*hh<CR><LF>

Format description

- 1 -- = talker identifier

- 2 **DPT** = telegram identifier
- 3 **x.x** = water depth, in meters, relative to the transducer
- 4 **y.y** = offset, in meters, from the transducer
- 5 **z.z** = maximum range scale in use

GGA Global positioning system fix data

This telegram contains time, position and fix related data from a global positioning system (GPS).

Format

```
$--GGA,hhmmss.ss,llll.ll,a,yyyyy.yy,a,
x,zz,d.d,a.a,M,g.g,M,r.r,cccc*hh<CR><LF>
```

Format description

- 1 -- = talker identifier
- 2 **GGA** = telegram identifier
- 3 **hhmmss.ss** = coordinated universal time (UTC) of position
- 4 **llll.ll,a** = latitude north/south, position in degrees, minutes and hundredths. Characters **N** (North) or **S** (South) identifies the bearing.
- 5 **yyyyy.yy,a** = longitude east/west, position in degrees, minutes and hundredths. Characters **W** (West) or **E** (East) identifies the bearing.
- 6 **x** = GPS quality indicator (refer to the NMEA standard for further details)
- 7 **zz** = number of satellites in use, 00 to 12, may be different from the number in view
- 8 **d.d** = horizontal dilution of precision
- 9 **a.a,M** = altitude related to mean sea level (geoid) in meters
- 10 **g.g,M** = geoidal separation in meters
- 11 **r.r** = age of differential GPS data
- 12 **cccc** = differential reference station identification, 0000 to 1023

GLL Geographical position latitude/longitude

This telegram is used to transfer latitude and longitude of vessel position, time of position fix and status from a global positioning system (GPS).

Format

```
$--GLL,llll.ll,a,yyyyy.yy,a,
hhmmss.ss,A,a*hh<CR><LF>
```

Format description

- 1 -- = talker identifier
- 2 **GLL** = telegram identifier.

- 3 **lll.ll,a** = latitude north/south, position in degrees, minutes and hundredths. Characters **N** (North) or **S** (South) identifies the bearing.
- 4 **yyyy.yy,a** = longitude east/west, position in degrees, minutes and hundredths. Characters **W** (West) or **E** (East) identifies the bearing.
- 5 **hhmmss.ss** = coordinated universal time (UTC) of position.
- 6 **A** = status, characters **A** (data valid) or **V** (data not valid) are used.
- 7 **a** = mode indicator.

HDG Heading, deviation and variation

This telegram contains the heading from a magnetic sensor, which if corrected for deviation will produce magnetic heading, which if offset by variation will provide true heading.

Format

\$--HDG, x.x, z.z, a, r.r, a*hh<CR><LF>

Heading conversions

- To obtain magnetic heading: Add easterly deviation (E) to magnetic sensor reading, or subtract westerly deviation (W) from magnetic sensor reading.
- To obtain true heading: Add easterly variation (E) to magnetic heading, or subtract westerly variation (W) from magnetic heading.

Format description

- 1 -- = talker identifier
- 2 **HDG** = telegram identifier
- 3 **x.x** = magnetic sensor heading, degrees
- 4 **z.z,a** = magnetic deviation, degrees east/west
- 5 **r.r,a** = magnetic variation, degrees east/west

HDM Heading, magnetic

This telegram contains vessel heading in degrees magnetic. The telegram is no longer recommended for use in new designs.

It is often replaced by the **HDG** telegram.

Format

\$--HDM, x.x, M*hh<CR><LF>

Format description

- 1 -- = talker identifier
- 2 **HDM** = telegram identifier
- 3 **x.x** = heading in degrees, magnetic

HDT Heading, true

This telegram is used to transfer heading information from a gyro.

Format

```
$--HDT, x.x, T*hh<CR><LF>
```

Format description

- 1 -- = talker identifier
- 2 HDT = telegram identifier
- 3 x.x,T = heading, degrees true

RMC Recommended minimum specific GNSS data

This telegram contains time, date, position, course and speed data provided by a global navigation satellite system (GNSS) receiver.

Format

```
$--RMC, hhmmss.ss, A, llll.ll, a, yyy.yy, a, x.x, z.z, ddmmyy, r.r, a, a*hh<CR><LF>
```

Format description

- 1 -- = talker identifier
- 2 RMC = telegram identifier
- 3 hhmmss.ss = coordinated universal time (UTC) of position fix
- 4 A = status, characters A (data valid) or V (Navigation receiver warning) are used.
- 5 lll.l,a = latitude nort/south. Characters N (North) or S (South) identifies the bearing.
- 6 yyy.yy.a = longitude east/west. Characters E (East) or W (West) identifies the bearing.
- 7 x.x = speed over ground, knots
- 8 z.z = course over ground, degrees true
- 9 ddmmyy = date
- 10 r.r,a = magnetic variation, degrees east/west. Characters E (East) or W (West) identifies the bearing.
- 11 a = mode indicator

VHW Water speed and heading

This telegram contains the compass heading to which the vessel points and the speed of the vessel relative to the water.

Format

```
$--VHW, x.x, T, x.x, M, x.x, N, x.x, K*hh<CR><LF>
```

Format description

- 1 -- = talker identifier
- 2 VHW = telegram identifier
- 3 x.x,T = heading, degrees true
- 4 x.x,M = heading, degrees magnetic
- 5 x.x,N = speed relative to water, knots, resolution 0.1
- 6 x.x,K = speed relative to water, km/hr, resolution 0.1

VLW Dual ground/water distance

This telegram contains the distance travelled relative to the water and over the ground.

Format

\$--VLW, x.x, N, y.y, N, z.z, N, g.g, N*hh<CR><LF>

Format description

- 1 -- = talker identifier
- 2 VLW = telegram identifier
- 3 x.x,N = total cumulative water distance, nautical miles.
- 4 y.y,N = water distance since reset, nautical miles.
- 5 z.z,N = total cumulative ground distance, nautical miles.
- 6 g.g,N = ground distance since reset, nautical miles.

VTG Course over ground & ground speed

This telegram contains the actual course and speed relative to the ground.

Format

\$--VTG, x.x, T, y.y, M, z.z, N, g.g, K, a*hh<CR><LF>

Format description

- 1 -- = talker identifier
- 2 VTG = telegram identifier
- 3 x.x,T = course over ground, degrees true
- 4 y.y,M = course over ground, degrees magnetic
- 5 z.z,N = speed over ground, knots, resolution 0.1
- 6 g.g,K = speed over ground, km/hr, resolution 0.1
- 7 a = mode indicator

Proprietary telegrams and formats

The following proprietary Simrad telegrams are supported by the ES70 Fish finding echo sounder.

Topics

- *Simrad EK500 Depth* on page 167
- *Simrad EM Attitude 1000* on page 168
- *Simrad EM Attitude 3000* on page 169
- *DBS Depth of trawl below surface* on page 170
- *HFB Trawl headrope to footrope and bottom* on page 170
- *PSIMP.D PI Sensor data* on page 171
- *PSIMDHB Bottom hardness and biomass* on page 172
- *Sounder/TSS1 Motion protocol* on page 173
- *Simrad ATS Annotation* on page 174

Simrad EK500 Depth

This proprietary Simrad telegram was defined for the EK500 scientific echo sounder. It provides the current depth from three channels, as well as the bottom surface backscattering strength and the athwartships bottom slope. This telegram has been defined for output on either a serial line or a local area network Ethernet connection.

Serial line format

D#, hhmsstt, x.x, y.y, t, s.s<CR><LF>

Serial line format description

- 1 **D#** = identifier, can be **D1**, **D2** or **D3** for channels 1, 2 or 3.
- 2 **hhmsstt** = current time; hour, minute, second and hundredth of second
- 3 **x.x** = detected bottom depth in meters
- 4 **y.y** = bottom surface backscattering strength in dB
- 5 **t** = transducer number
- 6 **s,s** = athwartships bottom slope in degrees

Ethernet format

The Ethernet line output is specified using a “C” programming language structure. Note that this format does not include carriage return and line feed characters at the end of the telegram.

```
struct Depth {
    char Header[2];
    char Separator1[1];
    char Time[8];
    char Separator1[2];
    float Depth[4];
}
```

```
float Ss[4];
long TransducerNumber[4];
float AthwartShips;
};
```

Ethernet format description

- 1 **Header#** = can be **D1**, **D2** or **D3** for channels 1, 2 or 3.
- 2 **Separator** = “,”
- 3 **Time** = current time; hour, minute, second and hundredth of second
- 4 **Depth** = detected bottom depth in meters
- 5 **Ss** = bottom surface backscattering strength in dB
- 6 **TransducerNumber** = transducer number
- 7 **AthwartShips** = athwartships bottom slope in degrees

Related topics

- *How to set up the depth output* on page 93

Simrad EM Attitude 1000

This proprietary **Kongsberg EM Attitude 1000** binary telegram consists of a fixed length message with 10 bytes.

It is defined as follows:

- Byte 1: Sync byte 1 = 00h
- Byte 2: Sync byte 2 = 90h
- Byte 3: Roll LSB
- Byte 4: Roll MSB
- Byte 5: Pitch LSB
- Byte 6: Pitch MSB
- Byte 7: Heave LSB
- Byte 8: Heave MSB
- Byte 9: Heading LSB
- Byte 10: Heading MSB

LSB = least significant byte, MSB = most significant byte.

- 1 All data are in 2's complement binary, with 0.01° resolution for roll, pitch and heading, and 1 cm resolution for heave.
 - Roll is positive with port side up with ±179.99° valid range
 - Pitch is positive with bow up with ±179.99° valid range
 - Heave is positive up with ±9.99 m valid range
 - Heading is positive clockwise with 0 to 359.99° valid range
- 2 Non-valid data are assumed when a value is outside the valid range.

- 3 You can define how roll is assumed to be measured, either with respect to the horizontal plane (the Hippy 120 or TSS convention), or to the plane tilted by the given pitch angle (i.e. as a rotation angle around the pitch tilted forward pointing x-axis). The latter convention (called Tate-Bryant in the POS/MV documentation) is used inside the system in all data displays and in logged data (a transformation is applied if the roll is given with respect to the horizontal).
- 4 Note that heave is displayed and logged as positive downwards (the sign is changed) including roll and pitch induced lever arm translation to the system's transmit transducer.
- 5 This format was originally designed for use with the EM 950 and the EM 1000 multibeam echo sounders with the first synchronisation byte always assumed to be zero. The sensor manufacturers was then requested to include sensor status in the format using the first synchronisation byte for this purpose. With this additional information added, the datagram format is known as **Kongsberg EM Attitude 3000**.

Related topics

- *How to set up the motion sensor interface* on page 92

Simrad EM Attitude 3000

This proprietary Kongsberg binary telegram consists of a fixed length 10-bytes message.

It is defined as follows:

- Byte 1: Sync byte 1 = 00h, or Sensor status = 90h-AFh
- Byte 2: Sync byte 2 = 90h
- Byte 3: Roll LSB
- Byte 4: Roll MSB
- Byte 5: Pitch LSB
- Byte 6: Pitch MSB
- Byte 7: Heave LSB
- Byte 8: Heave MSB
- Byte 9: Heading LSB
- Byte 10: Heading MSB

LSB = least significant byte, MSB = most significant byte.

- 1 All data are in 2's complement binary, with 0.01° resolution for roll, pitch and heading, and 1 cm resolution for heave.
 - Roll is positive with port side up with $\pm 179.99^\circ$ valid range
 - Pitch is positive with bow up with $\pm 179.99^\circ$ valid range
 - Heave is positive up with ± 9.99 m valid range
 - Heading is positive clockwise with 0 to 359.99° valid range
 Non-valid data are assumed when a value is outside the valid range.
- 2 You can define how roll is assumed to be measured, either with respect to the horizontal plane (the *Hippy 120* or *TSS* convention), or to the plane tilted by the

given pitch angle (i.e. as a rotation angle around the pitch tilted forward pointing x-axis). The latter convention (called *Tate-Bryant* in the *POS/MV* documentation) is used inside the system in all data displays and in logged data (a transformation is applied if the roll is given with respect to the horizontal).

- 3 Note that heave is displayed and logged as positive downwards (the sign is changed) including roll and pitch induced lever arm translation to the system's transmit transducer.
- 4 This format has previously been used with the EM 950 and the EM 1000 with the first synchronisation byte always assumed to be zero (Datagram "Kongsberg EM Attitude 1000"). The sensor manufacturers have been requested to include sensor status in the format using the first synchronisation byte for this purpose.

It is thus assumed that:

- **90h** in the first byte indicates a valid measurement with full accuracy
- any value from **91h** to **99h** indicates valid data with reduced accuracy (decreasing accuracy with increasing number)
- any value from **9Ah** to **9Fh** indicates non-valid data but normal operation (for example configuration or calibration mode)
- and any value from **A0h** to **AFh** indicates a sensor error status

Related topics

- *How to set up the motion sensor interface* on page 92

DBS Depth of trawl below surface

This proprietary Simrad telegram contains the depth of the trawl sensor.

Format

```
@I I D B S , , , x . x , M , , <CR><LF>
```

Format description

- 1 **II** = talker identifier (mandatory)
- 2 **DBS** = telegram identifier
- 3 **x.x,M** = depth in meters (0 to 2000)

Related topics

- *How to set up the Simrad ITI Trawl system interface* on page 87

HFB Trawl headrope to footrope and bottom

This proprietary Simrad telegram contains the distance from the headrope to the footrope, and from the footrope to the bottom.

Format

```
@I I H F B , x . x , M , y . y , M <CR><LF>
```

Format description

- 1 **II** = talker identifier (mandatory)
- 2 **HFB** = telegram identifier
- 3 **x.x,M** = distance from headrope to footrope, meters
- 4 **y.y, M** = distance from footrope to bottom, meters

Related topics

- *How to set up the Simrad ITI Trawl system interface on page 87*

PSIMP.D PI Sensor data

This proprietary Simrad telegram contains the type and configuration of PS and PI sensors used by the external PI catch monitoring system.

Format

```
$PSIMP,D,tt,dd,measure,unit,  
source,chan,val,crate,qual,infe,siglev,  
nlev,gain,cable, error*chksum<CR><LF>
```

Format description

- 1 **PS** = talker identifier (mandatory)
- 2 **IMP** = telegram identifier
- 3 **D** = Sentence specifier
- 4 **tt** = time of day
- 5 **dd** = current date
- 6 **measure** = measurement type:
 - D = Depth
 - T = Temperature
 - C = Catch
 - B = Bottom
 - N = No sensor
 - M = Marker
- 7 **unit** = unit – M, f or F for depth measurements, C or F for temperature measurements
- 8 **source** = source – number (1, 2 or 3) of the sensor providing the current data values
- 9 **chan** = channel – the number (1 to 30) of the communication channel for the current data source
- 10 **val** = value – the magnitude of the current sensor measurement
- 11 **crate** = change rate – the magnitude of the current depth or temperature measurement

12 qual = quality:

- 0 = No connection between the sensor and the receiver
- 1 = One or two telemetry pulses are lost, current value is predicted
- 2 = The current data value is reliable

13 infe = interference:

- 0 = No interference
- 1 = Interference detected

14 siglev = signal level – the signal level of the telemetry pulse, measured in dB // 1 µPa

15 nlev = noise level – the average noise level of the current channel, measured in dB // 1 µPa

16 gain = the current gain; 0, 20 or 40 dB.

17 cable = cable quality:

- 0 = cable is not connected
- 1 = cable is OK
- 2 = a short circuit, or the hydrophone current is too large

18 error = error detected – 0 when no error is detected, a number >0 indicates an error condition

19 checksum = The checksum field consists of a "*" and two hex digits representing the exclusive OR of all characters between, but not including, the "\$" and "*" characters

Related topics

- *How to set up the Simrad PI Catch monitoring system interface on page 88*

PSIMDHB Bottom hardness and biomass

This proprietary Simrad telegram contains the bottom hardness and biomass as calculated by an echo sounder.

Format

\$PSIMDHB, hhmmss.ss, t, f, KHZ, x.x, M, y.y, DB, z.z, , , <CR><LF>

Format description

- 1 \$P** = talker identifier (mandatory)
- 2 SIM** = Simrad talker ID
- 3 DHB** = coordinated universal time (UTC)
- 4 hhmmss.ss** = time
- 5 t** = transducer number
- 6 f,KHZ** = echo sounder frequency in kHz
- 7 x.x,M** = detected bottom depth in meters. Given as DBS (depth below surface), assuming proper transducer draft has been entered.
- 8 y.y,DB** = bottom surface hardness in dB

- 9 **z.z** = relative biomass density in m^2/nmi^2 (NASC) (s_A)
 NASC means Nautical Area Scattering Coefficient. This is the format ($s_A \text{ m}^2/\text{nmi}^2$) we provide the biomass data.
- 10 **spare1** = spare for future expansions
- 11 **spare2** = spare for future expansions

Sounder/TSS1 Motion protocol

This proprietary **Simrad Sounder/TSS1** protocol may be the most common interface for heave, roll and pitch compensation. When you select this protocol, the number of sensor variables is fixed, and there is no token associated with it. However, baud rate and output rate may be adjusted to fit your needs. The format is based on ASCII characters, the datagrams have fixed length, and it is terminated with a carriage return and line feed.

The definition of the attitude angles in this format is different from the *Euler* angles definition used elsewhere. The difference appears in the roll angle, where:

$$\text{Roll}_{\text{echosounder}} = \arcsin \left[\sin(\text{Roll}_{\text{Euler}}) \cdot \cos(\text{Pitch}_{\text{Euler}}) \right]$$

Format

```
:aabbbb shhhhxsrrrr spppp<cr><lf>
```

Format description

- 1 **aa** = sway – two characters hex number with sway acceleration, in 0.03835 m/ss units
- 2 **bbbb** = heave – four characters hex number with heave acceleration, in 0.000625 m/ss units
- 3 **s** = a single character providing a “space” character if the value is positive, or a “-” character if it is negative
- 4 **hhhh** = heave – four characters decimal number with heave position in centimetres, positive up
- 5 **x** = status character:
 - **U** = Unaided mode and stable data. The sensor operates without external input data.
 - **u** = Unaided mode but unstable data. The sensor is without external input data, but the data from the sensor is unstable. A probable cause for this is the lack of alignment after the sensor has been switched on restarted. The alignment period from a power recycle is normally approximately five minutes.
 - **G** = Speed aided mode and stable data. The sensor operates with external input of speed data.
 - **g** = Speed aided mode but unstable data. The sensor operates with external input of speed data, but the data from the sensor is unstable. A probable cause for this is the lack of alignment after the sensor has been switched on restarted, or a failure in the speed data input.

- **H** = Heading aided mode and stable data. The sensor operates with external input of heading data.
 - **h** = Heading aided mode but unstable data. The sensor operates with external input of heading data, but the data from the sensor is unstable. A probable cause for this is the lack of alignment after the sensor has been switched on restarted, or a failure in the heading data input.
 - **F** = Full aided mode and stable data. The sensor operates with external input of both speed and heading data.
 - **f** = Full aided mode but unstable data. The sensor operates with external input of heading and speed data, but the data from the sensor is unstable. A probable cause for this is the lack of alignment after the sensor has been switched on restarted, or a failure in the heading and/or speed data input.
- 6 **s** = a single character providing a “space” character if the value is positive, or a “-” character if it is negative
- 7 **rrrr** = roll – four character decimal number with roll angle in hundreds of a degree
- 8 **s** = a single character providing a “space” character if the value is positive, or a “-” character if it is negative
- 9 **pppp** = pitch – four character decimal number with pitch angle in hundreds of a degree

Related topics

- *How to set up the motion sensor interface* on page 92

Simrad ATS Annotation

This proprietary Simrad telegram contains a text string to be used for annotation purposes.

Format

```
$??ATS,tttt<CR><LF>
```

Format description

- 1 ?? = Talker identifier
- 2 ATS = telegram identifier
- 3 tttt = free text string

Proprietary third party telegrams and formats

The following proprietary third party telegrams are supported by the ES70 Fish finding echo sounder.

Topics

- *Atlas depth telegram* on page 175

Atlas depth telegram

This proprietary Atlas telegram contains the current depth from two channels.

Format

Dyxxxxxx.xxm

Format description

- 1 **Dy** = Channel number; **DA** is channel number 1, **DB** is channel number 2.
- 2 **xxxxx.xx** = depth in meters
- 3 **m** = meters

APPENDIX A — GENERAL SAFETY RULES

The Simrad ES70 Fish finding echo sounder system operates on 230 Vac 50/60 Hz.

WARNING

This voltage may be lethal!

The following safety precautions must be followed at all times during installation and maintenance work:

- Always switch off all power before installation or maintenance. Use the main circuit breaker, and label the breaker with a warning sign that informs others that maintenance or installation work is being carried out on the system.
- Do not open the rack or cabinet doors while in rough seas. It may swing open suddenly and cause damage or injury.
- For safety reasons during troubleshooting on the equipment with power ON, two persons must always be present.
- Read and understand the first aid instructions for electric shock.
- Whenever maintenance is carried out, it is essential that a first aid kit is available, and that the maintenance personnel are familiar with the first aid instructions for electrical shock.
- The various parts of the system are heavy. Make sure that the appropriate tools and certified lifting equipment are available, and that the personnel are trained in installation and maintenance work.

APPENDIX B — EQUIPMENT HANDLING

This section provides the basic rules for transportation, storage and handling of units. In this context, a unit may be any large or small part of the system. It can be supplied as part of the initial delivery, or as a spare part.

Transportation

Unless otherwise stated in the accompanying documentation, electronic, electro-mechanical and mechanical units supplied by Simrad can be transported using all methods approved for delicate equipment; (by road, rail, air or sea). The units are to be transported in accordance with general or specific instructions for the appropriate unit(s), using pallets, transport cases, or carton boxes as appropriate.

Note

Special local restrictions concerning air transportation may be applied to units containing certain types of batteries. These units must be checked properly, and the regulations must be investigated by the packer/shipper before the unit is dispatched.

All local transportation must be carried out according to the same specifications as for the initial delivery. In general, all units must be handled with care.

The carton or case containing the unit must be kept dry at all times, and must be sheltered from the weather. It must not be subjected to shocks, excessive vibration or other rough handling. The carton or case will normally be marked with text or symbols indicating which way it is to be placed. Follow any instructions given, and ensure the case is always placed with its “top” uppermost.

The carton or case must not be used for any purpose for which it was not intended (step, table, etc.), and in the absence of other information, no other cartons or cases must be stacked on top of it.

Lifting

A heavy crate will normally be marked with its weight, and the weights of other cartons or crates will normally be entered on the packing list.

- You must always check the weight of a crate before you attempt to lift it.
- You must always use lifting apparatus that is approved and certified for the load.

Heavy units may be equipped with lifting lugs for transportation by crane within the workshop or installation area. Before you use a crane:

- You must check the applicable weight certificate for the crane.
- You must check the security of the lifting lugs.

Ensure that all available lifting lugs are used. Ensure the unit remains under control during the operation to avoid damage to the unit, equipment or personnel.

Heavy units may be transported using a forklift truck. Special attention must then be paid to the position of the unit's centre of gravity. The units must be properly secured to the truck.

Storage prior to installation or use

When a system, a unit or a spare part has been delivered to the customer, it may be subject to long time storage prior to installation and use. During this storage period, certain specifications must be met. The equipment must be preserved and stored in such a way that it does not constitute any danger to health, environment or personal injury.

- 1 The equipment must be stored in its original transportation crate.
- 2 Ensure that the units are clearly separated in the shelves and that each unit is easily identifiable.
- 3 The crate must not be used for any purpose for which it was not intended (eg. work platform etc.).
- 4 The crates must not be placed on top of each other, unless specific markings permit this.
- 5 The crates must not be placed directly on a dirt-floor.
- 6 Do not open the crate for inspection unless special circumstances permit so.
 - “Special circumstances” may be suspected damage to the crate and its content, or inspections by civil authorities.
 - If any units are damaged, prepare an inspection report stating the condition of the unit and actions taken. Describe the damage and collect photographic evidence if possible. Re-preserve the equipment.
 - If the units are not damaged, check the humidity absorbing material. If required, dry or replace the bags, then re-pack the unit(s) according to the packing instructions.
- 7 If the crate has been opened, make sure that it is closed and sealed after the inspection. Use the original packing material as far as possible.
- 8 The storage room/area must be dry, with a non-condensing atmosphere. It must be free from corrosive agents.
- 9 The storage area's mean temperature must not be lower than -30°C , and not warmer than $+70^{\circ}\text{C}$. If other limitations apply, the crates will be marked accordingly.
- 10 The crate must not be exposed to moisture from fluid leakages.
- 11 The crate must not be exposed to direct sunlight or excessive warmth from heaters.
- 12 The crate must not be subjected to excessive shock and vibration.

- 13 If the unit contains normal batteries, these may have been disconnected/isolated before the unit was packed. These must only be reconnected before the installation starts. Units containing batteries are marked.

Caution

Units containing lithium or alkaline batteries must be handled separately and with care. Such units are marked accordingly. Do not attempt to recharge such batteries, open them or dispose of them by incineration. Refer to the applicable product data sheets.

Inspection

An inspection must be carried out immediately after the unit(s) have arrived at their destination.

- 1 Check all wooden or cardboard boxes, plastic bags and pallets for physical damage. Look for signs of dropping, immersion in water or other mishandling.
- 2 If damage is detected externally, you will have to open the packaging to check the contents. Request a representative of the carrier to be present while the carton is opened, so any transportation damage can be identified.
- 3 If any units are damaged, prepare an inspection report stating the condition of the unit and actions taken. Describe the damage and collect photographic evidence if possible. Send the inspection report to Simrad as soon as possible.
- 4 If the units are not damaged, check the humidity absorbing material. If required, dry or replace the bags, then re-pack the unit(s) according to the packing instructions.

Unpacking

General unpacking procedure

Normal precautions for the handling, transportation and storage of fragile electronic equipment must be undertaken.

Note

If the unit is not to be prepared for immediate use, you may consider storing it unopened in its original packing material. However, it may be useful to open the case to check its contents for damage and retrieve any accompanying documentation.

Do not use a knife to open cardboard cartons - the contents may lie close to the surface, and may be damaged by the blade.

- 1 Check the carton before opening it to ensure it shows no signs of dropping, immersion in water or other mishandling. If the carton shows signs of such damage, refer to the paragraph covering Inspection on receipt.
- 2 Place the carton on a stable work bench or on the floor with the top of the carton uppermost.
- 3 In the absence of other instructions, always open the top of the carton first. The contents will normally have been lowered into the carton from above, so this will usually be the easiest route to follow. Care must be used when opening the carton to ensure the contents are not damaged. Do not use a knife to open cardboard cartons
- 4 If the carton has been closed using staples, remove the staples from the carton as you open it. This will reduce the possibilities of scratch injury to yourself and damage to the contents.
- 5 If a wooden crate has been closed using screws, always remove them using a screwdriver. Do not attempt to prise the lid off with a crowbar or similar.
- 6 Once the carton is open, carefully remove all loose packing and insulation material. Check for manuals and other documents that may have been added to the carton during packing, and put these to one side. Check also for special tools, door keys etc.

Unpacking electronic and electromechanical units

Electronic and electromechanical units will normally be wrapped in a clear plastic bag. Lift the unit, in its bag, out of the carton and place it in a stable position on the floor/work bench.

Inspect the unit for damage before opening the plastic bag.

Note

Beware of the dangers of Electro-Static Discharge (ESD) both to yourself and to the equipment, when handling electronic units and components.

*Cables must **never** be used as carrying handles or lifting points.*

Do not break the seal to open a circuit board package before the board is to be used. If the board package is returned to the manufacturer with the seal broken, the contents will be assumed to have been used and the customer will be billed accordingly.

Assuming all is well, open the bag and remove the unit.

Open the unit and check inside. Remove any packing and desiccant material that may be inside.

Unpacking mechanical units

Mechanical units may be heavy. Using a suitably certified lifting apparatus, lift the unit out of the crate and place it in a stable position on the floor/work bench.

Inspect the unit for damage and remove any packing material that may be inside the unit.

Unpacking transducers

Transducers may be supplied mounted to a hull unit (if any), or packed separately. Crates are normally identified by the order number and the serial number.

The transducer face must be protected by a rigid, padded cover (e.g. a wooden box lined with foam rubber) all the time it is exposed to the risk of physical damage.

Caution

Once transducer is unpacked, great care must be taken to ensure that transducer body and cabling is not exposed to any mechanical stress.

Storage after unpacking

The unit must whenever possible be stored in its original transportation crate until ready for installation. The crate must not be used for any purpose for which it was not intended (eg. work platform etc.).

Once unpacked, the equipment must be kept in a dry, non condensing atmosphere, free from corrosive agents and isolated from sources of vibration.

Note

Do not break the seal to open a circuit board package before the board is to be used. If the board package is returned to the manufacturers with the seal broken, the contents will be assumed to have been used and the customer will be billed accordingly.

The unit must be installed in its intended operating position as soon as possible after unpacking. If the unit contains normal batteries, these may have been disconnected/isolated before the unit was packed. These must then be reconnected during the installation procedure. Units containing batteries are marked.

Note

Units containing lithium or alkaline batteries must be handled separately and with care. Such units are marked accordingly. Do not attempt to recharge such batteries, open them or dispose of them by incineration. Refer to the applicable product data sheets.

Storage after use

If a unit is removed from its operating location and placed into storage, it must be properly cleaned and prepared before packing.

Cleaning cabinets

If a cabinet has been exposed to salt atmosphere while it was in use, it must be thoroughly cleaned both internally and externally to prevent corrosion.

- 1 Wipe the cabinet externally using a damp cloth and a little detergent. Do not use excessive amounts of water as the unit may not be water tight. On completion, dry the unit thoroughly.
- 2 All surfaces must be inspected for signs of corrosion, flaking/bubbling paint, stains etc. Damaged or suspect areas must be cleaned, prepared and preserved using the correct preservation mediums for the unit. The mediums to be used will usually be defined in the units' maintenance manual.
- 3 Open the unit, and using a vacuum cleaner, remove all dust etc. from the unit. Great care must be taken to ensure the circuit boards and modules are not damaged in the process.

Mechanical units

If a mechanical unit may has been exposed to a salt atmosphere while it was in use, it must be thoroughly cleaned both internally and externally to prevent corrosion.

- 1 If the construction materials and type of unit permits, wash the unit using a high-pressure hose and copious amounts of fresh water. Examples are the lower parts of hull units (outside the hull) or subsea units
- 2 Ensure that all traces of mud and marine growth are removed. Use a wooden or plastic scraper to remove persistent growth, barnacles etc. On completion, dry the unit thoroughly.

Caution

*Do not use a high pressure hose in the vicinity of cables or transducers.
Do not use sharp or metal tools on a transducer face.*

- 3 If the materials or type of unit prevents the use of a high-pressure hose, wipe the unit using a cloth dampened with water containing a little detergent. Examples are the upper parts of hull units (inside the hull) and hydraulic systems
- 4 Do not use excessive amounts of water as some components on the unit may not be water tight. Wipe off the detergent with a damp cloth, then dry the unit thoroughly.
- 5 All surfaces must be inspected for signs of corrosion, flaking/bubbling paint, stains etc. Damaged or suspect areas must be cleaned, prepared and preserved using the correct preservation mediums. The mediums to be used will normally be defined in the unit's maintenance manual.

Cables

Wipe clean all exposed cables, and check for damage. If a cable shows signs of wear or ageing, contact Simrad for advice.

Internal batteries

If the unit contains batteries, these may discharge slowly during storage. If the unit is to be stored for an extended period, disconnect or remove all internal batteries.

A suitable piece of insulating material can be placed between the battery and the electrical contacts to prevent electrical discharge. The battery can then remain in the unit, reducing the risk of it being misplaced during the storage period.

Caution

Units containing lithium or alkaline batteries must be handled separately and with care. Such units are marked accordingly. Do not attempt to recharge such batteries, open them or dispose of them by incineration. Refer to the applicable product data sheets.

Dehumidifier

Place a suitably sized bag of desiccant material (silica gel or similar) into the unit to keep the electronic components as dry as possible.

Coatings

Spray the unit externally with a corrosion inhibitor (e.g. a light oil) before packing.

Re-packaging

Whenever possible, the unit must be stored and transported in its original packing material and/or crate. In the event that this material is not available, proceed as follows:

- Small units must be protected from damp by being placed within a plastic bag at least 0.15 mm thick. An appropriate quantity of desiccant material should be placed inside this bag, and the bag sealed. The sealed unit must then be placed in an appropriate carton or crate, and supported in the container by appropriate shock-absorbing insulation (polystyrene foam chips etc.).
- Large units must be placed in a suitable cardboard box or wooden crate. The unit must be protected against physical damage by means of shock-absorbing insulation mats. The box must be clearly marked with its contents, and must be stored in a dry and dust-free area.

Temperature protection

If the unit must be protected against extremes of temperature, the carton/crate must be lined on all walls, base and lid with 5 cm thick polyurethane or polystyrene foam. These units will be identified as delicate in the applicable documentation.

The package must then be clearly marked:

Must not be transported or stored in temperatures below -5 degrees Celsius.

Other units can normally be stored in temperatures between -30° C and +70° C, refer to the system's technical specifications for details.

Unless otherwise specified, transducers must not be stored in temperatures below -20° C and above +60° C.

Circuit board handling and packaging

Circuit boards are delicate items. They may work year after year in an advanced product, but then fail due to a small spark of static electricity. For this reason, it is very important that they are properly handled and protected during shipping.

Beware of ESD!

When you handle electronic circuit boards, you must beware of the dangers of electrostatic discharge (ESD), both to yourself and to the equipment. In order to ensure safe transport and storage, circuit boards and other electronic units will always be wrapped in a clear plastic protective bag, and the bag will be sealed. See also section *Electro-Static Discharge (ESD)* on page 185.

Unpacking and handling circuit boards

To unpack a circuit board:

- Wherever possible, prepare a suitable workbench. It must have an approved conductive service mat, and it must be connected directly to a reliable earth point via its earthing cord. You must wear a wristband in direct contact with the skin, and the wristband must be connected to the service mat.
- Lift the circuit board, in its protective bag, out of the carton and place it in a stable position on the a floor/work bench.
- Inspect the unit for damage before you open the plastic bag.
- Do not break the seal to open a circuit board package before the board shall to be used. If the board package is returned with the seal broken, we will assume that the content has been used, and we will bill you accordingly.
- Assuming all is well, open the bag and remove the unit.
- Take out and keep the documentation. You will need it if the circuit board shall be returned to us. Also, remove any packing and desiccant material that may be inside.
- Keep the protective plastic bag for future use.

Unpacking on board the vessel

When you are working on board a vessel, an “approved conductive service mat” is often far away. As you still need to unpack circuit boards, make sure that you do it in the instrument room, or at another location where you have a steel deck. Keep far away from the bridge or any other rooms with wall-to-wall carpets! If possible, bring a wristband and ground yourself.

Returning a circuit board

If you wish to return a circuit board to us, observe the following rules.

- Place the circuit board to be returned in the same protective plastic bag as you originally received it in - or a protective bag of similar ESD protection quality.
- DO NOT use standard plastic bags, such as commercial bubble wrap.
- Fill in all the necessary information on the applicable documentation and place it inside the bag.
- Seal the bag.
- Place the circuit board in a suitable carton, and secure it for shipping.

Note

Failure to follow these rules may result in unserviceable circuit boards.

Electro-Static Discharge (ESD)

What is ESD?

Electro-Static Discharge (ESD) is the transfer of an electrostatic charge between two bodies at different electrostatic levels, caused either by direct contact or induction by an electrostatic field. The passing of a charge through an electronic device can cause localised overheating, and it can also “puncture” insulating layers within the structure of the device. This may deposit a conductive residue of the vaporised metal on the device, and thus create a short circuit. This may result in a catastrophic failure, or degraded performance of the device.

ESD protection

Sensitive electronic circuit boards must be transported and stored in protective packing bags. The circuit boards must not be transported or stored close to strong electrostatic, electro-magnetic or radioactive fields.

If it is necessary to open and touch the circuit board inside the protective bag, then the following precautions must be taken:

- 1 The working area must be covered by an approved conductive service mat that has a resistance of between 50 k Ω and 2 M Ω , and is connected directly to a reliable earth point via its earthing cord.

- 2 The service personnel involved must wear a wristband in direct contact with the skin, connected to the service mat.
- 3 Printed circuit boards must be placed on the conductive service mat during installation, maintenance etc.
- 4 If, for any reason, it is necessary to move the circuit board from the conductive service mat, it must be placed in an approved antistatic transportation container (e.g. static shielding bag) before transportation.
- 5 During installation and servicing, all electrical equipment (soldering irons, test equipment etc.) must be earthed.

APPENDIX C — BASIC CABLE REQUIREMENTS

This chapter provides general information related to the installation of system cables.

Topics

- *Cable trays* on page 187
- *Radio Frequency interference* on page 188
- *Physical protection* on page 188
- *Grounding* on page 188
- *Cable connections* on page 189
- *Cable terminations* on page 189
- *Cable identification* on page 189

Cable trays

All permanently installed cables associated with the system must be supported and protected along their entire lengths using conduits and/or cable trays. The only exception to this rule is over the final short distance (maximum, 0,5 meters) as the cables run into the cabinets/units to which they are connected. These short service loops are to allow the cabinets to move on their shock mounts, and to allow maintenance and repair.

- Wherever possible, cable trays must be straight, accessible and placed so as to avoid possible contamination by condensation and dripping liquids (oil, etc.). They must be installed away from sources of heat, and must be protected against physical damage. Suitable shields must be provided where cables are installed in the vicinity of heat sources.
- Unless it is absolutely unavoidable, cables should not be installed across the vessel's expansion joints. If the situation is unavoidable, a loop of cable having a length proportional to the possible expansion of the joint must be provided. The minimum internal radius of the loop must be at least twelve times the external diameter of the cable.
- Where a service requires duplicate supply lines, the cables must follow separate paths through the vessel whenever possible.
- Signal cables must not be installed in the same cable tray or conduit as high-power cables.
- Cables containing insulation materials with different maximum-rated conductor temperatures should not be bunched together (that is, in a common clip, gland, conduit or duct). When this is impractical, the cables must be carefully arranged such that the maximum temperature expected in any cable in the group is within the specifications of the lowest-rated cable.
- Cables with protective coverings which may damage other cables should not be grouped with other cables.
- Cables having a copper sheath or braiding must be installed in such a way that galvanic corrosion by contact with other metals is prevented.

- To allow for future expansion of the system, all cables should be allocated spare conductor pairs. Also, space within the vessel should be set aside for the installation of extra cables.

Radio Frequency interference

All cables that are to be permanently installed within 9 m (30 ft) of any source of Radio Frequency (RF) interference such as a transmitter aerial system or radio transmitters, must, unless shielded by a metal deck or bulkhead, be adequately screened by sheathing, braiding or other suitable material. In such a situation flexible cables should be screened wherever possible.

It is important that cables, other than those supplying services to the equipment installed in a radio room, are not installed through a radio room, high power switch gear or other potential sources of interference. Cables which must pass through a radio room must be screened by a continuous metal conduit or trunking which must be bonded to the screening of the radio room at its points of entry and exit.

Physical protection

Cables exposed to the risk of physical damage must be enclosed in a steel conduit or protected by a metal casing unless the cable's covering (e.g. armour or sheath) is sufficient to protect it from the damage risk.

Cables exposed to an exceptional risk of mechanical damage (for example in holds, storage-spaces and cargo-spaces) must be protected by a suitable casing or conduit, even when armoured, if the cable covering does not guarantee sufficient protection for the cables.

Metallic materials used for the physical protection of cables must be suitably protected against corrosion.

Grounding

All metallic cable coverings (armour, metallic sheathing etc.) must be electrically connected to the vessel's hull at both ends except in the case of final sub-circuits where they should be connected at the supply end only.

Grounding connections should be made using a conductor which has a cross-sectional area appropriate for the current rating of the cable, or with a metal clamp which grips the metallic covering of the cable and is bonded to the hull of the vessel. These cable coverings may also be grounded by means of glands specially intended for this purpose

and designed to ensure a good ground connection. The glands used must be firmly attached to, and in good electrical contact with, a metal structure grounded in accordance with these recommendations.

Electrical continuity must be ensured along the entire length of all cable coverings, particularly at joints and splices. In no case should the shielding of cables be used as the only means of grounding cables or units.

Metallic casings, pipes and conduits must be grounded, and when fitted with joints these must be mechanically and electrically grounded locally.

Cable connections

All cable connections are shown on the applicable cable plan and interconnection diagrams.

Where the cable plan shows cable connections outside an equipment box outline, the connections are to be made to a plug or socket which matches the plug or socket on that particular item of equipment.

Where two cables are connected in series via a junction box or terminal block, the screens of both cables must be connected together but not grounded.

Cable terminations

Care must be taken to ensure that the correct terminations are used for all cable conductors, especially those that are to be connected to terminal blocks. In this case, crimped sleeve-terminations must be fitted to prevent the conductor core from fraying and making a bad connection with the terminal block. It is also of the utmost importance that where crimped terminations are used, the correct size of crimp and crimping tool are used. In addition, each cable conductor must have a minimum of 15 cm slack (service loop) left before its termination is fitted.

Cable identification

Cable identification codes corresponding to the cable number shown in the cable plan must be attached to each of the external cables. These identification codes should be positioned on the cable in such a way that they are readily visible after all panels have been fitted. In addition, each cable conductor should be marked with the terminal board number or socket to which it is connected.

Index

- 12 kHz transducers
 - Simrad 12-16/60, 149
 - 120 khz transducers
 - Simrad 120-25, 152
 - Simrad ES120-2,5x10, 157
 - Simrad ES120-4x10, 158
 - Simrad ES120-7, 156
 - Simrad ES120-7C, 156
 - Simrad ES120-7DD, 157
 - Simrad ES120-7F, 157
 - Simrad ES120-7G, 157
 - 12-16/60
 - transducer, 149
 - 12-16/60 transducer
 - connection, 72
 - 18 kHz transducers
 - Simrad 18-11, 150
 - Simrad ES18, 154
 - 200 kHz transducers
 - Simrad 200-28E, 153
 - Simrad 200-35F, 154
 - Simrad 200-7C, 153
 - Simrad 200-7F, 153
 - Simrad 200-7G, 153
 - Simrad ES200-7, 158
 - Simrad ES200-7C, 158
 - Simrad ES200-7CD, 159
 - Simrad ES333-7C, 159
 - 27 kHz transducers
 - Simrad 27-26/21, 150
 - 333 kHz transducers
 - Simrad ES333-7CD, 159
 - 38 kHz transducers
 - Simrad 38/200 Combi D, 151
 - Simrad 38/200 Combi W, 151
 - Simrad 38-7, 150
 - Simrad 38-9, 150
 - Simrad ES38-12, 155
 - Simrad ES38-10, 155
 - Simrad ES38B, 155
 - Simrad ES38DD, 155
 - 38/200 Combi C transducer
 - connection, 75
 - 50 kHz transducers
 - Simrad 50-18, 152
 - Simrad 50-18POR, 152
 - Simrad 50/200 Combi D, 152
 - Simrad 50-7, 151
 - 50/200 Combi C transducer
 - connection, 74
 - 70 khz transducers
 - Simrad ES70-11, 156
 - Simrad ES70-7C, 156
 - 710 kHz transducer
 - Simrad 710-36E, 154
- A**
- About
 - ES70, 10
 - NMEA telegram formats, 161
 - AC mains cable
 - 230 Vac, 48
 - Acoustic window, 144
 - example, 131
 - installation, 130
 - Air outlet
 - example, 123, 125
 - Annotations
 - telegram, 174
 - Anti-fouling
 - paint, 144
 - Approval
 - classification society, 15
 - Atlas
 - depth telegram, 175
 - ATS
 - telegram, 174
 - Attitude
 - heading, 168-169
 - heave, 168-169
 - pitch, 168-169
 - roll, 168-169
 - Auxiliary
 - connector, 99
- B**
- Battery GPT
 - cable, 59
 - Baudrate
 - NMEA 0183 standard, 85
 - BI500
 - interface, 86
 - Biomass
 - telegram, 172
 - Blister
 - Common guidelines, 125
 - installation, 121
 - physical location, 126
 - Bottom hardness
 - telegram, 172
 - Boundary water layer, 114
 - Bow thrusters
 - noise, 115
 - Box keel
 - example, 128
 - installation, 127
- C**
- Cable
 - 12-16/60 transducer, 72
 - 230 Vac, 48
 - 38/200 Combi C transducer, 75
 - 50/200 Combi C transducer, 74
 - battery GPT, 59
 - commercial power supply, 45
 - DC voltage to GPT, 59
 - deep water transducer, 73
 - dual beam transducer, 66
 - dual frequency transducer, 69
 - ES38-10 transducer, 70
 - ethernet, crossover, 50
 - ethernet, straight, 49
 - external trigger, 43, 58
 - GPT battery, 59
 - GPT on/off, 56
 - GPT synchronisation, 58
 - GPT trigger, 58
 - ITI serial line, 60
 - PI30 serial line, 62
 - PI32 serial line, 62
 - PI44 serial line, 61
 - PI54 serial line, 61
 - power supply, transceiver, 47
 - printer
 - parallel, 53
 - remote on/off, 56
 - requirements, 187
 - RS-232 three-wire, 41
 - serial line adapter, 55
 - ship's ground, 46
 - Single beam transducer, 64-65, 71
 - sonar serial line, 63
 - Split beam transducer, 67-68
 - Synchronisation, 58 transducer, splicing, 142
 - USB, 52
 - Cable gland
 - about, 138
 - GRP hull, 140
 - small hull, 141
 - steel hull, 139
 - wooden hull, 140
 - Cable glands
 - order numbers, 142
 - Cable list, 31
 - Cable plan
 - standard system, 27
 - Cable requirements
 - connections, 189

- grounding, 188
 - identification, 189
 - physical protection, 188
 - radio frequency
 - interference, 188
 - terminations, 189
 - trays, 187
 - Cable trays
 - requirements, 187
 - Cabling
 - drawings, 40
 - echo sounder
 - introduction, 26
 - Catch monitoring
 - interface, 88
 - Channel
 - disconnect, 81
 - Circuit board
 - handling, 184
 - packaging, 185
 - returning, 185
 - unpacking, 184
 - Clamping ring
 - blister, 121, 135
 - example, 123, 135
 - Clamping rings, 121, 127, 129–131
 - Classification society
 - approval, 15
 - Cleaning
 - transducer face, 143
 - Commercial power supply
 - cable, 45
 - Common guidelines
 - blister, 125
 - Communication
 - external devices, 84
 - NMEA 0183
 - parameters, 85
 - Compass deviation
 - responsibility, 15
 - Computer
 - installation, 24
 - Conduit
 - steel, 142
 - Configuration, 18
 - Connection
 - 12–16/60 transducer, 72
 - 38/200 Combi C
 - transducer, 75
 - 50/200 Combi C
 - transducer, 74
 - deep water transducer, 73
 - dual beam transducer, 66
 - dual frequency
 - transducer, 69
 - ES38–10 transducer, 70
 - single beam transducer,
 - 64–65, 71
 - split beam transducer, 67–68
 - Connections
 - GPT, 35
 - requirements, 189
 - Connector
 - Auxiliary, 99
 - identification, 35
 - Course data, ground
 - referenced
 - telegram, 166
 - Course data, water
 - referenced
 - telegram, 165
- D**
- Data bits
 - NMEA 0183 standard, 85
 - Datagrams, 85
 - DBS
 - telegram, 161, 170
 - DBT
 - telegram, 162
 - DC voltage to GPT
 - cable, 59
 - Deep water transducer
 - connection, 73
 - Depth
 - below surface
 - (telegram), 161
 - interface, 93
 - offset from transducer
 - (telegram), 162
 - telegram, 161–162
 - telegram (Atlas), 175
 - Depth below transducer
 - telegram, 162
 - Depth telegram
 - below transducer, 162
 - Diameter
 - steel conduit, 143
 - Distance travelled
 - telegram, 166
 - Docking plan
 - transducer location, 16
 - DPT
 - telegram, 162
 - Drawing
 - GPT
 - outline dimensions, 102
 - GPT Power supply
 - outline dimensions, 104
 - GPT Transducer plug, 107
 - Marine computer outline
 - dimensions, 106
 - Drawing file, 101
 - Drop keel
 - installation, 133
 - Dry docking
 - transducer location, 16
 - Dual beam transducer
 - 27-26/21, 150
 - connection, 66
 - Dual frequency single
 - beam transducer
 - 38/200 Combi D, 151
 - 38/200 Combi W, 151
 - 50/200 Combi D, 152
 - Dual frequency transducer
 - connection, 69
- E**
- Echo sounder
 - cable layout
 - introduction, 26
 - Echogram channel
 - how to disconnect, 81
 - how to install, 81
 - EK500 Depth
 - telegram, 167
 - EK60
 - cable layout
 - introduction, 26
 - Electro-static discharge, 185
 - EM Attitude
 - telegram, 168–169
 - EMC interference, 142
 - Emuge, 145
 - Equipment
 - handling, 177
 - inspection, 179
 - lifting, 177
 - re-packaging, 183
 - receipt, 15
 - responsibility, 14
 - storage after unpacking, 181
 - storage after use, 181
 - storage before use, 178
 - transportation, 177
 - unpacking, 179
 - ES38–10 Transducer
 - connection, 70
 - ESD protection, 185
 - ESD, what is it?, 185
 - Ethernet
 - crossover cable, 50
 - straight cable, 49
 - Example
 - Acoustic window, 131
 - Air outlet, 123, 125
 - box keel, 128
 - Clamping ring, 123, 135
 - flush mounting, 130

- Inside the hull, 132
- Mounting ring, 123, 125, 135
- Streamlined blister, 123, 125

Export

- data, 84

External mount

- installation, 118

External mounting

- flat hull, 121
- polyester hull, 120
- steel hull, 119
- wooden hull, 120

External trigger

- cable, 58
- cable specifications, 43
- interface, 95
- master system, 96
- slave system, 97

F

Flat hull

- external mounting, 121

Flush mounting

- example, 130
- steel tanl, 128

Format specifications, 160

Frequency channel

- installation, 81

G

General

- supply conditions, 14

General Purpose

Transceiver

- installation, 22
- interface, 79
- transducer plug, 107

Geographical position

- telegram, 163

GGA

- telegram, 163

Glass-reinforced plastic

hull

- cable gland, 140

GLL

- telegram, 163

Global positioning

- telegram, 163

Global Positioning System

- interface, 90

GPS

- interface, 90

GPT

- Auxiliary connector, 99
- connections, 35
- installation, 22
- interface, 79

- outline dimensions, 102
- power supply, 47

GPT battery

- cable, 59

GPT Connection

- 12–16/60 transducer, 72

- 38/200 Combi C

- transducer, 75

- 50/200 Combi C

- transducer, 74

- deep water transducer, 73

- dual beam transducer, 66

- Dual frequency

- transducer, 69

- ES38–10 transducer, 70

- single beam transducer,

- 64–65, 71

- split beam transducer, 67–68

GPT on/off

- cable, 56

GPT Power supply

- outline dimensions, 104

GPT synchronisation

- cable, 58

GPT Transducer plug

- drawing, 107

GPT trigger

- cable, 58

Grounding

- requirements, 188

GRP hull

- cable gland, 140

H

Handling

- circuit boards, 184

Handling rules

- transducer, 143

HDG

- telegram, 164

HDM

- telegram, 164

HDT

- telegram, 165

Heading

- attitude telegram, 168–169

- telegram, 164

Heading deviation and

- variation

- telegram, 164

Heading magnetic

- telegram, 164

Heading, true

- telegram, 165

Heat, excessive

- do NOT expose
- transducer, 143

Heave

- attitude telegram, 168–169

Heave roll and pict

- protocol, 173

Heave sensor

- interface, 92, 94

Hempel IFA Coatings, 145

HFB

- telegram, 170

How to

- deal with ESD, 185

- disconnect channel, 81

- install frequency

- channel, 81

- pack a circuit board, 185

- return a circuit board, 185

- unpack a circuit board, 184

- unpack a circuit board

- on board, 185

Hull unit

- installation, 134

I

Identification

- cable requirements, 189

- connectors, 35

IEC plug, 48

Import

- data, 84

Important

- if something breaks

- down, 11

- information, 10

- switching off the echo

- sounder, 11

- when docking, 10

- when the echo sounder

- is not used, 10

Inclination

- angle, 116

Information

- NMEA 0183, 85

Inside the hull

- example, 132

- installation, 131

Inspection

- equipment, 179

Installation, 17

- drawings, 101

- GPT, 22

- Marine Computer, 24

- requirements, 15

Installation method

- Acoustic window, 130

- Blister, 121

- Box keel, 127

- Drop keel, 133

- Flush mounting, 128
 - Hull unit, 134
 - Inside the hull, 131
 - Retractable, 134
 - Steel tank, 128
 - Towed body, 134
 - Integration, 84
 - Interface
 - external, 84
 - Interface setup
 - ITI, 87
 - Interface specifications, 160
 - Interfaces
 - BI500, 86
 - catch monitoring systems, 88
 - depth output, 93
 - external trigger, 95
 - General Purpose Transceiver, 79
 - Global Positioning System, 90
 - GPS, 90
 - GPT, 79
 - heave sensor, 92, 94
 - navigation system, 90
 - PI Family, 88
 - sonar systems, 90
 - transceiver, 79
 - International Marine Coatings, 145
 - Introduction, 9
 - ITI
 - interface setup, 87
 - serial line communication, 60
 - ITI telegrams
 - enable, 88
- J**
- Jotun, 144
- L**
- Lifting
 - equipment, 177
 - transducer, 143
 - List of cables, 31
 - Location
 - recommendation, 116
 - transducer, 113
- M**
- Mains cable
 - 230 Vac, 48
 - Maintenance rules
 - transducer, 144
- Marine computer**
- outline dimensions
 - drawing, 106
- Marine Computer**
- installation, 24
- Marine computer outline dimensions**
- drawing, 106
- Master system, 96**
- Mounting ring**
- blister, 121, 135
 - example, 123, 125, 135
- Mounting rings, 121, 127, 129–131**
- N**
- National Marine Electronics Association, 85**
- Navigation system**
- interface, 90
- NMEA**
- about formats, 161
 - telegram specifications, 160
- NMEA 0183**
- communication parameters, 85
 - information, 85
- NMEA telegram**
- DBT, 162
 - GGA, 163
 - GLL, 163
 - HDG, 164
 - HDM, 164
 - HDT, 165
 - RMC, 165
 - VHW, 165
 - VLW, 166
 - VTG, 166
- Noise**
- boundary water layers, 114
 - bow thrusters, 115
 - propeller, 115
 - protruding objects, 114
- Noise sources**
- inspection, 16
- O**
- Order numbers**
- cable glands, 142
- Outline dimensions**
- GPT, 102
 - GPT Power supply, 104
- P**
- Packaging**
- circuit boards, 185
- Paint**
- anti-fouling, 144
- Painting**
- transducer face, 143
- Parity bit**
- NMEA 0183 standard, 85
- Physical cable protection requirements, 188**
- Physical location**
- blister, 126
- PI**
- interface, 88
- PI sensor definition telegram, 171**
- PI telegrams**
- enable, 89
- PI30**
- interface, 88
 - serial line communication, 62
- PI32**
- interface, 88
 - serial line communication, 62
- PI44**
- interface, 88
 - serial line communication, 61
- PI54**
- interface, 88
 - serial line communication, 61
- Pitch**
- attitude telegram, 168–169
- Plug sockets**
- GPT, 35
- Polyester hull**
- external mounting, 120
- Position geographical telegram, 163**
- Position GNNS telegram, 165**
- Position system fixed data telegram, 163**
- Power supply**
- cable, 45
- Printer**
- cable
 - parallel, 53
- Procedure**
- channel disconnect, 81
 - channel installation, 81
 - echogram channel disconnect, 81
 - echogram channel installation, 81
 - frequency channel installation, 81

- Propeller
 - noise, 115
- Proprietary
 - telegram specifications, 167, 174
- Protection
 - against ESD, 185
 - temperature, 183
- Protruding objects, 114
- PSIMDHB
 - telegram, 172
- PSIMP-D
 - telegram, 171
- Purpose, this manual, 9

- R**
- Radio Frequency
 - interference requirements, 188
- Re-packaging
 - equipment, 183
- Receipt
 - equipment, 15
- Remote on/off
 - cable, 56
- Requirements
 - cables, 187
 - for installation, 15
- Responsibility
 - compass deviation, 15
 - equipment, 14
- Retractable
 - installation, 134
- Returning
 - a circuit board, 185
- RJ45
 - plug, 49–50
- RMC
 - telegram, 165
- Roll
 - attitude telegram, 168–169
- RS-232
 - cable specifications, 41
 - serial line adapter, 55
- Rules
 - safety, 176

- S**
- Safety
 - general rules, 176
- Self-locking taps, 145
- Serial line
 - adapter, 55
 - ITI, 60
 - PI30, 62
 - PI32, 62
 - PI44, 61
 - PI54, 61
 - sonar, 63
- Serial line adapter
 - cable, 55
- SH40
 - interface, 90
- SH80
 - interface, 90
- SH90
 - interface, 90
- Shielding
 - steel conduit, 143
- Ship's ground
 - cable, 46
- Simrad ITI
 - interface setup, 87
- Simrad PI30
 - interface, 88
- Simrad PI32
 - interface, 88
- Simrad PI44
 - interface, 88
- Simrad PI54
 - interface, 88
- Simrad SH40
 - interface, 90
- Simrad SH80
 - interface, 90
- Simrad SH90
 - interface, 90
- Simrad sonars
 - interface, 90
- Simrad SP60
 - interface, 90
- Simrad SP70
 - interface, 90
- Simrad SP90
 - interface, 90
- Simrad SX90
 - interface, 90
- Single beam transducer
 - 120-25, 152
 - 18-11, 150
 - 200-28E, 153
 - 200-35, 154
 - 200-7C, 153
 - 200-7F, 153
 - 200-7G, 153
 - 38-7, 150
 - 38-9, 150
 - 50-18, 152
 - 50-18POR, 152
 - 50-7, 151
 - 710-36E, 154
 - connection, 64–65, 71
- Single or dual beam
 - transducer
 - 12-16/60, 149
- Slave system, 97
- Smooth surface, 118, 122, 127, 129–130, 132, 135
- Sockets
 - GPT, 35
- Sonar
 - serial line communication, 63
- Sonar system
 - interface, 90
- Sounder/TSS1
 - telegram, 173
- SP60
 - interface, 90
- SP70
 - interface, 90
- SP90
 - interface, 90
- Specification
 - data formats, 160
 - interface formats, 160
 - telegram formats, 160
- Specifications
 - technical, 108
- Speed data, ground
 - referenced telegram, 166
- Speed data, water
 - referenced telegram, 165
- Splicing
 - transducer cable, 142
- Split beam transducer
 - connection, 67–68
 - ES120-2,5x10, 157
 - ES120-4x10, 158
 - ES120-7, 156
 - ES120-7C, 156
 - ES120-7DD, 157
 - ES120-7F, 157
 - ES120-7G, 157
 - ES18, 154
 - ES200-7, 158
 - ES200-7C, 158
 - ES200-7CD, 159
 - ES333-7C, 159
 - ES333-7CD, 159
 - ES38-12, 155
 - ES38-10, 155
 - ES38B, 155
 - ES38DD, 155
 - ES70-11, 156
 - ES70-7C, 156
- Standard
 - NMEA 0183 standard, 85
- Steel conduit
 - diameter, 143
 - qualities, 143

- shielding, 143
 - why, 142
 - Steel hull
 - cable gland, 139
 - external mounting, 119
 - Steel tank
 - flush mounting, 128
 - water filled, 129
 - Stop bit
 - NMEA 0183 standard, 85
 - Storage
 - equipment (after unpacking), 181
 - equipment (after use), 181
 - equipment (before use), 178
 - Streamlined blister
 - example, 123, 125
 - Streamlined transducer
 - flat hull, 121
 - polyester hull, 120
 - steel hull, 119
 - wooden hull, 120
 - Sunlight
 - do NOT expose transducer, 143
 - Supply
 - conditions, 14
 - Supply power
 - tolerance, 15
 - Support bar, 122, 128–129
 - Surface
 - blister, 135
 - smooth, 118, 122, 127, 129–130, 132
 - SX90
 - interface, 90
 - Synchronisation
 - cable, 58
 - master system, 96
 - slave system, 97
 - transmit, 95
- T**
- Taps, self-locking, 145
 - Technical specifications, 108
 - Telegram
 - biomass, 172
 - bottom hardness, 172
 - Course over ground and Ground speed, 166
 - DBT, 162
 - Depth below transducer, 162
 - Dual ground/water distance, 166
 - Geographical position latitude/longitude, 163
 - GGA, 163
 - GLL, 163
 - Global positioning system fix data, 163
 - HDG, 164
 - HDM, 164
 - HDT, 165
 - Heading, deviation and variation, 164
 - Heading, magnetic, 164
 - Heading, true, 165
 - HFB, 170
 - PI sensor definition, 171
 - PSIMDHB, 172
 - PSIMP-D, 171
 - Recommended minimum specific GNSS data, 165
 - RMC, 165
 - Trawl headrope to footrope and bottom, 170
 - VHW, 165
 - VLW, 166
 - VTG, 166
 - Water speed and heading, 165
 - Telegram code
 - ATS, 174
 - DBS, 161, 170
 - DPT, 162
 - EK500 Depth, 167
 - EM Attitude 1000, 168
 - EM Attitude 3000, 169
 - Sounder/TSS1, 173
 - Telegram format specifications, 160
 - Telegram formats
 - about NMEA, 161
 - Telegram name
 - Annotations, 174
 - Depth, 162
 - Depth below surface, 161
 - Depth of trawl below surface, 170
 - EK500 Depth, 167
 - Kongsberg EM Attitude 1000, 168
 - Kongsberg EM Attitude 3000, 169
 - Simrad Sounder/TSS1, 173
 - Telegram specifications
 - NMEA, 160
 - proprietary, 167, 174
 - Telegrams, 85
 - Temperature
 - protection, 183
 - Terminations
 - requirements, 189
 - Toe-in, 118, 126
 - Tolerance
 - supply power, 15
 - Towed body
 - installation, 134
 - Transceiver
 - connection, 79
 - interface, 79
 - power supply, 47
 - Transducer
 - docking plan, 16
 - handling, 143
 - installation, 113
 - lifting, 143
 - location, 113
 - maintenance, 144
 - recommended location, 116
 - Transducer 120-25, 152
 - Transducer 12–16/60, 149
 - Transducer 18–11, 150
 - Transducer 200-28E, 153
 - Transducer 200-35, 154
 - Transducer 200-7C, 153
 - Transducer 200-7F, 153
 - Transducer 200-7G, 153
 - Transducer 27-26/21, 150
 - Transducer 38/200 Combi D, 151
 - Transducer 38/200 Combi W, 151
 - Transducer 38-7, 150
 - Transducer 38-9, 150
 - Transducer 50-18, 152
 - Transducer 50-18POR, 152
 - Transducer 50/200 Combi D, 152
 - Transducer 50-7, 151
 - Transducer 710-36E, 154
 - Transducer cable
 - 12–16/60 transducer, 72
 - dual beam transducer, 66
 - ES38–10, 70
 - single beam transducer, 64–65, 71
 - splicing, 142
 - Transducer ES120-2,5x10, 157
 - Transducer ES120-4x10, 158
 - Transducer ES120-7, 156
 - Transducer ES120-7C, 156
 - Transducer ES120-7DD, 157
 - Transducer ES120-7F, 157
 - Transducer ES120-7G, 157
 - Transducer ES18, 154
 - Transducer ES200-7, 158
 - Transducer ES200-7C, 158
 - Transducer ES200-7CD, 159
 - Transducer ES333-7C, 159
 - Transducer ES333-7CD, 159
 - Transducer ES38-12, 155

- Transducer ES38–10, 155
- Transducer ES38B, 155
- Transducer ES38DD, 155
- Transducer ES70-11, 156
- Transducer ES70-7C, 156
- Transducer face
 - cleaning, 143
 - painting, 143
- Transducer plug
 - drawing, 107
- Transmit synchronisation, 95
- Transport protection, 143
- Transportation
 - equipment, 177
- Travelled distance
 - telegram, 166
- Trawl
 - depth
 - telegram, 170
- Trawl, bottom
 - telegram, 170
- Trawl, footrope
 - telegram, 170
- Trawl, headrope
 - telegram, 170
- Trigger
 - external, 95
 - master system, 96
 - slave system, 97
- TrigIn, 97
- TrigOut, 96

U

- Uninterruptable Power
 - Supply, 15
- Unpacking
 - circuit boards, 184
 - equipment, 179
- USB
 - cable, 52

V

- VHW
 - telegram, 165
- VLW
 - telegram, 166
- VTG
 - telegram, 166

W

- Water filled
 - steel tank, 129
- Wiring
 - general requirements, 16
- Wooden hull

ISBN-13: 978-82-8066-117-3

©2010 Kongsberg Maritime AS

**Simrad ES70 Fish finding echo sounder
Installation manual**

**Simrad ES70 Fish finding echo sounder
Installation manual**

**Simrad ES70 Fish finding echo sounder
Installation manual**