

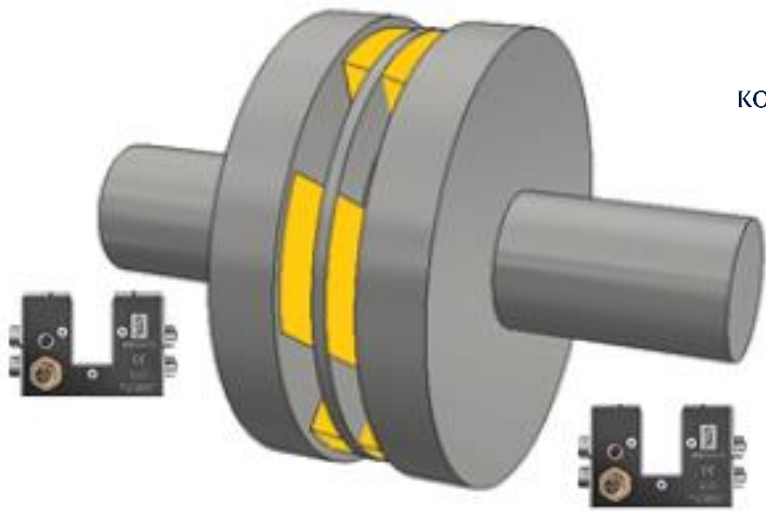

KONGSBERG



SAFE OPERATION & CONDITION MONITORING OF FLEXIBLE COUPLINGS

## MetaPower Flex for shaft couplings in drivetrains

Avoid downtime. Save time on maintenance. Use the well proven MetaPower technology for real time analysis and trending of drivetrains and couplings.

KONGSBERG MetaPower consists of high precision optical sensors, capable of measuring relative twist angles between 2 points on the drivetrain, with a resolution of  $0.0001^\circ$  at high RPM. Combined with the HSIO processing module, you get a powerful tool for monitoring flexible couplings.

### Real-time analysis, and long-term logging

The software platform allows you to see a real-time picture of the twist + amplitude of twist oscillations (Torsional vibration). You can set warning limits of high levels. This will alert if a coupling is overstressed or critically worn out. An automatic slow down signal can be commanded on digital soft switch.

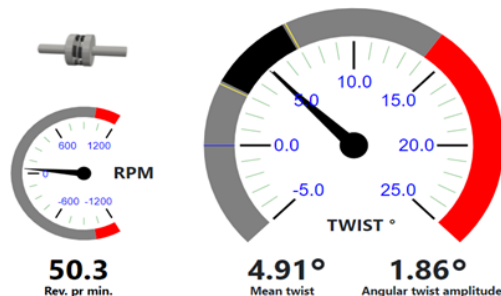

Gauge vision of twist and RPM of the coupling. The colored area(black) visualizes the current amplitude of twist oscillations.

# METAPOWER FLEX

### TECHNICAL DATA

- Twist meter with additional features
- Provides safe operation of flexible couplings
- Provides real-time analysis of torsion-pattern
- Well known KONGSBERG sensing and automation technology
- No software installation
- Easy access through web interface
- RS-485 or TCP-IP Modbus interface for data-transfer to main monitoring systems
- 2x digital output switch for external alarm
- Basic trend-tools to track twist development
- Data stored locally on HSIO module in SQL format with history for minimum 10 years
- Limited maintenance, clean only

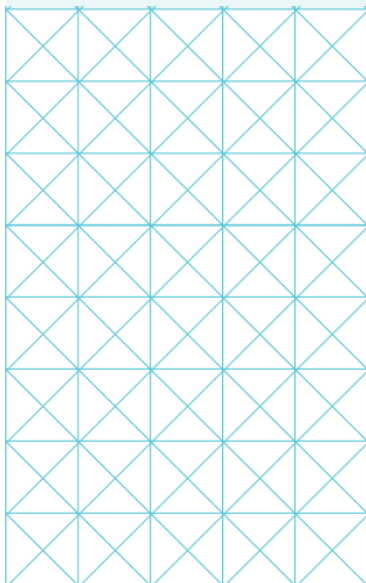
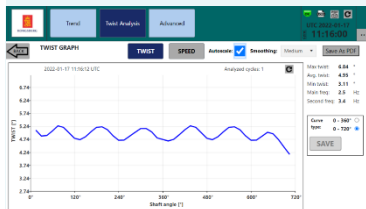

## Safe operation, documented

Manufacturers of flexible couplings typically recommend visual inspections of coupling de-settlement over time. (Twist that does not revert to original condition when unloaded) Monitoring the twist digitally contributes to safe operation, also between inspections, and logs events like e.g. overloading. Rubber gets hard over time, and manufacturers typically specify a replacement interval. This system provides information about development of actual condition over time. This can be valuable when considering the replacement intervals.

## Closely monitor drive train performance with live analysis

With the graphical tools available, you can also analyze the behavior of the coupling in real time. This information can be used to discover & analyze unwanted vibration patterns in the drivetrain.

In the example picture, the system is installed to a 6 cyl. 4 stroke engine. The twist of the coupling clearly reflects the ignition pulses in a 0-720° revolution view.

## Engineering & Turn-key

KM can offer expertise and engineering solutions for different type of couplings.

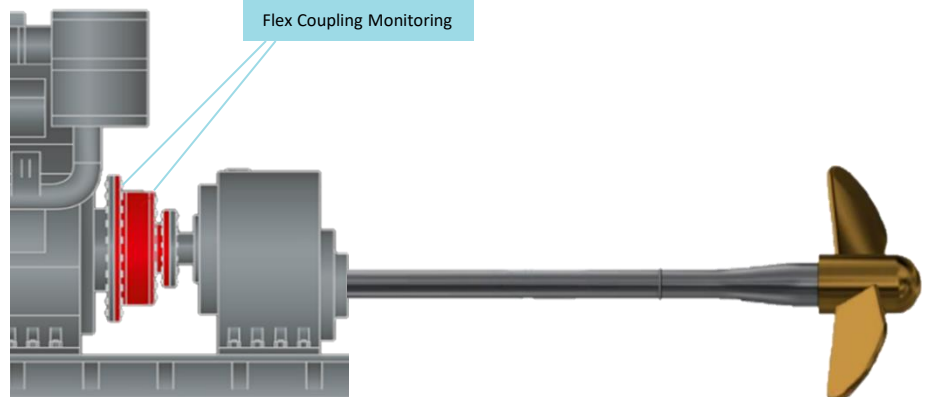
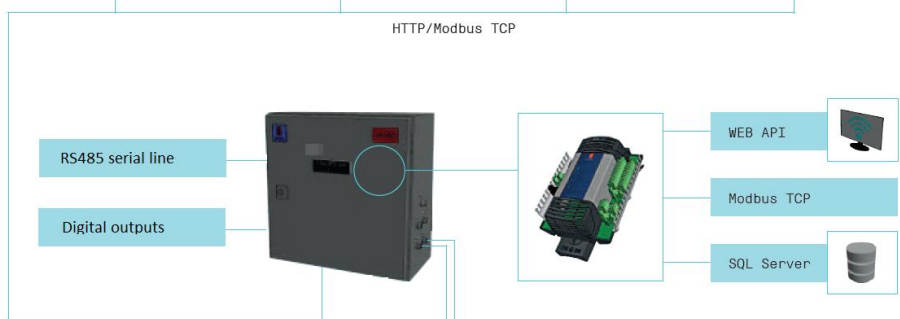

Kongsberg Maritime  
P.O.Box 483,  
NO-3601 Kongsberg,  
Norway

Switchboard: +47 815 73 700  
Global support 24/7: +47 33 03 24 07  
E-mail sales: [km.sales@km.kongsberg.com](mailto:km.sales@km.kongsberg.com)